



Since January 2020 Elsevier has created a COVID-19 resource centre with free information in English and Mandarin on the novel coronavirus COVID-19. The COVID-19 resource centre is hosted on Elsevier Connect, the company's public news and information website.

Elsevier hereby grants permission to make all its COVID-19-related research that is available on the COVID-19 resource centre - including this research content - immediately available in PubMed Central and other publicly funded repositories, such as the WHO COVID database with rights for unrestricted research re-use and analyses in any form or by any means with acknowledgement of the original source. These permissions are granted for free by Elsevier for as long as the COVID-19 resource centre remains active.



ELSEVIER

Contents lists available at ScienceDirect

Clinical Nutrition

journal homepage: <http://www.elsevier.com/locate/clnu>

Original article

Plasma citrulline correlates with basolateral amino acid transporter LAT4 expression in human small intestine

Stefano Maric^{a,1}, Pascal Flüchter^{b,1}, Laura Chiara Guglielmetti^c, Ralph Fabian Staerke^d, Tom Sasse^e, Tanja Restin^{b,f}, Christoph Schneider^b, Stefan Gerhard Holland-Cunz^g, Pascal Crenn^h, Raphael Nicolas Vuille-dit-Bille^{b,g,*}

^a University of Basel, School of Medicine, Basel, Switzerland

^b Institute of Physiology, University of Zurich, Switzerland

^c Department of Visceral and Thoracic Surgery, Cantonal Hospital of Winterthur, Switzerland

^d Clarunis, University Center for Gastrointestinal and Liver Diseases, Basel, Switzerland

^e Department of Cardiology, University Hospital of Zurich, Switzerland

^f Newborn Research Zurich, Department of Neonatology, University Hospital Zurich and University of Zurich, Zurich, Switzerland

^g Department of Pediatric Surgery, University Children's Hospital of Basel, Switzerland

^h Hepato-gastroenterology and Nutrition, Hôpital Ambroise Paré, APHP-Université Paris Saclay, Boulogne Billancourt, France

ARTICLE INFO

Article history:

Received 16 May 2020

Accepted 1 October 2020

Keywords:

LAT4

Citrulline

Enterocyte mass

Arginine

Transport

SUMMARY

Background & aims: Plasma citrulline, a non-protein amino acid, is a biochemical marker of small intestine enterocyte mass in humans. Indeed, citrulline is highly correlated with residual bowel length in patients with short bowel syndrome. It is known to be synthesised in epithelial cells of the small intestine from other amino acids (precursors). Citrulline is then released into systemic circulation and interconverted into arginine in kidneys. If plasma citrulline concentration depends on abundance of intestinal amino acid transporters is not known. The aim of the present study was to explore whether plasma citrulline concentration correlates with the expression of intestinal amino acid transporters. Furthermore, we assessed if arginine in urine correlates with plasma citrulline.

Methods: Duodenal samples, blood plasma and urine were collected from 43 subjects undergoing routine gastroduodenoscopy. mRNA expression of seven basolateral membrane amino acid transporters/transporter subunits were assessed by real-time PCR. Plasma and urine amino acid concentrations of citrulline, its precursors and other amino acids were analysed using High Performance Liquid Chromatography measurements. Amino acid transporter mRNA expression was correlated with blood plasma and urine levels of citrulline and its precursors using Spearman's rank correlation. Likewise, urine arginine was correlated with plasma citrulline.

Results: Plasma citrulline correlated with the mRNA expression of basolateral amino acid transporter LAT4 (Spearman's $r = 0.467$, $p = 0.028$) in small intestine. None of the other basolateral membrane transporters/transporter subunits assessed correlated with plasma citrulline. Plasma citrulline correlated with urinary arginine, (Spearman's $r = 0.419$, $p = 0.017$), but not with urinary citrulline or other proteinogenic amino acids in the urine.

Conclusions: In this study, we showed for the first time that small intestinal basolateral LAT4 expression correlates with plasma citrulline concentration. This finding indicates that LAT4 has an important function in mediating citrulline efflux from enterocytes. Furthermore, urine arginine correlated with plasma citrulline, indicating arginine in the urine as possible additional marker for small intestine enterocyte mass. Finally, basolateral LAT4 expression along the human small intestine was shown for the first time.

© 2020 Elsevier Ltd and European Society for Clinical Nutrition and Metabolism. All rights reserved.

* Corresponding author. Department of Pediatric Surgery, University Children's Hospital of Basel, Spitalstrasse 33, 4056, Basel, Switzerland.

E-mail address: rnuuille@gmail.com (R.N. Vuille-dit-Bille).

¹ Equal contribution.

1. Introduction

The epithelium of the human small intestine forms a continuous layer of cells organized into villi protruding into the lumen of the gut. This epithelium reflects the fastest regenerating tissue within the human body, completely renewing within 5 days [1]. Among the different cell types forming the intestinal epithelium, enterocytes reflect the most numerous. Small intestinal enterocytes are polarized cells with the apical membrane (brush-border membrane; BBM) facing the lumen of the gut and the basolateral membrane, which is in contact with neighboring cells [2,3]. Dietary proteins are hydrolysed into small peptides by stomach and pancreas proteases and finally by brush-border membrane-bound peptidases into absorbable units [4], namely tri-, dipeptides and amino acids (AAs) [2,5,6]. These units are transported across the BBM by various different AA transporters and via the peptide transporter PEPT1 [2,5,7]. In contrast, only single amino acids can be transported across the basolateral membrane and released into the extracellular space, which is performed by a different set of amino acid transporters. Several of these basolateral AA transporters have been identified and characterized in the past, including LAT4 (SLC43A2) [8]. To enable net efflux of all different AAs from small intestinal enterocytes, a functional interaction between different types of basolateral AA transporters is needed. LAT4 belongs to the sodium-independent large neutral AA transporter family 'system L' and is expressed in the basolateral membrane of small intestinal enterocytes (as well as of proximal tubule kidney cells) [8,9]. LAT4 acts as low affinity-facilitated protein enabling diffusion of branched-chain AAs (leucine, isoleucine, valine) [10], as well as phenylalanine and methionine [8]. Hereby LAT4 not only mediates net AA efflux from enterocytes, but also provides substrates for amino acid exchange provided by other basolateral transporters, such as y^+ LAT1-4F2 (SLC7A7-SLC3A2) or LAT2-4F2 (SLCSLC7A8-SLC3A2) [8].

The importance of intestinal nutrient absorption becomes evident in situations of intestinal failure, which reflects the reduction of functional intestinal tissue below the minimum amount that is necessary for digestion and absorption to maintain growth in children and/or homeostasis in adults. The lack of minimally invasive methods for the quantitative assessment of this functional bowel length remains an obstacle in gastroenterology. Short bowel syndrome describes a reduction in functional bowel length and it is the most common etiology of intestinal failure in children [11,12] and adults [13]. Several diseases of the gastrointestinal tract including malrotation with volvulus, necrotizing enterocolitis, small intestinal atresia, Hirschsprung's disease can demand excessive intestinal resections ending in short bowel syndrome and intestinal failure [14]. Patients are mostly dependent on long-term parenteral nutrition, which causes significant morbidity and mortality.

The non-proteinogenic, neutral α -amino acid citrulline is synthesized predominantly in the small intestine and its plasma concentration has been shown to correlate with functional small bowel enterocyte mass [15,16]. Citrulline content in diet/food is generally considered to be absent or very low, and known sources are found among members of the taxa of Cucurbitaceae, including the watermelon (*Citrullus lanatus*) [15–17]. Hence, plasma citrulline, which is reduced in patients with short-bowel syndrome or extensive enteropathies, is now considered as a biomarker of residual functional enterocyte mass [18]. In the small intestines citrulline is mainly *de novo* synthesized from precursor amino acids deriving from nutrition or systemic circulation [19,20], including glutamine, arginine, proline, glutamate and ornithine [17,19,21–26]. Citrulline

is converted to arginine in kidney proximal tubules by Argininosuccinate synthetase and Argininosuccinate lyase [17]. Arginine acts among other functions as component of proteins and NO° precursor in different tissues before being excreted in the urine.

The primary aim of the present study was to explore whether plasma citrulline concentration correlates with expression of particular basolateral amino acid transporters in the small intestine. Such correlation could provide insights into the nature of transporters that are involved in the release of citrulline into systemic circulation.

The second aim was to assess a possible correlation between plasma citrulline and urinary amino acids in order to find a less invasive marker for functional small bowel mass.

2. Materials and methods

2.1. Study population

Forty-three subjects (19 males and 24 females) were included in the present study. Subjects were examined at the University Hospital of Zürich, Switzerland and underwent gastroduodenoscopy as part of a routine medical check-up. Thereby, small mucosal biopsies were taken from duodenum parts II (descending) and III (inferior/horizontal). Blood plasma and urine amino acid levels were assessed using UPLC (Ultraperformance Liquid Chromatography) measurement. Sampling of intestinal biopsies, blood and urine were done after overnight fasting. Physiologic parameters including body mass index (BMI), mean arterial blood pressure and heart rate were assessed in all subjects, as well as co-morbidities, medications and blood parameters including glucose, creatinine and urea. Plasma protein and albumin levels were measured in 6/43 subjects and were only assessed when considered clinically relevant.

2.2. Inclusion criteria

Inclusion criteria consisted of routine medical check-up, age between 18 and 80 years.

2.3. Exclusion criteria

Exclusion criteria consisted of pathologies of the gastrointestinal tract (including inflammatory bowel disease and coeliac disease, unintended weight loss, cancers, renal- or hepatic failure (including portal hypertension), bleeding disorders and/or oral anticoagulation, infectious disease, pregnancy, drug or alcohol abuse, mental retardation, or refusal to participate.

2.4. Ethics

The study was approved by the local ethics committee in Zürich (reference number: EK-1744), and written informed consent was obtained from all included subjects.

2.5. Sample preparation for UPLC analysis

Plasma (50 μl) was deproteinized with an equal volume of 10% sulfosalicylic acid containing the internal standard Norvaline at a final concentration of 250 $\mu\text{mol/l}$. Samples were centrifuged at 12,000 g for 5 min and 20 μl of the supernatant was derivatized according to the manufacturer's instructions. Derivatized products were transferred to a vial for analysis.

2.6. UPLC analysis

UPLC analysis was carried out using an Acquity™ UPLC system with an integrated ACQUITY-UPLC-Tunable-UV detector and the MassTrak™ AAA Solutions Kit (Waters Corporation, Milford, MA, USA) using pre-column derivatization of amino acids with a 6-aminoquinolyl-N-hydroxysuccinimidyl carbamate tag (AccQTag®) followed by reversed-phase UPLC on a C18 column (1.7 µm; 2.1 × 150 mm) and UV detection at 260 nm. Derivatized samples (1 µL injection) were separated on a column maintained at 43 °C. The amino acid calibration standard kit was purchased from the Sigma Chemical Company (St. Louis, MO, USA). The mobile phase consisted of 2 buffers. Buffer A: 8–10% acetonitrile; 4–6% formic acid; 84–88% ammonium acetate/water and Buffer B: >95% acetonitrile; 5% acetic acid. After injection, a stepped gradient at a flow rate of 0.4 mL/min was applied (total run time: 45 min). Data were analyzed using the Empower™ 2 software (Waters Corporation, Milford, MA, USA).

2.7. RNA extraction and real-time polymerase chain reaction (PCR)

After removal, tissue samples were put into 1.5 mL Eppendorf tubes (3810X, Eppendorf, Germany), frozen in liquid nitrogen, and stored at –80 °C. The RNeasy Mini Kit (Qiagen, The Netherlands) was used for RNA extraction. Frozen tissue was homogenized with MagNa Lyser Green Beads (Roche, Switzerland) for 1 min (2 × 30", 6000 revolutions/min). RNA quantity and quality were assessed using a ND-1000 NanoDrop UV- spectrophotometer (NanoDrop Technologies, USA) and an Agilent 2100 Bioanalyzer (NanoChip, Agilent Technologies, USA), respectively. Reverse transcription was performed with total RNA (8 ng/µL reaction) as template using the TaqMan Reverse Transcription Kit (Applied Biosystems, USA). Quantitative PCR was performed using 8 ng cDNA as template. qPCR reactions were carried out in duplicates using the Taq-Man Reverse Transcription Kit (Applied Biosystems, USA) in a Prism 7700 cyclor (Applied Biosystems, USA). Target messenger RNA abundance was calculated relative to the housekeeping gene Villin [27] and expressed as relative expression $R = 2^{[Ct(\text{housekeeping gene}) - Ct(\text{target gene})]}$, with Ct being the cycle number observed at the threshold. In order to verify our findings not being biased by the chosen housekeeping gene (Villin), target and Villin mRNA were additionally calculated relative to the gene encoding hypoxanthine guanine phosphoribosyltransferase (HPRT) [28].

Primers and probes were used as previously described [5]. The fluorescent reporter dye FAM and the quencher dye TAMRA were used to label the probes at the 5' and 3' end, respectively (Microsynth AG, Switzerland). 18S (Applied Biosystems, USA) was labeled with VIC as fluorescent reporter dye at the 5' end and the quencher dye TAMRA at the 3' end.

2.8. Tissue harvest and storage

Biopsies taken during upper and lower endoscopies were frozen in liquid nitrogen and stored at –80 °C until further processing. Tissues were embedded in OCT embedding matrix (Cell Path, Newton, Wales, United Kingdom). A cryotome, (Leica CM 1850 Cryostat, Switzerland) was used to produce 5 µm sections that were immediately transferred onto Polylysine Menzel slides (Gerhard Menzel GmbH, Braunschweig, Germany). The slides were stored at –20 °C until later processing.

2.9. Immunofluorescence

After defreezing in a wet chamber for 5 min at room temperature, sections were fixed in cold (–20 °C) methanol for 90 s. After

fixation, slides were washed 3 × 5 minutes in PBS (phosphate buffered saline; 137.0 mM NaCl, 2.7 mM KCl, 12.0 mM HPO₄²⁻/H₂PO₄). Tissues were blocked with 2% BSA, 5% Donkey Serum and 0.04% Triton X-100 in PBS for 1 h at room temperature. Primary antibodies were diluted 1:1000 (LAT4) and 1:250 (ACE2) in blocking solution and tissues were incubated for 1 h at room temperature. Affinity-purified polyclonal rabbit anti-human/mouse LAT4 (from Pineda, Berlin, Germany) and monoclonal mouse anti-human ACE2 (from R&D Systems, Minneapolis, MN) were used as primary antibodies. After incubation, tissue specimens were rinsed again (3 × 5 minutes in PBS) and incubated with secondary antibodies for 1 h protected from the light at room temperature. Alexa Fluor 488 donkey anti-mouse IgG (1:500) and Alexa Fluor 647 donkey anti-rabbit IgG (1:500) diluted in 2% BSA in PBS were used as secondary antibodies. After washing again (3 × 5 minutes in PBS) specimens were incubated with 4', 6'-diamidino-2-phenyl-indole (DAPI, Merck, NJ; 0.5 µg/ml) for 5 min at room temperature. Tissue specimens were washed again (1 × 5 minutes in PBS) and mounted using Vectashield Antifade Mounting Medium (Vecta Laboratories, Burlingame, California, United States). Fluorescence was detected with a Leica fluorescence microscope (Leica CTR600; Leica Camera AG, Wetzlar, Germany). Leica AF lite and ImageJ freeware softwares were used to acquire and process the images.

2.10. Statistics

Graphical assessment and the application of the Shapiro–Wilk test revealed a non-normal distribution of our data, and presence of outliers was confirmed, as expected due to the small sample size. Therefore Spearman rank correlation coefficients were calculated to examine the relation between the mRNA expression of amino acid transporters in the duodenum and blood plasma levels of the amino acid citrulline and its precursors, as well as between blood plasma and urine amino acid concentrations. P-values of 0.05 or less were considered as statistically significant.

3. Results

3.1. Baseline demographics of subjects

Forty-three subjects were included in the present study. Among them 19 (44%) were males and 24 (56%) were females. Median age was 60 years, ranging from 22 to 77 years. Median BMI was 26.6 kg/m², ranging from 17.1 to 36.5 kg/m². Median plasma creatinine was 72.5 µmol/l (IQR 63.5–82.0 µmol/l). Median aspartate transaminase (AST) was 27.5 U/l (IQR 23.0–33.5 U/l) and median alanine transaminase (ALT) was 25.5 U/l (IQR 22.8–36.8 U/l). Plasma protein (median 74.0 g/L; IQR 71.5–77.3 g/L) and albumin (median: 43.0 g/L; IQR 42.0–45.8 g/L) levels were within normal limits in all subjects tested. Median plasma citrulline was 25.7 µmol/L (IQR 19.8–31.3 µmol/L). Median plasma arginine was 57.8 µmol/L (IQR 39.4–72.7 µmol/L) and median urine arginine was 0.0014 µmol/L (IQR 0.001–0.003 µmol/L). Ten subjects (23.3%) suffered from diabetes mellitus type 2 (Table 1).

3.2. Correlation of plasma citrulline and basolateral membrane amino acid transporters

Plasma citrulline correlated with the mRNA expression of basolateral amino acid transporter LAT4 (Spearman's $r = 0.467$, $p = 0.028$) (Fig. 1). None of the other six basolateral membrane transporters/transport units assessed (LAT1 [SLC7A5], LAT2 [SLC7A8], 4F2hc [SLC3A2], y + LAT1 [SLC7A7], y + LAT2 [SLC7A6], TAT1 [SLC16A10]) significantly correlated with plasma citrulline. When performing the same analysis using a different reference

Table 1
Baseline Demographics of the 43 subjects.

Male Gender, n (%)	19 (44.2)
Age, median (IQR)	60 (49–66)
BMI [kg/m ²], median (IQR)	26.6 (22.9–29.1)
Diabetes mellitus, n (%)	10 (23.3)
- HbA1c [%], median (IQR)	- 6.5 (6.3–6.9)
Creatinine in plasma [μmol/L], median (IQR)	72.5 (63.5–82.0)
Citrulline in plasma [μmol/L], median (IQR)	25.7 (19.8–31.3)
Arginine in plasma [μmol/L], median (IQR)	57.8 (39.4–72.7)
Arginine in urine [μmol/L], median (IQR)	0.0014 (0.001–0.003)
ALT [U/L], median (IQR)	25.5 (22.8–36.8)
AST [U/L], median (IQR)	27.5 (23.0–33.5)
Protein [g/L], median (IQR)	74.0 (71.5–77.3)
Albumin [g/L], median (IQR)	43.0 (42.0–45.8)

IQR = interquartile range.

gene (HPRT), plasma citrulline correlated with the expression of LAT4 (Spearman's $r = 0.727$, $p = 0.007$) and with LAT2 mRNA in the intestine (Spearman's $r = 0.447$, $p = 0.048$) (Table 2).

3.3. Correlation of plasma citrulline and LAT4 mRNA expression in non-diabetic and non-obese subjects

Excluding all subjects with type 2 diabetes and/or BMI ≥ 30 kg/m² revealed a similar but not statistically significant correlation of plasma citrulline and LAT4 ($n = 31$ subjects without diabetes type 2 and BMI < 30 kg/m², Spearman's $r = 0.496$, $p = 0.060$) (Fig. 2).

3.4. Immunolocalization of LAT4 along the human intestine

To verify brush-border LAT4 protein expression, immunostaining for LAT4 was performed in sections from duodenum parts II (Fig. 3a; magenta) and III (Fig. 3b; magenta), terminal ileum (Fig. 3c; magenta) and ascending colon (Fig. 3d; magenta). In all regions, the transporter LAT4 localized to the basolateral enterocyte membrane. For better visualization, counterstaining of an arbitrary chosen apical membrane protein was performed. Therefore, the SARS-CoV-2 receptor ACE2 (green) was used. The signal of LAT4 appeared to be stronger towards the tips of the villi and weaker in the crypts (Fig. 3b; magenta). LAT4 staining appeared similar in duodenum (Fig. 3a and b; magenta) and terminal ileum (Fig. 3c; magenta) but was almost absent in colonic crypts (Fig. 3d).

Table 2
Correlation of plasma citrulline with basolateral amino acid transporter mRNA expression (Spearman's r).

	Relative to Villin		Relative to HPRT	
	Plasma citrulline		Plasma citrulline	
	Spearman's r	p-value	Spearman's r	p-value
LAT1	0.362	0.090	0.268	0.316
LAT2	-0.164	0.388	0.447	0.048
LAT4	0.467	0.028	0.727	0.007
4F2	-0.113	0.582	0.080	0.738
y ⁺ LAT1	-0.125	0.519	0.242	0.318
y ⁺ LAT2	0.286	0.175	0.179	0.524
TAT1	-0.165	0.383	0.268	0.443

P-values < 0.05 are given in bold.

3.5. Correlation of plasma citrulline with body mass index

Plasma citrulline did not correlate with BMI (Spearman's $r = 0.099$, $p = 0.579$) (data not shown).

3.6. Correlation of plasma citrulline with its metabolite arginine in the urine

Plasma citrulline concentration correlated with urinary arginine concentration (Spearman's $r = 0.419$, $p = 0.017$) (Fig. 5). Plasma citrulline did not correlate with urinary arginine when corrected to plasma creatinine levels (Spearman's $r = 0.235$, $p = 0.189$). None of the other urinary amino acids (histidine, asparagine, taurine, serine, glutamine, glycine, aspartate, glutamate, threonine, alanine, proline, ornithine, cysteine, lysine, tyrosine, methionine, valine, isoleucine, leucine, phenylalanine, tryptophan and citrulline itself) correlated with plasma citrulline or its precursors (glutamine, arginine, proline, glutamate or ornithine) (data not shown).

4. Discussion

Blood plasma citrulline concentration was shown to correlate with small intestinal LAT4 mRNA expression, which was further demonstrated on the protein level to localize to the basolateral membrane of enterocytes. Therefore, LAT4 might have an important function in mediating citrulline efflux from enterocytes.

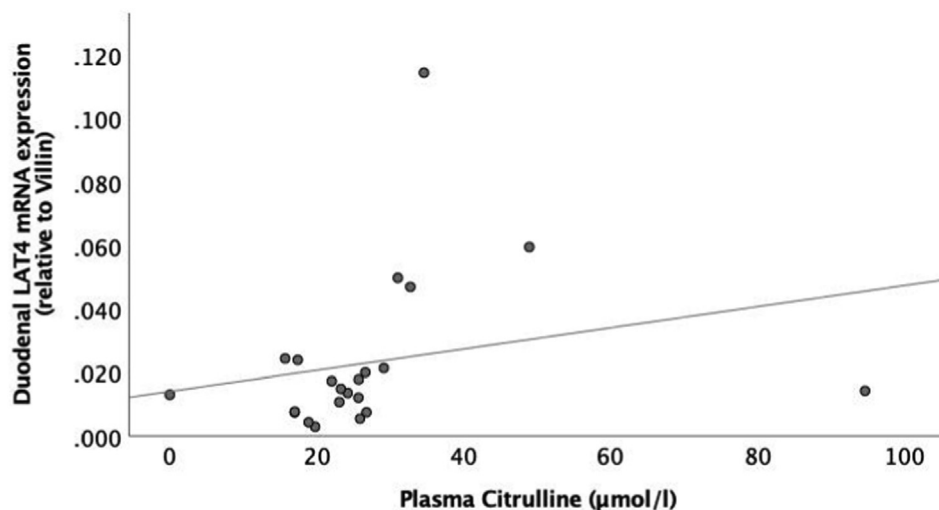

Fig. 1. Linear correlation of plasma citrulline concentration with the mRNA expression of baso-lateral LAT4. Duodenal mRNA expression [normalised to villin ($2^{Ct(\text{Villin}) - Ct(\text{target})}$)] of LAT 4 was correlated to plasma citrulline levels.

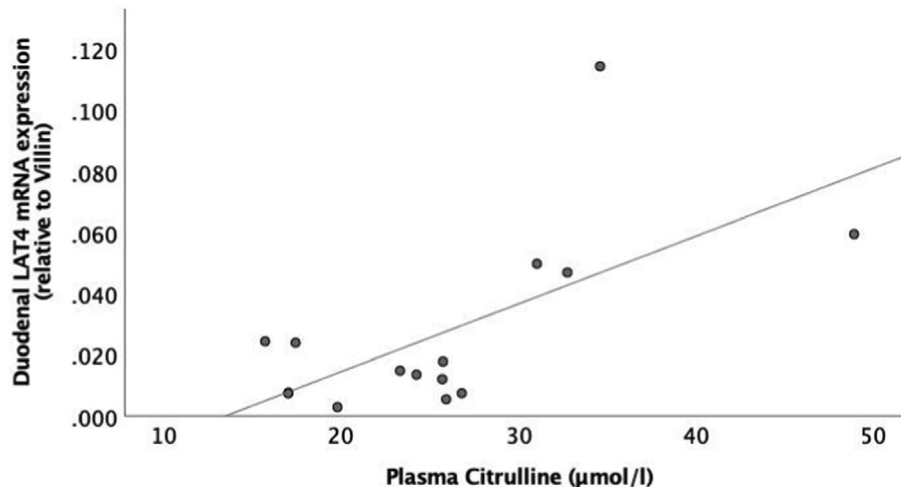

Fig. 2. Correlation of plasma citrulline and LAT4 mRNA expression in non-diabetic and non-obese subjects. Duodenal mRNA expression [normalised to villin ($2^{Ct(\text{Villin}) - Ct(\text{target})}$)] of LAT 4 was correlated to plasma citrulline levels in patients excluding all subjects with type 2 diabetes and/or BMI ≥ 30 kg/m² (n = 31).

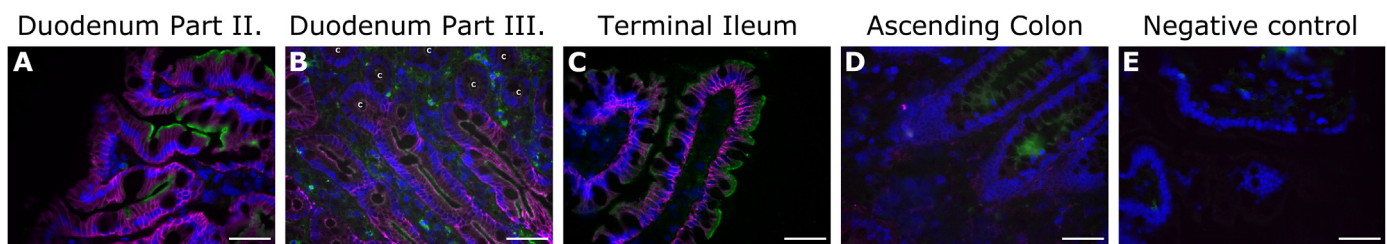

Fig. 3. Immunolocalization of LAT4 along the human intestine. Representative tissue specimens from duodenum parts II (3a), III (3b) and terminal ileum (3c) show LAT4 at the basolateral membrane (magenta) and ACE2 at the brush-border membrane of enterocytes (green) lining small intestinal villi. The signal of LAT4 appeared to be stronger towards the tips of the villi and weaker in the crypts ('c' in Figure 3b). A much weaker signal as compared to the small intestine was detected in colonic crypts (3d). Cellular DNA (3a-e; DAPI) is shown in blue to display the nuclei. Pictures were taken at 40x magnification. The bars represent 50 µm. A negative control without adding primary antibodies is depicted in 3e. (For interpretation of the references to colour in this figure legend, the reader is referred to the Web version of this article.)

Because there is no evidence for a direct transport of citrulline by LAT4, we hypothesize that there is a functional interaction with other basolateral amino acid transporters. Furthermore, plasma citrulline correlated with urinary arginine indicating that the latter could be a new and less invasive biomarker of enterocyte mass, although further study is needed.

Circulating plasma citrulline concentration has previously been shown to correlate with small intestine enterocyte mass in humans [15,29,30]. Notably, plasma citrulline likely depends on multiple intestinal processes, including absorption of dietary precursor amino acids [31,32], *de novo* synthesis of citrulline from precursor amino acids by small intestinal enterocytes, transcellular transport rate, metabolism in other organs [33], and metabolite excretion in the kidney [34]. Using a cohort of human subjects without known kidney failure and normal blood creatinine levels, without inflammatory intestinal diseases, investigated following overnight fasting, we were able to control some of these potentially confounding factors. As obesity and type 2 diabetes were shown to be linked to intestinal barrier damage resulting in increased intestinal permeability [35–38], a subgroup analysis was performed excluding subjects with type 2 diabetes and/or BMI ≥ 30 kg/m². LAT4 mRNA and plasma citrulline in non-obese and non-diabetic subjects hereby showed a comparable but not statistically significant correlation. We correlated plasma citrulline with intestinal mRNA-, but not protein expression, hereby neglecting a potentially deferred mRNA translation, post-translational modification, protein stabilization and/or regulation. As the presence of LAT4 in the basolateral

enterocyte membrane was previously only demonstrated in rodents [8], our study provides evidence that this localization of LAT4 to the basolateral enterocyte membrane is conserved in humans and along the entire small intestine.

Notably, we did not control for multiple variables in our study. Tissue specimens for qPCR analysis were isolated from the duodenum. It has previously been shown that gene expression of certain AA transporters can vary along the digestive [5,39]. Several additional factors may impact transporter gene expression and therefore bias the interpretation of our results, including disease state, diet [7,10,40,41], circadian rhythm [7], drugs [5], functional interactions among different transporters and the presence of accessory proteins [42,43]. Moreover, higher expression of a particular transporter does not necessarily result in more transport. Nevertheless, it is important to note that the proximal intestine (duodenum plus jejunum) is the predominant site for citrulline biosynthesis in the gut [19]. With regard to statistical analysis, subsequent Bonferroni correction for multiple testing was not applied, despite performing multiple analyses. As correlation coefficients for n = 7 duodenal transporters were calculated, a p-value of 0.028 cannot be considered statistically significant ($p < 0.05/7 = 0.007$; $0.028 > 0.007$) correcting for multiple testing (according to Bonferroni). Nevertheless, performing the same analysis using another reference gene (HPRT instead of Villin) resulted in a correlation coefficient of 0.727 and a p-value of 0.007. Plasma and urine amino acid concentrations were assessed using UPLC analysis in the present study. Median citrulline levels (25 µmol/L) were

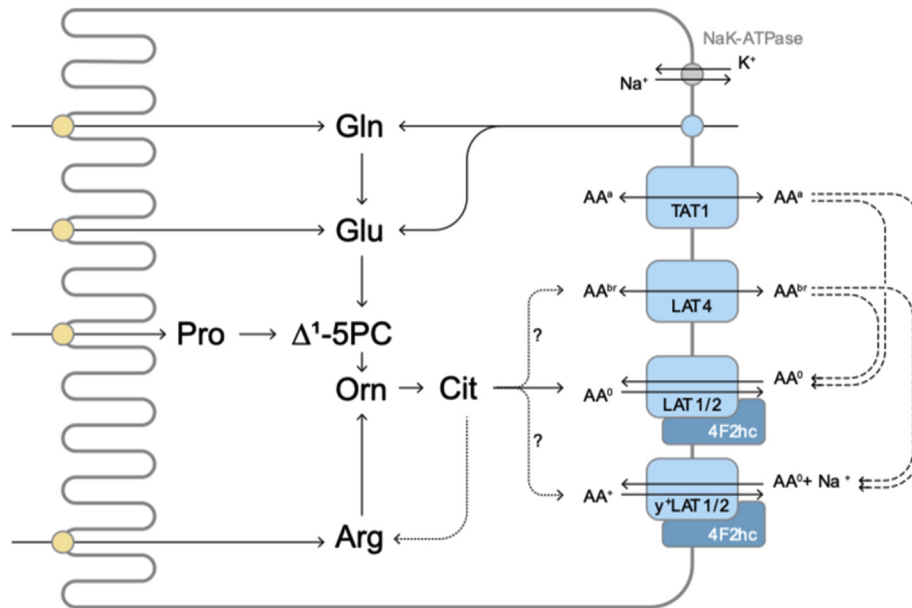

Fig. 4. Cell diagram of metabolism and possible transport of citrulline and its precursors in enterocytes. Intracellular citrulline metabolism and basolateral transporters involved in citrulline efflux from a small intestinal enterocyte are shown. Gln = glutamine; Glu = glutamate; Pro = proline; Δ^1 5PC = 1-pyrroline-5-carboxylic acid; Orn = ornithine; Cit = citrulline; Arg = arginine; AA⁰ = neutral amino acids, AA⁺ = cationic amino acids, AA^a = aromatic amino acids; AA^{br} = branched-chain amino acids. Bidirectional arrows indicate facilitated diffusion through uniporters, arrows pointing at opposite directions indicate amino acid exchange. Dashed arcuate arrows indicate interactions between different amino acid transporters through extracellular recycling of amino acids. Intracellular dotted arrows marked by an interrogation point indicate possible but questionable routes of Citrulline. Enzymes catalyzing synthesis reactions have been omitted for a clearer overview.

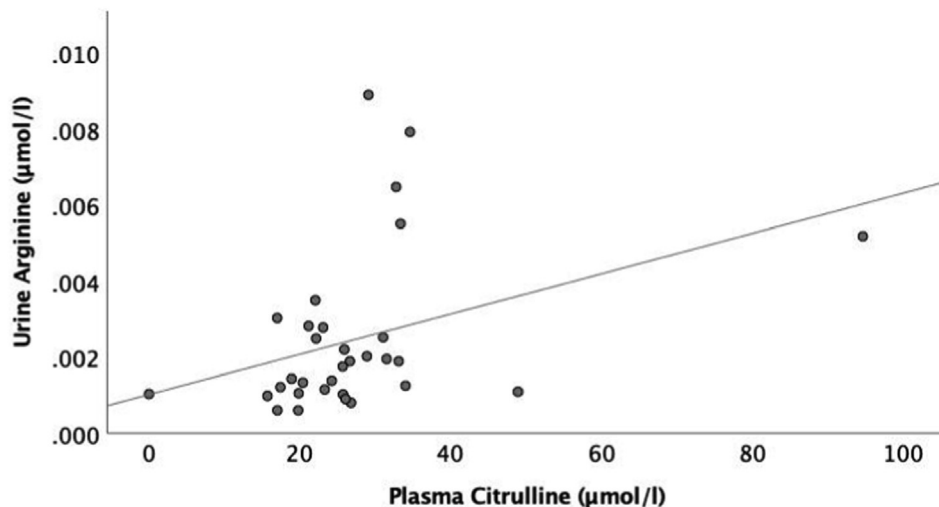

Fig. 5. Linear correlation of plasma citrulline and urinary arginine concentration. Plasma citrulline was correlated to urinary arginine.

lower compared to those reported in a previous study by Crenn et al. (40 $\mu\text{mol/L}$), which were assessed by ion exchange chromatography (IC) [44]. Plasma levels of other amino acids were comparable to those reported in previous studies [10], and between-run precision rates for High Performance Liquid Chromatography (HPLC)/UPLC and IC are below 7.5% [45,46]; the observed difference most likely reflects technical differences between the two chromatography techniques (UPLC vs. IC). Finally, absolute urine AA concentrations were used in the present study that were not corrected to urinary creatinine concentration to calculate fractional AA excretion.

We analyzed the expression of different known intestinal basolateral transporters which might be involved in handling of citrulline, namely the basolateral uniporters LAT4 and TAT1, as well

as the AA exchangers LAT1/2-4F2hc and γ -LAT1/2-4F2hc, and correlated transporter (subunit) mRNA expression with blood plasma citrulline concentration. According to our findings, LAT4 mRNA expression correlates with blood plasma citrulline levels in humans. This finding supports the findings by Guetg et al. showing reduced citrulline levels in the amniotic fluid, as well as in blood plasma in *Slc43a2* knockout mice not expressing amino acid transporter LAT4 [8].

According to previous studies, LAT4 has relatively narrow transporter characteristics and shows specificity for branched-chain AAs (leucine, isoleucine, valine) [10], as well as for phenylalanine and methionine [8]. Therefore, it seems unlikely that it would transport the large neutral amino acid citrulline. However, LAT4 is known to functionally interact with the basolateral

obligatory exchangers LAT1/2 and y^+ LAT1/2, which are suggested citrulline transporters [8,47–49]. In the intestine, LAT2 and y^+ LAT1 are most abundant [5]. Mutation of the basolateral y^+ LAT1, a known arginine transporter, has been identified to cause lysinuric protein intolerance (LPI), a rare hereditary disease characterized by the incapacity of intestinal absorption and renal reabsorption of the dibasic amino acids lysine, arginine and ornithine [50]. Experiments with oral amino acid loading showed intact citrulline absorption in patients suffering from LPI compared to controls [51]. Therefore, it seems unlikely that y^+ LAT1 is involved in citrulline release over the basolateral membrane of enterocytes.

Although we can only report correlations, we speculate that citrulline is transported by heterodimeric basolateral transporters of large amino acids LAT2 (or LAT1), but the driving force for its gradient may be generated by LAT4 (Fig. 4).

Plasma citrulline, that is not further metabolized in different tissues is taken up by renal epithelial cells – mainly in the proximal tubules – and converted to arginine by argininosuccinate synthetase and argininosuccinate lyase and finally released by the kidney into systemic circulation [17]. Whereas arginine production from citrulline accounts for 60% of the overall *de novo* arginine synthesis in the human body, it accounts for only 5–15% of circulating arginine [17]. In order to identify a non-invasive marker of functional enterocyte mass, we correlated plasma citrulline with urinary amino acid concentrations. Here, urinary arginine, a citrulline metabolite, correlated with plasma citrulline concentrations. Interestingly neither citrulline, nor proteinogenic amino acids in the urine correlated with plasma citrulline. This finding indicates that urinary arginine might be an indirect marker for plasma citrulline concentration and a possible less invasive marker for enterocyte mass. Enhanced conversion of citrulline into arginine and release from the kidney might finally result in a higher concentration of arginine in urine. Therefore, we propose that future studies should assess a possible correlation of urinary arginine and enterocyte mass using either short-gut patients or animal models. However, our finding differs from a previous report that did not show an increased urinary arginine excretion upon oral citrulline supplementation, possibly due to arginine – among other functions in the human body – acting as a precursor for protein synthesis in different tissues [52].

Plasma citrulline did not correlate with body mass index (BMI) in our cohort of patients, which is contrary to previous findings in HIV-patients showing a positive correlation of plasma citrulline with BMI [53]. Our findings are, however, in agreement with other studies that showed plasma citrulline being independent of BMI and nutritional status [54,55].

5. Conclusion

Basolateral LAT4 expression correlates with plasma citrulline concentration in humans. This finding indicates LAT4 having an important function in mediating citrulline efflux from enterocytes. Furthermore, urine arginine correlates with blood plasma citrulline levels indicating a possible novel non-invasive marker of enterocyte mass.

Authorship

All authors contributed to the manuscript.

Source of funding

RNV-d-B was supported by a grant for the Doctorate of Medicine and of Philosophy (MD-PhD) students from the Swiss National

Foundation (Ref. 323530-123720). CS and PF are supported by the Peter Hans Hofschneider Professorship for Molecular Medicine.

Conflict of interest

None.

Acknowledgements

None.

References

- [1] Vries RG, Huch M, Clevers H. Stem cells and cancer of the stomach and intestine. *Mol Oncol* 2010;4(5):373–84.
- [2] Verrey F, Singer D, Ramadan T, Vuille-dit-Bille RN, Mariotta L, Camargo SM. Kidney amino acid transport. *Pflügers Archiv* 2009;458(1):53–60.
- [3] Daniel H. Molecular and integrative physiology of intestinal peptide transport. *Annu Rev Physiol* 2004;66:361–84.
- [4] Fairweather SJ, Broer A, O'Mara ML, Broer S. Intestinal peptidases form functional complexes with the neutral amino acid transporter B(O)AT1. *Biochem J* 2012;446(1):135–48.
- [5] Vuille-dit-Bille RN, Camargo SM, Emmenegger L, Sasse T, Kummer E, Jando J, et al. Human intestine luminal ACE2 and amino acid transporter expression increased by ACE-inhibitors. *Amino Acids* 2015;47(4):693–705.
- [6] Broer A, Juelich T, Vanslambrouck JM, Tietze N, Solomon PS, Holst J, et al. Impaired nutrient signaling and body weight control in a Na⁺ neutral amino acid cotransporter (Slc6a19)-deficient mouse. *J Biol Chem* 2011;286(30):26638–51.
- [7] Camargo SM, Vuille-dit-Bille RN, Mariotta L, Ramadan T, Huggel K, Singer D, et al. The molecular mechanism of intestinal levodopa absorption and its possible implications for the treatment of Parkinson's disease. *J Pharmacol Exp Therapeut* 2014;351(1):114–23.
- [8] Guetg A, Mariotta L, Bock L, Herzog B, Fingerhut R, Camargo SM, et al. Essential amino acid transporter Lat4 (Slc43a2) is required for mouse development. *J Physiol* 2015;593(5):1273–89.
- [9] Boday S, Martín L, Zorzano A, Palacín M, Estévez R, Bertran J. Identification of LAT4, a novel amino acid transporter with system L activity. *J Biol Chem* 2005;280(12):12002–11.
- [10] Vuille-Dit-Bille RN, Ha-Huy R, Stover JF. Changes in plasma phenylalanine, isoleucine, leucine, and valine are associated with significant changes in intracranial pressure and jugular venous oxygen saturation in patients with severe traumatic brain injury. *Amino Acids* 2012;43(3):1287–96.
- [11] Batra A, Keys SC, Johnson MJ, Wheeler RA, Beattie RM. Epidemiology, management and outcome of ultrashort bowel syndrome in infancy. *Arch Dis Child Fetal Neonatal Ed* 2017;102(6):F551–f6.
- [12] Choudhury RA, Yoeli D, Moore HB, Prins K, Kovler M, Goldstein SD, et al. STEP improves long-term survival for pediatric short bowel syndrome patients: a Markov decision analysis. *J Pediatr Surg* 2020 Sep;55(9):1802–8. <https://doi.org/10.1016/j.jpedsurg.2020.03.017>. Epub 2020 Mar 30.
- [13] Pironi L. Definitions of intestinal failure and the short bowel syndrome. *Best Pract Res Clin Gastroenterol* 2016;30(2):173–85.
- [14] Mangalat N, Teckman J. Pediatric intestinal failure review. *Children (Basel)* 2018;5(7).
- [15] Crenn P, Messing B, Cynober L. Citrulline as a biomarker of intestinal failure due to enterocyte mass reduction. *Clin Nutr* 2008;27(3):328–39.
- [16] Bahri S, Zerrouk N, Aussel C, Moinard C, Crenn P, Curis E, et al. Citrulline: from metabolism to therapeutic use. *Nutrition* 2013;29(3):479–84.
- [17] Curis E, Nicolis I, Moinard C, Osowska S, Zerrouk N, Benazeth S, et al. Almost all about citrulline in mammals. *Amino Acids* 2005;29(3):177–205.
- [18] Fragkos KC, Forbes A. Citrulline as a marker of intestinal function and absorption in clinical settings: a systematic review and meta-analysis. *Unit Eur Gastroenterol J* 2018;6(2):181–91.
- [19] Curis E, Crenn P, Cynober L. Citrulline and the gut. *Curr Opin Clin Nutr Metab Care* 2007;10(5):620–6.
- [20] Windmueller HG, Spaeth AE. Source and fate of circulating citrulline. *Am J Physiol* 1981;241(6):E473–80.
- [21] Wu G. Intestinal mucosal amino acid catabolism. *J Nutr* 1998;128(8):1249–52.
- [22] Fujita T, Yanaga K. Association between glutamine extraction and release of citrulline and glycine by the human small intestine. *Life Sci* 2007;80(20):1846–50.
- [23] Lighthart-Melis GC, van de Poll MC, Dejong CH, Boelens PG, Deutz NE, van Leeuwen PA. The route of administration (enteral or parenteral) affects the conversion of isotopically labeled L-[2-15N]glutamine into citrulline and arginine in humans. *J Parenter Enteral Nutr* 2007;31(5):343–8. discussion 9–50.
- [24] Marini JC, Didelija IC, Castillo L, Lee B. Plasma arginine and ornithine are the main citrulline precursors in mice infused with arginine-free diets. *J Nutr* 2010;140(8):1432–7.

- [25] Buijs N, Brinkmann SJ, Oosterink JE, Luttikhoud J, Schierbeek H, Wisselink W, et al. Intravenous glutamine supplementation enhances renal de novo arginine synthesis in humans: a stable isotope study. *Am J Clin Nutr* 2014;100(5):1385–91.
- [26] Tomlinson C, Rafi M, Ball RO, Pencharz PB. Arginine can be synthesized from enteral proline in healthy adult humans. *J Nutr* 2011;141(8):1432–6.
- [27] Bretscher A, Weber K. Villin: the major microfilament-associated protein of the intestinal microvillus. *Proc Natl Acad Sci U S A* 1979;76(5):2321–5.
- [28] Wang S, Wang B, He H, Sun A, Guo C. A new set of reference housekeeping genes for the normalization RT-qPCR data from the intestine of piglets during weaning. *PLoS One* 2018;13(9):e0204583.
- [29] Diamanti A, Panetta F, Gandullia P, Morini F, Noto C, Torre G, et al. Plasma citrulline as marker of bowel adaptation in children with short bowel syndrome. *Langenbeck's Arch Surg* 2011;396(7):1041–6.
- [30] Chiba M, Sanada Y, Toki A. Markers of enteral adaptation in pediatric short bowel syndrome. *Pediatr Int* 2017;59(8):911–6.
- [31] Ribel-Madsen A, Hellgren LJ, Brøns C, Ribel-Madsen R, Newgard CB, Vaag AA. Plasma amino acid levels are elevated in young, healthy low birth weight men exposed to short-term high-fat overfeeding. *Physiol Rep* 2016;4(23):e13044.
- [32] Sailer M, Dahlhoff C, Giesbertz P, Eidens MK, de Wit N, Rubio-Aliaga I, et al. Increased plasma citrulline in mice marks diet-induced obesity and may predict the development of the metabolic syndrome. *PLoS One* 2013;8(5):e63950.
- [33] Vuille-dit-Bille R, Ha-Huy R, Tanner M, Stover J. Changes in calculated arterio-jugular venous glutamate difference and SjvO₂ in patients with severe traumatic brain injury. *Minerva Anesthesiol* 2011;77:870–6.
- [34] Tang WH, Wang Z, Cho L, Brennan DM, Hazen SL. Diminished global arginine bioavailability and increased arginine catabolism as metabolic profile of increased cardiovascular risk. *J Am Coll Cardiol* 2009;53(22):2061–7.
- [35] Genser L, Aguanno D, Soula HA, Dong L, Trystram L, Assmann K, et al. Increased jejunal permeability in human obesity is revealed by a lipid challenge and is linked to inflammation and type 2 diabetes. *J Pathol* 2018;246(2):217–30.
- [36] Chelakkot C, Ghim J, Ryu SH. Mechanisms regulating intestinal barrier integrity and its pathological implications. *Exp Mol Med* 2018;50(8):103.
- [37] Cox AJ, Zhang P, Bowden DW, Devreux B, Davoren PM, Cripps AW, et al. Increased intestinal permeability as a risk factor for type 2 diabetes. *Diabetes Metab* 2017;43(2):163–6.
- [38] Damms-Machado A, Louis S, Schnitzer A, Volynets V, Rings A, Basrai M, et al. Gut permeability is related to body weight, fatty liver disease, and insulin resistance in obese individuals undergoing weight reduction. *Am J Clin Nutr* 2017;105(1):127–35.
- [39] Meier CF, Camargo SMR, Hunziker S, Leu S, Holland-Cunz SG, Verrey F, et al. Mucosal monosaccharide transporter expression in newborns with Jejunoileal atresia and along the adult intestine. *J Pediatr Gastroenterol Nutr* 2019;69(5):611–8.
- [40] Suzuki T, Douard V, Mochizuki K, Goda T, Ferraris RP. Diet-induced epigenetic regulation in vivo of the intestinal fructose transporter Glut5 during development of rat small intestine. *Biochem J* 2011;435(1):43–53.
- [41] Drozdowski LA, Clandinin T, Thomson AB. Ontogeny, growth and development of the small intestine: understanding pediatric gastroenterology. *World J Gastroenterol* 2010;16(7):787–99.
- [42] Singer D, Camargo SM, Ramadan T, Schafer M, Mariotta L, Herzog B, et al. Defective intestinal amino acid absorption in Ace2 null mice. *Am J Physiol Gastrointest Liver Physiol* 2012;303(6):G686–95.
- [43] Meier C, Camargo SM, Hunziker S, Moehrlen U, Gros SJ, Bode P, et al. Intestinal IMINO transporter SIT1 is not expressed in human newborns. *Am J Physiol Gastrointest Liver Physiol* 2018;315(5):G887–95.
- [44] Crenn P, Coudray-Lucas C, Thuillier F, Cynober L, Messing B. Postabsorptive plasma citrulline concentration is a marker of absorptive enterocyte mass and intestinal failure in humans. *Gastroenterology* 2000;119(6):1496–505.
- [45] Le Boucher J, Charret C, Coudray-Lucas C, Giboudeau J, Cynober L. Amino acid determination in biological fluids by automated ion-exchange chromatography: performance of Hitachi L-8500A. *Clin Chem* 1997;43(8 Pt 1):1421–8.
- [46] Terrlink T, van Leeuwen PA, Houdijk A. Plasma amino acids determined by liquid chromatography within 17 minutes. *Clin Chem* 1994;40(2):245–9.
- [47] Schmidlin A, Fischer S, Wiesinger H. Transport of L-citrulline in neural cell cultures. *Dev Neurosci* 2000;22(5–6):393–8.
- [48] Lee KE, Kang YS. Characteristics of L-citrulline transport through blood-brain barrier in the brain capillary endothelial cell line (TR-BBB cells). *J Biomed Sci* 2017;24(1):28.
- [49] Wileman SM, Mann GE, Pearson JD, Baydoun AR. Role of L-citrulline transport in nitric oxide synthesis in rat aortic smooth muscle cells activated with LPS and interferon-gamma. *Br J Pharmacol* 2003;140(1):179–85.
- [50] Broer S. Amino acid transport across mammalian intestinal and renal epithelia. *Physiol Rev* 2008;88(1):249–86.
- [51] Rajantie J, Simell O, Perheentupa J. Intestinal absorption in lysinuric protein intolerance: impaired for diamino acids, normal for citrulline. *Gut* 1980;21(6):519–24.
- [52] Rouge C, Des Robert C, Robins A, Le Bacquer O, Volteau C, De La Cochetiere MF, et al. Manipulation of citrulline availability in humans. *Am J Physiol Gastrointest Liver Physiol* 2007;293(5):G1061–7.
- [53] Crenn P, De Truchis P, Neveux N, Galperine T, Cynober L, Melchior JC. Plasma citrulline is a biomarker of enterocyte mass and an indicator of parenteral nutrition in HIV-infected patients. *Am J Clin Nutr* 2009;90(3):587–94.
- [54] Jianfeng G, Weiming Z, Ning L, Fangnan L, Li T, Nan L, et al. Serum citrulline is a simple quantitative marker for small intestinal enterocytes mass and absorption function in short bowel patients. *J Surg Res* 2005;127(2):177–82.
- [55] Papadia C, Sherwood RA, Kalantzis C, Wallis K, Volta U, Fiorini E, et al. Plasma citrulline concentration: a reliable marker of small bowel absorptive capacity independent of intestinal inflammation. *Am J Gastroenterol* 2007;102(7):1474–82.