



ORIGINAL ARTICLE

Normal and reverse flow injection–spectrophotometric determination of thiamine hydrochloride in pharmaceutical preparations using diazotized metoclopramide

Mouayed Q. Al Abachi, Hind Hadi*

Department of Chemistry, College of Science, University of Baghdad, Jadriyah, Baghdad, Iraq

Received 24 January 2012; accepted 10 April 2012

Available online 25 April 2012

KEYWORDS

Thiamine;
Metoclopramide;
Flow injection;
Spectrophotometry

Abstract Simple and sensitive normal and reverse flow injection methods for spectrophotometric determination of thiamine hydrochloride (THC) at the microgram level were proposed and optimized. Both methods are based on the reaction between THC and diazotized metoclopramide in alkaline medium. Beer's law was obeyed over the range of 10–300 and 2–90 $\mu\text{g/mL}$, the limits of detection were 2.118 and 0.839 $\mu\text{g/mL}$ and the sampling rates were 80 and 95 injections per hour for normal and reverse flow injection methods respectively. The application of both methods to commercially available pharmaceuticals produced acceptable results. The flow system is suitable for application in quality control processes.

© 2012 Xian Jiaotong University. Production and hosting by Elsevier B.V.
Open access under [CC BY-NC-ND license](#).

1. Introduction

Vitamin B1 (thiamine hydrochloride, THC), a water-soluble vitamin, plays an important biological role in the metabolic process of the carbohydrate in the human body. Therefore, the

accurate estimation of the level of vitamin B1 in the clinical setting as well as in food is very important [1–3]. Previous studies have utilized different techniques for the estimation of thiamine including electrochemical analysis method [4], spectrophotometry [5], high performance liquid chromatography [6] and spectrofluorimetry [7]. However, the use of flow injection spectrophotometric methods for determination of thiamine in pharmaceutical products is not very well explored [7–9]. The normal flow injection analysis technique (nFIA) involves the injection of a small volume of sample into a reagent carrier stream which flows through a thin bore tube to a spectrophotometer where the derivative is measured [10]. On the other hand, in the reverse flow injection analysis (rFIA) [11] a small volume of reagent solution is injected into a sample and carrier streams. In the current study, spectrophotometric methods have been described for the determination of THC through its reaction with diazotized metoclopramide in alkaline medium to form a colored product which can be detected spectrophotometrically.

*Corresponding author.

E-mail address: hindhadi13@yahoo.com (H. Hadi).



2. Materials and methods

2.1. Reagents

Standard THC solution (Industries and Medical Appliance, SDI, Samara, Iraq): stock solution (500 $\mu\text{g}/\text{mL}$) was prepared by dissolving 0.05 g of the pure compound in 100 mL of distilled water and serial dilutions with distilled water were made.

Diazotized metoclopramide (DMP) (Industries and Medical Appliance, SDI, Samara, Iraq): a solution of 5 mM was prepared daily by dissolving 0.1772 g of MP in distilled water. Then, a volume of 3 mL of 1 M hydrochloric acid (HCl) was displaced in a 100 mL volumetric flask. The mixture was then cooled to about 0–5 °C using an ice-bath for 5 min. This was followed by adding 0.04 g of sodium nitrite (Merck) to the mixture with continuous stirring. After 5 min, the volume was made up to the 100 mL mark with distilled water and several dilutions were prepared with distilled water.

Sodium hydroxide (NaOH, BDH, UK): a solution of 100 mM was prepared by dissolving 0.4 g of the base in 100 mL of distilled water.

2.2. Apparatus

All spectral and absorbance measurements were carried out using a digital double beam spectrophotometer (Shimadzu, UV-vis 260). A flow cell with 50 μL internal volume and 1 cm bath length was used for the absorbance measurements. A two-channel manifold (Fig. 1(a)) was employed for the nFIA. A peristaltic pump (Ismatec, Labortechnik Analytik, CH8152, Zurich, Switzerland) was used to transport the solutions. In addition, an injection valve (Rheodyne, Altex 210, Supelco, USA) was employed to provide appropriate injection volumes of standard solutions and samples while a flexible vinyl tubing (0.5 mm internal diameter) was used for the peristaltic pump. The reaction coil (RC) was of Teflon material with an internal diameter of 0.5 mm. The sample was injected into the stream of the base solution through the injection valve. The solutions were propelled by peristaltic pump with individual flow rate of 0.75 mL/min and the absorbance was measured at 510 nm. A rFIA manifold has been developed for direct analysis of

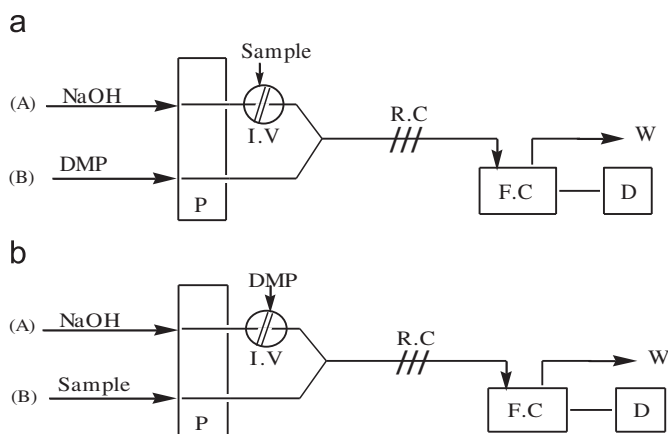

Figure 1 Schematic diagram of flow injection-spectrophotometric analysis. I.V, Injection valve; R.C, Reaction coil; P, Peristaltic pump; F.C, Flow cell; D, Detector (vis-spectrophotometer); W, Waste.

THC using a two-channel manifold (Fig. 1(b)). The reagent was injected into the stream of the base solution through the injection valve. Solutions were propelled by peristaltic pump with individual flow rate of 1.0 mL/min. The absorbance was measured at 510 nm.

2.3. Procedure

2.3.1. General batch procedure

An aliquot of sample containing 12.5–1125 μg of THC was transferred to a series of 25 mL standard flasks. A volume of 1 mL of 5 mM DMP solution and 1 mL of 100 mM of NaOH solution were added. The contents of the flasks were diluted to the mark with distilled water, mixed well and left for 20 min. The absorbance was measured at 510 nm at room temperature (25 °C) against reagent blank containing all materials except THC. A calibration graph was drawn and the regression equation was calculated. For the optimization of conditions in all subsequent experiments, a solution of 500 μg of THC was used and the final volume was 25 mL.

2.3.2. General nFIA procedure

Working solutions of THC in a range of 10–300 $\mu\text{g}/\text{mL}$ were prepared from the stock solutions. A 150 μL portion of THC was injected into the stream of 100 mM NaOH and was then combined with a stream of 5 mM DMP with a flow rate of 0.75 mL/min in each channel (Fig. 1(a)). The resulting absorbance of the red dye produced was measured at 510 nm. Moreover, optimization of conditions was carried out using 100 $\mu\text{g}/\text{mL}$ of THC.

2.3.3. General rFIA procedure

A 150 μL portion of 5 mM of DMP was injected into the stream of 70 mM NaOH which then combined with a stream of THC solution prepared in the range of 2–90 $\mu\text{g}/\text{mL}$ with a flow rate of 1 mL/min in each channel (Fig. 1(b)). The resulting absorbance of the red dye was measured at 510 nm. Optimization of conditions was carried out on 40 $\mu\text{g}/\text{mL}$ of THC.

2.3.4. Procedure for tablet and injection

An accurately weighed amount of ten powdered tablets or mixed content of ten vials, which is equivalent to 100 mg of the pure drug, was transferred to a 100 mL calibrated flask and completed to the mark with distilled water. The flask with its content was shaken well and then filtered. THC samples at 250, 500 and 750 μg in a final volume of 25 mL were prepared and the measurements were carried out as described earlier under general procedure.

2.3.5. Statistical analysis

Statistical analysis wherever required was performed using unpaired *t*-test using GraphPad Prism[®] v.5.00 (GraphPad Software, San Diego, CA, USA).

3. Results and discussion

The parameters affecting mainly the sensitivity and stability of the colored product were studied and optimized. Optimum conditions were established by changing one parameter at a time and keeping the others fixed by observing the effect produced on the

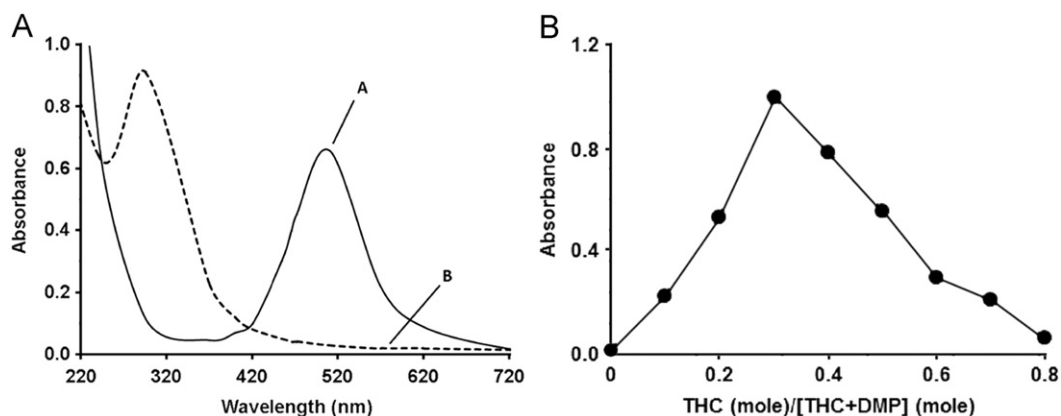
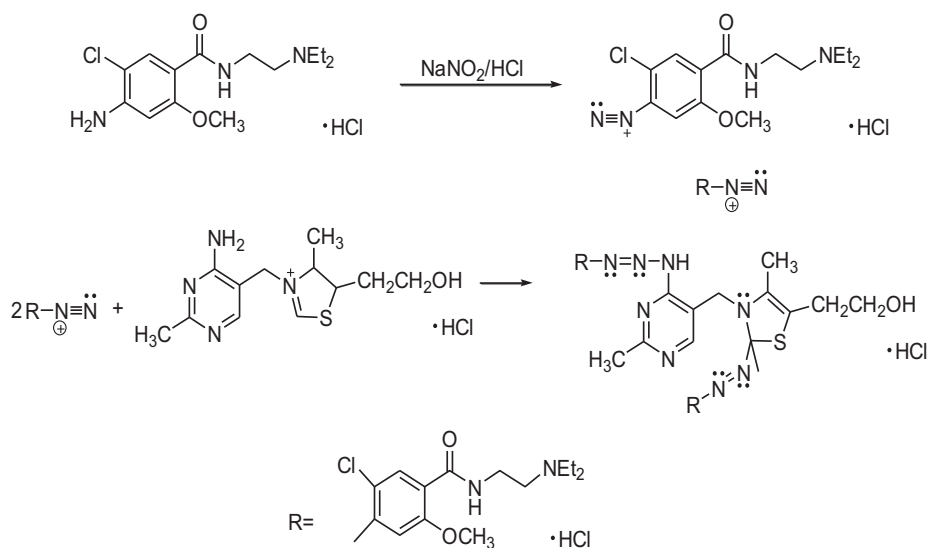

Figure 2 (a) Absorption spectra of 20 µg/mL of THC [A] measured against reagent blank while [B] is the reagent blank measured against distilled water, (b) Study of the mole ratio of the reaction between THC and DMP.



Scheme 1 Proposed mechanism of the reaction between THC and DMP.

absorbance of the colored species. THC forms a red-colored product (λ_{max} of 510 nm with a molar absorption coefficient of 9883 L/mole cm) with DMP in alkaline medium. The absorption spectra of the colored product are given in Fig. 2(a).

The aromatic amino group present in MP is diazotized with nitrous acid (NaNO_2/HCl) and the resultant diazonium salt is coupled with THC at room temperature. The stoichiometry of the reaction between each THC and DMP was investigated under the recommended optimum conditions by Job's method [12]. The results showed that a 1:2 (THC:DMP) ratio product is formed between the drug and diazotized reagent at 510 nm (Fig. 2(b)). Therefore, the free amino group of THC reacted with diazonium salt while the other diazonium molecule reacted through thiazole ring [13]. The stability constant of the dye product was $1.47 \times 10^{11} \text{ L}^2/\text{mol}^2$ and the reaction was carried out as described in Scheme 1.

3.1. Batch spectrophotometric determination

The red dye which was formed between THC and DMP had developed only in alkaline medium; therefore, the effect of different alkaline solutions was studied. The maximum

sensitivity and stability were obtained only when the reaction was carried out in the presence of NaOH solution. The best experimental conditions for the determination of THC were established for HCl (40–200 mM) which was used in diazotization of reagent, DMP (0.1–1 mM) and NaOH (1.2–20 mM) by varying one variable at a time and measuring the absorbance at 510 nm. The results showed that 120 mM of HCl, 0.2 mM of DMP and 4 mM of NaOH are the concentrations that can give the higher intensity and stability of the dye. The colored product is formed immediately and becomes stable after 20 min and remains for more than 90 min. A high absorbance was obtained when the color is developed at room temperature (25 °C) than when the flasks are placed in an ice-bath at 0 °C or in a water bath at 60 °C. The regression equation obtained from a series of THC standards, and the analytical figures of merits of this procedure are summarized in Tables 1 and 2.

3.2. Spectrophotometric determination for nFIA and rFIA

The batch method for the determination of THC was adopted to develop nFIA and rFIA procedures. Both manifolds used for the determination of THC were designed to provide

Table 1 Analytical features of the procedures developed for the determination of THC.

Parameter	Batch procedure	nFIA procedure	rFIA procedure
Regression equation	$Y=0.0293x-0.0026$	$Y=0.0031x+0.0212$	$Y=0.0056x+0.003$
Molar absorption coefficient (L/mole cm)	9.883×10^3	1.046×10^3	1.888×10^3
Linear range ($\mu\text{g/mL}$)	0.5–45	10–300	2–90
Correlation coefficient	0.9994	0.9994	0.9990
Limit of detection ($S/N=3$) ($\mu\text{g/mL}$)	0.295	2.115	0.839
Reproducibility (%)	<2.13	<0.98	<1.46
Recovery (%)	99.14	98.87	99.45
Through-put (1/h)	3	80	95

Table 2 Application of the proposed and official methods to the determination of THC in different dosage forms.

Dosage form	Proposed methods									Official method recovery (%)
	Batch			nFIA			rFIA			
	Present Conc. ($\mu\text{g/mL}$)	Recovery ^a (%)	RSD ^a (%)	Present Conc. ($\mu\text{g/mL}$)	Recovery ^a (%)	RSD ^a (%)	Present Conc. ($\mu\text{g/mL}$)	Recovery ^a (%)	RSD ^a (%)	
Vitamin B1 (100 mg tablet, SDI, Iraq)	10	102.83	1.19	50	101.72	2.35	10	97.37	1.91	99.88
	20	99.52	1.61	100	99.38	0.99	30	98.68	1.06	
	30	99.58	0.99	200	99.37	0.90	50	100.67	0.72	
Vitamin B1 (100 mg/2 mL injection, MEHECO, China)	10	97.17	1.41	50	97.70	2.40	10	100.66	1.84	100.78
	20	101.53	1.39	100	100.31	2.11	30	99.34	1.09	
	30	101.68	0.59	200	99.06	1.33	50	101.00	1.43	

^aFor five determinations. Conc., concentration; RSD, relative standard deviation.

different reaction conditions for magnifying the absorbance signal generated by the reaction of THC with DMP in NaOH. The influences of different physical or chemical parameters on the intensity of the colored product were optimized as follows.

3.2.1. Optimization of reagents concentration

The effects of various concentrations of DMP in the range of 1–10 mM were investigated. A concentration of 5 mM gave the highest absorbance for both kinds of FI and was chosen for further use (Fig. 3(A) and (B)). Therefore, the effect of various concentrations of NaOH was studied in the concentration range of 20–300 mM and the greatest absorbance intensity was obtained with 70 and 100 mM for normal and reverse flow injection manifolds, respectively (Fig. 3(C)).

3.2.2. Optimization of manifold parameters

The results showed that a flow rate of 1.5 and 2 mL/min gave the highest absorbance for nFIA and rFIA, respectively, (Fig. 3(D)) and they were used in all subsequent experiments. The volume of the sample was varied between 50 and 250 μL using different lengths of sample loop and showed that a sample of 150 μL gave the best absorbance for both methods (Fig. 3(E)). Moreover, a coil length of 100 cm gave the highest absorbance for both nFIA and rFIA procedures (Fig. 3(F)) and was used in all subsequent experiments. A standard calibration graph, obtained from a series of THC standards

and the main analytical figures of merits of the developed procedures are indicated and compared in Table 1.

3.3. Analytical application

The proposed methods are simple and cost-effective for determination of THC. They are adequate in aqueous solution and in pharmaceutical samples at a concentration level of traces ($\mu\text{g/mL}$) without the need for previous separation steps, temperature or pH control. The procedures have also good linearity, sensitivity and economical value compared to other methods [14–16]. The precision of the methods was evaluated and a good recovery was obtained and they were applied successfully to the analysis of some pharmaceutical preparations containing THC (Table 2) and the results were in accordance with the official method [17].

4. Conclusions

The present study described simple and sensitive flow injection-spectrophotometric methods for the determination of THC at low concentration level. The application of both nFIA and rFIA methods to commercially available pharmaceuticals in quality control processes is therefore recommended because of the reliable results and the economic value.

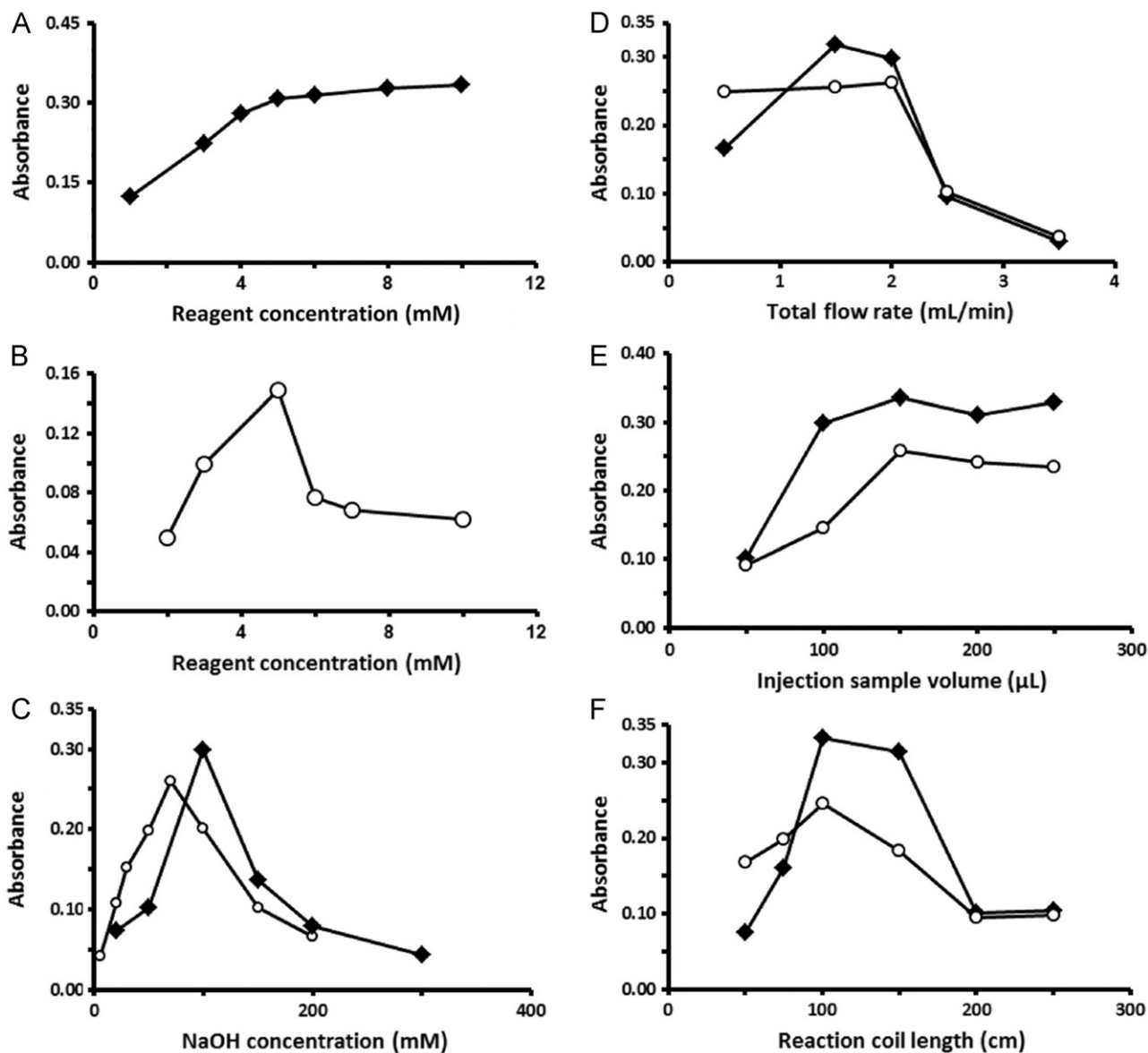

Figure 3 Effect of different parameters on nFIA (—◆—) or rFIA (—○—). (A) and (B), reagent concentration; (C), NaOH concentration; (D), total flow rate; (E), injection sample volume; (F), Reaction coil length.

Acknowledgments

We would like to thank the Department of Chemistry at University of Baghdad and the Industries and Medical Appliance, SDI, Samara, Iraq.

References

- [1] G.E. Gibson, L.C. Park, H. Zhang, et al., Oxidative stress and a key metabolic enzyme in Alzheimer brains, cultured cells, and an animal model of chronic oxidative deficits, *Ann. N.Y. Acad. Sci.* 893 (1999) 79–94.
- [2] A. Bâ, V. N'Douba, M.A. D'Almeida, et al., Effect of maternal thiamine deficiencies on the pyramidal and granule cells of the rat pups, *Acta Neurobiol. Exp.* 65 (2005) 387–398.
- [3] P. Pannunzio, A.S. Hazell, M. Pannunzio, et al., Thiamine deficiency results in metabolic acidosis and energy failure in cerebellar granule cells: an in vitro model for the study of cell death mechanisms in Wernicke's encephalopathy, *J. Neurosci. Res.* 62 (2000) 286–292.
- [4] E. Akyilmaz, I. Yas, E. Dinckaya, Whole cell immobilized amperometric biosensor based on *Saccharomyces cerevisiae* for selective determination of vitamin B1 (thiamine), *Anal. Biochem.* 354 (2006) 78–84.
- [5] J. Ghasemi, B. Abbasi, Simultaneous spectrophotometric determination of group B vitamins using parallel factor analysis: PARAFAC, *J. Chin. Chem. Soc.* 52 (2005) 1123–1129.
- [6] P. Viñas, C. López-Erroz, F.J. Cerdán, et al., Flow-injection fluorimetric determination of thiamine in pharmaceutical preparations, *Mikrochim. Acta* 134 (2000) 83–87.
- [7] O. Hassan, M.J. Chee, Sensitivity of UV detection in simultaneous separation and detection of B-vitamins using HPLC, *Malays. J. Anal. Sci.* 7 (2001) 251–255.
- [8] C.O. Costa-Neto, A.V. Pereira, C. Aniceto, et al., Flow injection turbidimetric determination of thiamine in pharmaceutical formulations using silicotungstic acid as precipitant reagent, *Talanta* 48 (1999) 659–667.

- [9] F.R. Rocha, O. Fatibello Filho, B.F. Reis, A multicommutated flow system for sequential spectrophotometric determination of hydrosoluble vitamins in pharmaceutical preparations, *Talanta* 59 (2003) 191–200.
- [10] J. Ruzicka, E.H. Hansen, Flow injection analysis. Part I: a new concept of fast continuous flow analysis, *Anal. Chim. Acta* 78 (1975) 145–157.
- [11] K.S. Johnson, R.L. Petty, Determination of phosphate in seawater by flow injection analysis with injection of reagent, *Anal. Chem.* 54 (1982) 1185–1191.
- [12] L.G. Hargis, *Analytical Chemistry: Principles and Techniques*, Prentice-Hall, Inc., New Jersey, 1998.
- [13] H.J. Prebluda, E.V.A Mccollum, Chemical reagent for thiamine, *J. Biol. Chem.* 127 (1939) 495–503.
- [14] T. Pérez-Ruiz, C.M. Lozano, A. Sanz, et al., Successive determination of thiamine and ascorbic acid in pharmaceuticals by flow injection analysis, *J. Pharm. Biomed. Anal.* 34 (2004) 551–557.
- [15] J.M. Calatayud, C.G. Benito, D.G. Gimenez, FIA-fluorimetric determination of thiamine, *J. Pharm. Biomed. Anal.* 8 (1990) 667–670.
- [16] J. Zou, X. Chen, Using silica nanoparticles as a catalyst carrier to the highly sensitive determination of thiamine, *Microchem. J.* 86 (2007) 42–47.
- [17] *British Pharmacopoeia* Her Majesty Stationary Office, London, 1993.