



## Improved modification of clinoptilolite with silver using ultrasonic radiation

Z. Znak<sup>a,\*</sup>, O. Zin<sup>a</sup>, A. Mashtaler<sup>a</sup>, S. Korniy<sup>b</sup>, Yu. Sukhatskiy<sup>a</sup>, Parag R. Gogate<sup>c,\*</sup>, R. Mnykh<sup>a</sup>, Pooja Thanekar<sup>c</sup>

<sup>a</sup> Institute of Chemistry and Chemical Technologies, Lviv Polytechnic National University, Bandera Str., Lviv 79013, Ukraine

<sup>b</sup> Karpenko Physico-Mechanical Institute of the NAS of Ukraine, Naukova Str., Lviv 79060, Ukraine

<sup>c</sup> Department of Chemical Engineering, Institute of Chemical Technology, Matunga, Mumbai 40019, India

### ARTICLE INFO

**Keywords:**  
Clinoptilolite  
Silver ions  
Ultrasound  
Sorption capacity  
Diffusion  
Improved synthesis

### ABSTRACT

The modification of natural clinoptilolite with silver ions using ultrasound has been investigated in the current work. The modification process was performed using clinoptilolite of different fractions (0–3.0 mm) over the temperature range of 25–55 °C, ultrasonic power range of 8.0–12.5 W and AgNO<sub>3</sub> concentration range of 0.01–0.1 M. The zeolite modification was performed in the presence of sonication and mechanical stirring in separate runs for comparison. Fundamental analysis demonstrated that the use of ultrasound ensures desorption of air from clinoptilolite particles and accelerates the diffusion of Ag<sup>+</sup> ions and subsequent ion exchange. Increasing the particle size of clinoptilolite led to a natural decrease in its sorption capacity. A slight increase in the sorption capacity with an increase in the equivalent particle diameter from 0.081 to 0.35 mm was seen due to changes in the structure of clinoptilolite particles during mechanical grinding. The calculated temperature coefficient of the sorption process of Ag<sup>+</sup> ions as <1.47 means that the modification takes place with dominant control in the intradiffusion region. Increasing the power of ultrasonic irradiation did not provide a monotonous change in the sorption capacity of clinoptilolite. Increasing the concentration of argentum nitrate solution provided an increase in the content of silver ions in clinoptilolite. In general, the advantage of using ultrasonic vibrations to modify the natural clinoptilolite of different fractions with Ag<sup>+</sup> ions was demonstrated in terms of achieving higher sorption capacity, also elucidating the effect of different operating conditions.

### 1. Introduction

Natural zeolites are unique materials characterized by strong cation exchange capacity [1] and high sorption capacity for many types of chemical compounds [2]. Cation exchange capacity is due to the presence of cations Na<sup>+</sup>, K<sup>+</sup>, Ca<sup>2+</sup> and Mg<sup>2+</sup> in the material whereas higher sorption capacity is explained by the presence of a fairly ordered system of macro-, meso- and microchannels [3] in the structure. One of the important type of zeolite is clinoptilolite which has been reported to be efficient for adsorbing heavy metal ions [4–9], radionuclides [10] and many harmful and toxic substances of various origins. At the same time, clinoptilolite offers an important advantage over many other zeolites as the application in food products or suitability to the food processing. As a specific example, clinoptilolite is used as an additive to some foods such as bread, feed, poultry, and fish [1,11]. Considering the suitability in food chain, clinoptilolite also serves as a leading filter in natural water

treatment technologies [12]. In recent years, this zeolite is also increasingly used in cosmetology [13], in medicine [14] in particular in the manufacture of drugs with antiviral properties [15,16].

The effectiveness of clinoptilolite as an additive to food products, as sorbent in medicines or cosmetics [17] or as filter material is significantly increased if it is modified with silver in the form of highly dispersed or nanosized particles or Ag<sup>+</sup> ions. Silver nanoparticles have specific antimicrobial properties in many substrates and composites [18–20]. Therefore, some researchers consider silver nanoparticles as a new generation of antimicrobials [21]. Their properties as a disinfectant and the conditions under which these properties are manifested have been studied quite thoroughly [22] and it is reported that the effectiveness of silver nanoparticles as a disinfectant depends on the dose, size and shape as well as method of synthesis especially for the case of silver coupled with clinoptilolite. For example, a study reported that the state of silver and its particle size in the embedded natural zeolite

\* Corresponding authors.

E-mail addresses: [znak\\_zo@ukr.net](mailto:znak_zo@ukr.net) (Z. Znak), [pr.gogate@ictmumbai.edu.in](mailto:pr.gogate@ictmumbai.edu.in) (P.R. Gogate).

<https://doi.org/10.1016/j.ultsonch.2021.105496>

Received 30 November 2020; Received in revised form 17 January 2021; Accepted 10 February 2021

Available online 16 February 2021

1350-4177/© 2021 The Author(s).

Published by Elsevier B.V. This is an open access article under the CC BY-NC-ND license

(<http://creativecommons.org/licenses/by-nc-nd/4.0/>).

depends on the temperature used in the synthesis [23]. The antimicrobial action of silver, in particular nanoparticles, is caused by the oxidizing action of  $\text{Ag}^+$  ions, which are desorbed from their surface. The antimicrobial action of  $\text{Ag}^+$  ions is manifested by interaction with the cell wall [24] and subsequent penetration into the DNA, because of which the cell loses the ability to replicate, which causes its death [25], thus making the efficient release of  $\text{Ag}^+$  ions an important factor.

The use of silver-modified natural and synthetic zeolites for disinfection of natural water [26,27] and wastewater [28] is well known due to the high oxidizing ability of silver, in particular its ions, which provides antibacterial action of composites based on modified zeolite, in particular clinoptilolite [29]. Silver ions have a greater antibacterial effect than silver in the form of particles, because the equilibrium concentration of silver ions over metallic silver is negligible. Therefore, zeolites, modified with silver ions, are often used. It is expected that during the modification of clinoptilolite, silver ions are absorbed by two mechanisms: ion exchange and sorption of silver salt ( $\text{AgNO}_3$ ), which is used in this process. Thus, modified clinoptilolite with silver particles or ions in different processes can simultaneously perform several functions, including sorption of harmful and toxic compounds, as well as inhibit the development or neutralize microorganisms, including pathogens. It is important to note that the greatest role in the suppression of microorganisms is played by silver (in the form of particles or ions), which is localized on the surface of the particle and in its near-surface layer attributed to the rather large size of the bacteria and their complicated diffusion into the clinoptilolite particle.

In the case of applied silver modified clinoptilolite, for example, in water filters, the silver content slowly decreases and hence its antibacterial action weakens. If silver is contained in clinoptilolite in the form of ions, then the reduction of their content occurs by two mechanisms: the first as ion exchange for cations contained in water and the second by desorption of silver ions together with a counterion (anion). The diffusion of silver ions and the ion exchange play an important role in these processes. These considerations give reason to believe that the loss of silver ions from the near-surface layers of clinoptilolite can be compensated by their diffusion from the inner region of the zeolite particles to the periphery. To do this, it is necessary to ensure the highest possible content of silver ions in the inner regions of the clinoptilolite particle. The saturation of the zeolite particle with  $\text{Ag}^+$  ions occurs due to their diffusion. Obviously, the slowest diffusion occurs in the meso- and, especially, micropores. At the same time, additional diffusion resistance is created by air that blocks mostly the microchannels of clinoptilolite. The implementation of the modification process, even at reduced pressure, which should ensure desorption of gas, can not significantly increase the sorption capacity of the zeolite. Use of ultrasound due to the action of acoustic oscillations can aid in release of air bubbles [30]. The effect of ultrasound on desorption of gases or other substances from porous materials is well known [31]. These observations give reason to hope that the implementation of modifications using ultrasound radiation will achieve greater sorption capacity of clinoptilolite for silver ions. In addition, the diffusion of ions is known to be intensified by the action of ultrasonic vibrations. Previous research [30] showed that the number of equivalents of silver ions in clinoptilolite can be greater than the cation exchange capacity of this zeolite. This phenomenon is known as superequivalent adsorption [32] and means that silver ions are absorbed by the clinoptilolite particle due to ion exchange and sorption of the silver salt.

Literature analysis revealed that there is almost no information in the available sources on the effect of ultrasound on the process of modification of natural clinoptilolite by silver ions. Therefore, this work focuses on the study of modification of natural clinoptilolite by silver ions under the action of ultrasound under isothermal conditions. The novelty of the work is to determine the influence of ultrasound and various technological factors on the features of sorption of silver ions by clinoptilolite and to establish the kinetic parameters of the sorption process parameters.

## 2. Materials and methods

### 2.1. Materials

Natural clinoptilolite from the Sokyrnytsia deposit in the Zakarpattia region (Ukraine) was used. All the studies were performed from same batch of the natural material obtained from the deposit so as to avoid any batch to batch variation in the starting feed stock. Mineral composition of the rock was (wt %): clinoptilolite – 70–80%; montmorillonite – 2–5%; quartz – 5–10%; feldspar – 5–10%; carbonate – 1–3% and mica – 1–3%. Chemical composition of the clinoptilolite (the content of elements is expressed in terms of their higher oxides) can be expressed as (wt %)  $\text{SiO}_2$  – 65.0–71.3%;  $\text{Al}_2\text{O}_3$  – 11.5–13.1%;  $\text{CaO}$  – 2.7–5.2%;  $\text{K}_2\text{O}$  – 2.2–3.4%;  $\text{Fe}_2\text{O}_3$  – 0.7–1.9%;  $\text{MgO}$  – 0.6–1.2%;  $\text{Na}_2\text{O}$  – 0.2–1.3%;  $\text{TiO}_2$  – 0.1–0.3%;  $\text{MnO}$  – 0.04% and  $\text{P}_2\text{O}_5$  – 0.02%. In addition, the physical characteristics can be given as porosity – 38–46%, volume weight – 1.040–1.080  $\text{g/cm}^3$ , water absorbing capacity – 34–38% and cation exchange capacity – 1.23–1.50 mEq/g. The current study was performed using different zeolite fractions in the mm range: 0.063–0.01; 0.1–0.2; 0.3–0.4; 0.4–0.5; 0.63–0.8; 0.9–1.0; 1.0–1.5; 1.5–2.0; 2.0–2.5 and 2.5–3.0 mm (accordingly, the equivalent particle diameter was equal to 0.081; 0.15; 0.35; 0.45; 0.71; 0.95; 1.25; 1.75; 2.25 and 2.75, all in mm).  $\text{AgNO}_3$  (purity – “pure per analysis”) was obtained from STANLAB, Poland. Fresh distilled water prepared in the laboratory was used to prepare the  $\text{AgNO}_3$  solutions.

### 2.2. Experimental set up

Fig. 1 shows a representation of the setup used for the study of the modification of natural clinoptilolite under the action of ultrasound. The laboratory unit consists of a conical flask (volume 300 ml, throat diameter 26 mm) used for modification studies, an ultrasonic emitter “Ultrasonic Disintegrator UD-20”, a magnetic stirrer, a thermostat UTH-4 and a thermostat bath equipped with a thermometer. The glass flask has two side nozzles. In one nozzle, a thermometer is placed to monitor the temperature in the reaction medium, and through the other nozzle, samples of the modification solution are withdrawn for analysis for the content of silver ions. Isothermal conditions in the reaction medium are created by means of a thermostatic bath, connected by hoses. Ultrasound with a frequency of 20 kHz is transmitted to the reaction medium from the magnetostrictive emitter through a concentrator (made of stainless steel). The diameter of the working part of the concentrator of the ultrasonic emitter is 15 mm and the depth of immersion in the solution is  $10 \pm 1$  mm. The ultrasonic power emitter unit allows to discretely adjust

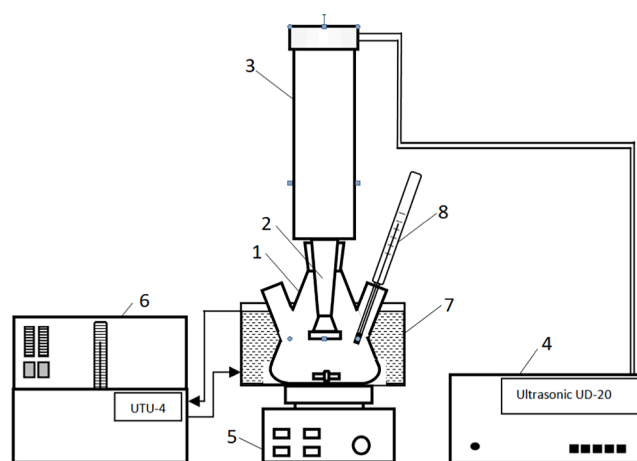

Fig. 1. Details of experimental setup involving ultrasonic emitter 1 – flask for modification; 2 – ultrasonic radiation concentrator; 3 – magnetostrictive emitter; 4 – power supply of the radiator; 5 – magnetic stirrer; 6 – thermostat; 7 – thermostatic bath; 8 – thermometer.

the power in the range of 8.0–12.5 W. The power of ultrasonic radiation was measured by calorimetric method [33].

### 2.3. Methodology

A solution of silver nitrate with a concentration of 0.1 M was prepared using distilled water. Sequential dilutions of this solution were obtained to get solutions of  $\text{AgNO}_3$  over the range of 0.05 and 0.01 M. The volume of  $\text{AgNO}_3$  solution taken in each experiment was 100 ml and the weight of clinoptilolite was  $10 \pm 0.05$  g (higher amounts used in the study helped in maintaining the reproducibility of the experimental results). The study was performed with constant stirring in turbulent mode at a temperature of  $25 \pm 0.5$  °C (isothermal mode of operation). In parallel, studies were performed without ultrasound to establish the efficacy of ultrasound.

To obtain the specified fractions, clinoptilolite with an initial size of 5–6 mm was crushed using a ball mill (volume 3 L, diameter of ball 20–30 mm). Frequency of rotation of the drum of mill was  $1 \text{ s}^{-1}$  with drum filling – 40% and the applied mass ratio of clinoptilolite to grinding bodies (porcelain balls) as 1:3. Sifting of ground clinoptilolite was performed using a mechanical classifier using a set of standard sieves.

### 2.4. Analysis

The concentration of silver ions in the medium was determined potentiometrically using an Ag-selective electrode (ESS-01) as a measuring and chloride-silver as a reference electrode (EVL-1M). The reference electrode was commutated with the modification solution through an electrolytic key filled with 0.1 N  $\text{KNO}_3$  solution. The electrodes were connected to an F-30 millivoltmeter. Before each cycle of studies, the Ag-selective electrode was calibrated using  $\text{AgNO}_3$  solutions of different concentrations ( $1 \times 10^{-4}$ ,  $1 \times 10^{-3}$ ,  $1 \times 10^{-2}$ ,  $1 \times 10^{-1}$  M). At the end of the experiment, clinoptilolite was separated by filtration using filter paper “Blue tape” (pore size, 3–5  $\mu\text{m}$ ). After that, the clinoptilolite on the filter was washed with 100 ml of distilled water. The concentration of silver ions was determined potentiometrically in this water. This amount of silver ions was taken into account when calculating the sorption capacity (S) of clinoptilolite using the following equation:

$$S = \frac{((C_0 - C) \times V - C_w \times V_w) \times M_{\text{Ag}}}{m} \quad (1)$$

where,  $C_0$  – initial concentration of  $\text{Ag}^+$  ions in solution, M; C – actual concentration  $\text{Ag}^+$  ions at a certain point in time, M;  $C_w$  – concentration of  $\text{Ag}^+$  ions in washing water, M; V – volume of modification solution, L;  $V_w$  – volume of wash water, L;  $M_{\text{Ag}}$  – molar mass of silver, g/mol and m – mass of clinoptilolite, g. The representative calculation of the sorption capacity has been represented in Appendix I.

The content of  $\text{Ag}^+$  ions and other cations ( $\text{Na}^+$ ,  $\text{K}^+$ ,  $\text{Mg}^{2+}$ ,  $\text{Ca}^{2+}$ ) in the composition of clinoptilolite before and after modification was determined by energy-dispersive micro-X-ray spectral analysis (EDX) using INCA Energy 350, which is integrated into the scanning electron microscope Zeiss EVO-40XVP.

The reproducibility of the results was verified by repeating the experiments performed in this work (only at higher concentrations of silver nitrate solution, some experiments were performed once as the runs were quite reproducible). The observed errors were within  $\pm 5\%$  of the reported values.

## 3. Results and discussion

### 3.1. Calibration study

The calibration curve of the Ag-selective electrode is shown in Fig. 2.

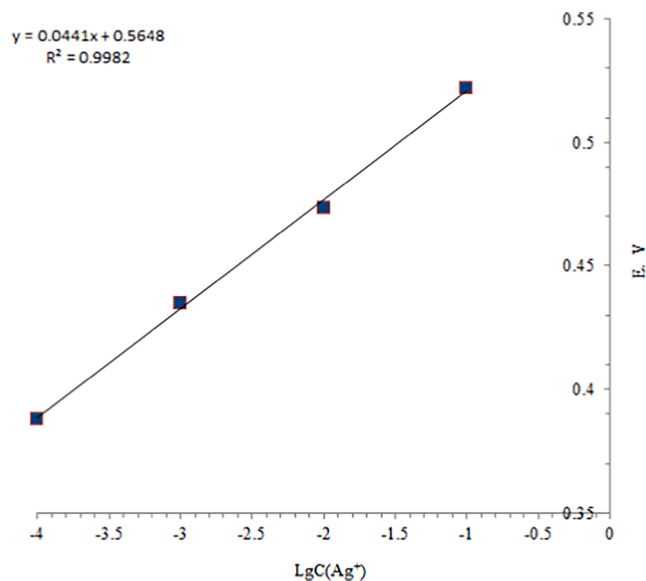

Fig. 2. Dependence of the potential of the Ag-selective electrode on the concentration of  $\text{Ag}^+$  ions (calibration curve of the electrode ESS-01, temperature as 25 °C).

The dependence of the potential of the Ag-selective electrode on the concentration of silver ions (in logarithmic form) is expressed by the equation  $E = 0.0441 \cdot \text{LogC}(\text{Ag}^+) + 0.5648$ . The value of the reliability of the approximation 0.9982 indicates the high accuracy of potentiometric determination of the concentration of silver ions over a wide range as investigated in the work.

### 3.2. Sorption of silver ions by clinoptilolite

#### 3.2.1. Influence of clinoptilolite size and use of ultrasound on sorption capacity

In the current study, different clinoptilolite sizes in terms of varying equivalent particle diameter as 0.081; 0.15; 0.35; 0.45; 0.71; 0.95; 1.25; 1.75; 2.25 and 2.75 mm were used due to the wide range of clinoptilolite sizes applied in different applications such as medicine, cosmetology, water purification, etc. The concentration of  $\text{AgNO}_3$  solution used for this set of experiments was fixed at 0.01 M. When using a solution of  $\text{AgNO}_3$  with a low concentration, the sorption rate of silver ions is not high. Therefore, it can be expected that the effect of using ultrasonic radiation will be greater than that expected at higher concentrations of  $\text{AgNO}_3$ . Power of ultrasonic radiation was fixed at 10.2 W (0.102 W/mL) and the operation mode was isothermal with temperature maintained at 25 °C.

First, the study was performed using clinoptilolite fraction of 1.0–1.5 mm, which is used in the application as the nozzle filters for water purification, at 25 °C. The change in the content of silver ions in the particles of clinoptilolite (sorption capacity of clinoptilolite) under the action of ultrasonic radiation and under mechanical mixing in the control experiment (mechanical mixing of the zeolite- $\text{AgNO}_3$  solution system) over time is shown in Fig. 3. It can be seen from the data that with mechanical mixing, the sorption capacity of clinoptilolite with dimensions of 1.0–1.5 mm (equivalent diameter of 1.25 mm) is equal to 7.791 mg/g ( $7.21 \times 10^{-2}$  mEq/g) whereas under the action of ultrasonic irradiation, the sorption capacity increases by 28% to 9.989 mg/g ( $9.25 \times 10^{-2}$  mEq/g). Danková et al. [34] also reported that the use of ultrasound increases the adsorption capacity of montmorillonite relative to cadmium ions by 40%.

The sorption process is known to follow a first-order mechanism. Therefore, the rate constant of this process ( $k$ ,  $\text{s}^{-1}$ ) was calculated by the analysis based on the equation given below:

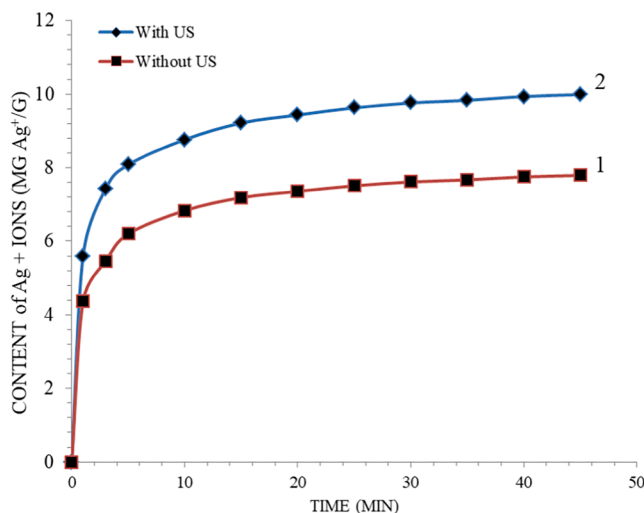

**Fig. 3.** The dependence of the content of  $\text{Ag}^+$  ions in clinoptilolite (1.0–1.5 mm) on time 1 – by mechanical mixing; 2 – under the action of ultrasound (ultrasonic power as 10.2 W (0.102 W/mL);  $\text{C}(\text{AgNO}_3) = 0.01 \text{ M}$ ; temperature as 25 °C).

$$k = \frac{1}{\tau} \ln \frac{C_0}{C} \quad (2)$$

where  $\tau$  – time, sec and  $C_0$ ,  $C$  are initial and actual concentration of silver ions in solution at time  $\tau$ , M.

The sorption rate constant under the action of ultrasound radiation was found to be  $0.0506 \text{ s}^{-1}$  whereas with mechanical stirring, the observed rate constant was  $0.0395 \text{ s}^{-1}$ . Thus, the application of the ultrasound causes an increase in the rate constant by almost 30%. Similar Significant increase in the sorption rate constant of cations  $\text{Li}^+$ ,  $\text{Ca}^{2+}$  and  $\text{Ce}^{3+}$  by zeolite NaX under the action of ultrasound was also established by Erten-Kaya et al. [35]. It was reported that the velocity constant under the action of ultrasound increased for  $\text{Li}^+$  ions by 2.25–3.36 times, for  $\text{Ca}^{2+}$  ions by 1.73–2.0 times and for  $\text{Ce}^{3+}$  ions by 1.37–5.5 times.

The process of modification of clinoptilolite with  $\text{Ag}^+$  ions ( $\text{Ag}^+$  sorption) occurs as a typical heterogeneous process. The rate of this process typically depends on the contact area of the solid and liquid phases and also on the film thickness leading to the mass transfer resistances. The contact area of the phases could not be exactly determined because the shape of the particles is far from circular or spherical (Fig. 4) and with decreasing size, their shape becomes more irregular. The observed intensification due to the use of ultrasound can be attributed to the fact that the turbulence generated by cavitation events leads to enhanced rates of mass transfer based on lower film thickness and also the particle size is reduced leading to higher available transfer area for the transfer.

It was also seen in the studies that on increasing the particle size of clinoptilolite to 2.5–3.0 mm (equivalent diameter of 2.75 mm), the efficiency of ultrasonic vibrations was greater than that obtained for particles with a size of 1.0–1.5 mm. In particular, the sorption capacity of particles with a size of 2.75 mm under the action of ultrasound increases by almost 56% compared to mechanical stirring (5.192 mg/g with stirring; 8.330 - under the action of ultrasound) as shown in Fig. 5. The rate constant of the sorption process under the action of acoustic irradiation was equal to  $0.0343 \text{ s}^{-1}$ , and in the control experiment (with stirring) it was  $0.0219 \text{ s}^{-1}$ . The use of ultrasound intensified the process by 1.57 times (by 57%). Therefore, with the increasing particle size of clinoptilolite, the efficiency of acoustic radiation increases significantly. This can be explained on the basis of lower mass transfer rates in the case of larger size particles and hence more effects of ultrasound in terms of turbulence seem to control the overall sorption process.

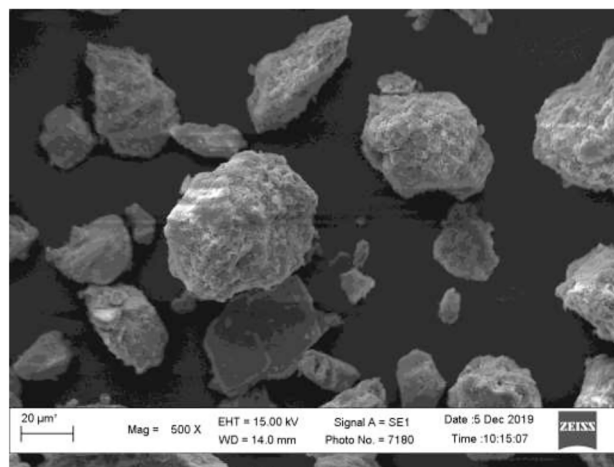
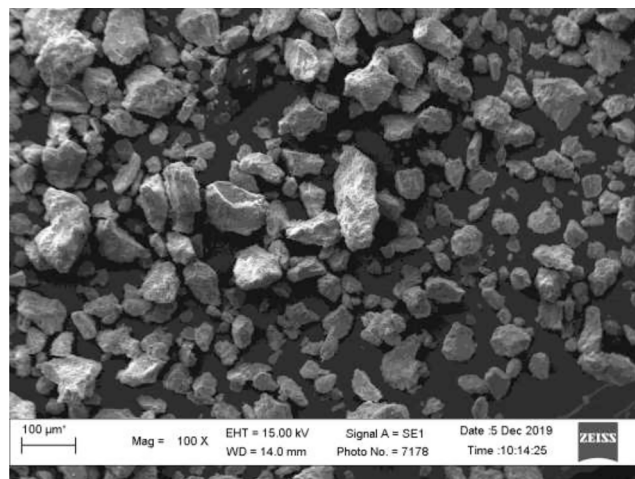

**Fig. 4.** SEM Images of clinoptilolite particles (ultrasonic power as 10.2 W (0.102 W/mL);  $\text{C}(\text{AgNO}_3) = 0.01 \text{ M}$ ; temperature as 25 °C).

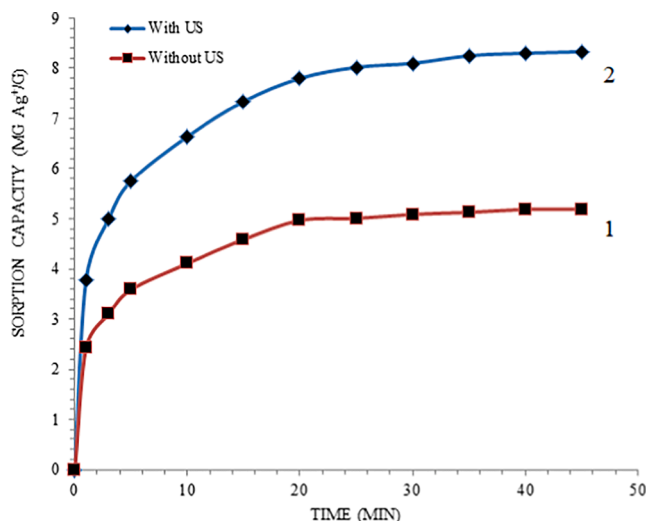

**Fig. 5.** The dependence of the content of  $\text{Ag}^+$  ions in clinoptilolite (2.5–3.0 mm) on time 1 – by mechanical mixing; 2 – under the action of ultrasound (ultrasonic power as 10.2 W (0.102 W/mL);  $\text{C}(\text{AgNO}_3) = 0.01 \text{ M}$ ; temperature as 25 °C).



The hypothesis is also confirmed by the fact both the sorption capacity and the value of the sorption rate constant of silver ions for clinoptilolite with an equivalent diameter of 2.75 mm were smaller than that seen for 1.25 mm. The sorption capacity of particles with a size of 2.75 mm, compared with particles of 1.25 mm under the action of ultrasound is less by 19%, and with mixing – less by as much as 50%. These data also confirm the increase in the efficiency of modification of clinoptilolite with the silver under the action of ultrasound.

Visual observation of the modification process also revealed an additional mechanism of enhanced sorption due to the use of ultrasound. At higher sizes of clinoptilolite particles over the range of 2.5 to 3.0 mm, the emission of small gas bubbles from zeolite particles under the action of ultrasonic radiation was observed (Fig. 6). The removal of air spaces from the pores allows higher sorption of the silver ions into the pores explaining the higher sorption capacity and also the observed turbulence explained the higher rate constants. In the presence of ultrasound, a slight turbidity of the solution was also seen due to the fact that under the action of ultrasonic vibrations, microparticles of montmorillonite are released from the particles of clinoptilolite.

Fig. 7 shows the change in the sorption capacity of the zeolite with dimensions of 0.063–0.1 mm (equivalent diameter 0.082 mm) under mechanical mixing and under the action of acoustic oscillations. As expected, an increase in dispersion (decrease in particle size) leads to an increase in the sorption capacity of clinoptilolite. The sorption capacity of clinoptilolite, modified under the action of ultrasonic radiation and mechanical mixing, is equal to 10.475 mg/g (for 0.082 mm) and 9.741 (1.25 mm), respectively. However, when using clinoptilolite of this fraction, the efficiency of ultrasound is less than that seen in the case of the fraction of 0.1–1.5 mm. The sorption capacity increased by only ~7.5%, which can be explained by the fact that with decreasing particle size of the zeolite (for the same mass), the contact area of the solution with solid particles increases sharply. Accordingly, the rate of sorption as a typical heterogeneous process increases significantly even without the action of ultrasound.

The rate constant of sorption of  $\text{Ag}^+$  ions by zeolite with an equivalent diameter of 0.082 mm under the action of ultrasonic radiation is equal to  $0.0504 \text{ s}^{-1}$ , which is 1.24 times higher than with stirring ( $0.0404 \text{ s}^{-1}$ ). The process of sorption of  $\text{Ag}^+$  ions under the action of ultrasound was observed to end after 15–17 min as demonstrated by no change in the potential of the Ag-selective electrode. With mechanical stirring, a constant potential value is reached within 40–45 min, again clearly demonstrating the intensification observed due to the use of ultrasound (about one third lower time for complete sorption).

The obtained results confirmed that the use of ultrasonic vibrations was not very effective for modifying highly dispersed clinoptilolite particles. For a slight increase in the sorption capacity, energy



Fig. 6. Isolation of air bubbles from clinoptilolite particles (2.5–3.0 mm) under the action of ultrasonic irradiation (ultrasonic power as 10.2 W (0.102 W/mL);  $\text{C}(\text{AgNO}_3) = 0.01 \text{ M}$ ; temperature as  $25^\circ\text{C}$ ).

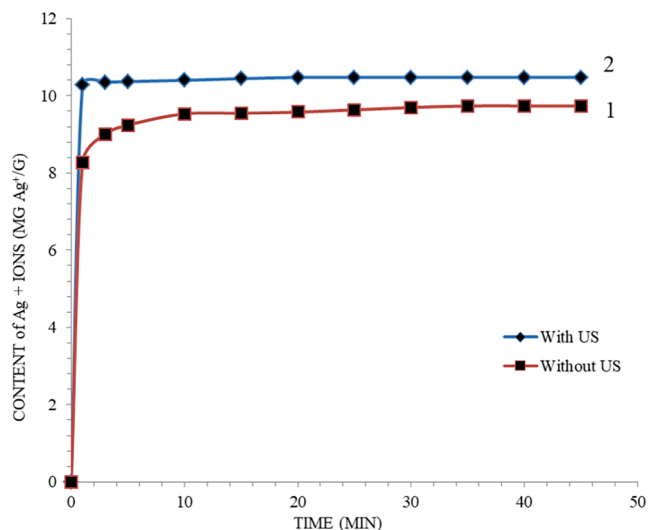

Fig. 7. The dependence of the content of  $\text{Ag}^+$  ions in clinoptilolite (0.063–0.1 mm) on time 1 – by mechanical mixing; 2 – under the action of ultrasound (ultrasonic power as 10.2 W (0.102 W/mL);  $\text{C}(\text{AgNO}_3) = 0.01 \text{ M}$ ; temperature as  $25^\circ\text{C}$ ).

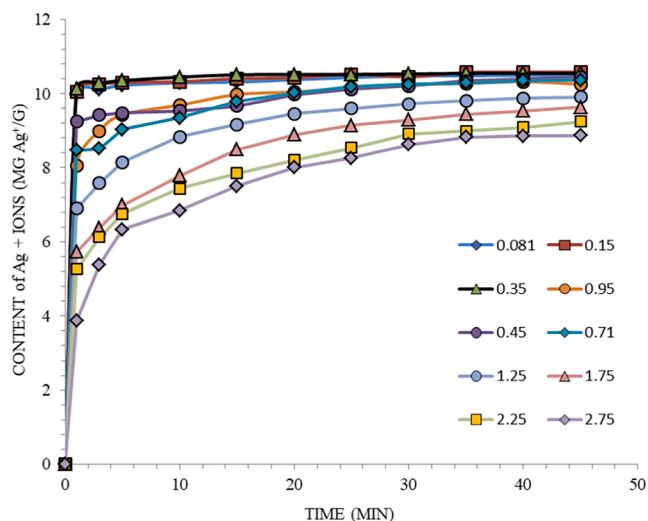

Fig. 8. The dependence of the content of  $\text{Ag}^+$  ions in clinoptilolite on time at  $25^\circ\text{C}$  and different equivalent diameter of clinoptilolite (ultrasonic power as 10.2 W (0.102 W/mL);  $\text{C}(\text{AgNO}_3) = 0.01 \text{ M}$ ; temperature as  $25^\circ\text{C}$ ).

consumption to obtain modified  $\text{Ag}^+$  ions clinoptilolite increases. Fig. 8 shows the dependence of the sorption capacity of different fractions of clinoptilolite on time. The regular decrease in the sorption capacity of clinoptilolite with an increase in the size of clinoptilolite (with the same mass in each experiment) is violated by increasing the equivalent particle diameter from 0.081 to 0.35 mm (Fig. 9). In this range, the sorption capacity increases slightly from 10.475 to 10.717 mg/g (Fig. 9), i.e. only 2.3%. These results were obtained during parallel experiments, so the increase in sorption capacity cannot be considered an experimental error. The very small effect of the sizes of highly dispersed clinoptilolite particles on the sorption capacity with respect to  $\text{Zn}^{2+}$  ions is also indicated in literature [36] and also for heavy metal ions [37]. Probably, the increase in the sorption capacity of clinoptilolite in this range of its sizes is due to a slight change in the structure of the mineral clinoptilolite under the action of mechanical load during grinding. With an increase in the equivalent particle diameter of clinoptilolite in the range from 0.35 to 2.75 mm, the sorption capacity, as expected again decreases (Fig. 9).

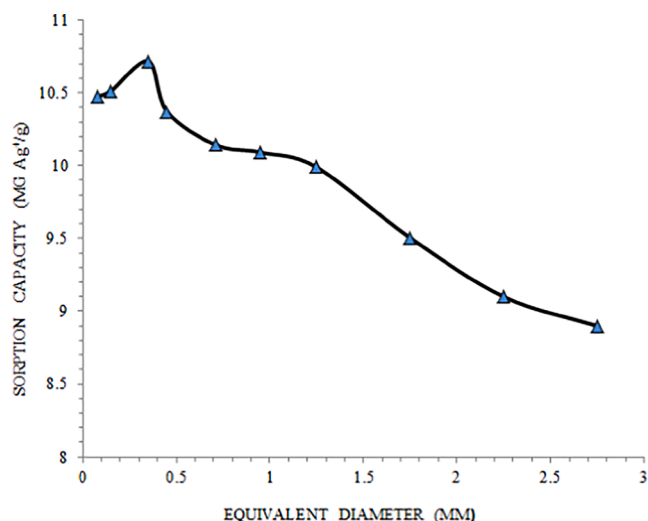

Fig. 9. The dependence of the sorption capacity of clinoptilolite on the equivalent diameter at a temperature of 25 °C (ultrasonic power as 10.2 W (0.102 W/mL);  $C(\text{AgNO}_3) = 0.01 \text{ M}$ ).

Sprynskyy et al. [38] established a similar pattern in the study of the sorption capacity of Transcarpathian clinoptilolite relative to ammonium ions. Lia et al. [39] also reported similar results for ammonia adsorption.

With increasing equivalent diameter from 0.081 to 0.35 mm, the sorption rate constant of silver ions, calculated by changing their concentration in solution, increased from  $5.05 \times 10^{-2}$  to  $7.61 \times 10^{-2} \text{ s}^{-1}$ . Subsequently, for values of equivalent diameter 0.45; 0.71; 0.95; 1.25; 1.75; 2.25 and 2.75 mm, the value of the sorption rate constant of  $\text{Ag}^+$  ions was observed to be equal to  $3.31 \times 10^{-2}$ ;  $1.89 \times 10^{-2}$ ;  $1.56 \times 10^{-2}$ ;  $1.22 \times 10^{-2}$ ;  $1.02 \times 10^{-2}$ ;  $0.86 \times 10^{-2}$  and  $0.79 \times 10^{-2} \text{ s}^{-1}$ , respectively (Fig. 10), showing a reducing trend very similar to the sorption capacity.

Based on the obtained results, overall, it can be stated that the process of modification of clinoptilolite by  $\text{Ag}^+$  ions occurs in the intradiffusion region. The use of ultrasonic radiation makes it possible to increase the sorption capacity of clinoptilolite by accelerating the diffusion of silver ions in the channels of clinoptilolite and the desorption of air from particles. It is also important to understand that observed effect is indeed dependent on the particle size as established by

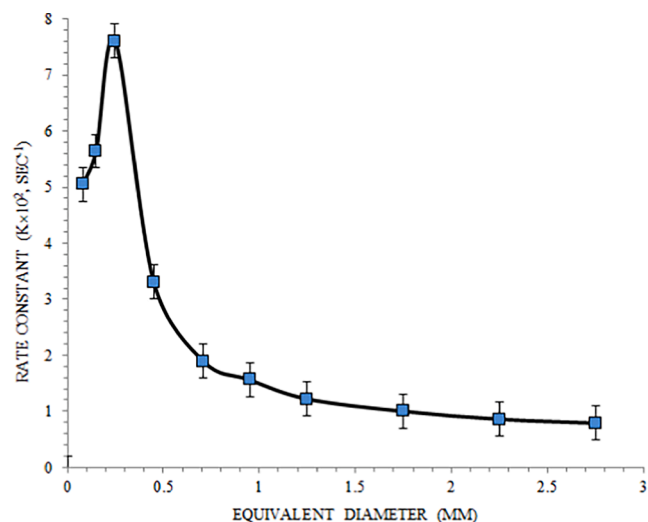

Fig. 10. Dependence of the sorption rate constant  $\text{Ag}^+$  on the equivalent particle diameter of clinoptilolite (25 °C) (ultrasonic power as 10.2 W (0.102 W/mL);  $C(\text{AgNO}_3) = 0.01 \text{ M}$ ).

a detailed study on the varying particle sizes.

### 3.2.2. Influence of temperature on sorption capacity of clinoptilolite

The study was performed over the temperature range 25–55 °C using different fractions of clinoptilolite as 0.063–0.01; 0.1–0.2; 0.3–0.4; 0.4–0.5; 0.63–0.8; 0.9–1.0; 1.0–1.5; 1.5–2.0; 2.0–2.5 and 2.5–3.0 mm (corresponding equivalent particle diameters were 0.081; 0.15; 0.35; 0.45; 0.71; 0.95; 1.25; 1.75; 2.25 and 2.75 mm). The trend for the variation in the sorption capacity of clinoptilolite for different fractions of clinoptilolite was similar to that observed as for 25 °C. For example, the dependence of the sorption capacity on time for different fractions of clinoptilolite at a temperature of 35 °C is shown in Fig. 11. As observed at 25 °C in the region of small values of equivalent diameter, there is a slight increase (but only by 0.8%) in the sorption capacity (Fig. 12). At the same time, the sorption rate increases slightly in this range of zeolite sizes, although the general trend is similar to that at lower temperatures with an increase in the equivalent diameter leading to a decrease in the sorption capacity (Fig. 12) and the sorption rate constant (Fig. 13).

The dependence of the sorption capacity of clinoptilolite fraction 0.9–1.0 mm (equivalent diameter 0.95 mm) on temperature is shown in Fig. 14. Using the sorption capacity of clinoptilolite (0.9–1.0 mm) at different temperature, the temperature coefficient ( $\gamma$ ) was calculated by the formula

$$\gamma = \frac{k_{T+10}}{k} \quad (3)$$

Here  $k_{T+10}$ ,  $k_T$  – rate constants of the sorption process at temperature  $T + 10$  and  $T$ , K.

From the ratio of rate constants at varying process temperature (K) as 308 and 298, 318 and 308, 323 and 318, the calculated temperature coefficient was equal to 1.47, 1.12 and 1.06 respectively. These values mean that temperature, especially with its increase, plays a smaller role in the sorption of silver ions. Chen et al. [40] also found a positive effect of temperature on the sorption of ammonium ions by natural zeolite. With increasing temperature from 25 to 50 °C, sorption capacity was reported to increase from 0.17 to 0.25 mEq/g. Payne and Abdel-Fattah [41] also reported an increase in the degree of extraction of  $\text{Pb}^{2+}$  ions from solutions by almost 22% with increasing temperature from 23 to 45 °C.

Since the value of the coefficient  $\gamma$  is less than 2, and with consideration of values of  $> 2$  being characteristic of the kinetic region of the process, it can be concluded that the process takes place in the diffusion

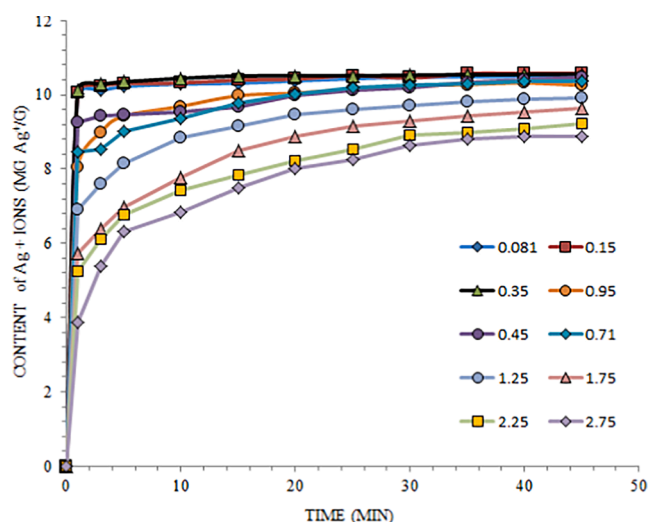

Fig. 11. The dependence of the content of  $\text{Ag}^+$  ions in clinoptilolite on time at 35 °C and different equivalent diameter of clinoptilolite (ultrasonic power as 10.2 W (0.102 W/mL);  $C(\text{AgNO}_3) = 0.01 \text{ M}$ ).

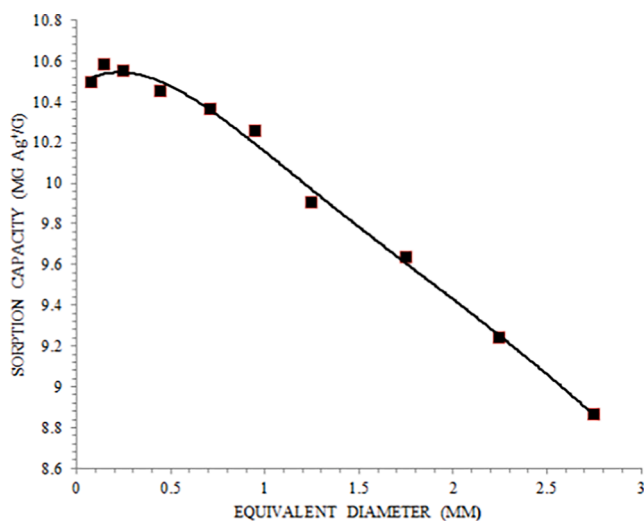

Fig. 12. Dependence of sorption capacity of clinoptilolite on equivalent diameter at 35 °C (ultrasonic power as 10.2 W (0.102 W/mL); C(AgNO<sub>3</sub>) = 0.01 M).

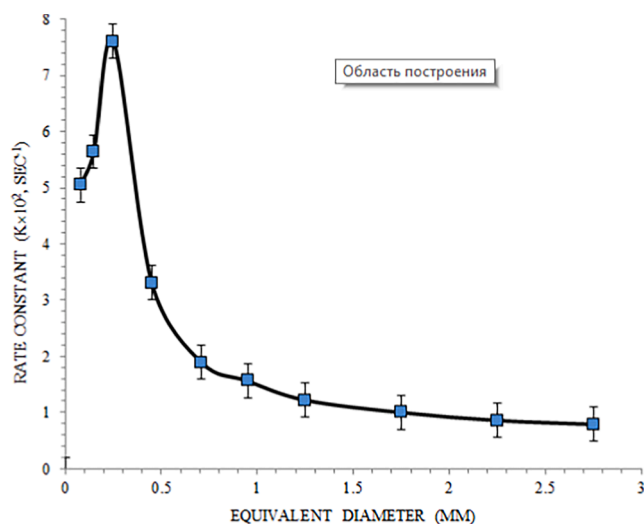

Fig. 13. Dependence of the sorption rate constant of Ag<sup>+</sup> on the equivalent particle diameter of clinoptilolite at 35 °C (ultrasonic power as 10.2 W (0.102 W/mL); C(AgNO<sub>3</sub>) = 0.01 M).

region. Erten-Kaya et al. [35] also concluded that diffusion has a dominant effect on the process in the case of ion exchange. Overall, based on the results of the dependence of the rate constant on the temperature for different equivalent particle size of clinoptilolite, it can be argued that the process of sorption of silver ions occurs in the intradiffusion region.

### 3.2.3. Influence of ultrasonic power on sorption capacity of clinoptilolite

The study was performed with a fraction of clinoptilolite 0.9–1.0 mm over the power range of the ultrasound emitter as 8.0–12.5 W. The dependence of the sorption capacity of clinoptilolite on the power of the ultrasonic emitter is not monotonous, as might be expected. With an increase in radiation power from 8.0 to 10.2 W, the sorption capacity decreases slightly. At a power of 8.0, 9.2 and 10.2 W sorption capacity was equal to 10.489, 10.298 and 10.091 mg/g respectively with a change of only 3.8%. Further increase in power to 11.2 and 12.5 W resulted in increase in the sorption capacity by around 3.4% with actual values as 10.377 and 10.433 mg/g, respectively. It can be thus said that the power of the ultrasonic emitter in this range has little effect on the

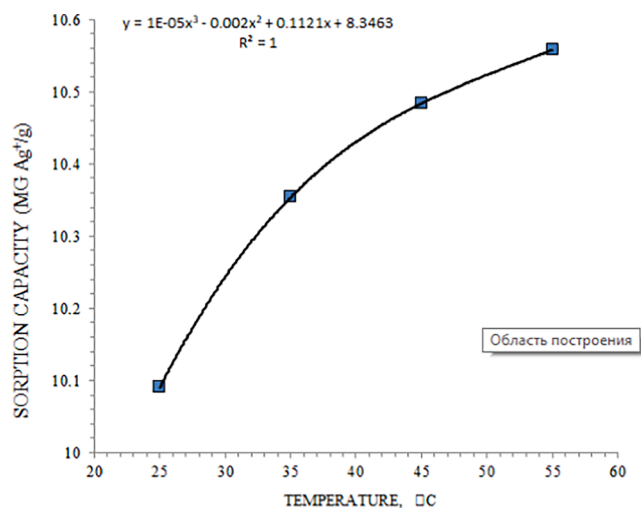

Fig. 14. The dependence of the sorption capacity of clinoptilolite (0.9–1.0 mm) on temperature (ultrasonic power as 10.2 W (0.102 W/mL); C(AgNO<sub>3</sub>) = 0.01 M).

sorption capacity of clinoptilolite. Based on these data, we can assume that to achieve the sorption capacity of clinoptilolite of about 10 mg/g (at a concentration of AgNO<sub>3</sub> of 0.01 M) it is sufficient to carry out the process at a power of 8.0 W. The specific energy consumption (E, J/mg × g) for the sorption of silver ions was determined by the equation

$$E = \frac{W \times \tau}{S} \quad (4)$$

where W – power of ultrasonic radiation, W (J/s);

$\tau$  – duration of the sorption process, sec;

S – sorption capacity of clinoptilolite, mgAg<sup>+</sup>/g.

At a radiation power of 8.0; 9.2; 10.2; 11.2 and 12.5 W, the specific energy consumption for the sorption of silver ions was observed as 2.06; 2.41; 2.73; 2.91 and 3.23 kJ/mgAg<sup>+</sup> × g respectively. Thus, a 1.56-fold increase in power leads to almost the same increase in specific energy consumption as 1.57 times. This confirms the conclusion that in the specified power range of the ultrasound emitter modification of clinoptilolite with silver ions should be carried out at the minimum power (in the range of possible power change studied in the current work) of the ultrasonic emitter as 8.0 W. It is important to note that the effect seen in the work might be attributed to lower variation in the power based on the available reactor configuration and may not be generalized.

### 3.2.4. Effect of AgNO<sub>3</sub> solution concentration on the sorption capacity of clinoptilolite

Studies showed that under the action of ultrasonic irradiation at a concentration of AgNO<sub>3</sub> solution of 0.01 M, sorption capacity of clinoptilolite increased, especially for the larger particle sizes of clinoptilolite. The maximum content of Ag<sup>+</sup> ions was only slightly greater than 10 mg/g and the degree of sorption of Ag<sup>+</sup> ions ( $\alpha$ , %) reached even 99%, as determined by the equation

$$\alpha = \frac{(C_0 - C) \times 100}{C_0} \quad (5)$$

where C<sub>0</sub>, C – initial and final (equilibrium) concentration of silver ions in solution, mg/L.

Almost complete sorption of Ag<sup>+</sup> ions from the solution was achieved and, accordingly, the sorption capacity practically reached its maximum values (under the conditions of research). Obviously, the need to provide a higher content of Ag<sup>+</sup> ions so as to evaluate the maximum sorption capacity prompted the use solutions of silver nitrate with a higher concentration. Therefore, the effect of AgNO<sub>3</sub> concentration on the sorption

capacity of clinoptilolite was investigated using different solutions of  $\text{AgNO}_3$  with a concentration of 0.01; 0.025; 0.05; 0.075 and 0.1 M.

The change in the sorption capacity of clinoptilolite for different concentrations of  $\text{AgNO}_3$  is shown in Fig. 15. The analysis of the trends of the change in sorption capacity over time at different concentrations of  $\text{AgNO}_3$  indicates that with increasing concentration, sorption capacity increases attributed to the fact that the depth of penetration of  $\text{Ag}^+$  ions into the internal volume of the clinoptilolite particle increases with an increase in concentration. It is obvious that with increasing the concentration of  $\text{AgNO}_3$  solution, the driving force of the diffusion process of  $\text{Ag}^+$  ions increases leading to higher penetration. For example, at a concentration of 0.01 M, the largest increase in sorption capacity (about 60% of the maximum under these conditions) is observed during the first minute, while for the next about 40 min it is equal to about 40%. As the concentration of  $\text{AgNO}_3$  increases, the saturation of clinoptilolite with  $\text{Ag}^+$  ions to reach the maximum value of sorption capacity for certain conditions is stretched in time. This suggests that the main role in the modification of clinoptilolite by silver ions is played by diffusion phenomena.

For the fraction of clinoptilolite as 0.9–1.0 mm, the values of the equilibrium content of  $\text{Ag}^+$  ions reached were 10.091; 25.003; 39.551; 45.703 and 50.046 mg/g (Fig. 16) at different concentrations of the  $\text{AgNO}_3$  solution. Increasing the concentration of  $\text{AgNO}_3$  by 10 times provides an increase in the sorption capacity of clinoptilolite by  $\text{Ag}^+$  ions by 5 times (from ~10 to ~50 mg/g). It is also important to note that use of ultrasound has enhanced the sorption capacity at all the studied concentrations, as compared to the control studies with only mechanical mixing. The obtained results show that the use of ultrasound makes it possible to provide a high content of silver ions in clinoptilolite, which increases its antimicrobial action and expands its scope.

#### 4. Determination of metal cations in modified clinoptilolite

The content of cations  $\text{Ag}^+$ ,  $\text{Na}^+$ ,  $\text{K}^+$ ,  $\text{Mg}^{2+}$  and  $\text{Ca}^{2+}$  in clinoptilolite after modification with  $\text{AgNO}_3$  solution was determined by EDX method (Fig. 17). The clinoptilolite sample was pre-treated in distilled water under ultrasound for 45 min. This was done in order to use acoustic oscillations to remove montmorillonite from the particles of clinoptilolite. Removal of montmorillonite particles occurs during the modification of clinoptilolite with  $\text{AgNO}_3$  solution, as evidenced by the turbidity of the solution (Fig. 6). The content of exchange cations ( $\text{Na}^+$ ,  $\text{K}^+$ ,  $\text{Ca}^{2+}$ ,  $\text{Mg}^{2+}$ ) in the clinoptilolite sample before modification with a solution of

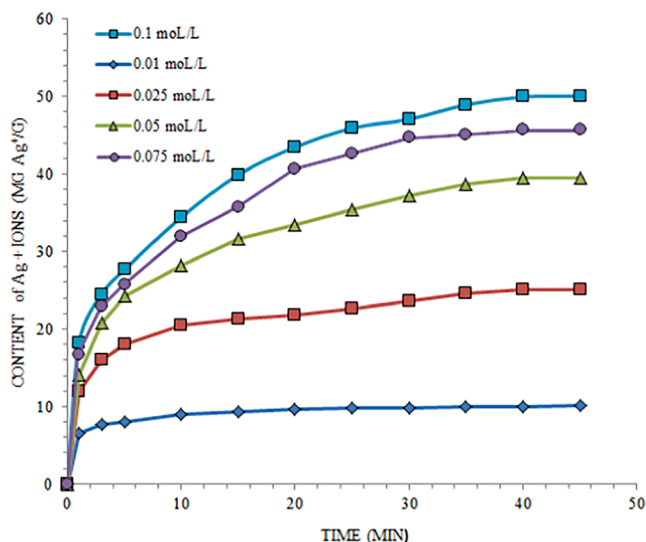

Fig. 15. The dependence of the content of  $\text{Ag}^+$  ions in clinoptilolite (1.0–1.5 mm) on time and concentration of  $\text{AgNO}_3$  (ultrasonic power as 10.2 W (0.102 W/mL); temperature as 25 °C).

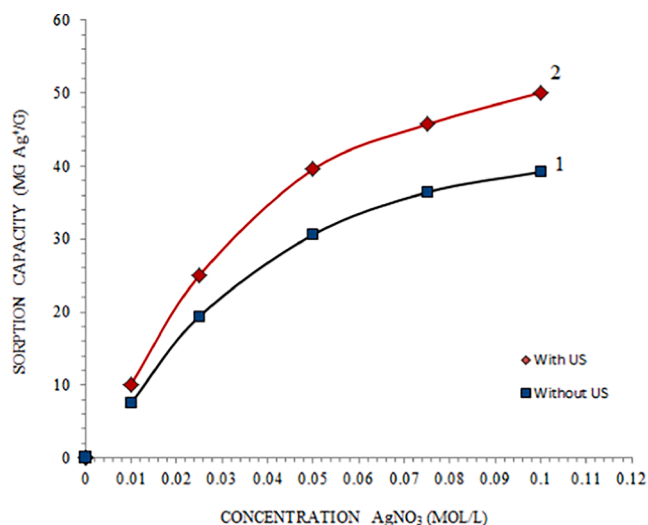

Fig. 16. The dependence of the sorption capacity of clinoptilolite on the concentration of  $\text{AgNO}_3$  (clinoptilolite fraction of 0.9–1.0 mm; temperature as 25 °C, power of ultrasonic irradiation as 10.2 W).

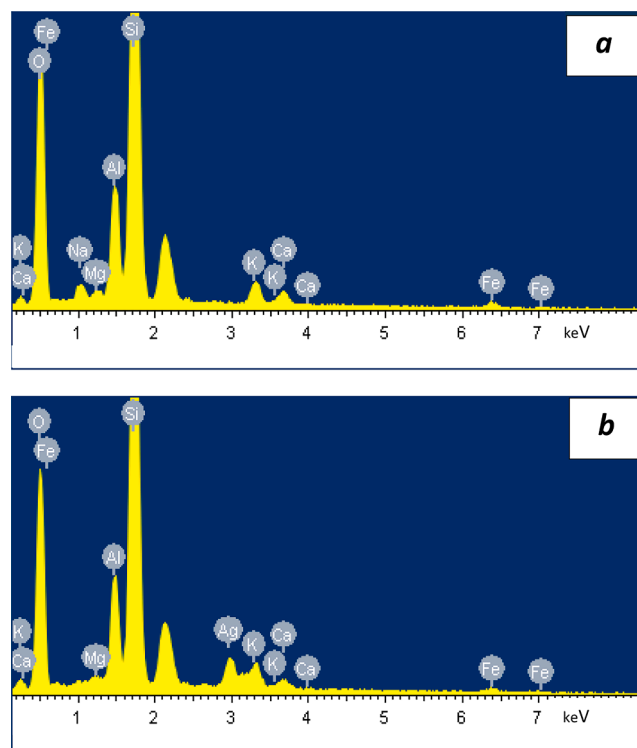

Fig. 17. Typical EDX analysis of clinoptilolite samples: a - unmodified; b - modified with silver ions.

0.01 N  $\text{AgNO}_3$  was (mass % (mEq/g)):  $\text{Na}^+$  – 1.32 (0.574);  $\text{K}^+$  – 2.81 (0.720);  $\text{Ca}^{2+}$  – 1.52 (0.760) and  $\text{Mg}^{2+}$  – 0.51 (0.425). The integral content of exchange cations in this clinoptilolite is 2.479 mEq/g. After modification of clinoptilolite under the action of ultrasound, the content of cations in clinoptilolite was (mass % (mEq/g)):  $\text{Ag}^+$  – 7.92 (0.733);  $\text{Na}^+$  – 0.0 (0.000);  $\text{K}^+$  – 2.53 (0.649);  $\text{Ca}^{2+}$  – 1.49 (0.745) and  $\text{Mg}^{2+}$  – 0.45 (0.375). The obtained results indicate that ion exchange between clinoptilolite sodium cations and  $\text{Ag}^+$  ions predominates during the modification. The total content of exchangeable cation equivalents is equal to 1.769 mEq/g which is 0.710 mEq/g less than in the original clinoptilolite. The content of  $\text{Ag}^+$  ion equivalents is greater than the



decrease in the content of exchange cations ( $0.733 > 0.710$ ). Therefore, it can be argued that in this sample of zeolite, silver ions are absorbed mainly due to ion exchange (96.9%), and partly due to sorption of argentum nitrate (3.1%).

Cationic composition of a sample of clinoptilolite modified by mechanical stirring without the action of ultrasonic vibrations was also quantified and the obtained results were in terms of mass % (mEq/g) as follows:  $\text{Ag}^+ - 6.79$  (0.629);  $\text{Na}^+ - 0.45$  (0.196);  $\text{K}^+ - 2.58$  (0.662);  $\text{Ca}^{2+} - 1.41$  (0.705) and  $\text{Mg}^{2+} - 0.46$  (0.383). The content of exchange cations is 1.946 mEq/g, which means that decrease in the content of exchange cations is equal to 0.533 mEq/g. Without the action of ultrasound radiation, silver ions are absorbed due to ion exchange to a lesser extent than under the action of ultrasound (84.7%). The obtained results confirm the hypothesis that ultrasound makes it possible to increase the sorption capacity of clinoptilolite by accelerating the diffusion of  $\text{Ag}^+$  ions and desorption of air from the micropores of clinoptilolite.

## 5. Conclusions

The current work allowed to establish the effectiveness of ultrasound in enhancing the sorption capacity of natural clinoptilolite for the silver ions. Studies clearly depicted that at different temperatures with increasing equivalent particle diameter of clinoptilolite from 0.081 mm to 0.35 mm, the sorption capacity of clinoptilolite increases slightly. Increasing the equivalent diameter to 2.75 mm leads to a natural monotonic decrease in the sorption capacity. A similar pattern is observed for the dependence of the sorption rate constant on the size of clinoptilolite. Visual observations confirmed the release of air bubbles from clinoptilolite particles under the action of ultrasound, which promotes the sorption of silver ions. It was also clearly demonstrated that as the equivalent particle diameter of clinoptilolite decreases, the effectiveness of ultrasound decreases. For example, for 0.081 mm, the increase in sorption capacity is about 7.5%. For clinoptilolite of particle size 2.75 mm, increase in sorption capacity under the action of

ultrasound is 56%. The calculated values of the temperature coefficient of the sorption process in the temperature range 25–55 °C (298–328 K) equal to 1.47; 1.12 and 1.06 clearly meant that the process takes place dominantly in the diffusion region. Increasing the power of ultrasonic irradiation did not increase the sorption capacity of clinoptilolite. Increasing the concentration of  $\text{AgNO}_3$  solution, which modified clinoptilolite, allowed to increase sorption capacity of clinoptilolite from ~10 to ~50 mg  $\text{Ag}^+$ /g. The EDX analysis showed that the role of ion exchange in the modification of clinoptilolite increases under the action of ultrasound. Overall it was clearly demonstrated that the use of ultrasonic vibrations allows to significantly increase the sorption capacity of clinoptilolite leading to higher activity based on the silver content.

## CRedit authorship contribution statement

**Z. Znak:** Supervision, Project administration, Funding acquisition. **O. Zin:** Conceptualization, Methodology, Investigation. **A. Mashteler:** Investigation, Methodology. **S. Korniy:** Methodology, Investigation. **Yu. Sukhatskiy:** Supervision. **Parag R. Gogate:** Funding acquisition. **R. Mnykh:** Supervision. **Pooja Thanekar:** Investigation.

## Declaration of Competing Interest

The authors declare that they have no known competing financial interests or personal relationships that could have appeared to influence the work reported in this paper.

## Acknowledgement

Authors acknowledge the funding of Ministry of Science and Education of Ukraine and Department of Science and Technology, India for the Indo-Ukraine joint project (M-39/2020, INT/UKR/P-23/2018) with Institute of Chemical Technology, Mumbai, India.

## Appendix I

Sample calculation for the sorption capacity of clinoptilolite.

Sorption capacity of clinoptilolite, S is

$$S = \frac{((C_0 - C) \times V - C_w \times V_w) \times M_{\text{Ag}}}{m}$$

where,  $C_0$  = initial concentration of  $\text{Ag}^+$  ions in solution as  $1.0 \times 10^{-2}$  M;  $C$  = actual concentration  $\text{Ag}^+$  ions at a certain point in time as  $3.01 \times 10^{-4}$  M;  $C_w$  = concentration of  $\text{Ag}^+$  ions in washing water as  $4.1 \times 10^{-5}$  M;  $V$  = volume of modification solution as 0.1 L;  $V_w$  = volume of wash water as 0.25 L;  $M_{\text{Ag}}$  = molar mass of silver as 108 g/mol;  $m$  = mass of clinoptilolite as 10.01 g.

$$\begin{aligned} \text{sorption capacity} &= \frac{((1.0 \times 10^{-2} - 3.01 \times 10^{-4}) \times 0.1 - 4.1 \times 10^{-5} \times 0.25) \times 108}{10.01} = \\ &= 0.0104 \text{gAg}^+/\text{g} \end{aligned}$$

Sample calculation of sorption rate constant of  $\text{Ag}^+$  ions

Sorption rate constant of  $\text{Ag}^+$  ions is give by the following equation:

$$k = \frac{1}{\tau} \ln \frac{C_0}{C}$$

where,  $\tau$  = time as 60 s;  $C_0$  = initial concentration of silver ions in solution as 0.01 mol/L;  $C$  = current concentration of silver ions in solution as 0.00482 M.

$$\text{sorption rate constant} = \frac{1}{60} \ln \frac{0.01}{0.0049} = 0.0506$$

Sample calculation of temperature coefficient

Temperature coefficient is given as follows:

$$\gamma = \frac{k_{T+10}}{k}$$

where  $k_{T+10}$  = sorption rate constant at temperature of 308 K as  $0.0229 \text{ s}^{-1}$ ;  $k_T$  = sorption rate constant at temperature 298 K as  $0.0156 \text{ s}^{-1}$ .  
 The temperature coefficient =  $0.0229 / 0.0156 = 1.47$ .

## References

- M.A. Scott, A.C. Kathleen, K.D. Prabir, Handbook of Zeolite Science and Technology, Marcel Dekker Inc., USA, 2003, p. 1170.
- S. Kulprathipanja, Zeolites in Industrial Separation And Catalysis, WILEY-VCH Verlag GmbH & Co KGaA, Weinheim, 2010, p. 593. DOI:10.1002/9783527629565.
- P. Kowalczyk, M. Sprynsky, A.P. Terzyk, M. Lebedynets, J. Namiesnik, B. Buszewski, Porous structure of natural and modified clinoptilolites, J. Colloid Interface Sci. 297 (2006) 77–85, <https://doi.org/10.1016/j.jcis.2005.10.045>.
- U. Wingenfelder, C. Hansen, G. Furrer, R. Schulin, Removal of heavy metals from mine waters by natural zeolites, Environ. Sci. Technol. 39 (12) (2005) 4606–4613, <https://doi.org/10.1021/es048482s>.
- S.S. AL-Oud, A.M. Ghoneim, M.A. Nadeem, S. Al Harbi, Application efficiency of Clinoptilolite natural zeolite for  $\text{Pb}^{2+}$  and  $\text{Cu}^{2+}$  removal from Wastewater, Wulfenia 22 (2) (2015) 317–332.
- N. Elboughdiri, The use of natural zeolite to remove heavy metals Cu (II), Pb (II) and Cd (II), from industrial wastewater, Cogent Engineering 7 (2020) 1782623, <https://doi.org/10.1080/23311916.2020.1782623>.
- M. Sprynsky, B. Buszewski, A.P. Terzyk, J. Namiesnik, Study of the selection mechanism of heavy metal ( $\text{Pb}^{2+}$ ,  $\text{Cu}^{2+}$ ,  $\text{Ni}^{2+}$  and  $\text{Cd}^{2+}$ ) adsorption on clinoptilolite, J. Colloid Interface Sci. 304 (2006) 21–28, <https://doi.org/10.1016/j.jcis.2006.07.068>.
- H. Shirzadi, A. Nezamzadeh-Ejhieh, An efficient modified zeolite for simultaneous removal of Pb(II) and Hg(II) from aqueous solution, J. Mol. Liq. 230 (2017) 221–229.
- M. Nasiri-Ardali, A. Nezamzadeh-Ejhieh, A comprehensive study on the kinetics and thermodynamic aspects of batch and column removal of Pb(II) by the clinoptilolite–glycine adsorbent, Mater. Chem. Phys. 240 (2020), 122142, <https://doi.org/10.1016/j.matchemphys.2019.122142>.
- B. Bogdanov, D. Georgiev, K. Angelova, K. Yaneva, Natural zeolites: clinoptilolite review, in: International Science Conference, Stara Zagora, Bulgaria. International Science conference “Economics and Society development on the Base of Knowledge”, 4th - 5th June, Volume IV, Natural & Mathematical science, Stara Zagora, Bulgaria, 2009, pp. 6–11.
- H. Valpotić, D. Gračner, R. Turk, D. Durčić, S. Vince, I. Folnožić, M. Ljokić, I. Žura, Ž.L. Bedrica, N. Mačević, I. Getz, T. Dobranić, M. Samardžija, Zeolite clinoptilolite nanoporous feed additive for animals of veterinary importance: potentials and limitations, Period. Biol. 119 (3) (2017) 159–172, <https://doi.org/10.18054/pb.v119i3.5434>.
- Yu.I. Tarasevich, V.V. Goncharuk, V.E. Polyakov, Efficient technology for the removal of iron and manganese ions from artesian water using clinoptilolite, J. Ind. and Eng. Chem 18 (2012) 1438–1440.
- Application of natural zeolites in medicine and cosmetology – ZEOMEDCOS. Proceedings. SWB. Baku-London, (2010) 164.
- A. Nezamzadeh-Ejhieh, S. Tavakoli-Ghinani, Effect of a nano-sized natural clinoptilolite modified by the hexadecyltrimethyl ammonium surfactant on cephalexin drug delivery, C. R. Chim. 17 (1) (2014) 49–61.
- S.K. Pavelic, J.S. Medica, D. Gumbarevic, A. Filosevic, N. Przulj, K. Pavelic, Critical Review on Zeolite Clinoptilolite Safety and Medical Applications *in vivo*, Front. Pharm. 9 (2018) 1350, <https://doi.org/10.3389/fphar.2018.01350>.
- A. Mastinu, A. Kumar, G. Maccarinelli, S.A. Bonini, M. Premoli, F. Aria, A. Gianocelli, M. Memo, Zeolite clinoptilolite: therapeutic virtues of an ancient mineral. Review, Molecules 24 (2019) 1517, <https://doi.org/10.3390/molecules24081517>.
- T. Nakane, H. Gomyo, I. Sasaki, Y. Kimoto, N. Hanzawa, Y. Teshima, T. Namba, New antiaxillary odour deodorant made with antimicrobial Ag-zeolite (silver-exchanged zeolite), Int. J. Cosmet. Sci. 28 (4) (2006) 299–309, <https://doi.org/10.1111/j.1467-2494.2006.00322.x>.
- K. Shameli, M.B. Ahmad, M. Zargar, W.M.Z.W. Yunus, N.A. Ibrahim, Fabrication of silver nanoparticles doped in the zeolite framework and antibacterial activity, Int. J. Nanomed. 6 (2011) 331–341, <https://doi.org/10.2147/IJN.S16964>.
- F. Mirzajani, A. Ghassempour, A. Aliahmadi, M. AliEsmaili, Antibacterial effect of silver nanoparticles on *Staphylococcus aureus*, Res. Microbiol. 162 (5) (2011) 542–549, <https://doi.org/10.1016/j.resmic.2011.04.009>.
- M.A. Radzig, V.A. Nadtochenko, O.A. Koksharova, J. Kiwi, V.A. Lipasova, I. A. Khmel, Antibacterial effects of silver nanoparticles on gram-negative bacteria: Influence on the growth and biofilms formation, mechanisms of action, Colloids Surf. B 102 (1) (2013) 300–306, <https://doi.org/10.1016/j.colsurfb.2012.07.039>.
- M. Rai, A. Yadav, A. Gade, Silver nanoparticles as a new generation of antimicrobials, Biotechnol. Adv. 27 (2009) 76–83, <https://doi.org/10.1016/j.biotechadv.2008.09.002>.
- M.N.B. Momba, G. Offringa, G. Nameni, B. Brouckaert, Nanotechnology-based clay filter pot to purify water in rural homes, Research Report No KV 244/10, Water Research Commission, Pretoria, South Africa, 2010.
- B. Concepción-Rosabal, G. Rodríguez-Fuentes, N. Bogdanchikova, P. Bosch, M. Avalos, V.H. Lara, Comparative study of natural and synthetic clinoptilolites containing silver in different states, Microporous Mesoporous Mater. 86 (1–3) (2005) 249–255, <https://doi.org/10.1016/j.micromeso.2005.07.027>.
- M.G. Hwang, H. Katayama, S. Ohgaki, Inactivation of Legionella pneumophila and Pseudomonas aeruginosa: Evaluation of the bactericidal ability of silver cations, Water Res. 41 (18) (2007) 4097–4104, <https://doi.org/10.1016/j.watres.2007.05.052>.
- Q.L. Feng, J. Wu, G.Q. Chen, F.Z. Cui, T.N. Kim, J.O. Kim, A mechanistic study of the antibacterial effect of silver ions on Escherichia coli and Staphylococcus aureus, J. Biomed. Mater. 52 (4) (2000) 662–668, [https://doi.org/10.1002/1097-4636\(20001215\)52:4<662::AID-JBM10>3.0.CO;2-3](https://doi.org/10.1002/1097-4636(20001215)52:4<662::AID-JBM10>3.0.CO;2-3).
- L. Petrik, R. Missengue, O. Fatoba, M. Tuffin, J. Sachs, Silver/zeolite nano composite-based clay filters for water disinfection, in: Report to the Water Research Commission. WRC Report No. KV 297/12. Gezina, 2012, p. 67.
- Y. Lu, H. Liu, Z. Wang, S. Liu, L. Hao, Y. Sang, D. Liu, J. Wang, R. Boughton, Silver nanoparticle-decorated porous ceramic composite for water treatment, J. Membr. Sci. 331 (2009) 50–56.
- I. De la Rosa-Gómez, M.T. Olguín, D. Alcántara, Antibacterial behavior of silver-modified clinoptilolite–heulandite rich tuff on coliform microorganisms from wastewater, J. Environ. Manage. 88 (4) (2008) 853–863, <https://doi.org/10.1016/j.jenvman.2008.04.013>.
- I. De la Rosa-Gómez, M.-T. Olguín, D. Alcántara, Silver-Modified Mexican Clinoptilolite-Rich Tuffs With Various Particle Sizes as Antimicrobial Agents Against Escherichia coli, J. Mex. Chem. Soc. 54 (3) (2010) 139–142.
- A.S. Mashtaler, Z.O. Znak, O.I. Zin, Yu.V. Sukhatskiy, M.A. Pyrig, Influence of acoustic radiation of ultrasonic range on modification of natural clinoptilolite by ions of argentum, Chem. Technol. Appl. Subst. 3 (1) (2020) 33–38, <https://doi.org/10.23939/ctas2020.01.033>.
- S. Guilane, O. Hamdaoui, Regeneration of exhausted granular activated carbon by low frequency ultrasound in batch reactor, Desalin. Water Treat. 57 (34) (2016) 15826–15834, <https://doi.org/10.1080/19443994.2015.1077350>.
- O.N. Khohlova, Thermodynamic description of superequivalent sorption by ion exchangers: Theoretical background, Russ. J. Phys. Chem. 88 (8) (2014) 1423–1426, <https://doi.org/10.1134/S0036024414080123>.
- P. Thanekar, P. Gogate, Z. Znak, Y. Sukhatskiy, R. Mnykh, Degradation of benzene present in wastewater using hydrodynamic cavitation in combination with air, Ultrason. Sonochem. 70 (2021), 105296.
- Z. Danková, A. Mockovčiaková, S. Dolinská, Influence of ultrasound irradiation on cadmium cations adsorption by montmorillonite, Desalin. Water Treat. 52 (2014) 5462–5469.
- Y. Erten-Kaya, F. Kakiçoglu-Ozkan, Effect of ultrasound on the kinetics of cation exchange in NaX zeolite, Ultrason. Sonochem. 19 (3) (2012) 701–706.
- S.K. Ouki, C. Cheeseman, R. Perry, Effects of conditioning and treatment of chabazite and clinoptilolite prior to lead and cadmium removal, Environ. Sci. Technol. 27 (1993) 1108–1116.
- U. Wingenfelder, C. Hansen, G. Furrer, R. Schulin, Removal of heavy metals from mine waters by natural zeolites, Environ. Sci. Technol. 39 (2005) 4606–4613.
- M. Sprynsky, M. Lebedynets, A.P. Terzyk, P. Kowalczyk, J. Namiesnik, B. Buszewski, Ammonium sorption from aqueous solutions by the natural zeolite Transcarpathian clinoptilolite studied under dynamic conditions, J. Colloid Interface Sci. 284 (2005) 408–415.
- X. Lia, C. Lina, Y. Wanga, M. Zhaoa, Y. Houa, Clinoptilolite Adsorption Capability of Ammonia in Pig Farm, Procedia Environmental Sciences, International Society for Environmental Information Sciences 2010 Annual Conference (ISEIS), 2 (2010) 1598–1612.
- H.-F. Chen, Y.-J. Lin, B.-H. Chen, I. Yoshiyuki, S.Y.-H. Liou, R.-T. Huang, A further investigation of  $\text{NH}_4^+$  removal mechanisms by using natural and synthetic zeolites in different concentrations and temperatures, Minerals 8 (2018) 499, <https://doi.org/10.3390/min8110499>.
- K.B. Payne, T. Abdel-Fattah, Adsorption of divalent lead ions by zeolites and activated carbon: effects of pH, temperature, and ionic strength, J. Environ. Sci. Health Part A—Toxic/Hazard. Subst. Environ. Eng. A39 (9) (2004) 2275–2291, <https://doi.org/10.1081/ESE-200026265>.