

Promoter considerations in the design of lentiviral vectors for use in treating lysosomal storage diseases

Estera Rintz,^{1,2} Takashi Higuchi,³ Hiroshi Kobayashi,³ Deni S. Galileo,⁴ Grzegorz Wegrzyn,¹ and Shunji Tomatsu^{2,4,5,6}

¹Department of Molecular Biology, Faculty of Biology, University of Gdansk, Wita Stwosza, 59, 80-308 Gdansk, Poland; ²Nemours/Alfred I. duPont Hospital for Children, 1600 Rockland Road, Wilmington, DE 19803, USA; ³Division of Gene Therapy, Research Center for Medical Sciences, The Jikei University School of Medicine, 3 Chome-25-8 Nishishinbashi, Minato City, Tokyo 105-8461, Japan; ⁴Department of Biological Sciences, University of Delaware, 118 Wolf Hall, Newark, DE 19716, USA; ⁵Department of Pediatrics, Gifu University, Gifu, Yanagido 501-1193, Japan; ⁶Department of Pediatrics, Thomas Jefferson University, 901 Walnut Street, Philadelphia, PA 19107, USA

More than 50 lysosomal storage diseases (LSDs) are associated with lysosomal dysfunctions with the frequency of 1:5,000 live births. As a result of missing enzyme activity, the lysosome dysfunction accumulates undegraded or partially degraded molecules, affecting the entire body. Most of them are life-threatening diseases where patients could die within the first or second decade of life. Approximately 20 LSDs have the approved treatments, which do not provide the cure for the disorder. Therefore, the delivery of missing genes through gene therapy is a promising approach for LSDs. Over the years, *ex vivo* lentiviral-mediated gene therapy for LSDs has been approached using different strategies. Several clinical trials for LSDs are under investigation. *Ex vivo* lentiviral-mediated gene therapy needs optimization in dose, time of delivery, and promoter-driven expression. Choosing suitable promoters seems to be one of the important factors for the effective expression of the dysfunctional enzyme. This review summarizes the research on therapy for LSDs that has used different lentiviral vectors, emphasizing gene promoters.

INTRODUCTION

Lysosomal storage diseases (LSDs) are a group of inherited metabolic disorders caused by the deficiency of lysosomal enzyme activity (Table 1). As a result, the lysosome dysfunction accumulates undegraded or partially degraded molecules, affecting the entire body. The clinical outcome of patients in most LSDs affects neurological and peripheral organs.¹ Despite many attempts, most LSDs cannot be effectively treated to date.² Therapies for LSDs are based on the cross-correction mechanism discovered more than 50 years ago. This mechanism is based on the ability of the soluble enzyme to recognize the mannose-6-phosphate receptor owing to the ligand present.^{3–5} In conventional enzyme replacement therapy (ERT), the recombinant enzyme could be delivered intravenously, but owing to enzyme inability to cross the blood–brain barrier (BBB), different administration routes have been tested via intrathecal or intracerebroventricular administration. Another approach is to modify enzymes to penetrate

the BBB via transferrin receptor.^{6,7} Although ERT is an available treatment for some LSDs, there are several limitations compared with *ex vivo* lentiviral-mediated gene therapy: (1) its half-life is short, (2) the cost is expensive, (3) it has a limited impact on avascular tissues organ, and (4) weekly infusions are required for life.⁸

Potential therapy for LSDs is hematopoietic stem cell transplantation (HSCT), where the cells from a healthy donor repopulate in the recipient patient and secrete enzymes within the periphery of the organism. During the HSCT process, the monocytes can cross the BBB, differentiate into microglial cells within the brain, and mediate the cross-correction.⁹ “HSCT could protect or ameliorate CNS damage in some LSDs if it is conducted at an early stage; however, it still does not correct CNS impairment in other diseases.” There is also a risk of transplant rejection and immune reaction (graft-vs-host disease) to transplanted cells.^{10,11}

In recent years, gene therapy has attracted more attention owing to its potential use in single-gene diseases, including LSDs. Promising viral gene therapy results on animal models have been observed with regards to safety and efficacy.¹² At present, the most promising vectors for replacing missing genes are either adeno-associated viruses (AAV) or lentiviruses (LV). Both of these viruses have advantages and drawbacks. The main disadvantage of AAV use is the low size capacity of the transgene (approximately 4.5 kb). Another disadvantage is the requirement for a proper serotype that recognizes target cells and tissues and does not trigger an immune response.¹³ Some patients have a pre-existing immune response to AAV vectors in the form of vector-neutralizing antibodies.¹⁴ Other research confirmed that 30% of screened patients had pre-existing antibodies against the AAV8

<https://doi.org/10.1016/j.omtm.2021.11.007>

Correspondence: Shunji Tomatsu, MD, PhD, Department of Biomedical Research, Nemours/Alfred I. duPont Hospital for Children, 1600 Rockland Road, Wilmington, DE, USA.

E-mail: stomatsu@nemours.org



Table 1. LSDs and therapeutic management

Disease	Eponym	Stored material	Defective enzyme ⁵	Standard of care ⁵	Gene therapy clinical trials	
Action myoclonus	renal failure syndrome	unidentified ⁹⁵	Lysosomal integral membrane protein (LIMP-2)	none		
Aspartylglucosaminuria		glycoproteins ⁹⁶	aspartoglucosaminidase	HSCT		
Ceroid lipofuscinosis 1	Batten disease		palmitoyl-protein thioesterase 1 (PPT1)	HSCT	AAV GT (NCT00151216; NCT01161576; NCT01414985)	
Ceroid lipofuscinosis 2	late infantile neuronal ceroid lipofuscinosis (LINCL)		tripeptidyl peptidase	ERT	AAV GT (NCT00151216; NCT01161576; NCT01414985)	
Ceroid lipofuscinosis 3	juvenile neuronal ceroid lipofuscinosis		lysosomal transmembrane protein	none	AAV GT (NCT03770572)	
Ceroid lipofuscinosis 4	Parry disease	lipofuscin ⁹⁷	cysteine string protein alpha (CSP α)	none		
Ceroid lipofuscinosis 5	Finnish variant of NCL		CLN-5	none		
Ceroid lipofuscinosis 6	late-infantile/early juvenile NCL		transmembrane ER protein CLN-6	none	AAV GT (NCT02725580; NCT04273243)	
Ceroid lipofuscinosis 7	late infantile variant		lysosomal membrane protein	none		
Ceroid lipofuscinosis 8	–		protein CLN-8 (Subunit c of mitochondrial ATP synthase)	none		
Ceroid lipofuscinosis 9	–		unknown	none		
Ceroid lipofuscinosis 10	–		cathepsin D	none		
Ceroid lipofuscinosis 11	–		granulin precursor	none		
Ceroid lipofuscinosis 12	juvenile parkinsonism–neuronal ceroid lipofusciosis			cation-transporting ATPase 13A2	none	
Ceroid lipofuscinosis 13	Kufs disease type B			cathepsin F	none	
Ceroid lipofuscinosis 14	progressive myoclonic epilepsy			potassium channel tetramerization domain containing ⁹⁸	none	
Cobalamin F-type disease	–		cobalamin ⁹⁹	LMBD-1	none	
Cystinosis	–		cystine ⁵⁵	cystinosis or CTNS	Cysteamine	LV GT (NCT03897361)
Danon disease	–		absence of lamp2 protein ¹⁰⁰	LAMP-2	none	AAV GT (NCT03882437)
Fabry disease	–	glycosphingolipids ¹⁰¹	α -galactosidase A	ERT	LV GT (NCT02800070, NCT03454893); AAV GT (NCT04519749; NCT04046224; NCT04040049)	
Farber lipogranulomatosis	–	ceramide ¹⁰²	acid ceramidase	HSCT		
Fucosidosis	–	Fucosylated glycoconjugates ¹⁰³	α -1-fucosidase	HSCT		
Galactosialidosis	–	galactosialidosis ¹⁰⁴	combined deficiency of β -galactosidase and neuraminidase	none		
Gaucher disease (types I, II, and III)	–	glucocerebroside ¹⁰⁵	β -glucocerebrosidase	ERT; PCT; SSI; HSCT	LV GT (NCT04145037, NCT00001234, NCT00004294); AAV GT (NCT04836377)	
GM1 Gangliosidosis	–	GM1 ganglioside ¹⁰⁶	β -galactosidase	HSCT	AAV GT (NCT04273269; NCT03952637)	
GM2 Gangliosidosis type I	Sandhoff disease	GM2 ganglioside ¹⁰⁷	β -hexosaminidase B	PCT	AAV GT (NCT04798235, NCT04669535)	

(Continued on next page)

Table 1. Continued

Disease	Eponym	Stored material	Defective enzyme ⁵	Standard of care ⁵	Gene therapy clinical trials
GM2 Gangliosidosis	GM2 activator deficiency		GM2 ganglioside activator	none	
GM2 Gangliosidosis type I	Tay-Sachs disease	GM2 ganglioside ¹⁰⁸	β -hexosaminidase A	PCT; SSI	AAV GT (NCT04669535)
Globoid cell leukodystrophy	Krabbe disease	galactocerebroside ¹⁰⁹	galactocerebrosidase	HSCT	AAV GT (NCT04693598)
Metachromatic leukodystrophy	–	sulfatides ¹¹⁰	arylsulfatase A	HSCT	LV GT (NCT02559830; NCT03725670; NCT04283227; NCT01560182; NCT03392987)
Mucopolipidosis I	sialidosis type I, II		α -acetyl neuraminidase	none	
Mucopolipidosis IV	–	mucolipids ¹¹¹	cation channel mucolipin 1	none	
Mucopolipidosis type II and III	I-cell disease		GlcNAc-1-phosphotransferase	none	
MPS type I	Hurler; Hurler-Scheie or Scheie syndrome	HS, dermatan sulfate	α -L-iduronidase	ERT; HSCT	LV GT (NCT03488394); AAV GT (NCT03580083); ZFN (NCT02702115); SB (NCT04284254)
MPS type II	Hunter syndrome	HS, dermatan sulfate	2-iduronate sulfatase	ERT; HSCT	LV GT (NCT00004454); AAV GT (NCT04571970; NCT03566043; NCT04597385); ZFN (NCT03041324)
MPS type IIIA	Sanfilippo syndrome type A	HS	N-sulfoglucosamine sulphydrolase	none;	LV GT (NCT04201405); AAV GT (NCT04088734; NCT04360265; NCT03612869; NCT02716246)
MPS type IIIB	Sanfilippo syndrome type B	HS	α -N-acetylglucosaminidase	ERT	AAV GT (NCT03315182; NCT04655911)
MPS type IIIC	Sanfilippo syndrome type C	HS	acetyl-CoA: α -glucosamine acetyltransferase	none	
MPS type IIID	Sanfilippo syndrome type D	HS	N-acetylglucosamine 6-sulfatase	none	
MPS type IVA	Morquio syndrome type A	keratan sulfate, chondroitin sulfate	N-acetylgalactosaminide 6-sulfatase	HSCT; ERT	
MPS type IVB	Morquio syndrome type B	keratan sulfate	β -galactosidase-1	none	
MPS type VI	Maroteaux-Lamy syndrome	dermatan sulfate	N-acetylgalactosamine 4-sulfatase	ERT; HSCT	AAV GT (NCT03173521)
MPS type VII	Sly syndrome	HS, dermatan sulfate, chondroitin sulfate	β -glucuronidase	ERT; HSCT	
MPS type IX	Natowicz syndrome	hyaluronan ¹¹²	hyaluronidase-1	none	
Multiple sulfatase deficiency	Austin disease	GAG and sulfatides ¹¹³	multiple sulfatases	none	
Niemann-Pick A and B	–	lipid ¹¹⁴	acid sphingomyelinase	none	
Niemann-Pick C	–		NPC1 or NPC2	SSI	
Glycogen storage disease type II	Pompe disease	glycogen ¹¹⁵	acid maltase or acid alpha-glucosidase	ERT	LV GT (NCT03454893); AAV GT (NCT02240407; NCT03533673; NCT04174105; NCT04093349)
Schindler disease	Kanzaki disease	glycoproteins ¹¹⁶	α -N-acetylgalactosaminidase	none	
Sialic acid storage disease	–	sialic acid ¹¹⁷	sialin	none	
Wolman disease	–	cholesterol esters ¹¹⁸	lysosomal acid lipase	HSCT	
β -mannosidosis	–	β -mannosidose	β -mannosidase	none	

AAV GT, AAV gene therapy; HSCT, hematopoietic stem cell therapy; SSI, specific substrate inhibition; PCT, pharmacological chaperone therapy; LV GT, lentiviral-mediated gene therapy under clinical trial with modified hematopoietic stem cells; SB, sleeping beauty transposon; ZFN, genome editing by the zinc finger nuclease.

Clinical trials numbers were taken from clinicaltrials.gov (access date 8/3/2021).

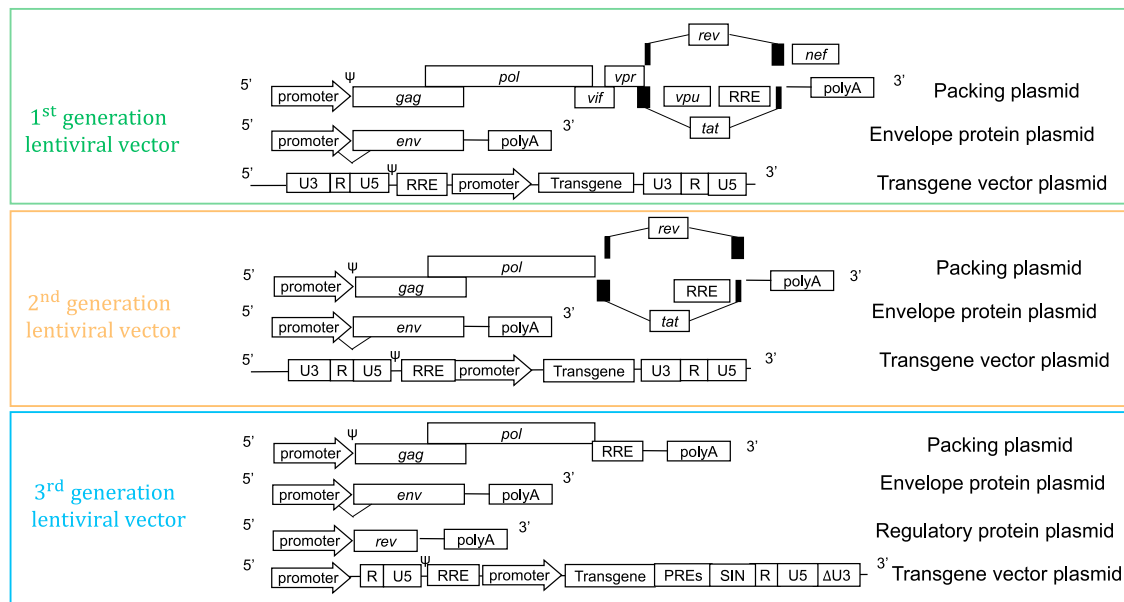

Figure 1. Three generations of lentiviral vectors

The first generation contained the *nef*, *vif*, *vpu*, and *vpr* genes—the HIV-specific accessory genes and the *gag* and *pol* genes necessary for the life cycle of the virus. Envelope protein (*env* gene) is used as another element to extend tropism of LV, called pseudotyping of the virus.⁹¹ Pseudotyping of the virus could enhance the expression of the transgene as the surface protein of the virus capsid can target cells.⁹² The commonly used envelope protein is vesicular stomatitis virus G protein (VSV-G), owing to the recognition of ubiquitously expressed receptors present on many cells, allowing the infection of various cell types. The second generation of LVs does not contain the accessory virulence factors. They still contain the transcription activator (*tat* gene) and the regulatory protein (*rev* gene). The third generation of LVs was created so that the viral genome was divided into four expression cassettes: envelope protein, two packaging cassettes, and gene of interest expression cassettes to increase the expression and safety. The genes necessary for the construction of the virus are found on the packaging cassette, where one plasmid vector contains the *gag* and *pol* genes, and the other plasmid contains the *rev* gene. Additionally, the third generation of the virus lacks the *tat* gene, and its expression function is replaced by an upstream LTRs construct that is continuously active.¹⁹ Moreover, to improve safety, a deletion in the 3' LTR was made to create self-inactivating (SIN) lentiviral vectors.⁹¹ poly(A), polyadenylation; RRE, Rev-responsive element; ψ , required for packaging of the genomic tRNA; SIN, self-inactivating element; LTRs contains three elements: U3, R, and U5, in third generation enhancer U3 in the 3' LTR is deleted

vector, and in most cases, cross-reactivity to AAV2 and AAV5 was detected.¹⁵ Notably, antibodies against AAV can be detected at birth, suggesting maternal antibody transmission to the newborns.¹⁶

LV vectors have a higher capacity for the potential gene (≤ 15 kbp) and broad tissue tropism that can be accomplished using various viral envelopes.¹⁷ One of the significant discoveries in LV is that these viruses infect both dividing and nondividing cells and integrate into the host chromosome. Therefore, LV vectors display stable and long-term expression of the transcript. However, this could also be a disadvantage since they can activate oncogenes close to LV integration¹³ or cause the silencing of genes necessary for cells. LVs include several different viruses by genus: the simian immunodeficiency virus, human immunodeficiency viruses (HIV-1 and HIV-2), and diverse non-primate LVs. The first developed and most commonly used lentiviral vector was based on HIV-1, which effectively transduces nondividing cells.¹⁸ Three generations of HIV-1 based LVs have been produced over the years owing to the biosafety concerns of using a highly infectious virus (Figure 1).¹⁹ Nevertheless, the HIV-1 backbone could be modified further. Vectors can be created by combining two viruses, fusing the backbone of one virus and expression element from the

other virus,¹⁹ or deleting part of sequences from HIV-1 (SMPUR vector) (Figure 2).²⁰

Furthermore, a modulation of the transgene expression cassette could be critical for clinical settings. Increased or decreased levels of the transgene could be adjusted to clinical needs to reduce adverse effects such as overexpression of the therapeutic gene.²¹ Yet, this is a multi-variable problem between vector copy, integration site, and promoter choice.²² The lentiviral vector expression cassette with the target transgene can be modulated depending on the need. The essential components of the lentiviral vector include enhancer/upstream promoter, promoter, the gene of interest, inverted terminal repeats/LTR, and polyA signal sequence.²³ Other frequently used *cis*-acting elements are introns and post-transcriptional regulatory elements (PREs) to ensure a high-level transgene expression.

PREs also protect the transgene from silencing. One of the most widely used PREs is WPRE from Woodchuck hepatitis virus, where the transgene expression increased 8.6-fold relative to a cassette without WPRE *in vitro*.¹⁹ Another part of the expression cassette that can increase the transgene expression is the polyadenylation

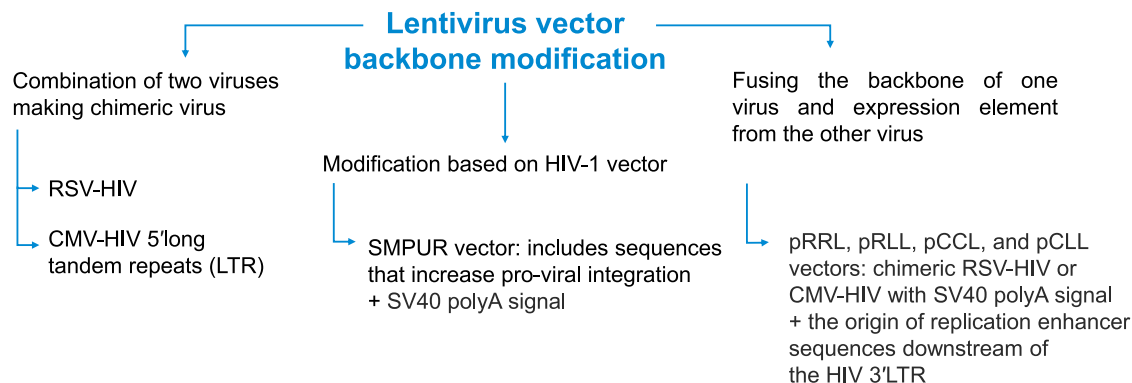

Figure 2. Lentiviral vector backbone modifications

The SMPUR vector is absent in the self-inactivating sequences in the expression cassette and includes sequences that increase pro-viral integration. It includes sequences from SV40, which can increase polyadenylation efficiency from the 3' LTR2620. There are differences in fusing the elements in pRRL, pRLL, pCCL, and pCLL. In pRRL, both enhancer and promoter are from RSV virus U3 region joined to the R region of the long terminal repeats in HIV-1 virus. In pRLL, an enhancer from the RSV enhancer is joined to the promoter region of HIV-1. In pCCL, both enhancer and promoter from the CMV are joined to the R region of HIV-1. In pCLL, only the CMV enhancer is joined to the promoter region of the HIV-1.¹⁹ RSV, Rous sarcoma virus; SV40, simian virus 40.

(poly[A]) site of the transcript. It is crucial for mRNA transportation from the nucleus and then increasing its stability and efficiency of translation. The polyadenylation signal sequence has been placed upstream of the enhancer in the expression cassette to improve efficiency. When polyadenylation signal and WPRE elements were compared in SV40, both improved transgene expression to a similar level.²³

LVs in gene therapy can be divided into two categories, depending on the administration route, either *in vivo* and *ex vivo*. In the *in vivo* route, the LV is introduced directly into the host by intravenous or intrabrain administration. In contrast, the *ex vivo* approach takes advantage of the virus-mediated transduction of the isolated HSCs of the host cells and then a reintroduction of these modified cells into the same patient.²⁴ Preclinical studies using mouse models need donor and recipient differentiation, because it is impossible to isolate enough cells from the same mice to make the transduction. Figure 3 describes the process of *in vivo* and *ex vivo* gene therapy in the mouse model. Local brain administration of lentiviral vectors has shown broad and stable transgene expression through different cells, transducing most brain cells in animal experiments, such as neurons and astrocytes. LVs have been used in many neurological diseases, and LSDs are potential target applications.²⁵

Selecting the proper promoter is crucial to obtaining effective transgene production within the cells.²⁶ The promoter is a major cis-acting element found at the beginning of the gene to be transcribed. Attaching RNA polymerase to the binding site of the promoter activates the transcription of the desired gene. Promoters dictate the overall strength of gene expression and direct tissue or cell target specificity.²³ During the last decade, different promoters, including both tissue-specific and housekeeping, have been used to treat LSDs (Figure 4).

This review summarizes the promoters of lentiviral vectors used for LSDs, and it will help to guide future experiments with lentiviral vector gene therapy.

PROMOTERS

Housekeeping promoters

Phosphoglycerate kinase promoter

Phosphoglycerate kinase (PGK) promoter has been widely tested for transgene expression for a long time showing vigorous activity in different kinds of tissues as murine embryonal stem²⁷ or myeloid cells, including mature neutrophils.²⁸

MPS IIIA is one of the most common mucopolysaccharidoses (MPS), caused by a deficiency of heparan N-sulfatase, resulting in the accumulation of glycosaminoglycan (GAG), heparan sulfate (HS). Among the first use of lentiviral therapy in MPS, LV bearing a transgene under the control of the PGK promoter was injected intravenously into 5-week old-MPS IIIA mice. After 6 months of treatment, the GAG content was decreased compared with untreated animals. Moreover, the weight of mice became normalized. However, enzyme activity and vector copy number within organs have not been checked.²⁹

Direct intracerebral injection into neonatal Krabbe mice of an LV expressing the gene coding for the missing galactocerebrosidase under the PGK promoter showed robust transduction of nerve cells with a minimal inflammatory response. Enzymatic activity in the central nervous system increased 8 days after injection. Direct administration at an early stage of the disease led to partial degradation of the storage material and increased the mouse lifespan. However, 6 months after initiation of the therapy, it was noted that the LV genome was only detected in the injection region of the brain.³⁰ Similarly, the maximum intensity of the vector copy number per cell was visible at the LV injection,³¹ indicating that lentiviral vectors cannot spread

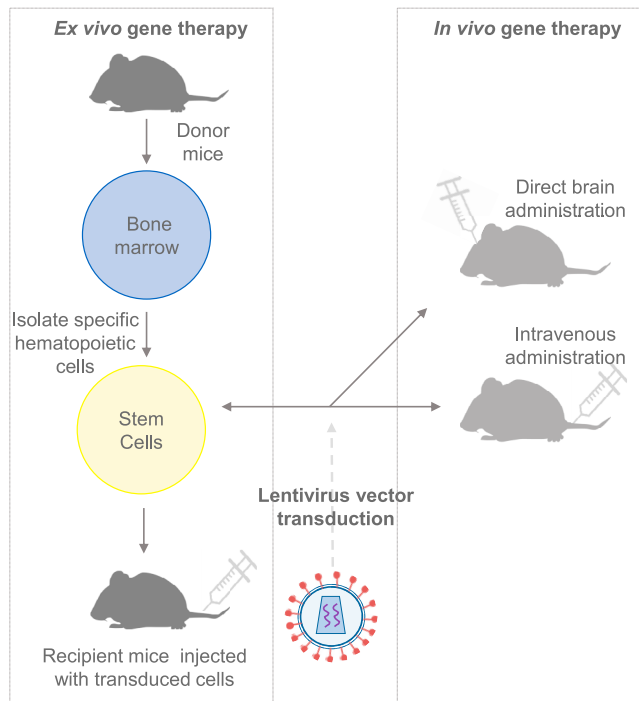

Figure 3. Ex vivo and in vivo gene therapy in animal models

In *ex vivo* gene therapy, stem cells are isolated from the donor mice, transduced with LV vector, and injected into recipient mice. *In vivo* gene therapy approach is a direct administration of the virus to the brain (intraparenchymal, intracerebroventricular, or intracisternal) or intravenously.⁹³

throughout the brain after direct injection. In contrast, the AAV has shown the ability to spread by axonal transport within the brain.³²

One of the first research with the PGK promoter in *ex vivo* LV treatment was conducted in the xenograft murine model of MPS VII. Peripheral blood CD34⁺ cells from MPSVII mice were transduced with a LV vector expressing β -glucuronidase enzyme under PGK promoter. Were injected 5- to 10-week-old mice with transduced cells after radiation conditioning. Enzyme activity was measured in the human cells ($10.8 \pm 1.6\%$) in the bone marrow from animals. Vector copy number in bone marrow 12 weeks after transplantation was 1–2 per positive cell. After transplantation, lysosomal storage decreased in the liver.³³ The PGK promoter also has been used in *ex vivo* lentiviral-mediated therapy. MPS I mice were injected intravenously with transduced cells with the lentiviral vector encoding the IDUA gene (or cDNA). After 6 months of therapy, GAG levels were normalized in urine and tissues (liver, spleen, and kidneys). The enzyme activities in organs (liver, spleen, kidney, heart, and brain) were higher than that in HSCT. Additionally, animal behavior in treated mice was improved with *ex vivo* gene therapy, which was not noted in the mice that underwent HSCT. Patients with MPS I suffer from progressive severe skeletal dysplasia. The *ex vivo* lentiviral-mediated gene therapy has shown improvement of skeletal dysplasia in MPS I mice.³⁴ The PGK promoter was also used in globoid cell leukodystrophy (also called Krabbe dis-

ease) *ex vivo* gene therapy. Transgene expression was optimized by adding miRNA to the expression cassette.³⁵ The overexpression of the galactocerebrosidase enzyme was shown to be toxic to the HSCs.³⁶ To regulate the expression of the enzyme, specific miRNA has been identified (miR-126 and miR-130a). Incorporating the miRNA and codon-optimized human enzyme cDNA into the expression cassette resulted in selective and increased enzyme activity within the only transduced hematopoietic stem and progenitor cells compared with untreated mice.³⁶ Transplantation followed by virus transduction of cells taken from mice showed that the missing enzyme activity increased shortly after implanting the cells into the donor mice. More prolonged survival and improved phenotype were noted in the cell-transplanted mice compared with the untreated mice. A correlation between the vector copy number in the bone marrow isolated from the mice and increased enzyme activity was noted. Enzyme activity in the brain, the most affected organ in Krabbe disease, was only slightly increased without statistical significance ($4 \pm 0.5 \text{ nmol/mg} \times \text{h}$) compared with untreated mice (undetected), suggesting that it could correlate with the PGK promoter not being expressed explicitly in brain.³⁵ In this case, the added miRNA did not affect decreased expression, because the control vector (also with PGK) did not have higher expression in the brain than the tested vector.³⁵

One of the most common LSDs is Gaucher disease. Although patients have many treatments available,⁵ patients can be unresponsive to ERT or have problems finding a suitable HSCT donor. Lentiviral vector therapy with transgene expression under the control of ubiquitous PGK or macrophage-specific CD68 promoters has been tested in a mouse model of Gaucher disease. After transduction of cells and transplantation to mice, enzyme activity increased compared with untreated mice, leading to the clearance of glucosylceramide and reversal of phenotype in both tested promoters groups. The PGK promoter has shown a higher (2 ± 1 copies/cell) vector copy number in bone marrow and higher enzyme expression levels compared with untreated animals.³⁷

Human clinical trials (NCT01560182, NCT04283227) with *ex vivo* lentiviral-mediated therapy have been conducted in metachromatic leukodystrophy, where neurological dysfunctions lead to a rapid progression of the disease, eventually causing death within a few years after the first symptoms occur. Three presymptomatic patients have been infused with LV-transduced cells expressing the ARSA enzyme under the PGK promoter. These patients have shown stable expression of the enzyme throughout hematopoietic lineages and in cerebrospinal fluid. Moreover, disease progression has not been seen, even after the predicted age of symptom onset.^{38,39} Primary outcomes from the second clinical trial (NCT04283227) indicate an increase in enzyme activity in cerebrospinal fluid as well as in neuronal metabolite ratio of *N*-acetyl-aspartate to creatine (<https://www.clinicaltrials.gov/ct2/show/NCT04283227> accessed July 13, 2021).

Cytomegalovirus promoter

Cytomegalovirus (CMV) promoter is another strong promoter with housekeeping expression. It was tested in different tissues such as

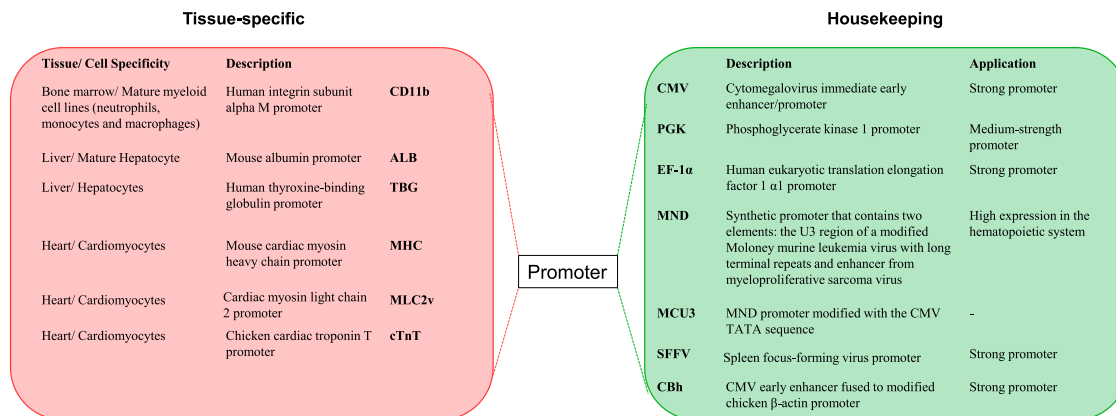

Figure 4. Lentiviral vector promoters used in LSDs (based on⁹⁴)

Promoters can be divided into two groups depending on their expression site: tissue-specific (CD11b;^{75,119} ALB;¹²⁰ TBG;⁷² MHC;¹²¹ MLC2v;^{122,123} cTnT;^{124,125}) or ubiquitous/housekeeping (CMV;^{126,127} PGK;^{27,127,128} EF-1 α ;^{43,127} MND;⁵⁷ MCU3;^{58,59} SFFV;^{129,130} CBh;¹³¹). If the recombinant gene product is to be secreted in all cell types, then housekeeping/ubiquitous promoters are preferable. Conversely, tissue-specific promoters can be used to express the recombinant gene product in one specific tissue, such as neurons or astrocytes, to treat central nervous system damage.²³ Moreover, syntenic promoters, which are chimeric promoters composed of natural promoters, can be produced to optimize the transgene expression and enhance the precision of the infection.⁶³

myeloid cells, including mature neutrophils showing vigorous activity in lentiviral gene transduction.²⁸

LV bearing the *IDUA* gene under the control of the CMV promoter was administered into MPS I mice by direct tail injection. The highest concentrations of IDUA were found in the liver and spleen. Polymerase chain reaction analysis demonstrated that the integration of the viral genome took place only in the liver and spleen, which means that the cross-correction mechanism carried out the reduction of GAG levels in the remaining tissues. During long-term analysis (6 months), the presence of antienzyme antibodies and decreased enzyme activity, as well as decreased vector integration, were noted. Probably owing to a substantial immune response, the transgene was no longer present after long-term treatment.⁴⁰

In contrast, in Pompe disease, owing to enzyme acid α -glucosidase deficiency, glycogen accumulates mainly in the heart and skeletal muscles, resulting in devastating symptoms. The direct intravenous administration of CMV-LV vector to newborn knockout Pompe disease mice led to transgene expression in the liver and heart for up to 24 weeks. A decrease in the glycogen level was seen in skeletal and cardiac muscles after a single injection without an immune reaction in most 41 mice⁴⁴ (out of 43 mice, 3 had antibodies against enzyme).⁴¹

The choice of the promoter or determination of a particular sequence included in the expression cassette was the subject of extensive analysis performed by Ou et al. (2016).⁴² Four promoters have been compared in MPS I mice: PGK, EF-1 α , CMV, and the synthetic CE promoter (composed of the enhancer of the murine CMV immediate-early gene and human EF-1 α promoter) with different WPRE variants. All tested promoters decreased GAG levels in the liver, whereas GAG levels were decrease with only CE and particular WPRE modification in the brain and spleen. Similarly, enzyme activ-

ity was expressed in liver in all of the tested promoters, while the enzyme activity in spleen and brain significantly increased only by CE promoter. Additionally, this promoter provided the lowest transgene frequency in the gonads, which is important in using LVs to integrate into the host genome, reducing the potential germline transmission.⁴² When comparing four variants of the WPRE in the CE promoter, one of them has the highest expression, suggesting that promoters are less important in the expression than additional transcription regulators.⁴²

Elongation factor-1 α promoter

Eukaryotic translation elongation factor 1 α promoter is a strong native promoter, expressed in almost all kinds of mammalian cells.⁴³ One of the most used housekeeping promoters in LSDs.

Although LV is an effective tool in disease correction, its integration ability could lead to serious adverse effects by oncogene activation.⁴⁴ An analysis of the distribution of integration sites of the LV has been performed in a metachromatic leukodystrophy mouse model. Four-week-old mice were intracranially injected with LV expressing the ARSA enzyme under the EF1- α promoter. The LV integration sites profile was measured in the murine brain ependymal cells. There was preferable integration within tandem repeats (e.g., satellite DNA). Moreover, host non-B DNA motifs were identified as a possible factor contributing to the LV integration sites. Most important, none of the integration sites were detected in or within 50 kb to known oncogenes.⁴⁵ A comparison of two different strategies of vector delivery (either by intravenous injection or by ventricular infusion) was assessed in 6-week-old MPS VII mice. The same vector has been used in both cases, with the EF-1 α promoter.⁴⁶ After 7 months from an intravenous injection, vector delivery proved effective in restoring enzyme levels in the liver. Moreover, most somatic and brain pathology was corrected with improved behavior. However,

intraventricular vector delivery reduced lysosomal storage in the central nervous system, biochemically and histologically normalizing brain pathology and mouse behavior. Additionally, a reduction of lysosomal storage was evident in the eyes of mice. Ventricular vector delivery was more effective in brain-related disease outcomes.⁴⁶

In another study, when a lentiviral vector with the same promoter was administrated into two different MPS VII newborn mice, the enzyme level was normalized after 12 and 18 months of the therapy. Elevated enzyme levels resulted in lysosomal storage reduction in the liver, spleen, kidney, and heart. Moreover, bone mineral volume decreased in both mouse models with improving behavioral analysis. The significantly prolonged life span of the mice was also observed after administration of LV in neonatal mice.⁴⁷ In contrast, MPS VII mice fully manifesting skeletal symptoms have been administered with a lentiviral vector expressing β -glucuronidase, driven by the EF-1 α promoter. After 2 months from the administration, skeletal pathology has been reversed.⁴⁸ Direct brain delivery has been used for lentiviral gene therapy in MPS IIIA mice. Vectors bearing the transgenes were delivered to the cerebral lateral ventricles. Two lentiviral vectors were tested in that study, and in both cases, EF-1 α gene promoter was used.³¹ The difference between them was that one expressed codon-optimized murine heparan *N*-sulfatase, while the other expressed both heparan *N*-sulfatase and sulfatase modifying factor-1. After 6 months from the intraventricular injection, the behavior was improved, and bladder distension was not seen in any treated mice. When the two vectors were compared, the simple one was more effective in increasing enzyme expression in the brain. This also translated into a reduction in ganglioside and elevation of lysosomal β -hexosaminidase levels.³¹ The most concerning issues in delivering the missing enzyme are those for the brain and bone. Most LSDs reveal dysfunctions of these organs, leading to a decline in the activity of daily living. Disability-related bone damage affects children with MPS I, II, IV, and VII, mucopolidosis types II and III, and Gaucher disease. Clinical symptoms may vary between LSDs and even between patients. Some patients are asymptomatic and without radiographic evidence of bone pathology. In contrast, others have obvious bone crises, short statures with typical dysostosis multiplex symptoms, bone deformations, or osteopetrosis with neurotic breaks.⁴⁹

Farber disease is one of the rare lysosomal diseases with lipid accumulation owing to ceramidase deficiency. *Ex vivo* gene therapy with EF1-1 α promoter was tested in nonhuman primates. To track the expression of the enzyme CD25 promoter, specific for T cells, was included in the expression cassette.

A preclinical study on nonhuman primates was conducted for Farber disease with a lentiviral vector expressing the gene coding for ceramidase from the EF-1 α promoter, with CD25 promoter included in the cassette to track expression,⁵⁰ specific for T cells.⁵¹ Peripheral blood was collected from animals, transduced with the virus, and reintroduced to the same animals, tracking therapy efficiency for one year. The transduced vector was found in bone marrow and peripheral

blood (PB) cells with decreased storage material in PB, liver, and spleen.⁵⁰

In Fabry disease, EF-1 α promoter has been used as well. Bone marrow mononuclear cells were transduced with a lentiviral vector encoding the human alpha-galactosidase A gene (or cDNA) and were injected into the Fabry mouse model. Increased enzyme activity and reduction of the accumulated substrate were observed 20 weeks after cell transplantation.⁵² A more recent study also used the same promoter in the Fabry disease mouse model, leading to the increased level of the enzyme and a reduced substrate 6 months after transplantation. In this study, the authors also tested LV transduction of CD34⁺ hematopoietic stem cells isolated from Fabry disease patients with a successful increase of enzyme activity. After mouse engraftment with LV-transduced CD34⁺ cells, the enzyme level was increased, and lipid storage material accumulation decreased.⁵³ Currently, this approach is under clinical investigation with EF1- α promoter (NCT02800070) for Fabry disease. Five male patients with the type 1 phenotype have been evaluated for safety and efficiency of the treatment after up to 1,000 days after the infusion of the transduced cells. There were no serious adverse effects of the study, where only two patients could be potentially related to the investigational product (nausea, grade 1; cough, grade 2). After 1 week of treatment, all patients produced the normal level of the enzyme with a decrease over time. Reduction of accumulated substrates has been noticed in plasma and urine of the patients.

Moreover, the anti- α -galactosidase A antibody level increased in one of the patients and then rapidly decreased. However, only one patient was treated with gene therapy exclusively and sustained low levels of accumulated substrates in plasma and urine owing to gene therapy only.⁵⁴ The other four patients resumed ERT 1 month after transplantation. Another *ex vivo* lentiviral-mediated gene therapy is also under investigation in a clinical trial in patients with Fabry disease (NCT03454893), but the type of promoter is not being disclosed in this case.

In cystinosis, cystine is accumulated in all tissues, mostly in kidneys, and cysteamine is the only available therapy.⁵⁵ Nevertheless, gene therapy with transduced HSCT (*ex vivo*) has been tested in a mouse model of cystinosis with EF-1 α promoter. Intravenous treatment with transduced cells decreased accumulated material in every tissue, improving kidney function as well. Moreover, the correlation between transgene expression in PB and tissues was shown, which could be helpful for patient treatment, suggesting a cross-correction mechanism.⁵⁶

MND vector

The MND is a synthetic promoter that contains two elements: the U3 region of a modified Moloney murine leukemia retrovirus with long terminal repeats and an enhancer from the myeloproliferative sarcoma virus. It is a constitutive promoter with high expression in the hematopoietic system.⁵⁷ Either neonatal, 1–2 days old, or 8-week-old MPS I mice have been intravenously injected with a lentiviral vector expressing the IDUA enzyme under the MND synthetic promoter. At 5 months old, mice have been euthanized. It has been

noted that, if lentiviral-mediated gene therapy is given early enough, IDUA activity also appears in the brain of MPS I mice, with increased neuron transduction.

Additionally, a reduction in GAG levels, prevention of the appearance of skeletal abnormalities, and increased life expectancy have been noted in neonatal mice.²⁰ Furthermore, the MND promoter has been modified with the CMV TATA sequence to activate and sustain expression in hematopoietic human stem cells. Part of the MND was used for the internal promoter that is replaced with the TATA sequence of the human CMV promoter, which is called the MCU3 promoter.^{58,59} LVs with either MND or MCU3 promoters are not cell-specific promoters, but can be widely introduced into nondividing and dividing cells. One of the approaches presented combination therapy of two different vectors expressing the NAGLU enzyme in MPSIIIB neonatal mice. AAV vector was injected intracranially while LV with MND promoter was injected intravenously. In the case of this combination therapy, we could see an improvement in behavioral analysis (motor function and hearing) as well as an increased lifespan of the animals. Brain enzyme activity was not detected in lentiviral gene therapy only, increased only in combination therapy of both viruses. Systematic enzyme activity in LV treatment was increased, while with combination therapy, this activity decreased (liver, 0.55-fold normal activity LV alone; 0.1-fold normal activity in combination treatment with AAV).⁶⁰ This could be correlated with increased antibodies against the enzyme, which was not measured in these experiments.⁶¹

Ex vivo lentiviral-mediated gene therapy with the MCU3 promoter was administered into MPS II mice, where brain and bone are mostly affected. Consequently, neurological and peripheral GAG accumulation was corrected.⁶² They have not mentioned bone alternation where the skeletal system is affected in MPS II disease.⁶³ In contrast, another study investigated bone pathology in MPS II with the same LV vector.⁶⁴ This therapy reduced bone GAG accumulation, improving bone volume, density, strength, and trabecular number. Nevertheless, in that study, irradiation was used for myeloablation, normally affecting bone complications. The authors suggested that irradiation did not affect bone formation, resorption parameters, and mineral density in the diaphysis edge, evaluated by micro-computed tomography scans.⁶⁴ Different preconditioning doses with irradiation were tested in MPS II mice as the intense irradiation could effectively lead to bone complications, a high mortality rate, and morbidity.⁶⁴ Three different doses were tested: low dose, low-dose irradiation plus an anti-c-kit monoclonal antibody, and high dose. The iduronate-2-sulfatase (IDS) activity was high in all peripheral tissues with a robust decrease in GAG accumulation no matter what dose was used. Notably, animal behavior was improved only at the highest dose, and the storage material was reduced in the brain, indicating how important it is to precondition the efficient engraftment of the modified cells.⁶⁵ It is noted that there could be a correlation between the choice of the promoter and irradiation as the myeloablation method. Irradiation could activate specific transcriptional control elements within promoters affecting increased transgene expression through radiation-induced promoters.^{66–68} This approach was tested in cancer

cell gene therapy for early growth response 1 (Egr1) gene promoter, where radiation resulted in the response of transcriptional enhancers.⁶⁹ However, in the discussed research, this theory has not been tested.

Spleen focus-forming virus promoter

The spleen focus-forming virus (SFFV) promoter was used in *ex vivo* lentiviral-mediated gene therapy to treat MPS IIIA mice.⁹ In this study, the donors of stem cells were derived from either wild-type (WT) mice or MPS IIIA mice, further transduced with the lentiviral vector bearing the gene for the missing enzyme (LV-WT-HSCT or LV-IIIA-HSCT), and injected into MPS IIIA mice. These LV-HSCT-treated groups were compared with the traditional transplantation group (WT-HSCT). Both of the LV-transduced groups had effective engraftment within the donor, reaching more than 88%. Only the LV-WT-HSCT experimental group corrected the behavior of the MPS IIIA mice. The brain enzyme activity in LV-WT-HSCT mice was detected up to 10% of WT mouse level, and ganglioside and HS levels were reduced. MPS IIIA-LV transduced or WT-HSCT mice have not shown a significant improvement in animal behavior.

Neuroinflammation and GM2 gangliosides were reduced, but HS levels remained elevated. This finding suggests that HS storage has a more significant impact on neuropathology than neuroinflammation as the mouse behavior was not changed.⁹

In the latest study, the same promoter has been used to treat mice with Pompe disease.⁷⁰ ERT is available for Pompe disease. However, one-half of the patients with Pompe disease die before the age of 3 years despite ERT. Previously, the same group using this promoter with *ex vivo* lentiviral-mediated therapy has shown an overexpression of the enzyme and decreased the accumulated glycogen levels in the heart, diaphragm, spleen, and liver. Improvements in cardiac and respiratory function, skeletal muscle strength, and locomotor behavior were observed as well. In this study, the donor cells were from male mice while female recipient mice are different experimental models for *ex vivo* gene therapy.⁷¹ The same experimental design with male mice as a donor and female mice as a recipient in *ex vivo* gene therapy was recently published. Lentiviral vector cassette expression also included SFFV promoter; the difference was the optimization of the open frame of the enzyme for improved expression included Kozak sequence and an additional TGA stop codon. After 12 months of treatment, a near normalization of glycogen level was observed in heart muscles with complete locomotor behavior improvement. Even though glycogen accumulates in the brain of patients with Pompe disease, there are no prominent neurological symptoms. However, this accumulation could increase the severity of other symptoms like respiratory insufficiency and skeletal dysfunctions. The reduction of accumulated glycogen in the brain was visible with increased enzyme levels in microglia and the enzyme expression in all treated astrocytes.

Moreover, this particular research was the only one that checked the integration site of the lentiviral vector within the genome from all of

the reviewed articles. Because LVs could be randomly integrated throughout the genome, activating oncogenes, this research is significant. They did not observe any preference for integration near proto-oncogenes.⁷⁰

Tissue-specific promoters

A tissue-specific promoter can be used to transduce specific cells or tissues directly. One study compared different promoters, such as the thyroxine-binding globulin (TBG) and other promoters. The activities of six promoters (CMV, EF1 α , PGK, apolipoprotein E [apoE], TBG, and cytochrome P450 2 \times 10¹ [CYP2E1]) were compared by introducing a transgene via a LV-mediated delivery system in the liver. The TBG promoter revealed high activity; its expression was less strong than the ubiquitous CMV and EF1 α promoters, while it was more robust than PGK, ApoE, and CYP2E1 promoters.⁷² Thus, this study showed promise for tissue-specific promoters, at least for liver transduction.

Liver-specific promoters

One way to efficiently express a transgene in gene therapy is to use the liver as a distributor of the missing enzyme. Owing to the cross-correction effect of lysosomal enzymes, this type of gene therapy targeting may be effective in the case of LSDs. When conducting a gene therapy study, the liver is the organ with the highest expression of the enzyme.⁵

A reduction of antibodies against the IDUA enzyme in the brain was noticed, and levels of ganglioside and lysosomal β -hexosaminidase were reduced after 6 months of treatment with a construct bearing the liver-specific promoter.³¹ In other studies, the albumin gene promoter, a hepatocyte-specific promoter in the liver, was used. After one month of treatment of 8- to 10-week-old MPS I mice, the IDUA enzyme was active in the liver and spleen. In addition, only a 1% increase of enzyme activity could reduce GAG levels in visceral organs such as the kidneys, heart, and lungs. The results do not include brain GAG levels and enzyme activity, although the brain is the most affected in patients with MPS I.⁴⁰ Nevertheless, in one of the newest studies for Fabry disease, a tissue-specific promoter that targets the liver was used with the AAV vector, not the lentiviral one, resulting in the supraphysiological enzyme level in plasma up to 1,061-fold of WT level and correction of lysosomal storage pathology in visceral organs, such as the liver, kidney, heart, and spleen.⁷³

Cardiac-specific promoters

Depending on which organ is affected, different tissue-specific promoters have been tested. In Fabry disease, cardiac manifestation is one of the most severe symptoms, as lipid material is also stored in the heart. Direct intravenous injection of the lentiviral vector in neonatal Fabry disease mice has been made, comparing four promoters. Three of them were myocardial-specific promoters: myosin heavy chain, myosin light chain, and cardiac troponin T, and the fourth was the ubiquitous EF-1 α promoter. After 10 weeks, enzyme levels in serum increased, and 18 weeks later, some decrease in storage

material has been observed in heart without notable differences between promoters.⁷⁴

Myeloid-specific CD11b promoter

The CD11b promoter myeloid specificity seems to be the best in hematopoietic stem cell therapy. After the introduction into the patient, cells first differentiate into macrophages, and in the brain, into myeloid cells.⁷⁵ In recent years, *ex vivo* lentiviral-mediated gene therapy with CD11b has been used in many LSDs, including MPS II,⁷⁶ IIIA,^{77,78} IIIB,⁷⁹ all of which are characterized by damage to the central nervous system.

During the *ex vivo* study, MPS IIIA mice were treated with the vector bearing the *SGSH* gene under the control of the ubiquitous PGK promoter and the myeloid-specific CD11b promoter. Both constructs expressed the missing enzyme.⁷⁷ Previously, the same group noted a partial improvement in the neuropathology in MPS IIIA mice with autologous LV-HSC gene therapy, where the expression of the missing enzyme was under the control of the SFFV promoter.⁹ However, owing to the insufficient enzyme activity in the brain, they decided to combine it with the CD11b promoter, specifically targeting myeloid cells, which differentiate into microglial cells. As a result, the construct increased the expression of the missing enzyme in the brain. After 8 months of gene therapy, the CD11b promoter showed a higher level expression of the *SGSH* gene in the brain than the PGK promoter. The authors have also demonstrated the normalization of animal behavior, the GAG level in the brain, and neuroinflammation in the brain. The PGK promoter was only partially able to correct neuropathology without affecting animal behavior. However, both promoters caused the higher expression of the recombinant gene in bone marrow than untreated mice.⁷⁷

The same approach was applied to MPS IIIB mice with *ex vivo* lentiviral-mediated gene therapy with the CD11b promoter, ensuring the NAGLU enzyme expression, compared with NAGLU containing a C-terminal fusion to insulin growth factor 2 (IGFII).⁷⁹ Direct intracerebroventricular delivery of the missing enzyme fused to IGFII improved enzyme uptake of cells, as IGFII binds to the mannose-6-phosphate receptor in MPS IIIB mice.⁸⁰ After 8 months of treatment with LV-NAGLU, the enzyme was significantly increased with both vectors, either with IGFII or without. LV-NAGLU-IGFII-treated mice have shown limited enzyme secretion from engrafted macrophages in the brain, mimicking an *in vitro* experiment where LV-NAGLU-IGFII-treated cells did not secrete enzyme into the culture media.⁷⁹

As *ex vivo* lentiviral-mediated gene therapy with CD11b promoter has been successful in MPS IIIA,⁷⁷ IIIB,⁷⁹ and MPS II mice,⁷⁶ before clinical trial, preclinical safety and efficiency of the lentiviral vector have been evaluated for the treatment of MPS IIIA.⁸¹ Autologous HSCT gene therapy procedure starts with blood collection from the patient, and then CD34⁺ cells are isolated, transduced with LV, and reintroduced into the patient.⁸² Accordingly, CD34⁺ cells, isolated from blood, were transduced with a LV expressing *SGSH* under control

of the CD11b promoter. After optimizing the transduction conditions and the cryopreservation of CD34⁺ cells, biodistribution and genotoxicity were investigated in the mouse model. Effective transplantation and biodistribution without vector transmission to the germline cells have been reported, which is particularly important in the case of LVs.⁸¹

In all of the previous studies, the gene delivered by a lentiviral vector encoded the enzyme deficient in the disease. Alternatively, a lentiviral vector bearing the gene for an IL-1 receptor antagonist under control of the CD11b promoter was tested in MPS IIIA mice. The concept of this research was based on neuroinflammation as a possible cause of behavioral and cognitive disturbances. IL-1 receptor antagonist overexpression led to the receptor blockade that reduced gliosis and behavioral disturbances in mice.⁷⁸

A clinical trial with a lentiviral vector expressing the missing enzyme gene from the CD11b tissue-specific promoter with autologous CD34⁺ HSCT in MPS IIIA patients is ongoing (NCT04201405). This clinical trial started in January 2020, intending to enroll five patients (≥ 3 and ≤ 24 months of age) without any previous treatment, with a time frame of up to 3 years for the measurement of safety and efficacy.

CONCLUSIONS AND FUTURE DIRECTIONS

Various researches and achievements on *ex vivo* lentiviral-mediated gene therapy have been performed on synthetic promoters (MND, MCU3 promoters).^{62,64,65} Synthetic promoters comprise the leading promoter with an enhancer (cis-acting element) that is binding sites for transcription factors. They have more advantage over native promoters as the expression could be modulated, with where to express, when, and how much. Although the native promoter has the correct pattern of expression, it is not recommended to modify it.⁸³ For this reason, the native promoters are tested initially, where their expression could be regulated by different factors, such as codon optimization or adding the element like WPRE elements or miRNA.^{35,84}

A recent cancer incidence in two patients from clinical trials of lentiviral-mediated gene therapy (called Zynteglo) on sickle cell disease has been reported. Subsequently, the clinical trial has been suspended (NCT02140554). This trial has three treatment cohort groups, depending on the lentiviral vector manufacturing process to increase vector copy number and engraftment potential. One sickle cell disease patient treated for more than 5 years was diagnosed with acute myeloid leukemia in an experimental group treated with bone marrow isolated and LV-transduced cells. Moreover, the second patient in this clinical trial was diagnosed with myelodysplastic syndrome from another experimental group treated with cells collected from PB after mobilization with plerixafor and LV-transduction. Gene therapy with Zynteglo was already approved to treat beta-thalassemia in 2019 in the European Union. Zynteglo contains a lentiviral vector encoding the human β -globin gene under the internal erythroid-specific promoter.^{85,86} Both the US Food and Drug Administration and European Medicines Agency investigated the cause of

the cancer incidence. One of the potential contributory factors in sickle cell disease could be the increased potential for leukemia.⁸⁷

The solution to this problem may be nonintegrating LVs, which will increase the safety of this kind of gene therapy.⁸⁸ LVs that do not integrate into the host genome lack viral integrase enzymes by introducing a mutation in the packaging vector. Thus, the integration of LV is blocked. Consequently, they reside in the form of episomal transcriptionally active DNA and enables the LV vector to express the gene product.⁸⁹ Nonintegrating LVs have lower transgene expression levels compared with integrating LV owing to their episomal structure. These LVs form nucleosomes that lead to chromatin silencing associated with histone modification in this chromatin structure.⁹⁰ With a higher capacity for transgene and elimination of potential mutagenesis associated with integration, nonintegrated LVs have a potential advantage over AAV vectors. Additionally, a portion of the methodologies focuses on (1) increasing transgene expression, (2) constructing fused genes, and (3) adding tags to transgene protein in the expression cassette and to allow the transgene to deliver to the target tissue efficiently. In one of the recent studies, not only myeloid-specific CD11b promoter, but also ApoEII targeting brain receptors were used, leading to complete normalization of brain pathology and behavior in MPS II mice after *ex vivo* lentiviral-mediated gene therapy. Furthermore, enzyme activity was also higher in plasma when comparing with vectors without ApoEII modification, suggesting that the vector is taken up by both HS/ApoE-dependent receptors and mannose-6-phosphate receptors in the brain.⁷⁶ Delivering the missing enzyme through gene therapy is a promising approach for LSDs. Gene therapy needs optimization in dose, time of delivery, and promoter-driven expression. Throughout the years, several promoters have been used in *ex vivo* lentiviral-mediated gene therapy of LSDs. Vectors used in the *ex vivo* approach have a higher vector copy number than in *in vivo* gene therapy (Table 2). Clinical trials with *ex vivo* lentiviral-mediated gene therapy provide promising results with increased transgene expression. Choosing an appropriate promoter is crucial for obtaining the desirable effects of lentiviral gene therapy. The proper choice depends on the disease, target tissue, and organs. In some cases, a combination of promoters or the construction of fused and engineered promoters might give the best results. Based on the collected data we can conclude that tissue-specific promoters are not as good as the ubiquitous promoters. In clinical trials ubiquitous promoters (PGK, EF1- α) have promising results so far (NCT01560182, NCT04283227, NCT02800070). Further studies must construct effective systems to deliver and express desired genes into patients suffering from LSDs.

METHODS

Medical Subject Headings were applied for the selection of articles in this review process. In PubMed search, we have used the keywords of “lysosomal storage disease, LV, and gene therapy”; “lentivirus, gene therapy, and lysosomes”; “*ex vivo* gene therapy and lysosomal storage disease”; and “hematopoietic stem cell gene therapy and lysosomal storage disease” with time selection filter (2005–2020). We were focusing our research on preclinical

Table 2. Promoters used in lentiviral gene therapy in preclinical mouse models

Promoter	Disease/ age	Time	ADM	Dose	Vector copy number/cell								Ref.
					Liver	Spleen	Heart	Kidney	Brain	Lung	BM	WBC	
<i>In vivo</i>													
MND	MPS I 1–2 d	5 mo	IV	1.65×10^{11} TU/kg	0.045 ± 0.01	0.01 ± 0.001	0.002 ± 0.001	0.0007 ± 0.0001	0.008 ± 0.0001	–	–	–	Kobayashi et al. ²⁰
MND	MPS I 2 mo	5 mo	IV	6.88×10^9 TU/kg	0.01 ± 0.001	0.003 ± 0.0001	0.0007 ± 0.0001	0.0002 ± 0.0001	ND	–	–	–	
ALB	MPS I 2.0–2.5 mo	1 mo	IV	0.6×10^9 TU/kg	0.125 ± 0.01	0.24 ± 0.01	–	–	–	–	–	–	
ALB	MPS I 2.0–2.5 mo	6 mo	IV	0.6×10^9 TU/kg	0.2 ± 0.01	0.25 ± 0.003	–	–	–	–	–	–	di Domenico et al. ⁴⁰
CMV	MPS I 2.0–2.5 mo	1 mo	IV	0.6×10^9 TU/kg	0.075 ± 0.0001	0.2 ± 0.01	–	–	–	–	–	–	
CMV	MPS I 2.0–2.5 mo	6 mo	IV	0.6×10^9 TU/kg	ND	ND	–	–	–	–	–	–	
CMV	MPS I 2.0–2.5 mo	1 mo	IV	1.2×10^8 TU/mL	0.074 ± 0.018	0.83 ± 0.10	–	–	–	–	–	–	
CMV	MPS I 2.0–2.5 mo	6 mo	IV	1.2×10^8 TU/mL	0.0022 ± 0.003	0.0026 ± 0.001	–	–	–	–	–	–	
CMV	Pompe 1–2 d	6 mo	IV	NP	0.17 ± 0.035	–	0.095 ± 0.03	–	–	–	–	–	Kyosen et al. ⁴¹
PGK	MPS I 1–2 d	1 mo	IV	1×10^7 TU/g	0.026 ± 0.0064	0.02 ± 0.008	–	–	0.0025 ± 0.0016	–	–	–	Ou et al. ⁴²
CE	MPS I 1–2 d	1 mo	IV	1×10^7 TU/g	0.049 ± 0.025	0.015 ± 0.076	–	–	0.0006 ± 0.0002	–	–	–	
EF-1 α	MPS I 1–2 d	1 mo	IV	1×10^7 TU/g	0.098 ± 0.033	0.037 ± 0.001	–	–	0.0024 ± 0.0009	–	–	–	
EF-1 α	MPS VII 1 mo	6–7 mo	IV	0.3×10^9 TU	0.75 ± 0.19	0.11 ± 0.04	–	0.01 ± 0.004	–	0.01 ± 0.02	–	–	Bielicki et al. ⁴⁶
EF-1 α	MPS VII 1 mo	6–7 mo	ICV	1.2×10^7 TU	0.01 ± 0.01	0.004 ± 0.0004	–	ND	–	0.01 ± 0.001	–	–	
EF-1 α	MPS VII 1–2 d	12 mo	IV	2.1×10^6 TU	0.8 ± 0.1	0.11 ± 0.5	0.01 ± 0.001	0.07 ± 0.02	0.01 ± 0.001	0.075 ± 0.02	–	–	Derrick-Roberts et al. ⁴⁷
EF-1 α	MPS VII 4 mo	2 mo	IV	2×10^7 TU/mL	0.2 ± 0.1	0.2 ± 0.1	0.01 ± 0.001	0.0005 ± 0.0001	0.0005 ± 0.0001	0.0025 ± 0.0001	–	–	Derrick-Roberts et al. ⁴⁸
EF-1 α	MPS IIIA 1.5–1.6 mo	6 mo	ICV	NP	–	–	–	–	1.38 ± 0.94	–	–	–	McIntyre et al. ³¹

(Continued on next page)

Table 2. Continued

Promoter	Disease/ age	Time	ADM	Dose	Vector copy number/cell								Ref.
					Liver	Spleen	Heart	Kidney	Brain	Lung	BM	WBC	
<i>Ex vivo</i>													
SFFV	MPS IIIA 2 mo	4 mo	IV	2.5×10^5 cells ^a	–	–	–	–	–	–	–	0.23 ± 0.01	Langford-Smith et al. ⁹
SFFV	Pompe 1.5–3 mo	7 mo	IV	5×10^5 cells	–	–	–	–	–	–	3.65 ± 1.8	–	van Til et al. ⁷¹
SFFV	Pompe 1.5–2.0 mo	12 mo	IV	5×10^5 cells	–	3.5 ± 1.3	–	–	–	–	–	–	Stok et al. ⁷⁰
CD68	Gaucher 5–8 mo	1 mo	IV	NP	–	–	–	–	–	–	1.2 ± 0.5	–	Dahl et al. ³⁷
PGK	Gaucher 5–8 mo	1 mo	IV	NP	–	–	–	–	–	–	2 ± 1	–	
PGK	MPS IIIA 2 mo	6 mo	IV	NP	–	–	–	–	–	–	0.5 ± 0.3	–	Sergijenko et al. ⁷⁷
CD11b	MPS IIIA 2 mo	6 mo	IV	NP	–	–	–	–	–	–	1.2 ± 0.5	–	
CD11b	MPS II 1.5–2.0 mo	4 mo	IV	$3\text{--}4 \times 10^5$ cells	–	1.5 ± 1	–	–	0.0002 ± 0.0001	–	2 ± 1	1 ± 0.5	Gleitz et al. ⁷⁶
CD11b	MPS IIIA 1.5–2.0 mo	3 mo	IV	3×10^5 cells	–	–	–	–	ND	–	0.4 ± 0.1	0.55 ± 0.1	Ellison et al. ⁸¹
CD11b	MPS IIIA 1.5–2.0 mo	4 mo	IV	3×10^5 cells	1 ± 0.5	2 ± 0.5	–	–	0.25 ± 0.01	–	1.5 ± 0.5	2 ± 0.5	Parker et al. ⁷⁸
CD11b	MPS IIIB 2 mo	6 mo	IV	3×10^5 cells	0.5 ± 0.25	5 ± 1.5	–	–	0.025 ± 0.01	–	1.5 ± 0.5	2.5 ± 1	Holley et al. ⁷⁹
MCU3	MPS II 2.0–2.5 mo	6 mo	IV	2×10^6 cells	0.045 ± 0.02	–	–	–	0.0063 ± 0.001	–	–	–	Wakabayashi et al. ⁶²
MCU3	MPS II 2 mo	3 mo	IV	1.25×10^6 cells	0.098 ± 0.001	1.131 ± 0.5	–	–	0.005 ± 0.001	–	–	–	Wada et al. ⁶⁴
MCU3	MPS II 2 mo	6 mo	IV	$6.6 \pm 0.8 \times 10^5$ cells	0.04 ± 0.01	0.7 ± 0.01	1.2 ± 0.3	0.03 ± 0.01	0.03 ± 0.001	4 ± 1	–	3 ± 1	Miwa et al. ⁶⁵
EF-1 α	Fabry 2.0–3.7 mo	3 mo	IV	1×10^6 cells	0.05 ± 0.01	0.275 ± 0.05	0.095 ± 0.05	0.025 ± 0.01	–	–	–	–	Huang et al. ⁵³
EF-1 α	Fabry 2.0–3.7 mo	6 mo	IV	1×10^6 cells	0.075 ± 0.01	0.225 ± 0.05	0.085 ± 0.1	0.035 ± 0.1	–	–	–	–	

ADM, administration; BM, bone marrow; ICV, intracerebroventricular; IV, intravenous; ND, not detectable; NP, information not provided; WBC, White blood cells.

^aMouse hematopoietic stem cell transduced with a lentiviral vector.

experimental articles. We have also searched the clinical trials via <https://clinicaltrials.gov/>.

ACKNOWLEDGMENTS

Supported by grants from the National MPS Society Research Grant, Austrian MPS society, The Carol Ann Foundation, Angelo R. Cali & Mary V. Cali Family Foundation, Inc., The Vain and Harry Fish Foundation, Inc., The Bennett Foundation, Jacob Randall Foundation, and Nemours Funds. S.T. was supported by an Institutional Development Award from the National Institute of General Medical Sciences of the National Institutes of Health (grant nos. P30GM114736 and 1R01HD065767). The content of the article was not influenced by the sponsors.

AUTHOR CONTRIBUTIONS

E.R. conceptualization, writing - original draft and editing, visualization, data collection, figures and tables preparation; T.H., H.K., G.W. and D.S.G. review and comments; S.T. writing - review and editing, supervision.

DECLARATION OF INTERESTS

The authors declare no conflict of interest.

REFERENCES

- Platt, F.M., d'Azzo, A., Davidson, B.L., Neufeld, E.F., and Tiff, C.J. (2018). Lysosomal storage diseases. *Nat. Rev. Dis. Primers* 4, 27.
- Beck, M. (2018). Treatment strategies for lysosomal storage disorders. *Dev. Med. Child Neurol.* 60, 13–18.
- Neufeld, E.F. (1980). The uptake of enzymes into lysosomes: an overview. *Birth Defects Orig. Artic. Ser.* 16, 77–84.
- Sun, H., Yang, M., Haskins, M.E., Patterson, D.F., and Wolfe, J.H. (1999). Retrovirus vector-mediated correction and cross-correction of lysosomal alpha-mannosidase deficiency in human and feline fibroblasts. *Hum. Gene Ther.* 10, 1311–1319.
- Graceffa, V. (2020). Clinical development of cell therapies to halt lysosomal storage diseases: results and lessons learned. *Curr Gene Ther.* <https://doi.org/10.2174/1566523221666210728141924>.
- Kornfeld, S. (1990). Lysosomal enzyme targeting. *Biochem. Soc. Trans.* 18, 367–374.
- Li, M. (2018). Enzyme replacement therapy: a review and its role in treating lysosomal storage diseases. *Pediatr. Ann.* 47, e191–e197.
- Kanters, T.A., van der Ploeg, A.T., Kruijshaar, M.E., Rizopoulos, D., Redekop, W.K., Rutten-van Mölken, M.P.M.H., and Hakkaart-van Roijen, L. (2017). Cost-effectiveness of enzyme replacement therapy with alglucosidase alfa in adult patients with Pompe disease. *Orphanet J. Rare Dis.* 12, 179.
- Langford-Smith, A., Wilkinson, F.L., Langford-Smith, K.J., Holley, R.J., Sergijenko, A., Howe, S.J., Bennett, W.R., Jones, S.A., Wraith, J., Merry, C.L., et al. (2012). Hematopoietic stem cell and gene therapy corrects primary neuropathology and behavior in mucopolysaccharidosis IIIA mice. *Mol. Ther.* 20, 1610–1621.
- Ramachandran, V., Kolli, S.S., and Strowd, L.C. (2019). Review of graft-versus-host disease. *Dermatol. Clin.* 37, 569–582.
- Elmonem, M.A., Veys, K., Oliveira Arcolino, F., van Dyck, M., Benedetti, M.C., Diomedi-Camassei, F., de Hertogh, G., van den Heuvel, L.P., Renard, M., and Levchenko, E. (2018). Allogeneic HSCT transfers wild-type cystinosis to nonhematological epithelial cells in cystinosis: first human report. *Am. J. Transplant.* 18, 2823–2828.
- Nagree, M.S., Scalia, S., McKillop, W.M., and Medin, J.A. (2019). An update on gene therapy for lysosomal storage disorders. *Expert Opin. Biol. Ther.* 19, 655–670.
- Aubourg, P. (2016). Gene therapy for rare central nervous system diseases comes to age. *Endocr. Dev.* 30, 141–146.
- Zaiss, A., and Muruve, D. (2005). Immune responses to adeno-associated virus vectors. *Curr. Gene Ther.* 5, 323–331.
- Aronson, S.J., Veron, P., Collaud, F., Hubert, A., Delahais, V., Honnet, G., de Knecht, R.J., Junge, N., Baumann, U., di Giorgio, A., et al. (2019). Prevalence and relevance of pre-existing anti-adeno-associated virus immunity in the context of gene therapy for crigler-Najjar syndrome. *Hum. Gene Ther.* 30, 1297–1305.
- Louis Jeune, V., Joergensen, J.A., Hajjar, R.J., and Weber, T. (2013). Pre-existing anti-adeno-associated virus antibodies as a challenge in AAV gene therapy. *Hum. Gene Ther. Methods* 24, 59–67.
- Yuan, Z., Pastoriza, J., Quinn, T., and Libutti, S.K. (2014). Targeting tumor vasculature using adeno-associated virus phage vectors coding tumor Necrosis factor- α . In *Gene Therapy of Cancer*, E.C. Lattime, R.R. Wood, and S.L. Gerson, eds. (Elsevier), pp. 19–33.
- Ulrich-Vinther, M. (2007). Gene therapy methods in bone and joint disorders. Evaluation of the adeno-associated virus vector in experimental models of articular cartilage disorders, periprosthetic osteolysis and bone healing. *Acta Orthop. Suppl.* 78, 1–64.
- Dull, T., Zufferey, R., Kelly, M., Mandel, R.J., Nguyen, M., Trono, D., and Naldini, L. (1998). A third-generation lentivirus vector with a conditional packaging system. *J. Virol.* 72, 8463–8471.
- Kobayashi, H., Carbonaro, D., Pepper, K., Petersen, D., Ge, S., Jackson, H., Shimada, H., Moats, R., and Kohn, D.B. (2005). Neonatal gene therapy of MPS I mice by intravenous injection of a lentiviral vector. *Mol. Ther.* 11, 776–789.
- Breger, L., Wettergren, E.E., Quintino, L., and Lundberg, C. (2016). Regulated Gene Therapy. In *Gene Therapy for Neurological Disorders. Methods in Molecular Biology*, vol 1382, F. Manfredsson, ed. (New York, NY: Humana Press). https://doi.org/10.1007/978-1-4939-3271-9_4.
- Arjmand, B., Larjani, B., Sheikh Hosseini, M., Payab, M., Gilany, K., Goodarzi, P., Parhizkar Roudsari, P., Amanollahi Baharvand, M., and Hoseini Mohammadi, N.S. (2020). The horizon of gene therapy in modern medicine: advances and challenges. *Adv. Exp. Med. Biol.* 1247, 33–64.
- Powell, S.K., Rivera-Soto, R., and Gray, S.J. (2015). Viral expression cassette elements to enhance transgene target specificity and expression in gene therapy. *Discov. Med.* 19, 49–57.
- Fraldi, A., Serafini, M., Sorrentino, N.C., Gentner, B., Aiuti, A., and Bernardo, M.E. (2018). Gene therapy for mucopolysaccharidoses: in vivo and ex vivo approaches. *Ital. J. Pediatr.* 44, 130.
- Mátraí, J., Chuah, M.K., and VandenDriessche, T. (2010). Recent advances in lentiviral vector development and applications. *Mol. Ther.* 18, 477–490.
- Chen, C., Yue, D., Lei, L., Wang, H., Lu, J., Zhou, Y., Liu, S., Ding, T., Guo, M., and Xu, L. (2018). Promoter-operating targeted expression of gene therapy in cancer: current stage and prospect. *Mol. Ther. Nucleic Acids* 11, 508–514.
- Hamaguchi, I., Woods, N.-B., Panagopoulos, I., Andersson, E., Mikkola, H., Fahlman, C., Zufferey, R., Carlsson, L., Trono, D., and Karlsson, S. (2000). Lentivirus vector gene expression during ES cell-derived hematopoietic development in vitro. *J. Virol.* 74, 10778–10784.
- Soda, Y., Tani, K., Li, X., Bai, Y., Cho, S., Futami, M., Chen, M., Kobayashi, S., Miyoshi, H., and Sumimoto, H. (2005). PGK and CMV promoters exert the strongest activity in lentiviral gene transduction of myeloid cells including mature neutrophils. *Mol. Ther.* 11, S42.
- Anson, D.S., McIntyre, C., Thomas, B., Koldej, R., Ranieri, E., Roberts, A., Clements, P.R., Dunning, K., and Byers, S. (2007). Lentiviral-mediated gene correction of mucopolysaccharidosis type IIIA. *Genet. Vaccin. Ther.* 5, 1.
- Lattanzi, A., Salvagno, C., Madera, C., Benedicenti, F., Morena, F., Kulik, W., Naldini, L., Montini, E., Martino, S., and Gritti, A. (2014). Therapeutic benefit of lentiviral-mediated neonatal intracerebral gene therapy in a mouse model of globoid cell leukodystrophy. *Hum. Mol. Genet.* 23, 3250–3268.
- McIntyre, C., Derrick-Roberts, A.L.K., Byers, S., and Anson, D.S. (2014). Correction of murine mucopolysaccharidosis type IIIA central nervous system pathology by intracerebroventricular lentiviral-mediated gene delivery. *J. Gene Med.* 16, 374–387.
- Weinholtz, C.A., and Castle, M.J. (2021). Intersectional targeting of defined neural circuits by adeno-associated virus vectors. *J. Neurosci. Res.* 99, 981–990.

33. Hofling, A.A., Devine, S., Vogler, C., and Sands, M.S. (2004). Human CD34+ hematopoietic progenitor cell-directed lentiviral-mediated gene therapy in a xenotransplantation model of lysosomal storage disease. *Mol. Ther.* 9, 856–865.
34. Visigalli, I., Delai, S., Politi, L.S., di Domenico, C., Cerri, F., Mrak, E., D'Isa, R., Ungaro, D., Stok, M., Sanvito, F., et al. (2010). Gene therapy augments the efficacy of hematopoietic cell transplantation and fully corrects mucopolysaccharidosis type I phenotype in the mouse model. *Blood* 116, 5130–5139.
35. Ungari, S., Montepeloso, A., Morena, F., Cocchiarella, F., Recchia, A., Martino, S., Gentner, B., Naldini, L., and Biffi, A. (2015). Design of a regulated lentiviral vector for hematopoietic stem cell gene therapy of globoid cell leukodystrophy. *Mol. Ther. Methods Clin. Dev.* 2, 15038.
36. Gentner, B., Visigalli, I., Hiramatsu, H., Lechman, E., Ungari, S., Giustacchini, A., Schira, G., Amendola, M., Quattrini, A., Martino, S., et al. (2010). Identification of hematopoietic stem cell-specific miRNAs enables gene therapy of globoid cell leukodystrophy. *Sci. Transl. Med.* 2, 58ra84.
37. Dahl, M., Doyle, A., Olsson, K., Månsson, J.-E., Marques, A.R.A., Mirzaian, M., Aerts, J.M., Ehinger, M., Rothe, M., Modlich, U., et al. (2015). Lentiviral gene therapy using cellular promoters cures type 1 Gaucher disease in mice. *Mol. Ther.* 23, 835–844.
38. Biffi, A. (2017). Hematopoietic stem cell gene therapy for storage disease: current and new indications. *Mol. Ther.* 25, 1155–1162.
39. Sessa, M., Lorioli, L., Fumagalli, F., Acquati, S., Redaelli, D., Baldoli, C., Canale, S., Lopez, I.D., Morena, F., Calabria, A., et al. (2016). Lentiviral haemopoietic stem-cell gene therapy in early-onset metachromatic leukodystrophy: an ad-hoc analysis of a non-randomised, open-label, phase 1/2 trial. *Lancet* 388, 476–487.
40. di Domenico, C., Napoli, D., di Reyero, E.G.Y., Lombardo, A., Naldini, L., and di Natale, P. (2006). Limited transgene immune response and long-term expression of human α -L-Iduronidase in young adult mice with mucopolysaccharidosis type I by liver-directed gene therapy. *Hum. Gene Ther.* 17, 1112–1121.
41. Kyosen, S.O., Iizuka, S., Kobayashi, H., Kimura, T., Fukuda, T., Shen, J., Shimada, Y., Ida, H., Eto, Y., and Ohashi, T. (2010). Neonatal gene transfer using lentiviral vector for murine Pompe disease: long-term expression and glycogen reduction. *Gene Ther.* 17, 521–530.
42. Ou, L., Przybilla, M.J., Koniar, B.L., and Whitley, C.B. (2016). Elements of lentiviral vector design toward gene therapy for treating mucopolysaccharidosis I. *Mol. Genet. Metab. Rep.* 8, 87–93.
43. Mizushima, S., and Nagata, S. (1990). pEF-BOS, a powerful mammalian expression vector. *Nucleic Acids Res.* 18, 5322.
44. Schlimgen, R., Howard, J., Wooley, D., Thompson, M., Baden, L.R., Yang, O.O., Christiani, D.C., Mostoslavsky, G., Diamond, D.v., Duane, E.G., et al. (2016). Risks associated with lentiviral vector exposures and prevention strategies. *J. Occup. Environ. Med.* 58, 1159–1166.
45. McAllister, R.G., Liu, J., Woods, M.W., Tom, S.K., Rupa, C.A., and Barr, S.D. (2014). Lentivector integration sites in ependymal cells from a model of metachromatic leukodystrophy: non-B DNA as a new factor influencing integration. *Mol. Ther. Nucleic Acids* 3, e187.
46. Bielicki, J., McIntyre, C., and Anson, D.S. (2010). Comparison of ventricular and intravenous lentiviral-mediated gene therapy for murine MPS VII. *Mol. Genet. Metab.* 101, 370–382.
47. Derrick-Roberts, A.L.K., Pyragius, C.E., Kaidonis, X.M., Jackson, M.R., Anson, D.S., and Byers, S. (2014). Lentiviral-mediated gene therapy results in sustained expression of β -glucuronidase for up to 12 Months in the gus mps/mps and up to 18 Months in the gus tm(L175F)sly mouse models of mucopolysaccharidosis type VII. *Hum. Gene Ther.* 25, 798–810.
48. Derrick-Roberts, A.L.K., Panir, K., Pyragius, C.E., Zarrinkalam, K.H., Atkins, G.J., and Byers, S. (2016). Reversal of established bone pathology in MPS VII mice following lentiviral-mediated gene therapy. *Mol. Genet. Metab.* 119, 249–257.
49. Clarke, L.A., and Hollak, C.E.M. (2015). The clinical spectrum and pathophysiology of skeletal complications in lysosomal storage disorders. *Best Pract. Res. Clin. Endocrinol. Metab.* 29, 219–235.
50. Walia, J.S., Neschadim, A., Lopez-Perez, O., Alayoubi, A., Fan, X., Carpentier, S., Madden, M., Lee, C.-J., Cheung, F., Jaffray, D.A., et al. (2011). Autologous transplantation of Lentivector/acid ceramidase-transduced hematopoietic cells in nonhuman primates. *Hum. Gene Ther.* 22, 679–687.
51. Schuh, K., Twardzik, T., Kneitz, B., Heyer, J., Schimpl, A., and Serfling, E. (1998). The interleukin 2 receptor α chain/CD25 promoter is a target for nuclear factor of activated T cells. *J. Exp. Med.* 188, 1369–1373.
52. Yoshimitsu, M., Higuchi, K., Ramsu, S., Nonaka, T., Rasaiah, V.I., Siatskas, C., Liang, S.-B., Murray, G.J., Brady, R.O., and Medin, J.A. (2007). Efficient correction of Fabry mice and patient cells mediated by lentiviral transduction of hematopoietic stem/progenitor cells. *Gene Ther.* 14, 256–265.
53. Huang, J., Khan, A., Au, B.C., Barber, D.L., López-Vásquez, L., Prokopishyn, N.L., Boutin, M., Rothe, M., Rip, J.W., Abaoui, M., et al. (2017). Lentivector iterations and pre-clinical scale-up/toxicity testing: targeting mobilized CD34+ cells for correction of Fabry disease. *Mol. Ther. Methods Clin. Dev.* 5, 241–258.
54. Khan, A., Barber, D.L., Huang, J., Rupa, C.A., Rip, J.W., Auray-Blais, C., Boutin, M., O'Hoski, P., Gargulak, K., McKillop, W.M., et al. (2021). Lentivirus-mediated gene therapy for Fabry disease. *Nat. Commun.* 12, 1178.
55. Elmonem, M.A., Veys, K.R., Soliman, N.A., van Dyck, M., van den Heuvel, L.P., and Levchenko, E. (2016). Cystinosis: a review. *Orphanet J. Rare Dis.* 11, 47.
56. Harrison, F., Yeagy, B.A., Rocca, C.J., Kohn, D.B., Salomon, D.R., and Cherqui, S. (2013). Hematopoietic stem cell gene therapy for the multisystemic lysosomal storage disorder cystinosis. *Mol. Ther.* 21, 433–444.
57. Astrakhan, A., Sather, B.D., Ryu, B.Y., Khim, S., Singh, S., Humblet-Baron, S., Ochs, H.D., Miao, C.H., and Rawlings, D.J. (2012). Ubiquitous high-level gene expression in hematopoietic lineages provides effective lentiviral gene therapy of murine Wiskott-Aldrich syndrome. *Blood* 119, 4395–4407.
58. Zufferey, R., Donello, J.E., Trono, D., and Hope, T.J. (1999). Woodchuck hepatitis virus posttranscriptional regulatory element enhances expression of transgenes delivered by retroviral vectors. *J. Virol.* 73, 2886–2892.
59. Hlavaty, J., Schittmayer, M., Stracke, A., Jandl, G., Knapp, E., Felber, B.K., Salmons, B., Günzburg, W.H., and Renner, M. (2005). Effect of posttranscriptional regulatory elements on transgene expression and virus production in the context of retrovirus vectors. *Virology* 341, 1–11.
60. Heldermon, C.D., Qin, E.Y., Ohlemiller, K.K., Herzog, E.D., Brown, J.R., Vogler, C., Hou, W., Orrock, J.L., Crawford, B.E., and Sands, M.S. (2013). Disease correction by combined neonatal intracranial AAV and systemic lentiviral gene therapy in Sanfilippo Syndrome type B mice. *Gene Ther.* 20, 913–921.
61. Wang, J., Lozier, J., Johnson, G., Kirshner, S., Verthelyi, D., Pariser, A., Shores, E., and Rosenberg, A. (2008). Neutralizing antibodies to therapeutic enzymes: considerations for testing, prevention and treatment. *Nat. Biotechnol.* 26, 901–908.
62. Wakabayashi, T., Shimada, Y., Akiyama, K., Higuchi, T., Fukuda, T., Kobayashi, H., Eto, Y., Ida, H., and Ohashi, T. (2015). Hematopoietic stem cell gene therapy corrects neuropathic phenotype in murine model of mucopolysaccharidosis type II. *Hum. Gene Ther.* 26, 357–366.
63. Stevenson, D.A., Rudser, K., Kunin-Batson, A., Fung, E.B., Viskochil, D., Shapiro, E., Orchard, P.J., Whitley, C.B., and Polgreen, L.E. (2014). Biomarkers of bone remodeling in children with mucopolysaccharidosis types I, II, and VI. *J. Pediatr. Rehabil. Med.* 7, 159–165.
64. Wada, M., Shimada, Y., Iizuka, S., Ishii, N., Hiraki, H., Tachibana, T., Maeda, K., Saito, M., Arakawa, S., Ishimoto, T., et al. (2020). Ex vivo gene therapy treats bone complications of mucopolysaccharidosis type II mouse models through bone remodeling reactivation. *Mol. Ther. Methods Clin. Dev.* 19, 261–274.
65. Miwa, S., Watabe, A.M., Shimada, Y., Higuchi, T., Kobayashi, H., Fukuda, T., Kato, F., Ida, H., and Ohashi, T. (2020). Efficient engraftment of genetically modified cells is necessary to ameliorate central nervous system involvement of murine model of mucopolysaccharidosis type II by hematopoietic stem cell targeted gene therapy. *Mol. Genet. Metab.* 130, 262–273.
66. Ogawa, R., Morii, A., Watanabe, A., Cui, Z.-G., Kagiya, G., Fukuda, S., Kume, K., Hasegawa, T., Hatashita, M., Izumi, H., et al. (2013). Development of a therapeutically important radiation induced promoter. *Bioengineered* 4, 44–49.
67. Chastel, C., Jiricny, J., and Jaussi, R. (2004). Activation of stress-responsive promoters by ionizing radiation for deployment in targeted gene therapy. *DNA Repair* 3, 201–215.

68. Ogawa, R., Morii, A., Watanabe, A., Cui, Z.-G., Kagiya, G., Fukuda, S., Kume, K., Hasegawa, T., Hatashita, M., Izumi, H., et al. (2012). Regulation of gene expression in retrovirus vectors by X-ray and proton beam radiation with artificially constructed promoters. *J. Gene Med.* *14*, 316–327.
69. Marples, B., Scott, S.D., Hendry, J.H., Embleton, M.J., Lashford, L.S., and Margison, G.P. (2000). Development of synthetic promoters for radiation-mediated gene therapy. *Gene Ther.* *7*, 511–517.
70. Stok, M., de Boer, H., Huston, M.W., Jacobs, E.H., Roovers, O., Visser, T.P., Jahr, H., Duncker, D.J., van Deel, E.D., Reuser, A.J.J., et al. (2020). Lentiviral hematopoietic stem cell gene therapy corrects murine Pompe disease. *Mol. Ther. Methods Clin. Dev.* *17*, 1014–1025.
71. van Til, N.P., Stok, M., Aerts Kaya, F.S.F., de Waard, M.C., Farahbakhshian, E., Visser, T.P., Kroos, M.A., Jacobs, E.H., Willart, M.A., van der Wegen, P., et al. (2010). Lentiviral gene therapy of murine hematopoietic stem cells ameliorates the Pompe disease phenotype. *Blood* *115*, 5329–5337.
72. Yan, Z., Yan, H., and Ou, H. (2012). Human thyroxine binding globulin (TBG) promoter directs efficient and sustaining transgene expression in liver-specific pattern. *Gene* *506*, 289–294.
73. Jeyakumar, J., Kia, A., McIntosh, J., Verhoef, D., Kalcheva, P., Hosseini, P., Sheridan, R., Corbau, R., and Nathwani, A. (2019). Liver-directed gene therapy corrects Fabry disease in mice. *Mol. Genet. Metab.* *126*, S80.
74. Lee, C.-J., Fan, X., Guo, X., and Medin, J.A. (2011). Promoter-specific lentivectors for long-term, cardiac-directed therapy of Fabry disease. *J. Cardiol.* *57*, 115–122.
75. Dziennis, S., van Etten, R.A., Pahl, H.L., Morris, D.L., Rothstein, T.L., Bloch, C.M., Perlmutter, R.M., and Tenen, D.G. (1995). The CD11b promoter directs high-level expression of reporter genes in macrophages in transgenic mice. *Blood* *85*, 319–329.
76. Gleitz, H.F., Liao, A.Y., Cook, J.R., Rowston, S.F., Forte, G.M., D'Souza, Z., O'Leary, C., Holley, R.J., and Bigger, B.W. (2018). Brain-targeted stem cell gene therapy corrects mucopolysaccharidosis type II via multiple mechanisms. *EMBO Mol. Med.* *10*, e8730.
77. Sergijenko, A., Langford-Smith, A., Liao, A.Y., Pickford, C.E., McDermott, J., Nowinski, G., Langford-Smith, K.J., Merry, C.L., Jones, S.A., Wraith, J.E., et al. (2013). Myeloid/microglial driven autologous hematopoietic stem cell gene therapy corrects a Neuronopathic lysosomal disease. *Mol. Ther.* *21*, 1938–1949.
78. Parker, H., Ellison, S.M., Holley, R.J., O'Leary, C., Liao, A., Asadi, J., Glover, E., Ghosh, A., Jones, S., Wilkinson, F.L., et al. (2020). Haematopoietic stem cell gene therapy with <sc>IL</sc> -1Ra rescues cognitive loss in mucopolysaccharidosis <sc>IIIA</sc>. *EMBO Mol. Med.* *12*, e11185.
79. Holley, R.J., Ellison, S.M., Fil, D., O'Leary, C., McDermott, J., Senthivel, N., Langford-Smith, A.W.W., Wilkinson, F.L., D'Souza, Z., Parker, H., et al. (2018). Macrophage enzyme and reduced inflammation drive brain correction of mucopolysaccharidosis IIIB by stem cell gene therapy. *Brain* *141*, 99–116.
80. Aoyagi-Scharber, M., Crippen-Harmon, D., Lawrence, R., Vincelette, J., Yogalingam, G., Prill, H., Yip, B.K., Baridon, B., Vitelli, C., Lee, A., et al. (2017). Clearance of heparan sulfate and attenuation of CNS pathology by intracerebroventricular BMN 250 in Sanfilippo type B mice. *Mol. Ther. Methods Clin. Dev.* *6*, 43–53.
81. Ellison, S.M., Liao, A., Wood, S., Taylor, J., Youshani, A.S., Rowston, S., Parker, H., Armant, M., Biffi, A., Chan, L., et al. (2019). Pre-clinical safety and efficacy of lentiviral vector-mediated ex vivo stem cell gene therapy for the treatment of mucopolysaccharidosis IIIA. *Mol. Ther. Methods Clin. Dev.* *13*, 399–413.
82. Eichler, F., Duncan, C., Musolino, P.L., Orchard, P.J., de Oliveira, S., Thrasher, A.J., Armant, M., Dansereau, C., Lund, T.C., Miller, W.P., et al. (2017). Hematopoietic stem-cell gene therapy for cerebral adrenoleukodystrophy. *N. Engl. J. Med.* *377*, 1630–1638.
83. Rushton, P.J. (2016). What have we learned about synthetic promoter construction? *Methods Mol. Biol.* *1482*, 1–13.
84. Donello, J.E., Loeb, J.E., and Hope, T.J. (1998). Woodchuck hepatitis virus contains a tripartite posttranscriptional regulatory element. *J. Virol.* *72*, 5085–5092.
85. European Medicines Agency (2020). https://www.ema.europa.eu/en/documents/assessment-report/zynteglo-epar-public-assessment-report_en.pdf.
86. Schuessler-Lenz, M., Enzmann, H., and Vamvakas, S. (2020). Regulators' advice can make a difference: European Medicines agency approval of Zynteglo for beta thalassaemia. *Clin. Pharmacol. Ther.* *107*, 492–494.
87. Brunson, A., Keegan, T.H.M., Bang, H., Mahajan, A., Paulukonis, S., and Wun, T. (2017). Increased risk of leukemia among sickle cell disease patients in California. *Blood* *130*, 1597–1599.
88. Liu, K.-C., Lin, B.-S., Gao, A.-D., Ma, H.-Y., Zhao, M., Zhang, R., Yan, H.-H., Yi, X.-F., Lin, S.-J., Que, J.-W., et al. (2014). Integrase-deficient lentivirus: opportunities and challenges for human gene therapy. *Curr. Gene Ther.* *14*, 352–364.
89. Michelini, Z., Negri, D., and Cara, A. (2010). Integrase defective, nonintegrating lentiviral vectors. *Methods Mol. Biol.* *614*, 101–110.
90. Apolonia, L. (2020). The old and the new: prospects for non-integrating lentiviral vector technology. *Viruses* *12*, 1103.
91. Milone, M.C., and O'Doherty, U. (2018). Clinical use of lentiviral vectors. *Leukemia* *32*, 1529–1541.
92. Duvergé, A., and Negroni, M. (2020). Pseudotyping lentiviral vectors: when the clothes make the virus. *Viruses* *12*, 1311.
93. Seker Yilmaz, B., Davison, J., Jones, S.A., and Baruteau, J. (2021). Novel therapies for mucopolysaccharidosis type <sc>III</sc>. *J. Inherit. Metab. Dis.* *44*.
94. Vector Builder (2021). <https://en.vectorbuilder.com/resources/vector-component/promoter.html>.
95. Amrom, D., Andermann, F., and Andermann, E. (2015). Action myoclonus – renal failure syndrome. *Gene Rev.* 1993–2021, <https://www.ncbi.nlm.nih.gov/books/NBK333437>.
96. Enomaa, N., Danos, O., Peltonen, L., and Jalanko, A. (1995). Correction of deficient enzyme activity in a lysosomal storage disease, aspartylglucosaminuria, by enzyme replacement and retroviral gene transfer. *Hum. Gene Ther.* *6*, 723–731.
97. Bennett, M.J., and Hofmann, S.L. (1999). The neuronal ceroid-lipofuscinoses (Batten disease): a new class of lysosomal storage diseases. *J. Inherit. Metab. Dis.* *22*, 535–544.
98. Rosenberg, J.B., Chen, A., Kaminsky, S.M., Crystal, R.G., and Sondhi, D. (2019). Advances in the treatment of neuronal ceroid lipofuscinosis. *Expert Opin. Orphan Drugs* *7*, 473–500.
99. Oladipo, O., Rosenblatt, D.S., Watkins, D., Miousse, I.R., Sprietsma, L., Dietzen, D.J., and Shinawi, M. (2011). Cobalamin F disease detected by newborn screening and follow-up on a 14-year-old patient. *Pediatrics* *128*, e1636–e1640.
100. D'Souza, R.S., and Law, L. (2020). Danon Disease (Stat Pearls).
101. El-Abassi, R., Singhal, D., and England, J.D. (2014). Fabry's disease. *J. Neurol. Sci.* *344*, 5–19.
102. Koga, M. (1995). Farber's lipogranulomatosis. *Nihon Rinsho* *53*, 3009–3013.
103. Wolf, H., Damme, M., Stroobants, S., D'Hooge, R., Beck, H.C., Hermans-Borgmeyer, I., Lüllmann-Rauch, R., Dierks, T., and Lübke, T. (2016). A mouse model for fucosidosis recapitulates storage pathology and neurological features of the milder form of the human disease. *Dis. Models Mech.* *9*, 1015–1028.
104. Caciotti, A., Catarzi, S., Tonin, R., Lugli, L., Perez, C., Michelakakis, H., Mavridou, I., Donati, M., Guerrini, R., D'Azzo, A., et al. (2013). Galactosialidosis: review and analysis of CTSA gene mutations. *Orphanet J. Rare Dis.* *8*, 114.
105. Rosenbloom, B.E., and Weinreb, N.J. (2013). Gaucher disease: a comprehensive review. *Crit. Rev. Oncog.* *18*, 163–175.
106. Brunetti-Pierri, N., and Scaglia, F. (2008). GM1 gangliosidosis: review of clinical, molecular, and therapeutic aspects. *Mol. Genet. Metab.* *94*, 391–396.
107. Allende, M.L., Cook, E.K., Larman, B.C., Nugent, A., Brady, J.M., Golebiowski, D., Sena-Esteves, M., Tiff, C.J., and Proia, R.L. (2018). Cerebral organoids derived from Sandhoff disease-induced pluripotent stem cells exhibit impaired neurodifferentiation. *J. Lipid Res.* *59*, 550–563.
108. Cachon-Gonzalez, M.B., Zaccariotto, E., and Cox, T.M. (2018). Genetics and therapies for GM2 gangliosidosis. *Curr. Gene Ther.* *18*, 68–89.
109. Pastores, G.M. (2009). Krabbe disease: an overview. *Int. J. Clin. Pharmacol. Ther.* *47*, S75–S81.

110. van Rappard, D.F., Boelens, J.J., and Wolf, N.I. (2015). Metachromatic leukodystrophy: disease spectrum and approaches for treatment. *Best Pract. Res. Clin. Endocrinol. Metab.* *29*, 261–273.
111. Velho, R.V., Harms, F.L., Danyukova, T., Ludwig, N.F., Friez, M.J., Cathey, S.S., Filocamo, M., Tappino, B., Güneş, N., Tüysüz, B., et al. (2019). The lysosomal storage disorders mucopolipidosis type II, type III alpha/beta, and type III gamma: update on GNPTAB and GNPTG mutations. *Hum. Mutat.* *40*, 842–864.
112. Muenzer, J. (2011). Overview of the mucopolysaccharidoses. *Rheumatology* *50*, v4–12.
113. Schlotawa, L., Adang, L.A., Radhakrishnan, K., and Ahrens-Nicklas, R.C. (2020). Multiple sulfatase deficiency: a disease comprising mucopolysaccharidosis, sphingolipidosis, and more caused by a defect in posttranslational modification. *Int. J. Mol. Sci.* *21*, 3448.
114. Vanier, M.T. (2013). Niemann-Pick diseases. *Handb Clin. Neurol.* *113*, 1717–1721.
115. Kohler, L., Puertollano, R., and Raben, N. (2018). Pompe disease: from basic science to therapy. *Neurotherapeutics* *15*, 928–942.
116. Sakuraba, H., Matsuzawa, F., Aikawa, S., Doi, H., Kotani, M., Nakada, H., Fukushige, T., and Kanzaki, T. (2004). Structural and immunocytochemical studies on α -N-acetylgalactosaminidase deficiency (Schindler/Kanzaki disease). *J. Hum. Genet.* *49*, 1–8.
117. Mancini, G.M.S., Verheijen, F.W., Beerens, C.E.M.T., Renlund, M., and Aula, P. (1991). Sialic acid storage disorders: observations on clinical and biochemical variation. *Dev. Neurosci.* *13*, 327–330.
118. Krivit, W., Freese, D., Chan, K.W., and Kulkarni, R. (1995). Wolman's disease: a review of treatment with bone marrow transplantation and considerations for the future. *Bone Marrow Transplant.* *10*, 97–101.
119. Pahl, H.L., Rosmarin, A.G., and Tenen, D.G. (1992). Characterization of the myeloid-specific CD11b promoter. *Blood* *79*, 865–870.
120. Pinkert, C.A., Ornitz, D.M., Brinster, R.L., and Palmiter, R.D. (1987). An albumin enhancer located 10 kb upstream functions along with its promoter to direct efficient, liver-specific expression in transgenic mice. *Genes Dev.* *1*, 268–276.
121. Subramaniam, A., Jones, W.K., Gulick, J., Wert, S., Neumann, J., and Robbins, J. (1991). Tissue-specific regulation of the alpha-myosin heavy chain gene promoter in transgenic mice. *J. Biol. Chem.* *266*, 24613–24620.
122. Huang, C.J., Tu, C.T., Hsiao, C.D., Hsieh, F.J., and Tsai, H.J. (2003). Germ-line transmission of a myocardium-specific GFP transgene reveals critical regulatory elements in the cardiac myosin light chain 2 promoter of zebrafish. *Dev. Dyn.* *22*, 30–40.
123. Ablain, J., Durand, E.M., Yang, S., Zhou, Y., and Zon, L.I. (2015). A CRISPR/Cas9 vector system for tissue-specific gene disruption in zebrafish. *Dev. Cell* *32*, 756–764.
124. Prasad, K.M., Xu, Y., Yang, Z., Acton, S.T., and French, B.A. (2011). Robust cardiomyocyte-specific gene expression following systemic injection of AAV: in vivo gene delivery follows a Poisson distribution. *Gene Ther.* *18*, 43–52.
125. Lin, Z., von Gise, A., Zhou, P., Gu, F., Ma, Q., Jiang, J., Yau, A.L., Buck, J.N., Gouin, K.A., van Gorp, P.R., et al. (2014). Cardiac-specific YAP activation improves cardiac function and survival in an experimental murine MI model. *Circ. Res.* *115*, 354–363.
126. Boshart, M., Weber, F., Jahn, G., Dorsch-Häsler, K., Fleckenstein, B., and Schaffner, W. (1985). A very strong enhancer is located upstream of an immediate early gene of human cytomegalovirus. *Cell* *41*, 521–530.
127. Qin, J.Y., Zhang, L., Clift, K.L., Hular, I., Xiang, A.P., Ren, B.Z., and Lahn, B.T. (2010). Systematic comparison of constitutive promoters and the doxycycline-inducible promoter. *PLoS One* *5*, e10611.
128. Adra, C.N., Boer, P.H., and McBurney, M.W. (1987). Cloning and expression of the mouse pgk-1 gene and the nucleotide sequence of its promoter. *Gene* *60*, 65–74.
129. Baum, C., Hegewisch-Becker, S., Eckert, H.G., Stocking, C., and Ostertag, W. (1995). Novel retroviral vectors for efficient expression of the multidrug resistance (mdr-1) gene in early hematopoietic cells. *J. Virol.* *69*, 7541–7547.
130. Demaison, C., Parsley, K., Brouns, G., Scherr, M., Battmer, K., Kinnon, C., Grez, M., and Thrasher, A.J. (2002). High-level transduction and gene expression in hematopoietic repopulating cells using a human immunodeficiency [correction of immunodeficiency] virus type 1-based lentiviral vector containing an internal spleen focus forming virus promoter. *Hum. Gene Ther.* *13*, 803–813.
131. Gray, S.J., Foti, S.B., Schwartz, J.W., Bachaboina, L., Taylor-Blake, B., Coleman, J., Ehlers, M.D., Zylka, M.J., McCown, T.J., and Samulski, R.J. (2011). Optimizing promoters for recombinant adeno-associated virus-mediated gene expression in the peripheral and central nervous system using self-complementary vectors. *Hum. Gene Ther.* *22*, 1143–1153.