

EDGE ARTICLE

Cite this: *Chem. Sci.*, 2021, 12, 12419

All publication charges for this article have been paid for by the Royal Society of Chemistry

Received 20th July 2021
Accepted 13th August 2021

DOI: 10.1039/d1sc03958j

rsc.li/chemical-science

The power of trichlorosilylation: isolable trisilylated allyl anions, allyl radicals, and allenyl anions†

Isabelle Georg,^a Markus Bursch,^b Burkhard Endeward,^c Michael Bolte,^a Hans-Wolfram Lerner,^a Stefan Grimme^b and Matthias Wagner^{*a}

Treatment of hexachloropropene ($\text{Cl}_2\text{C}=\text{C}(\text{Cl})-\text{CCl}_3$) with Si_2Cl_6 and $[n\text{Bu}_4\text{N}]\text{Cl}$ (1 : 4 : 1) in CH_2Cl_2 results in a quantitative conversion to the trisilylated, dichlorinated allyl anion salt $[n\text{Bu}_4\text{N}][\text{Cl}_2\text{C}=\text{C}(\text{SiCl}_3)-\text{C}(\text{SiCl}_3)_2]$ ($[n\text{Bu}_4\text{N}][\mathbf{1}]$). Tetrachloroallene $\text{Cl}_2\text{C}=\text{C}=\text{CCl}_2$ was identified as the first intermediate of the reaction cascade. In the solid state, $[\mathbf{1}]^-$ adopts approximate C_s symmetry with a dihedral angle between the planes running through the olefinic and carbanionic fragments of $[\mathbf{1}]^-$ of $\text{C}=\text{C}-\text{Si}//\text{Si}-\text{C}-\text{Si} = 78.3(1)^\circ$. One-electron oxidation of $[n\text{Bu}_4\text{N}][\mathbf{1}]$ with SbCl_5 furnishes the distillable blue radical $\mathbf{1}^\cdot$. The neutral propene $\text{Cl}_2\text{C}=\text{C}(\text{SiCl}_3)-\text{C}(\text{SiCl}_3)_2\text{H}$ ($\mathbf{2}$) was obtained by (i) protonation of $[\mathbf{1}]^-$ with HOSO_2CF_3 (HOTf) or (ii) H-atom transfer to $\mathbf{1}^\cdot$ from 1,4-cyclohexadiene. Quantitative transformation of all three SiCl_3 substituents in $\mathbf{2}$ to $\text{Si}(\text{OMe})_3$ (2^{OMe}) or SiMe_3 (2^{Me}) substituents was achieved by using $\text{MeOH}/\text{NMe}_2\text{Et}$ or MeMgBr in CH_2Cl_2 or THF, respectively. Upon addition of 2 equiv. of $t\text{BuLi}$, 2^{Me} underwent deprotonation with subsequent LiCl elimination, 1,2- SiMe_3 migration and Cl/Li exchange to afford the allenyl lithium compound $\text{Me}_3\text{Si}(\text{Li})\text{C}=\text{C}=\text{C}(\text{SiMe}_3)_2$ ($\text{Li}[\mathbf{4}]$), which is an efficient building block for the introduction of Me , SiMe_3 , or SnMe_3 ($\mathbf{5}$) groups. The trisilylated, monochlorinated allene $\text{Cl}_3\text{Si}(\text{Cl})\text{C}=\text{C}=\text{C}(\text{SiCl}_3)_2$ ($\mathbf{6}$), was obtained from $[n\text{Bu}_4\text{N}][\mathbf{1}]$ through Cl^- -ion abstraction with AlCl_3 and rearrangement in CH_2Cl_2 ($\mathbf{1}^\cdot$ forms as a minor side product, likely because the system $\text{AlCl}_3/\text{CH}_2\text{Cl}_2$ can also act as a one-electron oxidant).

Introduction

Organosilanes are invaluable building blocks for advanced materials and multifaceted reagents for organic synthesis.¹ Characteristic of the first application area is that the Si atoms remain as essential, function-determining parts in the molecular scaffolds (e.g., luminescent siloles,² silsesquioxane cages,³ and silicone polymers^{4,5}). The opposite is true for the second application area, because the silyl groups are no longer present in the final products after they served to transfer the organic fragment (e.g., Peterson olefination,⁶ Hiyama-type C–C-coupling,⁷ or Tamao oxidation⁸). Especially allylsilanes, which combine the reactivity of alkenes and metal-allyl reagents, have been termed “one of the most important building blocks in modern organic synthesis” (cf. the Hosomi–Sakurai

allylation⁹).¹⁰ While a plethora of efficient routes to mono-silylated allyl systems have been elaborated so far,¹¹ higher silylated derivatives are still difficult to access, which is unfortunate since geminal disilyl compounds in particular can be involved in numerous synthetically useful transformations.¹²

We have recently disclosed that the inexpensive chlorinated hydrocarbons CCl_4 , $\text{Cl}_2\text{C}=\text{CCl}_2$, and $\text{Cl}_2\text{C}=\text{C}(\text{Cl})-\text{C}(\text{Cl})=\text{CCl}_2$ can be straightforwardly converted to the exhaustively trichlorosilylated anions $[\text{A}]^- - [\text{C}]^{2-}$ upon treatment with Si_2Cl_6 in the presence of $[n\text{Bu}_4\text{N}]\text{Cl}$ (Scheme 1).^{13–15} The actual active silylation reagent, the silanide $[\text{SiCl}_3]^-$,^{16–18} is generated by Cl^- -induced heterolysis of the disilane. $[\text{SiCl}_3]^-$ can either react as a nucleophile in a carbophilic or chlorophilic attack (abstraction of a chloronium ion to form SiCl_4 and a carbanion), or behave as a Cl^- -stabilized dichlorosilylene $[\text{SiCl}_2 \cdot \text{Cl}]^-$.^{13,16,18,19} The primary products, $[\text{A}]^- - [\text{C}]^{2-}$, have been further transformed into a variety of other multiply trichlorosilylated compounds with geminally and/or vicinally positioned SiCl_3 substituents ($[\text{A} \cdot \text{GaCl}_3]^- - \text{E}$; Scheme 1).^{13–15} An SiCl_3 group differs from the more abundant SiMe_3 group in a number of ways: (i) the Si–Cl bonds offer the possibility of extensive derivatizations, such as transformation to Si–H bonds, alkylation, or hydrolysis to (oligo)siloxanes. (ii) SiCl_3 substituents are the better π acceptors and have a greater ability to stabilize adjacent carbanions (α effect).⁴ (iii) SiCl_3 substituents are the

^aInstitut für Anorganische und Analytische Chemie, Goethe-Universität Frankfurt, Max-von-Laue-Straße 7, D-60438 Frankfurt (Main), Germany. E-mail: matthias.wagner@chemie.uni-frankfurt.de

^bMulliken Center for Theoretical Chemistry, Institut für Physikalische und Theoretische Chemie, Universität Bonn, Beringstraße 4, 53115 Bonn, Germany

^cInstitut für Physikalische und Theoretische Chemie, Goethe-Universität Frankfurt, Max-von-Laue-Str. 7, D-60438 Frankfurt (Main), Germany

† Electronic supplementary information (ESI) available. CCDC 2078581. For ESI and crystallographic data in CIF or other electronic format see DOI: 10.1039/d1sc03958j



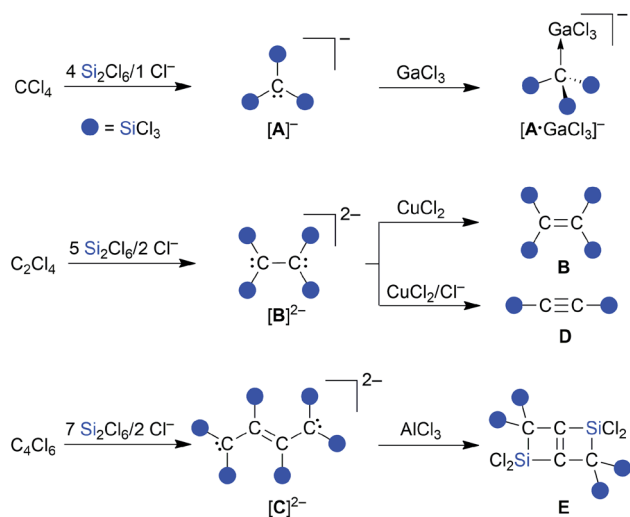

Scheme 1 Reactions of CCl_4 , C_2Cl_4 , or C_4Cl_6 with $\text{Si}_2\text{Cl}_6/\text{Cl}^-$ furnish the exhaustively trichlorosilylated carbanions $[\text{A}]^-$, $[\text{B}]^{2-}$, or $[\text{C}]^{2-}$, which give access to a variety of further compounds, such as the adduct $[\text{A}\cdot\text{GaCl}_3]^-$, the C_2 compounds **B** and **D**, and the strained, edge-fused double silacyclobutene **E**.

stronger Lewis acids. Analogous to the above-mentioned release of $[\text{SiCl}_3]^-$ from $\text{Si}_2\text{Cl}_6/\text{Cl}^-$, also other main-group anions $[\text{R}_n\text{E}]^-$ can readily be generated under mild conditions from precursor fragments $\text{R}_n\text{E}-\text{SiCl}_3$ upon addition of Lewis basic anions, such as F^- or Cl^- ($\text{E} = e.g., \text{C}, \text{Si}, \text{Ge}, \text{P}, \text{S}$).^{13,14,20–23}

Herein, we fill the gap in the series of perchlorinated substrates and report on the reaction of the C_3 substrate hexachloropropene (C_3Cl_6) with the $\text{Si}_2\text{Cl}_6/\text{Cl}^-$ system. In striking contrast to the previous cases (Scheme 1), there is now no quantitative Cl/SiCl_3 exchange, but we rather obtain selectively the trisilylated, dichlorinated allyl anion $[\mathbf{1}]^-$ (Scheme 2). One-electron oxidation of $[\mathbf{1}]^-$ affords the distillable blue radical $\mathbf{1}^\bullet$. Furthermore, we will show that $[\mathbf{1}]^-$ is a valuable starting material for the synthesis of multiply silylated C_3 products as diverse as propenes, cyclopropenes, and allenes.

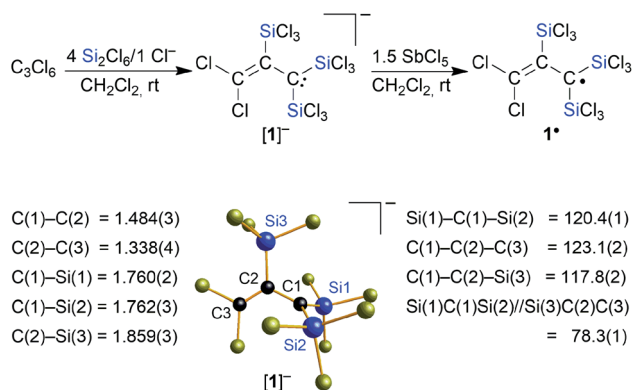

Scheme 2 Synthesis of $[\text{nBu}_4\text{N}][\mathbf{1}]$ from C_3Cl_6 and $\text{Si}_2\text{Cl}_6/[\text{nBu}_4\text{N}]\text{Cl}$; oxidation of $[\text{nBu}_4\text{N}][\mathbf{1}]$ with SbCl_5 generates the thermostable radical $\mathbf{1}^\bullet$. Molecular structure of $[\text{Ph}_4\text{P}][\mathbf{1}]$ in the solid state (the $[\text{Ph}_4\text{P}]^+$ cation is omitted for clarity); selected bond lengths [Å], bond angles [°], and dihedral angle [°].

Results and discussion

Synthesis and characterization of the mixed Cl/SiCl_3 -substituted allyl anion $[\mathbf{1}]^-$

Similar to the cases of $[\text{A}]^-$, $[\text{B}]^{2-}$, and $[\text{C}]^{2-}$, we initially aimed at the synthesis of a fivefold trichlorosilylated allyl anion $[\text{C}_3(\text{SiCl}_3)_5]^-$. To this end, we treated 1 equiv. of hexachloropropene (C_3Cl_6) with 6 equiv. of Si_2Cl_6 and 1 equiv. of $[\text{nBu}_4\text{N}]\text{Cl}$ in CH_2Cl_2 at room temperature; 5 equiv. of the disilane were supposed to provide the five SiCl_3 substituents, while the 6th equiv. was meant to formally abstract a Cl^+ cation and generate the negative charge. According to NMR spectroscopy, the reaction mixture contained no unconsumed C_3Cl_6 , no CH moieties, and one major organosilicon product that gave rise to three ^{13}C and two ^{29}Si resonances. Two of the ^{13}C resonances pointed toward the presence of an olefinic subunit ($\delta(^{13}\text{C}) = 135.8, 137.3$). The third ^{13}C NMR signal possessed a chemical shift value of 50.3 ppm, which is close to the value of the signal of the carbanionic centers in $[\text{C}]^{2-}$ (50.2 ppm).¹⁵ However, the total numbers of NMR signals were not consistent with a $[\text{C}_3(\text{SiCl}_3)_5]^-$ anion either of average C_{2v} or C_s symmetry. We also noted smaller ^{29}Si resonances characteristic of chloride diadducts of perchlorinated cyclohexasilanes (e.g. $[\text{Si}_6\text{Cl}_{12} \cdot 2\text{Cl}]^{2-}$), typically formed from $\text{Si}_2\text{Cl}_6/\text{Cl}^-$ mixtures in the absence of an additional reactant.^{16,18,19,24} Taken together, these observations led to the working hypothesis that the obtained product was a partly trichlorosilylated/chlorinated allyl anion. To substantiate this conclusion, we repeated the reaction with 4 equiv. of Si_2Cl_6 and obtained the same organosilicon product in a quantitative fashion and this time without the cyclohexasilane contaminants (NMR-spectroscopic control; 90% yield). An aliquot of the isolated product in CH_2Cl_2 was subsequently quenched with excess MeOH and titrated with aqueous NaOH. The amount of HCl released was determined to be 8 equiv., in agreement with three SiCl_3 substituents introduced (note that 1 equiv. of HCl is neutralized *in situ* by the carbanionic center). Instead of the aimed-for $[\text{nBu}_4\text{N}][\text{C}_3(\text{SiCl}_3)_5]$, a salt of the form $[\text{nBu}_4\text{N}][\text{C}_3(\text{SiCl}_3)_3\text{Cl}_2]$ had obviously been prepared ($[\text{nBu}_4\text{N}][\mathbf{1}]$; Scheme 2). Neither an increase in the amount of Si_2Cl_6 added (up to 17 equiv.) nor an elevated reaction temperature (refluxing CH_2Cl_2) enforced a higher degree of silylation, but only resulted in more cyclohexasilane side products.

Finally, X-ray crystallography confirmed the number of three SiCl_3 groups present in $[\mathbf{1}]^-$ and unequivocally revealed their positions at the C_3 chain: suitable single crystals of $[\text{Ph}_4\text{P}][\mathbf{1}]$ were obtained from a 1 : 4 : 1 mixture of C_3Cl_6 : Si_2Cl_6 : $[\text{Ph}_4\text{P}]\text{Cl}$ in CH_2Cl_2 (Scheme 2). All three carbon atoms of $[\mathbf{1}]^-$ have a planar configuration. C(1) and C(3) carry two SiCl_3 substituents and two Cl atoms, respectively; the third SiCl_3 substituent resides at C(2). The anion adopts an approximate C_s symmetry in the solid state with a dihedral angle $\text{Si}(1)\text{C}(1)\text{Si}(2)//\text{Si}(3)\text{C}(2)\text{C}(3)$ of $78.3(1)^\circ$. The C(1)–C(2) bond (1.484(3) Å) is even longer than that of the formal $\text{C}(\text{sp}^2)\text{--C}(\text{sp}^2)$ single bond in 1,3-butadiene (1.47 Å),²⁵ while the C(2)=C(3) bond length (1.338(4) Å) is typical of an isolated $\text{C}=\text{C}$ double bond (1.34 Å).²⁵ Any charge delocalization along the C_3 chain can obviously be neglected. Rather, the electron lone pair

(LP) at C(1) is stabilized by the α effect of the two attached SiCl_3 groups,⁴ which leads to a significant contraction of the C(1)–Si(1)/Si(2) bonds (1.760(2)/1.762(3) Å) compared to the C(2)–Si(3) bond (1.859(3) Å). The electronic structure of $[1]^-$ was further examined by quantum-chemical calculations at the $\omega\text{B97X-D3(BJ)}/\text{ma-def2-QZVPP}/\omega\text{B97X-D3(BJ)}/\text{ma-def2-TZVP}(\text{CPCM}(\text{CH}_2\text{Cl}_2))^{26}$ level (cf. the frontier orbitals shown in Fig. 1a). The range-separated hybrid functional was applied to avoid self-interaction error-related problems for anionic systems and too weakly bound electron density. A natural bond orbital (NBO)²⁷ analysis confirms a C(2)=C(3) double bond and a LP localized at the C(1) atom (Fig. 1b). C(1) bears a highly negative charge of $-1.60e^-$ and C(2) is also significantly negatively charged ($-0.53e^-$) while C(3)

is almost neutral ($-0.09e^-$). This trend is supported by a $\text{LP}(\text{C}(1)) \rightarrow \sigma^*(\text{C}(2)\text{--}\text{C}(3))$ charge-transfer stabilization estimate of $E^{(2)} = 10.3 \text{ kcal mol}^{-1}$. Strong charge-transfer estimates are further observed from $\text{LP}(\text{C}(1))$ into the antibonding C(2)–Si(3) ($E^{(2)} = 7.6 \text{ kcal mol}^{-1}$), Si(1)–Cl ($\Sigma E^{(2)} = 30.2 \text{ kcal mol}^{-1}$), and Si(2)–Cl ($\Sigma E^{(2)} = 29.5 \text{ kcal mol}^{-1}$) σ^* orbitals. Accordingly, charge transfer from the LP to the adjacent silyl groups is a crucial factor for the stabilization of $[1]^-$. In sum, repulsive but much smaller contributions are found for the interactions of the corresponding Si–C σ bonds with the C=C π (anti-)bond (3.1 and 3.6 kcal mol^{-1}). Nevertheless, the experimentally obtained isomer of $[1]^-$ is energetically disfavored relative to the isomer $[1']^-$ bearing a Cl atom at C(2) and a *trans*- SiCl_3 group at C(3) (with respect to C(1); Fig. 1c).

To gain some experimental insight into mechanistic details of the formation of $[1]^-$, we performed two NMR-scale experiments. Experiment 1: a mixture $\text{C}_3\text{Cl}_6 : \text{Si}_2\text{Cl}_6 : [\text{nBu}_4\text{N}]\text{Cl}$ (1 : 1 : 0.07) in CD_2Cl_2 was prepared at room temperature. After 1.5 h, when most of the C_3Cl_6 and Si_2Cl_6 had been consumed, NMR-spectroscopic investigation of the reaction mixture revealed tetrachloroallene (**F**)²⁸ and its dimer **G**²⁹ as the sole organic products (Scheme 3). Experiment 2: a solid mixture $\text{C}_3\text{Cl}_6 : \text{Si}_2\text{Cl}_6 : [\text{nBu}_4\text{N}]\text{Cl}$ (1 : 4 : 1) in CD_2Cl_2 was prepared at liquid-nitrogen temperature and allowed to melt inside the pre-cooled NMR spectrometer (-32°C). $^{13}\text{C}\{^1\text{H}\}$ NMR spectra were recorded at regular intervals of 28 min. During the first five intervals, the temperature of -32°C was maintained; later, the sample was slowly brought to room temperature (see the ESI† for full details). After the first interval, **F** was detected besides residual starting material C_3Cl_6 (Fig. 2). After the second interval, the resonances of $[1]^-$ had emerged, those of **F** were still visible and those of C_3Cl_6 had vanished. As the reaction progressed, the amount of **F** in the mixture steadily decreased while that of $[1]^-$ increased, until finally (at room temperature) only $[1]^-$ was present. The dimer **G** was not observed at any point in time. Two small ^{13}C resonances ($\delta = 182.2, 143.9$), which appeared together with the signals of $[1]^-$ and disappeared again at the end of the conversion may be assignable to an unknown intermediate (Fig. 2). Experiment 1 suggests an initial dechlorination of C_3Cl_6 *via* chloronium-ion abstraction by $[\text{SiCl}_3]^-$ to form SiCl_4 and **F/G** with concomitant release of Cl^- .³⁰ Two further conclusions can be drawn: (i) the activation barrier of the reaction $\text{C}_3\text{Cl}_6 \rightarrow \text{F}$ is even lower than that of the reaction $2 \text{F} \rightarrow \text{G}$,³¹ because **F** is replenished faster than it dimerizes to **G**. (ii) The overall barrier of the follow-up reaction $\text{F} \rightarrow [1]^-$ is higher than that of $\text{C}_3\text{Cl}_6 \rightarrow \text{F}$. Otherwise, the conversion $\text{C}_3\text{Cl}_6 \rightarrow \text{F}$ with only catalytic amounts of Cl^- could not proceed quantitatively because the formation of $[\text{nBu}_4\text{N}][1]$ traps 1 equiv. of $[\text{nBu}_4\text{N}]\text{Cl}$. The results of experiment 2 can be interpreted as follows: (i) also in the presence of 1 equiv. of Cl^- , **F** remains the primary intermediate of the reaction between C_3Cl_6 and Si_2Cl_6 and is generated already at low temperatures. (ii) When the stoichiometrically required amounts of $\text{Si}_2\text{Cl}_6/\text{Cl}^-$ are present, the reaction $\text{F} \rightarrow [1]^-$ runs to completion and the dimerization of **F** can no longer compete. (iii) Apart from **F**, no further intermediates are unequivocally identifiable by *in situ* NMR spectroscopy (but only the final product $[1]^-$). Therefore,

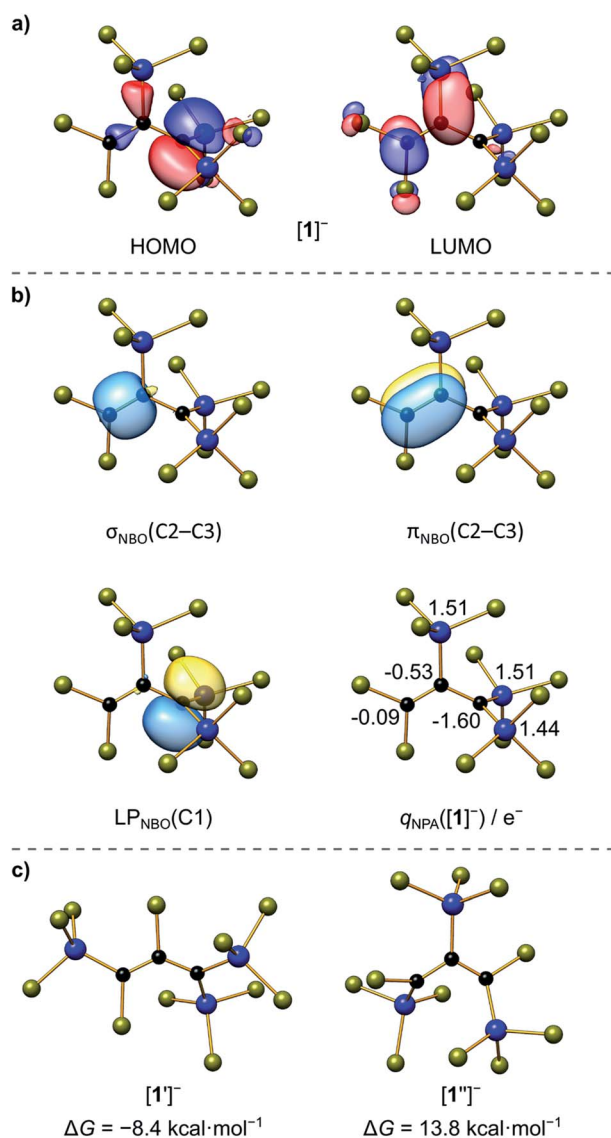
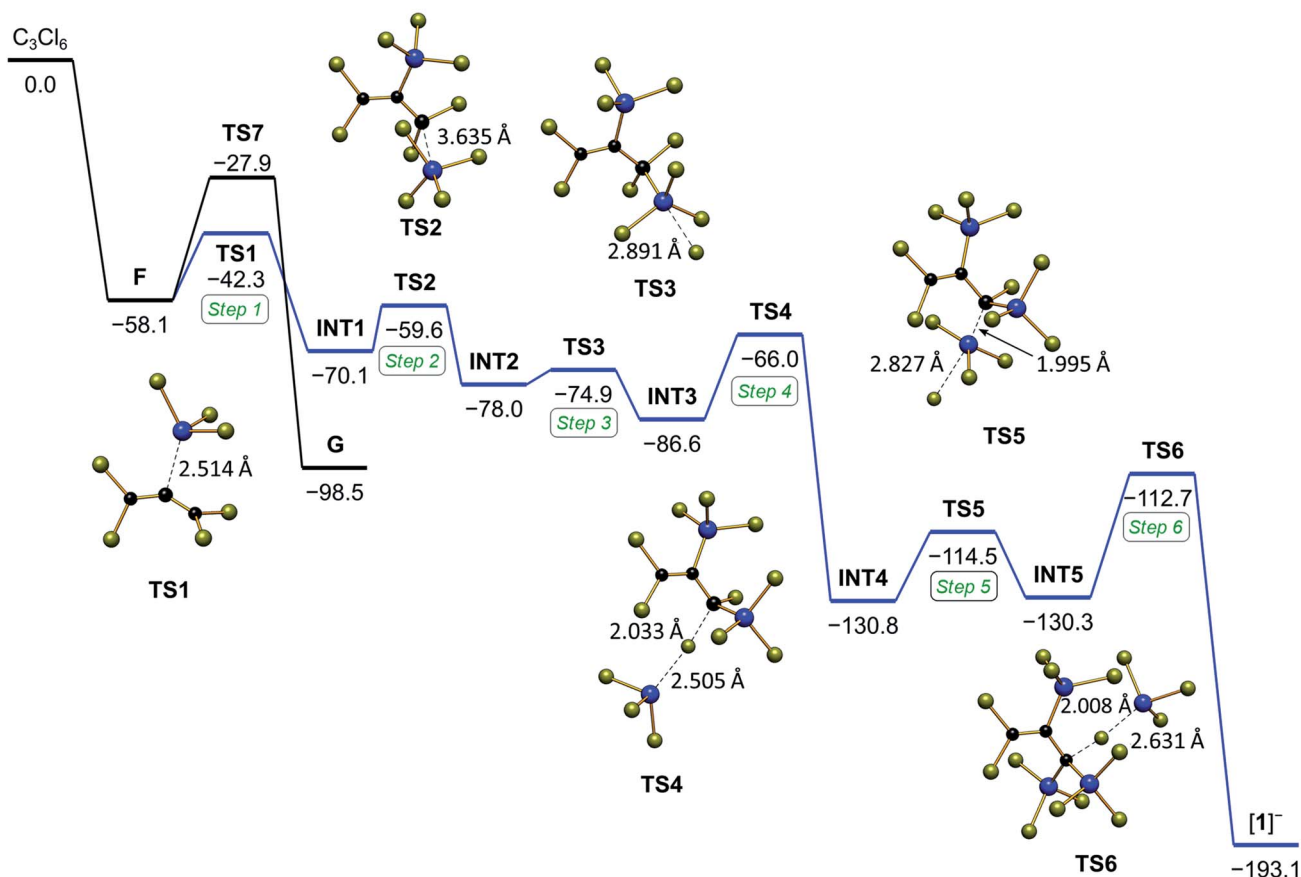
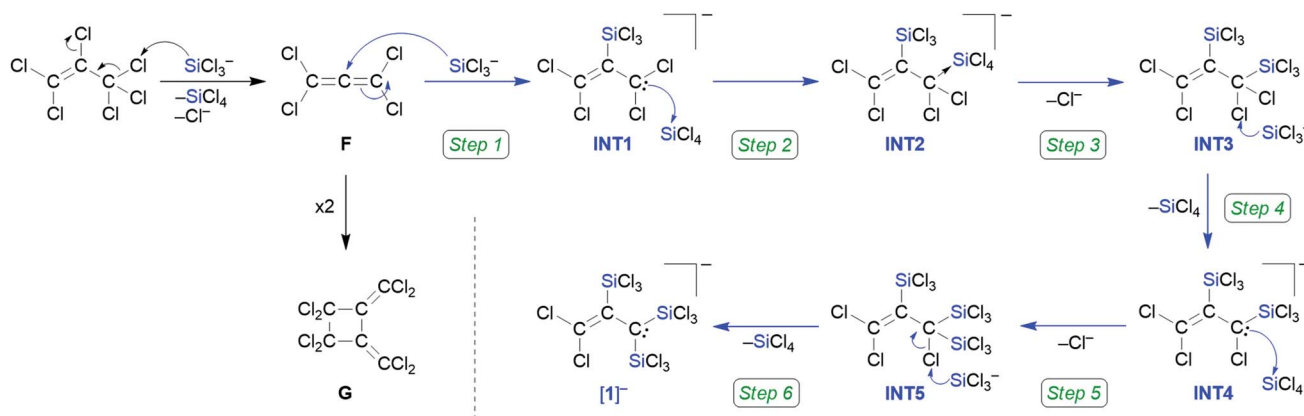

Fig. 1 (a) Selected Kohn–Sham molecular orbitals of $[1]^-$; (b) NBOs involved in the bonding of the C_3 chain (isosurface value = $0.05 e^{-1/2}$ Bohr $^{-3/2}$) and natural charges at the Si and C atoms; (c) Gibbs free energies relative to $[1]^-$ ($\Delta G = 0 \text{ kcal mol}^{-1}$) of isomers $[1']^-$ and $[1'']^-$ with different substitution patterns. Computed at the $\omega\text{B97X-D3(BJ)}/\text{ma-def2-QZVPP}/\omega\text{B97X-D3(BJ)}/\text{ma-def2-TZVP}(\text{CPCM}(\text{CH}_2\text{Cl}_2))$ level; see Scheme 2 for the atom numbering.



Scheme 3 Top: reaction of C₃Cl₆ with Si₂Cl₆ and Cl⁻ furnishes perchloroallene F, which can either dimerize to G (black pathway) or react further to [1]⁻ (blue pathway). Bottom: Gibbs free energy (kcal mol⁻¹) diagram for the formation of [1]⁻ computed at the ωB97X-D3(BJ)/ma-def2-QZVPP+COSMO-RS//ma-def2-TZVP(CPCM(CH₂Cl₂)) level of theory (standard conditions).

our mechanistic proposal for the formation of [1]⁻ has to be based on previous experiences with related systems and quantum-chemical calculations at the ωB97X-D3(BJ)/ma-def2-QZVPP+COSMO-RS^{32,33}//ma-def2-TZVP(CPCM(CH₂Cl₂)) level that fully support all the conclusions drawn (Scheme 3).³⁴

Step 1: we assume a nucleophilic attack of [SiCl₃]⁻ on the central carbon atom of F, which produces the allyl anion INT1. Step 2: INT1 and SiCl₄ form a pentacoordinated adduct INT2. Step 3: INT2 readily releases a Cl⁻ ion yielding the disilylated

prop-1-ene INT3. Step 4: chlorophilic attack of [SiCl₃]⁻ on a Cl-C(sp³) bond of INT3 generates the allyl anion INT4 (a similar chloronium-ion abstraction initiates also the reactions C₃Cl₆ → F and CCl₄ → [A]⁻ (Scheme 1)^{13,14,20}). Step 5: due to the α effect of the SiCl₃ substituent, the generated electron lone pair will preferentially reside on the silylated C-terminus, which straightforwardly explains why the third SiCl₃ group is attached at this position to give the neutral prop-1-ene INT5, even though this step is slightly endergonic. Step 6: a chlorophilic attack of

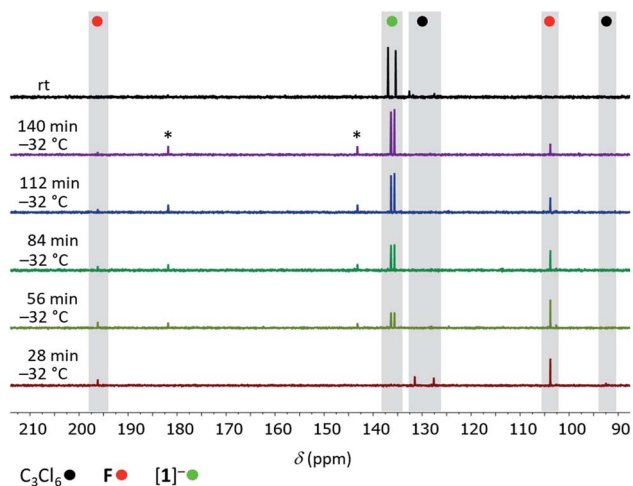

Fig. 2 $^{13}\text{C}\{^1\text{H}\}$ NMR spectra recorded at $-32\text{ }^\circ\text{C}$ at 28 min intervals on the reaction mixture $\text{C}_3\text{Cl}_6 : \text{Si}_2\text{Cl}_6 : [\text{nBu}_4\text{N}]\text{Cl}$ (1 : 4 : 1; CD_2Cl_2) and at room temperature (top); (*) unknown intermediate.

$[\text{SiCl}_3]^-$ on the remaining $\text{Cl}-\text{C}(\text{sp}^3)$ bond of **INT5** releases the product $[\mathbf{1}]^-$ and provides a huge thermodynamic driving force. The reaction likely stops at this stage for kinetic reasons, because $[\mathbf{1}]^-$ is already a sterically crowded compound: quantum-chemical calculations on the putative pentasilylated allyl anion $[\text{C}_3(\text{SiCl}_3)_5]^-$ show a highly strained structure, even though the reaction $[\mathbf{1}]^- + 2 [\text{SiCl}_3]^- \rightarrow [\text{C}_3(\text{SiCl}_3)_5]^- + 2 \text{Cl}^-$ is predicted to be exergonic by $\Delta G = -82 \text{ kcal mol}^{-1}$. The situation in hexasilylated $[\text{C}]^{2-}$ is different, since its two carbanionic termini adopt orthogonal conformations with respect to the central $\text{C}=\text{C}$ double bond, avoiding unfavorable vicinal $\text{SiCl}_3 \cdots \text{SiCl}_3$ interactions that should be a major issue in the case of $[\text{C}_3(\text{SiCl}_3)_5]^-$.

Targeted synthesis of the thermostable allyl radical $\mathbf{1}^\cdot$

Cyclic voltammetry on $[\text{nBu}_4\text{N}][\mathbf{1}]$ showed a (quasi)reversible redox wave with a half-wave potential of $E_{1/2} = 0.06 \text{ V}$ (vs. FcH/FcH^+ ; CH_2Cl_2 , supporting electrolyte: $[\text{nBu}_4\text{N}][\text{B}(\text{C}_6\text{F}_5)_4]$), indicating that the radical $\mathbf{1}^\cdot$ may be synthetically accessible (we found no indication of further oxidation of $\mathbf{1}^\cdot$ to the corresponding allyl cation $[\mathbf{1}]^+$). After an extensive screening of numerous oxidants, SbCl_5 was identified as the reagent of choice (for more detailed information on the oxidizing agents used and the respective reactions, see the ESI †):³⁵ when SbCl_5 was added at room temperature to a brown solution of $[\text{nBu}_4\text{N}][\mathbf{1}]$ in CH_2Cl_2 , the color immediately changed to green. After 5 min of stirring, *n*-hexane was added to precipitate all insoluble salts, the $\text{CH}_2\text{Cl}_2/\textit{n}$ -hexane mixture was evaporated, and the blue $\mathbf{1}^\cdot$ was distilled off (10^{-3} mbar , $90\text{ }^\circ\text{C}$; 78% yield, Scheme 2). The exceptional (thermal) stability of distillable $\mathbf{1}^\cdot$ under inert conditions stands out among most other organic radicals.³⁶ The identity of $\mathbf{1}^\cdot$ was proven by a quenching experiment with the H-atom donor 1,4-cyclohexadiene, which gave the corresponding prop-1-ene **2** (cf. Scheme 6) and C_6H_6 in a 2 : 1 ratio. An EPR spectrum, recorded at room temperature on a solution of $\mathbf{1}^\cdot$ in CH_2Cl_2 , is in good agreement with

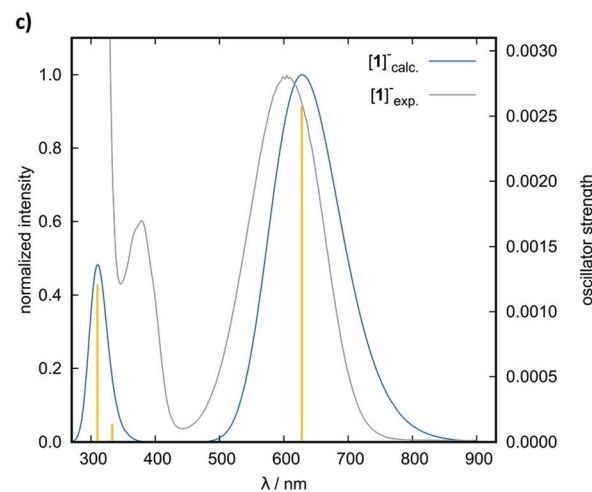
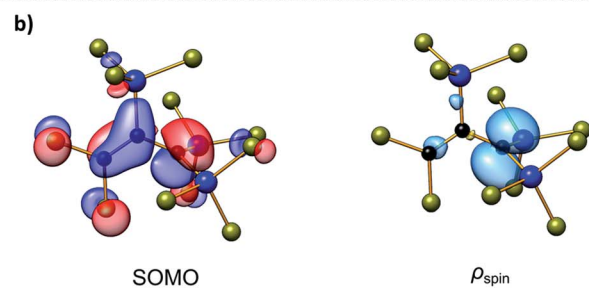
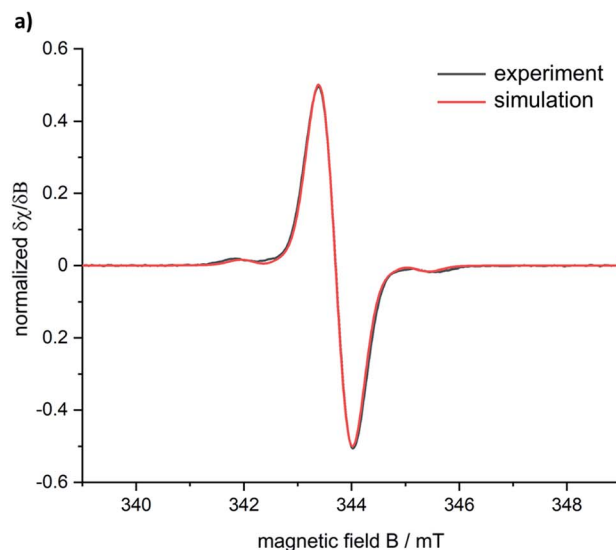
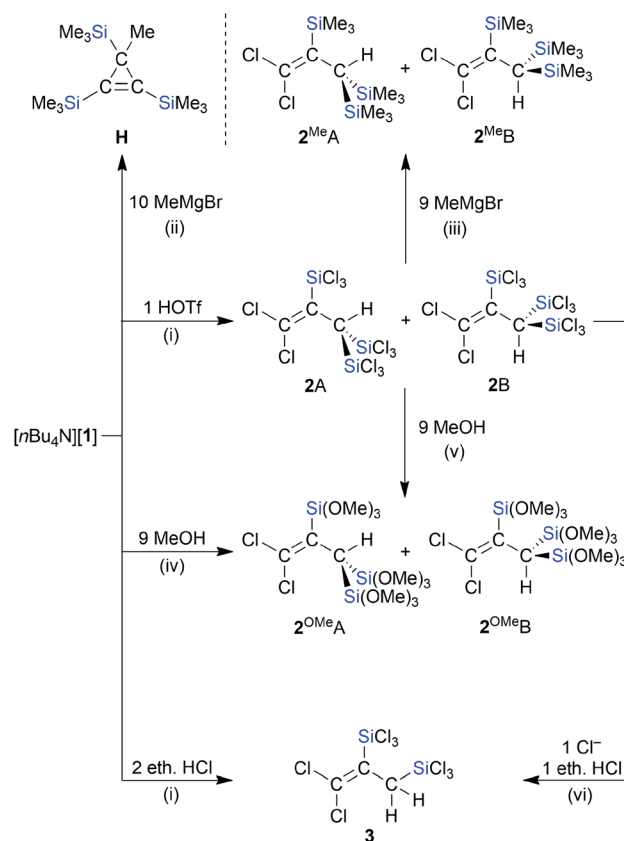

Fig. 3 (a) Experimental EPR spectrum of $\mathbf{1}^\cdot$ (black; 0.48 mM in CH_2Cl_2 , room temperature). Simulated EPR spectrum (red), based on the experimentally obtained g value of 2.0036 and computed hyperfine coupling constants (hfc) calculated at the $\omega\text{B97X-D3(BJ)}/\text{ma-def2-TZVP}(\text{CPCM}(\text{CH}_2\text{Cl}_2))$ level of theory: $1 \times a(^{13}\text{C}) = -8.8 \text{ G}$, $1 \times a(^{13}\text{C}) = 18.0 \text{ G}$, $1 \times a(^{13}\text{C}) = 27.8 \text{ G}$, $2 \times a(^{29}\text{Si}) = 14.1 \text{ G}$, $1 \times a(^{29}\text{Si}) = -29.3 \text{ G}$, $2 \times a(^{35}\text{Cl}/^{37}\text{Cl}) = 0.4 \text{ G}$, $3 \times a(^{35}\text{Cl}/^{37}\text{Cl}) = 0.7 \text{ G}$, $6 \times a(^{35}\text{Cl}/^{37}\text{Cl}) = 1.0 \text{ G}$; linewidth = 1.0 G. All exptl. hfc have been scaled by the respective gyromagnetic ratios and natural abundances using the program easyspin.³⁹ (b) Singly occupied Kohn-Sham molecular orbital (SOMO) and Mulliken spin-density plot of $\mathbf{1}^\cdot$. Isosurface values = $0.05 \text{ e}^{-1/2} \text{ Bohr}^{-3/2}$ (MOs) and $0.005 \text{ e Bohr}^{-1/2}$ (ρ_{spin}). (c) Normalized computed (blue), experimental (grey) UV/vis spectrum of $\mathbf{1}^\cdot$ and calculated transitions (yellow) at the TDA-DFT $\omega\text{B97X-D3(BJ)}/\text{ma-def2-TZVP}(\text{CPCM}(\text{CH}_2\text{Cl}_2))$ level, applying molecule-dependent optimal tuning.

a simulated spectrum obtained using the hyperfine coupling constants computed at the ω B97X-D3(BJ)/ma-def2-TZVP(CPCM(CH₂Cl₂)) level of theory (Fig. 3a). The singly occupied molecular orbital (SOMO) of **1**[•] is plotted in Fig. 3b; a corresponding spin-density plot shows that the odd electron is mainly localized in the p_z orbital of C(1). The blue color of **1**[•] arises from an absorption band at $\lambda_{\text{max}} = 605 \text{ nm}$ ($\epsilon = 11\,023 \text{ M}^{-1} \text{ cm}^{-1}$) in CH₂Cl₂, which is reasonably reproduced by quantum-chemical calculations applying the Tamm-Dancoff approximation of time-dependent DFT (TDA-DFT)³⁷ and molecule-dependent optimal tuning³⁸ (Fig. 3c; cf. [nBu₄N][B^{•-}]; $\lambda_{\text{max}} = 650 \text{ nm}$ (ref. 13)). UV/vis spectroscopy can thus be applied as a useful diagnostic tool to assess the stability of **1**[•] toward air and moisture. A cuvette was charged with a dilute solution of **1**[•] in CH₂Cl₂ under inert conditions. A UV/vis spectrum was recorded, the cap was opened to the ambient atmosphere and closed again to avoid evaporation of the solvent. Measurements were repeated in regular intervals of 30 min and showed a linear decrease in absorbance. After 4 h, the sample still had an intense blue color; after 14 h, it was colorless.

Synthesis of the mixed Cl/SiR₃-substituted propenes **2**, **2**^{OMe}, and **2**^{Me} (R = Cl, OMe, Me)

We next converted [nBu₄N][**1**] to the neutral propene through protonation with HOSO₂CF₃ (HOTf) in CD₂Cl₂ (Scheme 4). In the ¹H NMR spectrum, the product mixture gave rise to two singlets at 3.75 and 4.09 ppm with relative intensities of 2 : 1 (the ¹H resonances of the CH units in doubly protonated [C]²⁻ appear at 3.49 ppm (ref. 15)). The ¹³C{¹H} and ²⁹Si NMR spectra were also characterized by a major and minor set of signals, both compatible with the molecular structure of the target compound **2**. An explanation of the observed NMR features lies in the formation of rotamers, **2A** and **2B**, due to restricted rotation about the sterically encumbered C–C single bond (cf. the comparable situation in (Cl₃Si)₂(H)C–C(H)(SiCl₃)₂).^{13,40} This interpretation gained support from GC-MS measurements, which gave the same molecular masses for **2A/2B** and were in line with a chemical formula of Cl₂C=C(SiCl₃)–C(H)(SiCl₃)₂ ($m/z = 511.60$, [M]⁺). Quantum-chemical calculations (ω B97X-D3(BJ)/ma-def2-QZVPP+COSMO-RS//ma-def2-TZVP(CPCM(CH₂Cl₂))) indeed predict a high barrier of rotation about the C(1)–C(2) bond of **2** ($\Delta G^\ddagger = 33.5 \text{ kcal mol}^{-1}$; the corresponding computed rotational barrier of [**1**]⁻ is $\Delta G^\ddagger = 30.1 \text{ kcal mol}^{-1}$ and the rotation activation enthalpy of the parent allyl anion was calculated to $\Delta H^\ddagger = 19 \text{ kcal mol}^{-1}$ according to ref. 41). Since a mere rotamer mixture should yield solely [**1**]⁻ as the deprotonation product, we treated **2A/2B** with various strong bases. A selective transformation was achieved by using 1 equiv. of [B]²⁻ as the proton-abstracting reagent, which indeed regenerated [**1**]⁻ quantitatively (see the ESI[†] for more details).⁴² In contrast to the reaction with HOTf, the reaction of [**1**]⁻ with 2 equiv. ethereal HCl in CD₂Cl₂ gives a product that shows only one set of signals in the NMR spectra (use of 1 equiv. ethereal HCl generates a mixture of the same product and [**1**]⁻). These signals can be assigned to compound **3**, which carries only two



Scheme 4 Conversions of [nBu₄N][**1**] to the propenes **2A/2B**, **2**^{OMeA}/**2**^{OMeB}, or **3** by treatment with HOSO₂CF₃ (HOTf), MeOH, or ethereal HCl, respectively; the reactions of [nBu₄N][**1**] or **2A/2B** with MeMgBr provide the respective products **H** or **2**^{MeA}/**2**^{MeB} (deviating from the balanced reaction equations, HOTf and MeMgBr were used in excess amounts). (i) CH₂Cl₂, room temperature; (ii) THF, 60 °C in a sealed NMR tube, 21 h; (iii) THF, reflux temperature, 1 d; (iv) 8 equiv. NMe₂Et, CH₂Cl₂, room temperature; (v) 9 equiv. NMe₂Et, CH₂Cl₂, 0 °C to room temperature; (vi) 1 equiv. [nBu₄N]Cl, CD₂Cl₂, 60 °C, 3 d.

SiCl₃ groups and is formed through C-protonation accompanied by protodesilylation (Scheme 4). The latter reduces the steric overload and, as a consequence, the rotation about the C–C single bond is no longer restricted. As previously observed in related cases, the choice of the acid obviously has a major influence on the reaction outcome (non-nucleophilic counteranion OTf⁻ vs. nucleophilic counteranion Cl⁻).^{13,15}

A controlled methanolysis of **2A/2B** again provided two isomers, **2**^{OMeA}/**2**^{OMeB} (1 : 1), and added useful NMR handles (Scheme 4):⁴³ (i) the OMe and CH integrals confirmed the presence of one unique Si(OMe)₃ group, two chemically equivalent Si(OMe)₃ groups, and one CH proton in **2**^{OMeA}/**2**^{OMeB}. (ii) Selective NOESY NMR experiments enabled an assignment of the individual signal sets to rotamer **2**^{OMeA} or **2**^{OMeB}. With a similar motivation as in the case of the methanolysis reaction, **2A/2B** were also treated with excess MeMgBr in THF. After workup, we isolated **2**^{MeA}/**2**^{MeB} in a ratio of 2 : 1 (Scheme 4; computed rotational barrier about the C–C single bond: $\Delta G^\ddagger = 34.0 \text{ kcal mol}^{-1}$). The fact that **2**^{MeA} is the dominant rotamer was confirmed by a NOESY-NMR experiment.

Conversion of $[1]^-$ and 2^{Me} to the silylated cyclopropene **H** and the silylated allenes **Li[4]**–**6**

According to *in situ* NMR spectroscopy, the Grignard reagent does not deprotonate the propene cores of 2^{Me} A/ 2^{Me} B: a putative tris(trimethylsilyl) derivative $[1^{\text{Me}}]^-$ should have a less stabilized carbanionic center than $[1]^-$, because the α effect of a SiMe_3 fragment is smaller than that of an SiCl_3 unit, which decreases the acidity of 2^{Me} relative to **2**.^{4,13} The anticipated higher reactivity of $[1^{\text{Me}}]^-$ makes this anion another worthwhile synthesis target. In a first attempt, **2A/2B** were replaced by $[n\text{Bu}_4\text{N}][1]$ in the Grignard reaction, which, however, did not furnish $[1^{\text{Me}}]^-$ but rather the cyclopropene **H**⁴⁴ (Scheme 4): As expected, all three SiCl_3 groups were converted to SiMe_3 groups. Against *a priori* expectations, the nucleophilicity of the carbanion was increased to the point that it underwent an intramolecular Cl^- substitution to close the three-membered ring. Moreover, migration of one silyl group occurred⁴⁵ and the second C-bonded Cl atom was replaced by a Me substituent. Silylated cyclopropenes are valuable building blocks for organic synthesis.⁴⁶ Derivative **H** was previously obtained *via* five steps in $\sim 10\%$ yield.^{44,47} In comparison, our two-step synthesis (80% yield) represents a significant improvement. Coming back to $[1^{\text{Me}}]^-$, we next employed the extremely basic *t*BuLi to accomplish the deprotonation of 2^{Me} . The most selective reaction was reached with 2 equiv. of *t*BuLi, which gave the lithiated allene **Li[4]**⁴⁸ (quantitative conversion; Scheme 5).⁴⁹ In terms of the reaction mechanism, we propose that an initial proton

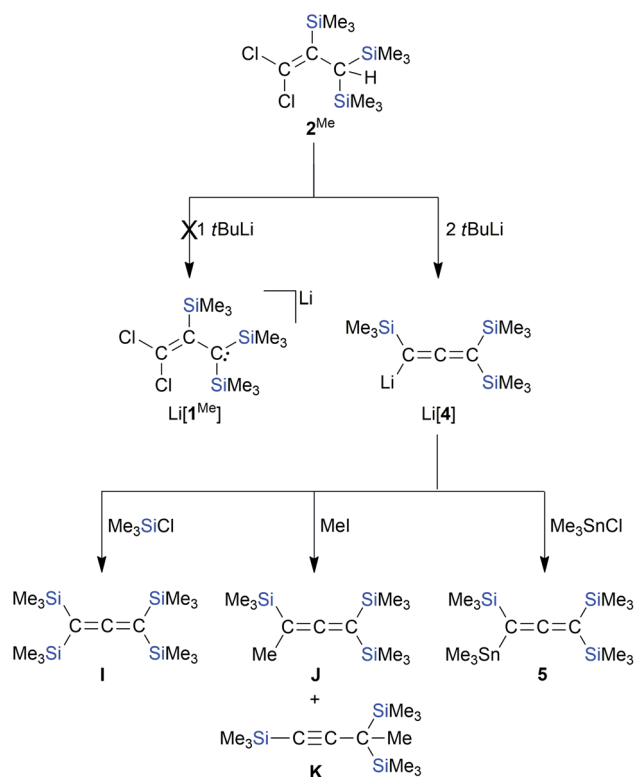

Scheme 5 The reaction of 2^{Me} with *t*BuLi does not lead to $\text{Li}[1^{\text{Me}}]$ but to **Li[4]**. **Li[4]** reacts with Me_3SiCl , MeI , or Me_3SnCl to form the derivatives **I**, **J**/**K**, or **5**, respectively (THF, room temperature).

abstraction generates $[1^{\text{Me}}]^-$, which, similar to the case of the reaction $[n\text{Bu}_4\text{N}][1] + \text{MeMgBr} \rightarrow \text{H}$ (Scheme 4), cyclizes to an **H**-type cyclopropene carrying a CCl instead of the CMe fragment. With the bulky *t*BuLi, the chlorocyclopropene does not undergo $\text{Cl}/t\text{Bu}$ but rather Cl/Li exchange. Ample precedence exists for the rearrangement of (lithiated) cyclopropenes to (lithiated) allenes.^{28,50} **Li[4]** straightforwardly reacts with Me_3SiCl , MeI , or Me_3SnCl to furnish the derivatives **I**,⁴⁸ **J**/**K**,⁴⁸ and **5**, respectively (Scheme 5). Also allenes, especially the silylated ones, are attracting great attention as building blocks in organic synthesis and in the field of materials science.⁵¹ The time- and cost-efficient new protocol reported here is therefore a potentially valuable addition to the existing toolbox of allene syntheses.⁵² Along these lines, it would be desirable to include $[1]^-$ as starting material for the synthesis of perchlorinated **Li[4]**-type compounds.⁵⁰ Given that $[n\text{Bu}_4\text{N}][1]$ *per se* has no tendency to eliminate Cl^- ions even at elevated temperatures, we added AlCl_3 in CH_2Cl_2 to support Cl^- abstraction (*cf.* Scheme 1).¹⁵ After stirring at room temperature overnight, the reaction mixture had adopted a deep green color. The $[n\text{Bu}_4\text{N}][\text{AlCl}_4]$ formed was precipitated by addition of *n*-hexane, all volatiles were removed from the filtrate under reduced pressure, and the green oily residue was subjected to distillation. Only one fraction was obtained (10^{-3} mbar, 70°C), which possessed a bright blue color; some yellow-brown material remained in the distillation sump. The blue distillate collected showed no signal in the ^1H NMR spectrum, three ^{13}C resonances and two ^{29}Si NMR signals. One of the C nuclei was strongly deshielded ($\delta(^{13}\text{C}) = 216.7$, CD_2Cl_2), as is characteristic for central allene-C atoms. A typical allene stretching band was observed at 1928.5 cm^{-1} in the IR spectrum. A GC-MS measurement confirmed the formation of the trifold SiCl_3 -substituted chloroallene **6** ($m/z = 473.60$, $[\text{M}]^+$; Scheme 6). The apparent blue color of **6** would be unique among comparable allene species (*cf.* the colorless compounds **I**, **J**, and **5**) and, on the other hand, is reminiscent of the radical **1'**. Indeed, an EPR spectrum of the blue fraction in CH_2Cl_2 affirmed the presence of this NMR-silent radical in addition to **6**. In order to gently quench **1'**, the solution was treated with 1,4-cyclohexadiene, whereupon the blue color disappeared over the course of 2 h. NMR spectroscopy on the colorless solution still showed the resonances of **6**, but also the signals of **2** and C_6H_6 (Scheme 6). After removal of all volatile components, the mixture of **6** and **2** was dissolved in Et_2O and treated with excess MeMgBr to produce the corresponding derivatives $(\text{Me}_3\text{Si})(\text{Cl})\text{C}=\text{C}=\text{C}(\text{SiMe}_3)_2$ and 2^{Me} , respectively. From the proton integral values in the ^1H NMR spectrum of this

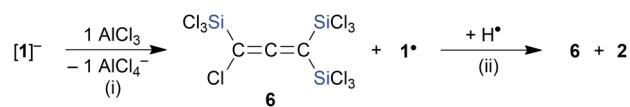

Scheme 6 Synthesis of **6** in a mixture with side product **1'** through reaction of $[1]^-$ with AlCl_3 ; the identity of **1'** was confirmed by an H-atom abstraction reaction, which gave **2** and C_6H_6 . (i) CH_2Cl_2 , room temperature; (ii) excess 1,4-cyclohexadiene, CD_2Cl_2 , room temperature; C_6H_6 was observed as byproduct.

blend, it was then estimated that the fraction of 2^{Me} was about 20% – which, in turn, should also be true for the fraction of 1^{\cdot} in the blue mixture with **6**. We finally succeeded in the isolation of **6** (24% yield) by performing the 1,4-cyclohexadiene quench on a preparative scale: while $6/1^{\cdot}$ cannot be separated by fractional distillation, this is conveniently possible for $6/2$. How was 1^{\cdot} formed? Bock *et al.* have already advertised the system $\text{AlCl}_3/\text{CH}_2\text{Cl}_2$ as a strong oxidizing agent and proposed the chloromethyl cation $[\text{CH}_2\text{Cl}][\text{AlCl}_4]$ as the actual electron acceptor.⁵³ So far, we never observed such reactivity (*e.g.*, in the synthesis of **E**; Scheme 1),^{14,15} but in the present case, it may well play a role.

Conclusions

We found that hexachloropropene ($\text{Cl}_2\text{C}=\text{C}(\text{Cl})-\text{CCl}_3$) reacts with the $\text{Si}_2\text{Cl}_6/\text{Cl}^-$ system (1 : 4 : 1) to give the trisilylated allyl anion $[\text{Cl}_2\text{C}=\text{C}(\text{SiCl}_3)-\text{C}(\text{SiCl}_3)_2]^-$ ($[1]^-$). The remarkable coexistence of a C-centered nucleophile with three electrophilic Si atoms in the same molecule is a consequence of the pronounced α effect of the SiCl_3 groups, which electronically stabilize the electron lone pair. The Cl-to- SiCl_3 exchange underlying the formation of $[1]^-$ involves $[\text{SiCl}_3]^-$ ions as key intermediates and stops at the stage of the triply silylated product presumably due to steric constraints. As a result, $[1]^-$ presents four types of synthetically useful functional groups (*i.e.*, Cl, SiCl_3 , $\text{C}=\text{C}$, $[\text{R}_3\text{C}]^-$) that can be employed in further derivatizations. Indeed, starting from readily available $[1]^-$, a variety of still highly functionalized C_3 compounds are accessible, such as the thermostable blue radical 1^{\cdot} , the propenes $\text{Cl}_2\text{C}=\text{C}(\text{SiR}'_3)-\text{C}(\text{SiR}'_3)_2\text{H}$ ($\text{R}' = \text{Cl, Me, OMe}$; **2**, 2^{Me} , 2^{OMe}), or the allene $\text{Cl}_3\text{Si}(\text{Cl})\text{C}=\text{C}=\text{C}(\text{SiCl}_3)_2$ (**6**). The silylation protocol and follow-up reactions presented here thus represent a time- and cost-efficient addition to the currently available toolbox for the preparation of organosilicon building blocks.

Data availability

Experimental and computational data associated with this article have been provided in the ESI.†

Author contributions

I. G. synthesized and characterized the compounds. M. Bu. performed the quantum-chemical calculations. B. E. performed the EPR measurement and related simulation. M. Bo. performed the X-ray crystal structure analysis. H.-W. L., S. G. and M. W. supervised the project. The manuscript was written by M. W. and I. G. and edited by all the co-authors.

Conflicts of interest

There are no conflicts to declare.

Acknowledgements

The authors are grateful to the Evonik Operations GmbH, Rheinfelden (Germany), for the generous donation of Si_2Cl_6 . I. G. wishes to thank the Evonik Foundation for a PhD grant. This work was partially funded by the Bundesministerium für Wirtschaft und Energie through the WIPANO grant number 03THW10K19. The German Research Foundation (DFG) is gratefully acknowledged for financial support through a Gottfried Wilhelm Leibniz prize to S. G.

Notes and references

- 1 T. Hiyama and M. Oestreich, *Organosilicon Chemistry*, Wiley-VCH, Weinheim, Germany, 2019.
- 2 (a) D. Yan, J. Mohsseni-Ala, N. Auner, M. Bolte and J. W. Bats, *Chem.–Eur. J.*, 2007, **13**, 7204–7214; (b) D. Yan, M. Bolte and N. Auner, *J. Organomet. Chem.*, 2008, **693**, 908–916; (c) J. Mei, N. L. C. Leung, R. T. K. Kwok, J. W. Y. Lam and B. Z. Tang, *Chem. Rev.*, 2015, **115**, 11718–11940.
- 3 (a) R. H. Baney, M. Itoh, A. Sakakibara and T. Suzuki, *Chem. Rev.*, 1995, **95**, 1409–1430; (b) D. A. Loy and K. J. Shea, *Chem. Rev.*, 1995, **95**, 1431–1442; (c) R. Murugavel, A. Voigt, M. G. Walawalkar and H. W. Roesky, *Chem. Rev.*, 1996, **96**, 2205–2236; (d) H. C. L. Abbenhuis, *Chem.–Eur. J.*, 2000, **6**, 25–32; (e) K. J. Shea and D. A. Loy, *Chem. Mater.*, 2001, **13**, 3306–3319; (f) D. B. Cordes, P. D. Lickiss and F. Rataboul, *Chem. Rev.*, 2010, **110**, 2081–2173; (g) F. Wang, X. Lu and C. He, *J. Mater. Chem.*, 2011, **21**, 2775–2782; (h) T. Baumgartner and F. Jäkle, *Main Group Strategies towards Functional Hybrid Materials*, John Wiley & Sons, Ltd., Chichester, 1st edn, 2018; (i) F. Dong, L. Lu and C.-S. Ha, *Macromol. Chem. Phys.*, 2019, **220**, 1800324; (j) F. Seidi, M. Jouyandeh, A. Taghizadeh, M. Taghizadeh, S. Habibzadeh, Y. Jin, H. Xiao, P. Zarrintaj and M. R. Saeb, *Surf. Innovations*, 2021, **9**, 3–16.
- 4 M. A. Brook, *Silicon in Organic, Organometallic, and Polymer Chemistry*, John Wiley & Sons, New York, 2000, vol. 1.
- 5 (a) U. Eduok, O. Faye and J. Szpunar, *Prog. Org. Coat.*, 2017, **111**, 124–163; (b) F. Liravi and E. Toyserkani, *Addit. Manuf.*, 2018, **24**, 232–242; (c) P. Mazurek, S. Vudayagiri and A. L. Skov, *Chem. Soc. Rev.*, 2019, **48**, 1448–1464; (d) T. J. Wallin, L.-E. Simonsen, W. Pan, K. Wang, E. Giannelis, R. F. Shepherd and Y. Mengüç, *Nat. Commun.*, 2020, **11**, 4000.
- 6 (a) D. J. Peterson, *J. Org. Chem.*, 1968, **33**, 780–784; (b) L. F. van Staden, D. Gravestock and D. J. Ager, *Chem. Soc. Rev.*, 2002, **31**, 195–200.
- 7 (a) Y. Hatanaka and T. Hiyama, *Synlett*, 1991, **1991**, 845–853; (b) S. E. Denmark and R. F. Sweis, *Chem. Pharm. Bull.*, 2002, **50**, 1531–1541; (c) T. Hiyama, *J. Organomet. Chem.*, 2002, **653**, 58–61; (d) T. Hiyama and E. Shirakawa, *Top. Curr. Chem.*, 2002, **219**, 61–85; (e) S. E. Denmark and M. H. Ober, *Aldrichimica Acta*, 2003, **36**, 75–85.
- 8 (a) K. Tamao, N. Ishida, T. Tanaka and M. Kumada, *Organometallics*, 1983, **2**, 1694–1696; (b) K. Tamao, T. Kakui, M. Akita, T. Iwahara, R. Kanatani, J. Yoshida and

- M. Kumada, *Tetrahedron*, 1983, **39**, 983–990; (c) K. Tamao and N. Ishida, *J. Organomet. Chem.*, 1984, **269**, C37–C39; (d) K. Tamao, M. Kumada and K. Maeda, *Tetrahedron Lett.*, 1984, **25**, 321–324.
- 9 (a) A. Hosomi and H. Sakurai, *Tetrahedron Lett.*, 1976, **17**, 1295–1298; (b) A. Hosomi and K. Miura, *Bull. Chem. Soc. Jpn.*, 2004, **77**, 835–851; (c) J. H. Lee, *Tetrahedron*, 2020, **76**, 131351.
- 10 N. Selander, J. R. Paasch and K. J. Szabó, *J. Am. Chem. Soc.*, 2011, **133**, 409–411.
- 11 (a) H. Watanabe, M. Saito, N. Sutou and Y. Nagai, *J. Chem. Soc., Chem. Commun.*, 1981, 617–618; (b) T. K. Sarkar, *Synthesis*, 1990, **1990**, 969–983; (c) T. K. Sarkar, *Synthesis*, 1990, **1990**, 1101–1111; (d) W. E. Crowe, D. R. Goldberg and Z. J. Zhang, *Tetrahedron Lett.*, 1996, **37**, 2117–2120; (e) L. Chabaud, P. James and Y. Landais, *Eur. J. Org. Chem.*, 2004, 3173–3199; (f) A. Barbero and F. J. Pulido, *Acc. Chem. Res.*, 2004, **37**, 817–825; (g) M. Oestreich and G. Auer, *Adv. Synth. Catal.*, 2005, **347**, 637–640; (h) D. J. Vyas and M. Oestreich, *Chem. Commun.*, 2010, **46**, 568–570; (i) D. J. Vyas and M. Oestreich, *Angew. Chem., Int. Ed.*, 2010, **49**, 8513–8515; (j) L. B. Delvos, D. J. Vyas and M. Oestreich, *Angew. Chem., Int. Ed.*, 2013, **52**, 4650–4653; (k) W. Xue and M. Oestreich, *Synthesis*, 2019, **51**, 233–239; (l) W.-L. Yu, Y.-C. Luo, L. Yan, D. Liu, Z.-Y. Wang and P.-F. Xu, *Angew. Chem., Int. Ed.*, 2019, **58**, 10941–10945; (m) J.-H. Zeng, J.-J. Chen, L. Chen and Z.-P. Zhan, *Org. Chem. Front.*, 2020, **7**, 1132–1136.
- 12 (a) L. Gao, X. Lin, J. Lei, Z. Song and Z. Lin, *Org. Lett.*, 2012, **14**, 158–161; (b) L. Gao, Y. Zhang and Z. Song, *Synlett*, 2013, **24**, 139–144; (c) S. Xu, R. Chen, Z. Fu, Y. Gao and J. Wang, *J. Org. Chem.*, 2018, **83**, 6186–6192.
- 13 I. Georg, J. Teichmann, M. Bursch, J. Tillmann, B. Endeward, M. Bolte, H.-W. Lerner, S. Grimme and M. Wagner, *J. Am. Chem. Soc.*, 2018, **140**, 9696–9708.
- 14 J. Teichmann, C. Kunkel, I. Georg, M. Moxter, T. Santowski, M. Bolte, H.-W. Lerner, S. Bade and M. Wagner, *Chem.–Eur. J.*, 2019, **25**, 2740–2744.
- 15 I. Georg, M. Bursch, J. B. Stückrath, E. Alig, M. Bolte, H.-W. Lerner, S. Grimme and M. Wagner, *Angew. Chem., Int. Ed.*, 2020, **59**, 16181–16187.
- 16 J. Tillmann, J. H. Wender, U. Bahr, M. Bolte, H.-W. Lerner, M. C. Holthausen and M. Wagner, *Angew. Chem., Int. Ed.*, 2015, **54**, 5429–5433.
- 17 J. Teichmann, M. Bursch, B. Köstler, M. Bolte, H.-W. Lerner, S. Grimme and M. Wagner, *Inorg. Chem.*, 2017, **56**, 8683–8688.
- 18 For a review article on the chemistry developed so far with the $\text{Si}_2\text{Cl}_6/\text{Cl}^-$ system, see: J. Teichmann and M. Wagner, *Chem. Commun.*, 2018, **54**, 1397–1412.
- 19 J. Tillmann, M. Moxter, M. Bolte, H.-W. Lerner and M. Wagner, *Inorg. Chem.*, 2015, **54**, 9611–9618.
- 20 U. Böhme, M. Gerwig, F. Gründler, E. Brendler and E. Kroke, *Eur. J. Inorg. Chem.*, 2016, **2016**, 5028–5035.
- 21 M. Olaru, M. F. Hesse, E. Rychagova, S. Ketkov, S. Mebs and J. Beckmann, *Angew. Chem., Int. Ed.*, 2017, **56**, 16490–16494.
- 22 M. B. Geeson and C. C. Cummins, *Science*, 2018, **359**, 1383–1385.
- 23 M. B. Geeson, P. Ríos, W. J. Transue and C. C. Cummins, *J. Am. Chem. Soc.*, 2019, **141**, 6375–6384.
- 24 J. Tillmann, L. Meyer, J. I. Schweizer, M. Bolte, H.-W. Lerner, M. Wagner and M. C. Holthausen, *Chem.–Eur. J.*, 2014, **20**, 9234–9239.
- 25 M. A. Fox and J. K. Whitesell, *Organic Chemistry*, Jones and Bartlett Publishers, Sudbury, Mass., 3rd edn, 2004.
- 26 (a) J. Da Chai and M. Head-Gordon, *Phys. Chem. Chem. Phys.*, 2008, **10**, 6615–6620; (b) Y.-S. Lin, G.-D. Li, S.-P. Mao and J.-D. Chai, *J. Chem. Theory Comput.*, 2013, **9**, 263–272; (c) J. Zheng, X. Xu and D. G. Truhlar, *Theor. Chem. Acc.*, 2011, **128**, 295–305; (d) S. Grimme, J. Antony, S. Ehrlich and H. Krieg, *J. Chem. Phys.*, 2010, **132**, 154104; (e) S. Grimme, A. Hansen, J. G. Brandenburg and C. Bannwarth, *Chem. Rev.*, 2016, **116**, 5105–5154; (f) V. Barone and M. Cossi, *J. Phys. Chem. A*, 1998, **102**, 1995–2001; (g) ORCA: An ab initio, density functional and semiempirical program package, V. 4.2.1, MPI für Kohlenforschung: Mülheim a. d. Ruhr, Germany, 2019.
- 27 E. D. Glendening, C. R. Landis and F. Weinhold, *J. Comput. Chem.*, 2013, **34**, 1429–1437.
- 28 W. E. Billups and R. E. Bachman, *Tetrahedron Lett.*, 1992, **33**, 1825–1826.
- 29 C. Korhummel and M. Hanack, *Chem. Ber.*, 1989, **122**, 2187–2192.
- 30 A related reaction, in which $[\text{CCl}_3]^-$ replaces $[\text{SiCl}_3]^-$ as chloronium-abstracting reagent in the conversion of C_3Cl_6 to **F** has been published: F. Boberg and H. Khalaf, *Justus Liebig's Ann. Chem.*, 1970, **741**, 153–156. The facile dimerization of **F** to **G** in the absence of other reaction partners is also well documented: (a) A. Roedig, G. Märkl and B. Heinrich, *Angew. Chem., Int. Ed. Engl.*, 1963, **2**, 47; (b) A. Roedig and B. Heinrich, *Chem. Ber.*, 1967, **100**, 3716–3724.
- 31 The calculated activation barrier of the reaction $2\text{F} \rightarrow \text{G}$ ($\Delta G = 30.2 \text{ kcal mol}^{-1}$; cf. Scheme 3) is considerably higher than the experimentally determined barrier ($\Delta H^\ddagger = 10.6 \pm 3.1 \text{ kcal mol}^{-1}$): N. Detzer and A. Roedig, *Tetrahedron*, 1971, **27**, 5697–5703.
- 32 A. Klamt, *J. Phys. Chem.*, 1995, **99**, 2224–2235.
- 33 F. Eckert and A. Klamt, *AIChE J.*, 2002, **48**, 369–385.
- 34 The reaction of perchlorocyclopropene, *cyclo-C}_3\text{Cl}_4*, with $\text{Si}_2\text{Cl}_6/\text{Cl}^-$ (1 : 4 : 1) in CD_2Cl_2 is unselective and leads to a complex mixture of products, which contain not even traces of $[\mathbf{1}]^-$ ($^{13}\text{C}\{^1\text{H}\}$ NMR-spectroscopic control). Therefore, *cyclo-C}_3\text{Cl}_4* can be excluded as an intermediate in the reaction $\text{C}_3\text{Cl}_6 \rightarrow [\mathbf{1}]^-$.
- 35 A related example is the blue radical $[\mathbf{B}]^-$, which is accessible via comproportionation of $[\mathbf{B}]^{2-}$ and \mathbf{B}^{13} . Attempts at the targeted synthesis of $\mathbf{1}^*$ by H-atom abstraction with azobis(isobutyronitrile) (AIBN) failed.
- 36 For selected other remarkably inert organic radicals, see: (a) U. Groß, S. Rüdiger and A. Dimitrov, *J. Fluorine Chem.*, 1996, **76**, 139–144; (b) K. Goto, T. Kubo, K. Yamamoto, K. Nakasuji, K. Sato, D. Shiomi, T. Takui, M. Kubota, T. Kobayashi,

- K. Yakusi and J. Ouyang, *J. Am. Chem. Soc.*, 1999, **121**, 1619–1620; (c) R. G. Hicks, *Org. Biomol. Chem.*, 2007, **5**, 1321–1338; (d) A. Ueda, H. Wasa, S. Nishida, Y. Kanzaki, K. Sato, D. Shiomi, T. Takui and Y. Morita, *Chem.–Eur. J.*, 2012, **18**, 16272–16276; (e) J. P. Peterson, M. R. Geraskina, R. Zhang and A. H. Winter, *J. Org. Chem.*, 2017, **82**, 6497–6501; (f) K. Kato, K. Furukawa, T. Mori and A. Osuka, *Chem.–Eur. J.*, 2018, **24**, 572–575; (g) K. Kato and A. Osuka, *Angew. Chem., Int. Ed.*, 2019, **58**, 8978–8986; (h) B. Tang, J. Zhao, J.-F. Xu and X. Zhang, *Chem. Sci.*, 2020, **11**, 1192–1204; (i) M. Harada, M. Tanioka, A. Muranaka, T. Aoyama, S. Kamino and M. Uchiyama, *Chem. Commun.*, 2020, **56**, 9565–9568.
- 37 S. Hirata and M. Head-Gordon, *Chem. Phys. Lett.*, 1999, **314**, 291.
- 38 (a) T. Stein, L. Kronik and R. Baer, *J. Chem. Phys.*, 2009, **131**, 244119; (b) M. Rubešová, E. Muchová and P. Slavíček, *J. Chem. Theory Comput.*, 2017, **13**, 4972–4983.
- 39 S. Stoll and A. Schweiger, *J. Magn. Reson.*, 2006, **178**, 42–55.
- 40 G. Fritz, S. Lauble, R. Befurt, K. Peters, E.-M. Peters and F. H. G. von Schnering, *Z. Anorg. Allg. Chem.*, 1993, **619**, 1494–1511.
- 41 R. González-Luque, I. Nebot-Gil, M. Merchán and F. Tomás, *Theor. Chim. Acta*, 1986, **69**, 101–106.
- 42 The use of 0.5 equiv. of $[n\text{Bu}_4\text{N}]_2[\text{B}]$ yielded a 1 : 1 : 1 mixture of **2**, $[n\text{Bu}_4\text{N}][\mathbf{1}]$, and $[n\text{Bu}_4\text{N}][(\text{Cl}_3\text{Si})_2(\text{H})\text{C}-\text{C}(\text{SiCl}_3)_2][n\text{Bu}_4\text{N}][\text{BH}]$. Because of the two immediately adjacent negative charges, $[\text{B}]^{2-}$ is apparently a stronger base than $[\mathbf{1}]^-$ (proton transfer from **2** is nevertheless slow); the Brønsted basicity of $[\text{BH}]^-$ is no longer high enough to deprotonate **2**.
- 43 A comparably selective methanolysis reaction leads from $[n\text{Bu}_4\text{N}][\mathbf{1}]$ to $2^{\text{OMe}}\text{A}/2^{\text{OMe}}\text{B}$ and is the basis for the titration experiment discussed.
- 44 G. Maier, J. Neudert, O. Wolf, D. Pappusch, A. Sekiguchi, M. Tanaka and T. Matsuo, *J. Am. Chem. Soc.*, 2002, **124**, 13819–13826.
- 45 (a) A. J. Ashe, *J. Am. Chem. Soc.*, 1970, **92**, 1233–1235; (b) C. W. Spangler, *Chem. Rev.*, 1976, **76**, 187–217; (c) M. Kira and T. Iwamoto, in *The Chemistry of Organic Silicon Compounds*, ed. Z. Rappoport and Y. Apeloig, John Wiley & Sons, Ltd., Chichester, 2003, vol. 3, pp. 853–948.
- 46 (a) H. A. Buchholz, G. K. S. Prakash, D. Deffieux and G. A. Olah, *Proc. Natl. Acad. Sci. U. S. A.*, 1999, **96**, 10003–10005; (b) S. Chuprakov, D. A. Malyshev, A. Trofimov and V. Gevorgyan, *J. Am. Chem. Soc.*, 2007, **129**, 14868–14869; (c) E. A. F. Fordyce, Y. Wang, T. Luebbbers and H. W. Lam, *Chem. Commun.*, 2008, 1124–1126; (d) T. J. Thomas, B. A. Merritt, B. E. Lemma, A. M. McKoy, T. Nguyen, A. K. Swenson, J. L. Mills and M. G. Coleman, *Org. Biomol. Chem.*, 2016, **14**, 1742–1747; (e) R. Vicente, *Synthesis*, 2016, **48**, 2343–2360.
- 47 G. Maier, D. Volz and J. Neudert, *Synthesis*, 1992, **1992**, 561–564.
- 48 R. West and P. C. Jones, *J. Am. Chem. Soc.*, 1969, **91**, 6156–6161.
- 49 The use of 1 equiv. of *t*BuLi afforded the fourfold SiMe₃-substituted allene **I**, leaving some of the starting material 2^{Me} unconsumed. We assume that Li[**4**] is formed as an intermediate that takes up one SiMe₃ group from residual 2^{Me} to give **I**.
- 50 (a) R. Kostikov and A. de Meijere, *J. Chem. Soc., Chem. Commun.*, 1984, 1528–1529; (b) P. Binger, P. Müller, R. Wenz and R. Mynott, *Angew. Chem., Int. Ed. Engl.*, 1990, **29**, 1037–1038; (c) R. Walsh, S. Untiedt and A. de Meijere, *Chem. Ber.*, 1994, **127**, 237–245; (d) A. de Meijere, D. Faber, U. Heinecke, R. Walsh, T. Müller and Y. Apeloig, *Eur. J. Org. Chem.*, 2001, **6**, 663–680; (e) I. Zrinski, N. Novak-Coumbassa and M. Eckert-Maksic, *Organometallics*, 2004, **23**, 2806–2809; (f) J. Li, C. Sun, S. Demerzhan and D. Lee, *J. Am. Chem. Soc.*, 2011, **133**, 12964–12967; (g) Y. Liu, D. Zhang and S. Bi, *Organometallics*, 2012, **31**, 4769–4778; (h) A. C. Voukides, K. J. Cahill and R. P. Johnson, *J. Org. Chem.*, 2013, **78**, 11815–11823.
- 51 (a) R. Zimmer, C. U. Dinesh, E. Nandan and F. A. Khan, *Chem. Rev.*, 2000, **100**, 3067–3125; (b) M. A. Shengming, *Acc. Chem. Res.*, 2009, **42**, 1679–1688; (c) B. Alcaide, P. Almendros and C. Aragoncillo, *Chem. Soc. Rev.*, 2010, **39**, 783–816; (d) T. M. Gregg, R. F. Algera, J. R. Frost, F. Hassan and R. J. Stewart, *Tetrahedron Lett.*, 2010, **51**, 6429–6432; (e) F. López and J. L. Mascareñas, *Chem.–Eur. J.*, 2011, **17**, 418–428; (f) S. Yu and S. Ma, *Angew. Chem., Int. Ed.*, 2012, **51**, 3074–3112; (g) P. Rivera-Fuentes and F. Diederich, *Angew. Chem., Int. Ed.*, 2012, **51**, 2818–2828; (h) T. Lechel, F. Pfrengle, H.-U. Reissig and R. Zimmer, *ChemCatChem*, 2013, **5**, 2100–2130; (i) C. S. Adams, C. D. Weatherly, E. G. Burke and J. M. Schomaker, *Chem. Soc. Rev.*, 2014, **43**, 3136–3163; (j) M. D. Jovanovic, M. R. Petkovic and V. M. Savic, *Synthesis*, 2021, **53**, 1035–1045.
- 52 (a) J. A. Marshall and C. M. Grant, *J. Org. Chem.*, 1999, **64**, 8214–8219; (b) L. K. Sydnes, *Chem. Rev.*, 2003, **103**, 1133–1150; (c) K. M. Brummond and J. E. DeForrest, *Synthesis*, 2007, 795–818; (d) S. Yu and S. Ma, *Chem. Commun.*, 2011, **47**, 5384–5418; (e) T. Hashimoto, K. Sakata, F. Tamakuni, M. J. Dutton and K. Maruoka, *Nat. Chem.*, 2013, **5**, 240–244; (f) S. Wu, X. Huang, W. Wu, P. Li, C. Fu and S. Ma, *Nat. Commun.*, 2015, **6**, 7946; (g) W.-D. Chu, Y. Zhang and J. Wang, *Catal. Sci. Technol.*, 2017, **7**, 4570–4579.
- 53 (a) H. Bock, G. Brähler, U. Henkel, R. Schlecker and D. Seebach, *Chem. Ber.*, 1980, **113**, 289–301; (b) H. Bock, G. Brähler, D. Dauplaise and J. Meinwald, *Chem. Ber.*, 1981, **114**, 2622–2631; (c) H. Bock and W. Kaim, *Acc. Chem. Res.*, 1982, **15**, 9–17; (d) H. Bock, U. Stein and P. Rittmeyer, *Angew. Chem., Int. Ed. Engl.*, 1982, **21**, 533–534; (e) H. Bock and U. Lechner-Knoblauch, *J. Organomet. Chem.*, 1985, **294**, 295–304; (f) H. Bock, *Angew. Chem., Int. Ed. Engl.*, 1989, **28**, 1627–1650; (g) H. Bock and B. Solouki, *Chem. Rev.*, 1995, **95**, 1161–1190; (h) N. G. Connelly and W. E. Geiger, *Chem. Rev.*, 1996, **96**, 877–910.