

# Objective measurement of lung volume recruitment therapy: laboratory and clinical validation

Phoebe E Naughton,<sup>1,2</sup> Nicole Sheers,<sup>1,3</sup> David J Berlowitz ,<sup>1,2,3,4</sup> Mark E Howard,<sup>1,4</sup> Douglas A McKim,<sup>5,6,7</sup> Sherri L Katz<sup>5,8,9</sup>

**To cite:** Naughton PE, Sheers N, Berlowitz DJ, *et al.* Objective measurement of lung volume recruitment therapy: laboratory and clinical validation. *BMJ Open Respi Res* Published Online First: [please include Day Month Year]. doi:10.1136/bmjresp-2021-000918

► Additional supplemental material is published online only. To view, please visit the journal online (<http://dx.doi.org/10.1136/bmjresp-2021-000918>).

Received 10 March 2021  
Accepted 11 July 2021

## ABSTRACT

Lung volume recruitment manoeuvres are often prescribed to maintain respiratory health in neuromuscular disease. Unfortunately, no current system accurately records delivered dose. This study determined the performance characteristics of a novel, objective, manual lung volume recruitment bag counter ('the counter') with bench and healthy volunteer testing, as well as in individuals with neuromuscular disease. We undertook (1) bench test determination of activation threshold, (2) bench and healthy volunteer fidelity testing during simulated patient interface leak and different pressure compressions and (3) comparisons with self-report in individuals with neuromuscular disease. The data are reported as summary statistics, compression counts, percentage of recorded versus delivered compressions and concordance (Cohen's kappa (K) and absolute agreement).

**Results** Minimum counter activation pressure under conditions of zero leak was  $1.9 \pm 0.4$  cm H<sub>2</sub>O. No difference was observed between the number of repetitions delivered and recorded during high airway pressure condition. Interface leak approximating 25% resulted in underestimation of repetition counts, and once the leak was at 50% or beyond, the counter recorded no activity. Faster sampling frequency collected data with more fidelity. Counter data agreed with diary self-report during community trials (16 participants, 960 participant days, 77% agreement, Cohen's K=0.66 and  $p < 0.001$ ). Disagreement typically favoured more diary reported (18%) than counter (5%) sessions.

**Conclusions** The performance characteristics of a new lung volume recruitment counter have been established in both laboratory and community settings. Objective usage and dosage data should accelerate new knowledge development and better translation of lung volume recruitment therapy into policy and practice.

## INTRODUCTION

Many neuromuscular diseases (NMDs) result in progressive weakness of the respiratory muscles, which leads to decreases in lung capacity and a reduced ability to cough effectively. Respiratory failure secondary to respiratory muscle weakness, chest wall restriction, impaired cough and recurrent respiratory

## Key messages

### What is the key question?

- What are the key performance characteristics of a novel adherence meter for lung volume recruitment?

### What is the bottom line?

- The device provides a pathway for accelerated clinical uptake of lung volume recruitment by performing a series of bench tests in normal controls and during a randomised controlled trial.

### Why read on?

- This novel device provides health professionals for the first time with an effective method of measuring patient adherence and the delivered dose of lung volume therapy.

tract infections is the predominant cause of morbidity and mortality in this population.<sup>1</sup> Lung volume recruitment (LVR) is a technique frequently used by people with NMD to achieve larger lung volumes and enhance cough. Consecutive 'breaths' of inspiratory pressure are delivered to the airways via a manual self-inflating bag ('resuscitation bag'), with or without a one-way valve, attached to an oronasal mask or mouthpiece. These consecutive, assisted breaths stack to a lung inflation volume greater than that achievable with spontaneous breathing. Previous research has demonstrated that LVR increases maximum insufflation capacities (MIC) or lung insufflation capacity (LIC)<sup>1-9</sup> and peak cough flow during the LVR.<sup>4,7-17</sup> Retrospective and cohort studies in NMD suggest that LVR may slow the decline in lung function over time.<sup>2,3,18</sup>

Despite a large literature base that recommends routine LVR for people with NMD,<sup>2,3,5,6,9,19-25</sup> little is known about how people actually use LVR therapy nor what is the optimal, effective dose. Some studies have tracked self-reported adherence to prescribed LVR therapy using diaries<sup>6,20</sup> or patient recall.<sup>21</sup> However, self-reporting has



© Author(s) (or their employer(s)) 2021. Re-use permitted under CC BY-NC. No commercial re-use. See rights and permissions. Published by BMJ.

For numbered affiliations see end of article.

### Correspondence to

Dr David J Berlowitz;  
david.berlowitz@austin.org.au

been shown to overestimate adherence to airway clearance techniques<sup>26</sup> and prescribed medication<sup>27</sup> in other chronic disease populations. Prescribed LVR dosage in the literature varies from two to four times per day<sup>2, 3, 5, 6, 9, 19–22</sup> with inconsistent relationships reported between self-reported ‘dose’ and outcomes. To determine how often people use LVR and thus establish dose–response relationships, a robust, objective measure of usage is necessary.

The primary aim of this study was thus to describe the design and assess the performance characteristics of a custom-made device (‘LVR counter’) that objectively records LVR usage. To address this aim, a series of laboratory-based tests were undertaken to determine the technical capacity of the LVR counter to:

- ▶ Determine the minimum pressure threshold that triggered LVR counter activation.
- ▶ Record LVR compressions and repetitions under low and high airway pressure conditions.
- ▶ Record LVR usage when performed with an adequate seal at the patient interface, defined as  $\leq 50\%$  leak.

Performance of the LVR counter when recording from human participants examined:

- ▶ The optimal data sampling frequency using a physiological control subject (healthy volunteer).
- ▶ The performance of the LVR counter ‘in the field’ by comparing LVR counter downloads with participant self-report during a randomised controlled clinical trial of individuals with neuromuscular disease.

## METHODS

### Equipment: LVR counter

The LVR counter, engineered by the rehabilitation engineering department at the Ottawa Hospital Rehabilitation Centre (Ontario, Canada), was designed to be attached to a commercially available LVR kit (1.6L self-inflating bag, one-way valve, tubing and mouthpiece or oronasal mask, item number 1034502; Mercury Medical, Florida, USA; [figure 1](#)). The LVR counter comprised a battery-powered state data logger (Omega OM-CP-State101A data logger, OMEGA Engineering, Stamford, Connecticut, USA) wired to two pressure switches connected in series (Model 7411–711, PSF102 Series pressure switch, DesignFlex Switches, World Magnetics Company, Traverse City, Michigan, USA). One pressure switch was connected to the LVR bag while the other connected near the patient interface via 3 mm silicone tubing ([figure 1](#) and [online supplemental file 1](#)). The state data logger registered a count only when *both* pressure switches reached minimum thresholds. This design element minimised false-positive recordings, which may occur, for example, with bag compressions in the presence of excessive patient interface leak or with no person at the interface. As such, the LVR counter was designed to be analogous to ‘time at pressure’ usage recording as used in continuous positive airway pressure therapy and thus to only record compression when both the bag was

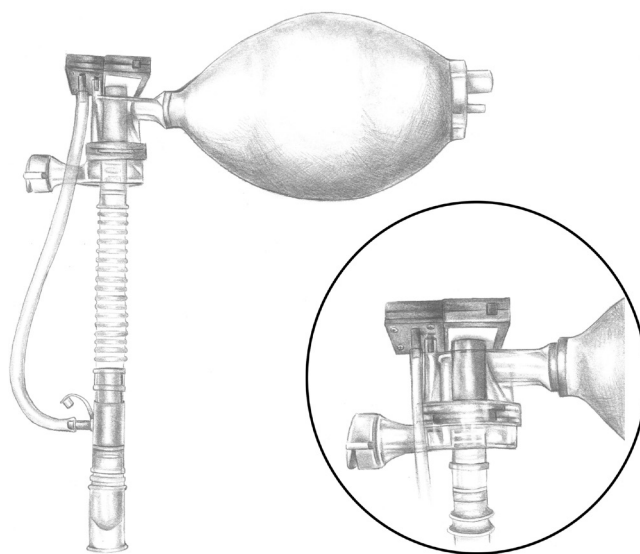

**Figure 1** Illustration of the lung volume recruitment (LVR) counter (insert), attached to a commercially available LVR kit. The LVR counter is composed of a battery-powered state data logger (Omega OM-CP-State101A data logger, OMEGA Engineering, Stamford, Connecticut, USA) wired to two pressure switches connected in series (Model 7411–711, PSF102 Series pressure switch, DesignFlex Switches, World Magnetics Company, Traverse City, Michigan, USA). The LVR kit pictured includes a 1.6L self-inflating bag, one-way valve, tubing and mouthpiece (item number 1034502; Mercury Medical, Florida, USA). Additional 3 mm silicone tubing connects one pressure switch to the LVR kit near the patient interface (via existing port on one-way valve). The second pressure switch connects directly to the LVR bag via an existing port (insert).

compressed *and* the LVR circuit interfaced with a patient. A cable (OM-CP-IFC200 USB and stereo jack connector, OMEGA Engineering) connected the state data logger to a computer running proprietary Omega software (OM-CP Data Logger Software, V.4.2.7.0, OMEGA Engineering). The software set both the data logger recording parameters (sampling rate, auto on/of and so on) and allowed for the export of counter data that had been recorded over time.

To ensure that the ‘dose’ in the following experiments was reproducible, standardised definitions were used ([table 1](#) and [figure 2](#)). In particular, the term LIC rather than MIC, as defined in a recent consensus document, was employed because the circuit includes a one-way valve, and as such, participant glottic control was not required.<sup>18, 28</sup> Much like a weight-training regime, the LVR ‘dose’ is composed of number of ‘sessions’ per day, where each ‘session’ is a number of ‘sets’ of ‘repetitions’. Each ‘repetition’ is one complete assisted inflation to LIC or MIC and is composed of consecutive ‘compressions’ of the LVR bag. The number of ‘compressions’ to achieve a ‘repetition’ depends on patient comfort, respiratory system compliance, glottic function and so on.

**Table 1** Definitions used in lung volume recruitment (LVR) therapy

Term	Definition
LVR counter	Device used to record LVR usage, incorporating pressure switches and a state data logger
Maximum insufflation capacity (MIC)	The maximum, tolerable, externally assisted inflation capacity that is dependent on the person being able to hold their breath between successive insufflations (ie, adequate glottic closure)
Lung insufflation capacity (LIC)	The maximum, tolerable, externally assisted inflation capacity that does not require the person to hold their breath
Compression (insufflation)	A single squeeze of the LVR bag. The number of compressions required to reach LIC or MIC differs for each individual
Repetition	One complete assisted inflation to LIC or MIC, typically achieved through a series of compressions (insufflations)
Set	A series of repetitions performed sequentially
Session	LVR therapy session quantified by duration (minutes) or by number of completed sets
Dose	Number of prescribed sessions tailored to the individual

### Patient and public involvement

Patients or the public were not involved in the design, conduct, reporting or dissemination plans of this research project; public and patient review of research is provided through membership of the local human research ethics committee.

### Experiment 1: minimum compression pressure required to trigger LVR counter (and generate a counted event)

The LVR circuit was connected directly to a Micro Respiratory Pressure Meter (MicroRPM, CareFusion, San Diego, California, USA) at the patient end, mimicking ideal clinical conditions (ie, bag compression and complete seal at the mouthpiece). Data sampling frequency was set at 1 hertz (Hz) for all testing. For each trial, the LVR bag was compressed slowly until the LVR counter recorded

an event. The pressure threshold required to activate the LVR counter was recorded, and 50 compressions were performed overall.

### Experiment 2: performance of the LVR counter during simulated near-complete lung inflation

Airway pressure increases substantially during LVR, and to determine if the LVR counter continued to operate under higher pressure conditions, the mouthpiece was removed and the LVR circuit attached at the patient end to a 1 L test lung (Maquet Adult 1 Litre Test Lung, item number 6006832, Getinge, New Jersey, USA). Four sets of 10 repetitions (total n=40) were administered; each repetition comprised three compressions (120 compressions in total). Between each repetition, the test circuit was disconnected to return the circuit to atmospheric

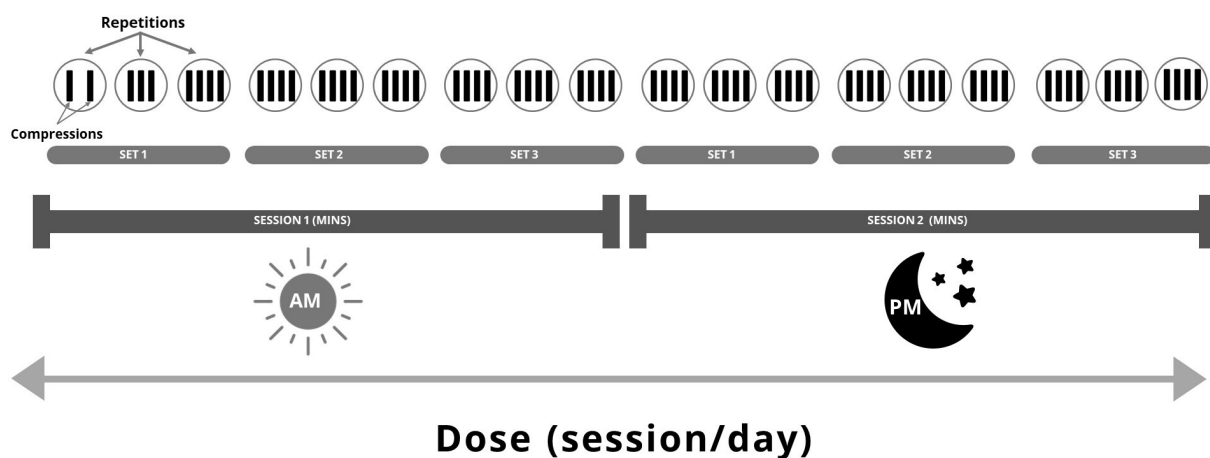

**Figure 2** Schematic representation of lung volume recruitment (LVR) dose. The LVR ‘dose’ is composed of a number of ‘sessions’ per day, with each ‘session’ consisting of ‘sets’ of ‘repetitions’. A ‘repetition’ is defined as one complete assisted inflation to maximal, tolerable, insufflation capacity. The number of consecutive ‘compressions’ or ‘insufflations’ of the LVR self-inflating bag to achieve one assisted inflation varies for each individual. This example depicts an LVR dose of three sets of three repetitions, performed twice a day. Set 1 of session 1 also illustrates the protocol for Experiment 4, whereby the number of compressions performed per repetition increased over the set (first repetition=two compressions, second repetition=three compressions and third repetition=four compressions). This was repeated for each sampling rate tested (see text for more information).

pressure. Pressures up to 100 cm H<sub>2</sub>O were delivered to mimic high-resistance (low respiratory system compliance) conditions.

### Experiment 3: assessment of the effect of simulated mouth leak on counter performance

To test whether the LVR counter only recorded a compression when there was an adequate seal at the mouthpiece, 100 compressions were performed in each of the following simulated leak conditions, achieved by covering the mouthpiece outlet to varying degrees:

- I. Zero leak: complete mouthpiece occlusion.
- II. Minimal (~25%) leak: three-quarters of the mouthpiece covered.
- III. Moderate (~50%) leak: half of the mouthpiece covered.
- IV. Large (~75%) leak: one-quarter of the mouthpiece covered.

### Experiment 4: LVR counter accuracy at different sampling frequencies and with different bag compression speeds

The accuracy of the LVR counter to record compressions and of the software to thus determine repetitions of LVR therapy on a healthy volunteer was determined at three data logger sampling rates (4, 2 and 1 Hz). At each sampling frequency, three sets of LVR with three repetitions but variable number of compressions were performed: two, three and four compressions per repetition (figure 2). The speed of compression increased across the sets.

An unblinded research assistant programmed the sampling rate into the LVR counter. The order for presentation of the sampling frequencies was randomly determined ([www.randomization.com](http://www.randomization.com)). The clinician performing LVR compressions was thus blinded to the sampling frequency of each test. The number of compressions and repetitions was compared with the actual delivered (27 compressions each composed of three sets of three repetitions, figure 2).

### Experiment 5: LVR usage in a community setting

The performance of the LVR counter in a community setting was examined using data from a clinical research trial. Concordance between two methods of assessing therapy usage was assessed in participants in the intervention arm of a randomised controlled trial ('Lung Volume Recruitment in Neuromuscular Disease: Can "breath-stacking" improve lung function, respiratory symptoms and quality of life for people with neuromuscular disease?' Australian New Zealand Clinical Trials Registry ACTRN12615000565549).

Participants were prescribed a LVR therapy dose of 'at least two sessions daily'. These LVR treatments were administered by the patient, her/his family or carer as clinically appropriate. Each LVR session comprised up to five sets of five LVR repetitions separated by quiet breathing.

Study participants used both self-report diaries and the LVR counter to record the number of LVR sessions completed per day. The LVR counter was set to sample at 1 Hz, and the time and date-stamped compression data were summarised into number and duration of sessions per day using an Excel macro (table 1 and figure 2; Excel example and associated data download instruction at <https://doi.org/10.5281/zenodo.4587974>).<sup>29</sup>

The LVR counter records compressions to memory. These compressions are combined to calculate repetitions, sets, sessions and dose as illustrated in figure 2.

Daily session data were paired by date, for days 15–75 of the 90-day study period. This mid 60-day period was selected to better represent 'normal' daily use, as it was hypothesised that participants' behaviour may be influenced immediately preclinical or postclinical trial outcome assessments. The difference between the reported (diary) and recorded (LVR counter) sessions per day and per participant was calculated. Where LVR data matched the self-reported information, this was recorded as '0'. Where there was a discrepancy in the paired data, this was categorised as 'positive diary' or 'positive LVR counter'. Concordance was analysed for 16 consecutive participants. No formal sample size calculation was conducted.

### Statistical analysis

Summary statistics for activation pressures are presented as mean±SD values. The number of compressions delivered was counted manually and compared with that recorded by the LVR counter. Percent error was calculated as (LVR count/manual count \* 100) and a 95% CI obtained using the Wilson score method. Accuracy of the LVR counter to record at different sampling rates was expressed as the percentage of actual delivered. Concordance between self-report and LVR-recorded use was reported as both a weighted Cohen's kappa (K) and as absolute agreement.

## RESULTS

### Experiments 1 and 2: performance at low and high pressures

Forty-nine of the delivered 50 compressions were recorded by the LVR counter at low pressure, resulting in a 2% error rate (95% CI=0.4 to 11). The minimum pressure threshold required to activate the device under conditions of zero leak was 1.9±0.4 cm H<sub>2</sub>O. Under conditions of higher pressure, the LVR counter recorded more compressions than were delivered (mean (95% CI) error=+13% (8 to 21). Despite this overcounting of compressions, the number of repetitions was accurately recorded by the LVR counter as 40 (table 2).

### Experiment 3: performance in the presence of leak

The LVR counter overestimated the number of single compressions delivered when zero leak was simulated and underestimated in the presence of minimal leak. If significant leak was introduced (≥50%), the LVR counter failed to record compressions (table 2).

**Table 2** Manual (ie, delivered) and LVR counter recorded counts for compressions and repetitions, for each experiment

	Compressions			Repetitions		
	Manual count	LVR counter	Percent error (95% CI)	Manual count	LVR counter	Percent error (95% CI)
Experiment 1	50	49	2			
Experiment 2						
Set 1	30	34	13 (5 to 30)	10	10	0 (0 to 28)
Set 2	30	34	13 (5 to 30)	10	10	0 (0 to 28)
Set 3	30	39	30 (17 to 48)	10	10	0 (0 to 28)
Set 4	30	29	3 (0.6 to 17)	10	10	0 (0 to 28)
Experiment 3						
Zero leak	100	118	18 (12 to 27)			
Minimal leak	100	86	14 (9 to 22)			
Moderate leak	100	0	0 (0 to 4)			
Large leak	100	0	0 (0 to 4)			

Experiment 1, low-pressure bench test; Experiment 2, high-pressure bench test; and Experiment 3, simulated leak bench test. LVR, lung volume recruitment.

#### Experiment 4: LVR counter accuracy in a healthy control participant

The performance of the LVR counter sampling at 1, 2 and 4 Hz in a healthy volunteer is reported in [table 3](#). Under all conditions, the device was able to detect that a session of LVR, comprising three sets of three repetitions, had been conducted; however, individual compressions were missed at lower sampling frequencies.

#### Experiment 5: LVR ‘in the field’

Data from 16 participants (960 possible participant days) were analysed. A total of 933 diary reports and 880 LVR counter records were collected, with paired data available for 853 participant days. One participant lost his LVR kit, and two LVR counters malfunctioned for a period of

time. All participants or their carers were able to successfully turn the LVR counter on and off.

There was substantial agreement between the number of sessions recorded per day (77% agreement, weighted Cohen’s  $K=0.66$ ,  $p<0.0005$ ; [table 4](#)). The highest concordance was demonstrated when two sessions per day were recorded in both the diary and the LVR counter. Disagreement typically favoured more sessions reported in the diary (18%) versus LVR counter recordings (5%).

#### DISCUSSION

This study describes the validation and use of an LVR counter, retrofitted onto a commercially available LVR kit, to objectively quantify an individual’s concordance with prescribed LVR therapy. The minimum pressure

**Table 3** Number of compressions recorded by the LVR counter, at three different sampling rate conditions, in a healthy volunteer

Sampling rate (Hz)		Compressions		Accuracy	
		Manual count	LVR counter	Total compressions	Total repetitions
4	Set 1	2 : 3 : 4	2 : 3 : 4	27/27 (100%)	9/9 (100%)
	Set 2	2 : 3 : 4	2 : 3 : 4		
	Set 3	2 : 3 : 4	2 : 3 : 4		
2	Set 1	2 : 3 : 4	2 : 3 : 4	25/27 (93%)	9/9 (100%)
	Set 2	2 : 3 : 4	2 : 3 : 4		
	Set 3	2 : 3 : 4	2 : 2 : 3		
1	Set 1	2 : 3 : 4	2 : 2 : 4	16/27 (59%)	9/9 (100%)
	Set 2	2 : 3 : 4	1 : 2 : 2		
	Set 3	2 : 3 : 4	1 : 1 : 1		

Where x : y : z represents the number of compressions per repetition within each set. Shaded cells indicate discrepancy between delivered compressions and LVR counter recordings. Hz, hertz; LVR, lung volume recruitment.

**Table 4** Agreement matrix of lung volume recruitment (LVR) therapy sessions recorded by the LVR counter compared with participant diary, for 16 people with neuromuscular disease in a community setting

	Diary: reported sessions					Total
	0	1	2	3	4	
LVR counter: recorded sessions						
0	138	36	35	1	0	210
1	12	80	74	1	1	168
2	5	11	433	9	0	458
3	1	1	12	2	0	16
4	0	0	1	0	0	1
Total	156	128	555	13	1	853

Shaded cells represent concordance between diary and LVR counter.

required to trigger the LVR counter's pressure switches under conditions of zero leak was 1.9 cm H<sub>2</sub>O, suggesting that it is extremely sensitive in detecting usage (Experiment 1). The LVR counter is accurate at detecting single compressions of the LVR bag in a controlled setting, with the LVR counter recording 98% of all compressions at low pressure (Experiment 2). The in-series design of the LVR counter ensured that both a compression of the bag *and* adequate participant seal must simultaneously occur for use to be recorded (Experiment 3).

Although the LVR counter overestimated the count of individual compressions delivered to the test lung under high-pressure bench test conditions (up to 100 cm H<sub>2</sub>O) by 15%, it demonstrated 100% accuracy in counting all 40 repetitions. Arguably, the 'overcounting' of compressions is of little clinical importance because compressions are simply the mechanism by which one achieves the clinically important outcome; the attainment of the therapeutically targeted maximal tolerated insufflation capacity (MIC or LIC); and the repetition, sets and sessions that sum to provide the daily dose of LVR therapy (figure 2). Physiological control testing (Experiment 4) similarly demonstrated 100% accuracy between repetitions and sets of LVR therapy conducted and recorded, regardless of the speed at which the technique was performed. Increasing the LVR counter's sampling rate to 4 Hz recorded compressions precisely, and therefore, if required perhaps for research applications, both compressions and repetitions may be recorded with higher fidelity.

The use of this LVR counter in the community appeared feasible; data were obtained for 92% participant days (880 out of a possible 960). Of the 853 sets of paired data, there was absolute agreement regarding the daily dose between the LVR counter and self-report diary 77% of the time (653 instances). Greater discordance in the direction of the diary suggests overestimation of self-reported LVR usage, a common finding in other chronic conditions when self-report measures have been

compared with objective measures of use.<sup>26,27</sup> In one study, 47% of people with cystic fibrosis reported performing more airway clearance therapy sessions than objectively recorded data would suggest across a 5-week period.<sup>26</sup> In contrast, medication adherence literature would indicate better concordance, with 72% of studies reporting 'high' concordance; high concordance is defined as <10% difference between self-reported diary and other measures of adherence.<sup>27</sup> Differences in concordance rates between self-reported and objective measures may be related to the type of intervention (eg, ease and time required to perform), duration of follow-up period and participant awareness of monitoring.

A limitation of the way the LVR counter was used in our field testing was that it needed to be manually switched 'on' before each therapy session. This approach was taken to ensure adequate battery life as the LVR counters' data were downloaded only once a month. As such, forgetting to start the counter before each therapy session would lead to an under-recording of LVR usage and could partially explain the apparent overestimation on the diary. Anecdotal participant reports confirmed this, but there was no suggestion this accounted for all discordant data. In 5% of cases, we identified a therapy session had been recorded on the LVR counter and not documented in the diary. Given the LVR counter's design, we suggest that when discordance favours the LVR counter, this represents actual usage and a conservative but accurate representation of 'at least' delivered dose.

The ability to objectively monitor therapy use, dosage or concordance with recommended prescription is much needed; examining dose-response is vital to assess the efficacy of LVR therapy and establish empirically derived optimal dose recommendations. Moreover, monitoring of treatment data including therapy use has been shown to improve adherence to continuous positive airway pressure treatment, when part of a multimodal intervention strategy in people with obstructive sleep apnoea.<sup>30</sup> To date, evidence of effectiveness of LVR is largely limited to retrospective cohort design or prospective studies with only participant self-report of use. In other conditions, this has been shown to be inaccurate, and hence, translation of these studies into practice and policy is compromised. Reports of little or no therapeutic benefit may reflect non-performance of treatment or a true lack of effect, but without objective usage data, it is not possible to know. The ability to correlate clinically important outcomes with a specific threshold of utilisation will assist in clinical prescription so as not to overburden or undertreat individuals. The requirement for both pressure switches to be triggered during the manoeuvre is a strength of the design of this LVR counter. This guards against usage being recorded when the LVR bag is compressed but not connected to the person (ie, simulating usage or demonstrating the equipment). Similarly, ineffective therapy due to interface leak is not counted as demonstrated by the lack of any recorded compressions in conditions with substantial leak.

## Limitations

There was no recording of the flow or volume delivered during LVR nor any external criterion measure of use during field testing (Experiment 5); we were comparing the new LVR counter to self-report. While the performance of the LVR counter in the preceding bench tests strongly suggests that the LVR counter accurately records repetitions, sets and thus sessions and daily dose, there is a possibility that the self-report data were ‘more true’ than the LVR counter. As noted, previous literature in other self-report versus objective measurement conditions would make this possibility unlikely.<sup>26 27</sup> The LVR counter used in this project is an in-house-developed prototype and as such does not provide a clear pathway to commercial and clinical translation of our findings; however, we suggest that this paper illustrates clear translational opportunities. Clinically, objective data provide opportunities for home monitoring of therapy, may suggest poor usage and may prompt clinicians to identify barriers to treatment, and similarly, patterns of use may provide important information about users’ beliefs and treatment choices, both positive and negative. As with continuous positive airway pressure therapy for sleep apnoea,<sup>31</sup> demonstrating sufficient LVR use could be linked to funding of LVR therapy, potentially providing a commercialisation pathway for device development.

## CONCLUSION

The LVR counter has been tested in both the laboratory and community settings and appears to be an effective usage monitor for both clinical and research purposes. Usage data that are more objective than the previous standard of self-report provide future research opportunities into the effectiveness of LVR treatment, prophylaxis and dose responsiveness.

## Author affiliations

- <sup>1</sup>Institute for Breathing and Sleep, Heidelberg, Victoria, Australia
- <sup>2</sup>Physiotherapy, Austin Health, Heidelberg, Victoria, Australia
- <sup>3</sup>Physiotherapy, The University of Melbourne, Melbourne, Victoria, Australia
- <sup>4</sup>Respiratory and Sleep Medicine, Austin Health, Heidelberg, Victoria, Australia
- <sup>5</sup>Medicine, University of Ottawa, Ottawa, Ontario, Canada
- <sup>6</sup>Respiratory Medicine, Ottawa Hospital Rehabilitation Centre, Ottawa, Ontario, Canada
- <sup>7</sup>Ottawa Hospital Research Institute, Ottawa, Ontario, Canada
- <sup>8</sup>Respiratory Medicine, Children’s Hospital of Eastern Ontario, Ottawa, Ontario, Canada
- <sup>9</sup>Children’s Hospital of Eastern Ontario Research Institute, Ottawa, Ontario, Canada

**Acknowledgements** The authors gratefully acknowledge the assistance of Mr Joao Tomas (rehabilitation engineering department, the Ottawa Hospital Rehabilitation Centre, Ottawa, Canada) in developing the LVR counter and Dr Warren Ruehland and Ms Krishna Saravanan (Institute for Breathing and Sleep, Melbourne, Australia) for the development of the LVR counter Excel macro and with figure illustrations.

**Contributors** NS, DJB, MEH, DAM and SLK contributed to the study design. PEN, NS, DAM and SLK contributed to the data collection. All authors contributed to the statistical analysis and manuscript drafting and gave approval for the final manuscript as submitted.

**Funding** The study was supported by funding from Children’s Hospital of Eastern Ontario Summer Studentship Grant, National Health and Medical Research Council

Postgraduate Scholarship (NS), Motor Neurone Disease Research Institute of Australia Grant-In-Aid, Institute for Breathing and Sleep Research Grant and a Physiotherapy Research Foundation Seeding Grant.

**Competing interests** None declared.

**Patient consent for publication** Not required.

**Provenance and peer review** Not commissioned; externally peer reviewed.

**Data availability statement** Data are available upon reasonable request from the corresponding author

**Supplemental material** This content has been supplied by the author(s). It has not been vetted by BMJ Publishing Group Limited (BMJ) and may not have been peer-reviewed. Any opinions or recommendations discussed are solely those of the author(s) and are not endorsed by BMJ. BMJ disclaims all liability and responsibility arising from any reliance placed on the content. Where the content includes any translated material, BMJ does not warrant the accuracy and reliability of the translations (including but not limited to local regulations, clinical guidelines, terminology, drug names and drug dosages), and is not responsible for any error and/or omissions arising from translation and adaptation or otherwise.

**Open access** This is an open access article distributed in accordance with the Creative Commons Attribution Non Commercial (CC BY-NC 4.0) license, which permits others to distribute, remix, adapt, build upon this work non-commercially, and license their derivative works on different terms, provided the original work is properly cited, appropriate credit is given, any changes made indicated, and the use is non-commercial. See: <http://creativecommons.org/licenses/by-nc/4.0/>.

## ORCID iD

David J Berlowitz <http://orcid.org/0000-0003-2543-8722>

## REFERENCES

- 1 Molgat-Seon Y, Hannan LM, Dominelli PB, *et al*. Lung volume recruitment acutely increases respiratory system compliance in individuals with severe respiratory muscle weakness. *ERJ Open Res* 2017;3:00135-2016-2016.
- 2 Katz SL, Barrowman N, Monsour A. Long-term effects of lung volume recruitment on maximal inspiratory capacity and vital capacity in Duchenne muscular dystrophy. *Ann Am Thorac Soc* 2016;13:217-22.
- 3 McKim DA, Katz SL, Barrowman N, *et al*. Lung volume recruitment slows pulmonary function decline in Duchenne muscular dystrophy. *Arch Phys Med Rehabil* 2012;93:1117-22.
- 4 Toussaint M, Pernet K, Steens M, *et al*. Cough augmentation in subjects with Duchenne muscular dystrophy: comparison of air stacking via a resuscitator bag versus mechanical ventilation. *Respir Care* 2016;61:61-7.
- 5 Marques TBC, Neves JdeC, Portes LA, *et al*. Air stacking: effects on pulmonary function in patients with spinal muscular atrophy and in patients with congenital muscular dystrophy. *J Bras Pneumol* 2014;40:528-34.
- 6 Kaminska M, Browman F, Trojan DA, *et al*. Feasibility of lung volume recruitment in early neuromuscular weakness: a comparison between amyotrophic lateral sclerosis, myotonic dystrophy, and postpolio syndrome. *Pm R* 2015;7:677-84.
- 7 Sancho J, Servera E, Diaz J, *et al*. Efficacy of mechanical insufflation-exsufflation in medically stable patients with amyotrophic lateral sclerosis. *Chest* 2004;125:1400-5.
- 8 Kang SW, Bach JR. Maximum insufflation capacity: vital capacity and cough flows in neuromuscular disease. *Am J Phys Med Rehabil* 2000;79:222-7.
- 9 Bach JR, Mahajan K, Lipa B, *et al*. Lung insufflation capacity in neuromuscular disease. *Am J Phys Med Rehabil* 2008;87:720-5.
- 10 Torres-Castro R, Vilaró J, Vera-Urbe R, *et al*. Use of air stacking and abdominal compression for cough assistance in people with complete tetraplegia. *Spinal Cord* 2014;52:354-7.
- 11 Bach JR. Mechanical insufflation-exsufflation. Comparison of peak expiratory flows with manually assisted and unassisted coughing techniques. *Chest* 1993;104:1553-62.
- 12 Toussaint M, Boitano LJ, Gathot V, *et al*. Limits of effective cough-augmentation techniques in patients with neuromuscular disease. *Respir Care* 2009;54:359-66.
- 13 Senent C, Golmard J-L, Salachas F, *et al*. A comparison of assisted cough techniques in stable patients with severe respiratory insufficiency due to amyotrophic lateral sclerosis. *Amyotroph Lateral Scler* 2011;12:26-32.
- 14 Kang SW, Kang YS, Moon JH, *et al*. Assisted cough and pulmonary compliance in patients with Duchenne muscular dystrophy. *Yonsei Med J* 2005;46:233-8.



- 15 Ishikawa Y, Bach JR, Komaroff E, *et al.* Cough augmentation in Duchenne muscular dystrophy. *Am J Phys Med Rehabil* 2008;87:726–30.
- 16 Brito MF, Moreira GA, Pradella-Hallinan M, *et al.* Air stacking and chest compression increase peak cough flow in patients with Duchenne muscular dystrophy. *J Bras Pneumol* 2009;35:973–9.
- 17 Kang S-W, Kang Y-S, Sohn H-S, *et al.* Respiratory muscle strength and cough capacity in patients with Duchenne muscular dystrophy. *Yonsei Med J* 2006;47:184–90.
- 18 Chatwin M, Toussaint M, Gonçalves MR, *et al.* Airway clearance techniques in neuromuscular disorders: a state of the art review. *Respir Med* 2018;136:98–110.
- 19 Srour N, LeBlanc C, King J, *et al.* Lung volume recruitment in multiple sclerosis. *PLoS One* 2013;8:e56676.
- 20 Rafiq MK, Bradburn M, Proctor AR, *et al.* A preliminary randomized trial of the mechanical insufflator-exsufflator versus breath-stacking technique in patients with amyotrophic lateral sclerosis. *Amyotroph Lateral Scler Frontotemporal Degener* 2015;16:448–55.
- 21 Kang SW, Bach JR. Maximum insufflation capacity. *Chest* 2000;118:61–5.
- 22 Chiou M, Bach JR, Jethani L, *et al.* Active lung volume recruitment to preserve vital capacity in Duchenne muscular dystrophy. *J Rehabil Med* 2017;49:49–53.
- 23 Birnkrant DJ, Bushby K, Bann CM, *et al.* Diagnosis and management of Duchenne muscular dystrophy, part 2: respiratory, cardiac, bone health, and orthopaedic management. *Lancet Neurol* 2018;17:347–61.
- 24 McKim DA, Road J, Avendano M, *et al.* Home mechanical ventilation: a Canadian thoracic Society clinical practice guideline. *Can Respir J* 2011;18:197–215.
- 25 Bott J, Blumenthal S, Buxton M, *et al.* Guidelines for the physiotherapy management of the adult, medical, spontaneously breathing patient. *Thorax* 2009;64 Suppl 1:i1–52.
- 26 Oates GR, Stepanikova I, Rowe SM, *et al.* Objective versus self-reported adherence to airway clearance therapy in cystic fibrosis. *Respir Care* 2019;64:176–81.
- 27 Garber MC, Nau DP, Erickson SR, *et al.* The concordance of self-report with other measures of medication adherence: a summary of the literature. *Med Care* 2004;42:649.
- 28 Toussaint M, Chatwin M, Gonzales J, *et al.* 228th ENMC International workshop: airway clearance techniques in neuromuscular disorders Naarden, the Netherlands, 3-5 March, 2017. *Neuromuscul Disord* 2018;28:289–98.
- 29 Sheers N, Howard ME, Ruehland WR. Excel macro for lung volume recruitment CounterData (omega data logger). (version 1.0). Zenodo, 2021. Available: <http://doi.org/10.5281/zenodo.4587974>
- 30 Sawyer AM, Gooneratne NS, Marcus CL, *et al.* A systematic review of CPAP adherence across age groups: clinical and empiric insights for developing CPAP adherence interventions. *Sleep Med Rev* 2011;15:343–56.
- 31 . Available: [http://www.enable.health.nsw.gov.au/\\_\\_data/assets/pdf\\_file/0004/262615/Adult-CPAP-Funding-Criteria.pdf](http://www.enable.health.nsw.gov.au/__data/assets/pdf_file/0004/262615/Adult-CPAP-Funding-Criteria.pdf)