

## RESEARCH ARTICLE

# Clinical teaching behaviour effects professional identity and transition shock in new nurses in western china: A cross-sectional study

Qian Su<sup>1,2</sup>  | Bei YUN<sup>3</sup> | Loretta Yuet Foon Chung<sup>3</sup> | Lian Chen<sup>3</sup> | Yamei Zuo<sup>3</sup> | Jia Liu<sup>2</sup> | Lin Han<sup>2,3</sup> 

<sup>1</sup>The First Clinical Medical College, Lanzhou University, Lanzhou, China

<sup>2</sup>Nursing Department, Gansu Provincial Hospital, Lanzhou, China

<sup>3</sup>School of Nursing, Lanzhou University, Lanzhou, China

## Correspondence

Lin Han, School of Nursing, Lanzhou University, Lanzhou, China.  
Email: hanlindoudou@163.com

## Funding information

the Fundamental Research Funds for the Central Universities, Grant/Award Number: lzujbky-2016-ct14 and lzujbky-2018-ct05; Scientific Research Project of health industry in Gansu Province, Grant/Award Number: GSWSKY-2019-41

## Abstract

**Aim:** To examine the interrelationship between professional identity, clinical teaching behaviour and transition shock for new nurses in Western China.

**Design:** A cross-sectional design.

**Methods:** A total of 779 new nurses were recruited in Gansu province and Lanzhou city from June to July 2019. Each patient was given three questionnaires to complete, and structural equation modelling was used to identify the relationships.

**Results:** The overall mean scores for the transition shock, professional identity and clinical teaching behaviour were 92.53( $SD = 22.17$ ), 89.74( $SD = 16.57$ ) 80.12( $SD = 12.38$ ), respectively. The most important aspects identified were the Physical aspect, the Sense of Mastery and Committing to Teaching. Professional identity and clinical teaching behaviour were negatively related to transition shock, a better sense of identity coupled with supportive clinical teaching were keys to a smoother journey from new to experienced nurses.

## KEYWORDS

clinical teaching behaviour, new nurses, professional identity, transition shock

## 1 | INTRODUCTION

With the world population ageing and cases of new non-communicable diseases increasing globally, more number of nurses are required to promote awareness for health and disease prevention and to provide care for the affected people (Crisp & Iro, 2018). Unfortunately, the retention of the nursing workforce is an important issue for nursing staff managers all around the world (Ahlstedt et al., 2019). China, with the largest population in the world, is facing unprecedented challenges in an already overburdened healthcare system because of the ageing population (Wang & Chen, 2014). The

national nurse to bed ratio for China is around 0.45 which is far lower than that of Europe (1.25). This points towards a shortage of nursing staff in China (Zeng et al., 2018). Escalating levels of patient aspects and consequential nursing workload create a burdened environment for the newly recruited nurses that essentially lack the practical expertise and the confidence to navigate through the dynamic and intense clinical environment. This makes the transition phase of new nurses a considerable challenge for them and their recruiters (Duchscher, 2009).

Professional identity, a deeply rooted self-concept with the nursing profession, is an individual's understanding of the social impact

Qian SU and Bei YUN should be considered joint first authors; they contribute equally to this article

This is an open access article under the terms of the Creative Commons Attribution-NonCommercial-NoDerivs License, which permits use and distribution in any medium, provided the original work is properly cited, the use is non-commercial and no modifications or adaptations are made.

© 2021 The Authors. *Nursing Open* published by John Wiley & Sons Ltd.

of their profession and the significance of their work. It serves as a psychological basis for people to do their job well and achieve the organizational goal (Moore & Hofman, 1988). The development of professional identity is a dynamic process and gives meaning and orientation to one's profession. Linking professional identity with the job role clears an individual's perceptions including professional interests, skills, aims and values (Hirschi, 2012).

According to the "Chinese nursing development plan (2016–2020)" and "Training Syllabus for New Nurses," it is mandatory to increase the standardized training of new nurses to improve nursing as a profession and ameliorate their service quality. The standardized training time for new nurses in China is 1–3 years. In our study, we have selected those nurses as patients who have served for 1–3 years in this profession.

## 2 | BACKGROUND

With the current healthcare environment undergoing rapid and complex changes, the transition phase proves quite challenging for the newly recruited nurses. This challenge experienced by new nurses in their transition from new nurses to experienced nurses is termed as transition shock. This transition shock experienced by the new nurses emerges as a consequence of moving from the university to an unfamiliar clinical practice environment (Duchscher, 2008). Due to the inconsistency between the expected and the real working environment, new nurses experience a variety of emotions related to the transition shock such as doubt, confusion and sometimes even depression as well (Duchscher, 2008). Transition shock is the most immediate, acute and dramatic stage in the process of adapting to the professional role of a nurse (Duchscher, 2009). Almost all the new nurses experience transition shock, but the severity varies (Kramer et al., 2013). Upon experiencing a transition shock, the new nurses go through a process of adapting to the clinical practice by reassessing and re-building their professional identity (Duchscher, 2009). In cases where they cannot overcome the transition shock, the nurses may face emotional burnout at the beginning of the employment often leading to their resignation (Beecroft et al., 2001; Martin, 2011; Suzuki et al., 2006). During the initial 12 months of employment, all nurses face troubles due to a lack of clinical knowledge and confidence in performing their skills. They also face challenges that revolve around building relationships with their colleagues, high workload demands, organization and prioritization related to decision-making, direct care judgements and communicating with physicians.

The nurses transitioning from the roles of a new nurse to an experienced one also undergo a second transition comprising of feelings of role ambiguity, anxiety and stress (Barnes, 2015a, Barnes, 2015b; Poronsky, 2012). Building a successful professional identity is being formatted by the periods of transition for individual nurses. It widely depends on the person's aspects of attitude, beliefs, behaviours and attainment of the required knowledge for developing capabilities

that support the roles and responsibilities of the nursing profession (Johnson et al., 2012; Trede et al., 2012). Signifying positive feedback, a successful transition, and the development of an acceptable professional identity leads to greater professional satisfaction and decreases transition shock for the nurses (Sabanciogullari & Dogan, 2015; Trede et al., 2012).

As soon as the new nurses begin their careers, they immediately start managing nursing care for patients with multiple complexities. At the same time, they also start managing their day-to-day responsibilities (Acuna et al., 2017; McCalla-Graham & De Gagne, 2015), which include working with family members and documenting office work, and getting acquainted with the culture of the nursing department. These responsibilities are quite different from what is usually asked of student nurses. They generally have little to no practical nursing experiences and lack social and developmental maturity making them vulnerable to the struggle with the management of the basic clinical work (Duchscher, 2008). Nurses experience transition shock when they realize the difference between their known role as student nurses and the demanding role of experienced nurses. Experienced nurses are far more competent and knowledgeable in concerned areas such as maintaining patient relationships, managing their information and delivering performances at par with the expectations (Clipper & Cherry, 2015; Duchscher, 2009). However, this whole set-up is very stressful for the newly recruited nurses (Clipper & Cherry, 2015; Kelly & McAllister, 2013; Kumaran & Carney, 2014).

As socialization is a practiced norm in the nursing department, the whole precepted clinical experience gives a work-integrated learning opportunity to the new nurses (Lee-Hsieh et al., 2016). Moreover, the preceptors can help the new nurses to have a smooth and successful role transition into experienced nurses. Preceptors in the nursing department, with effective clinical teaching behaviour, can help the new nurses to develop unit-specific competence and increase their confidence levels, incur satisfaction and decrease their tendency for transition shock (Haggerty et al., 2013).

Based on the above studies, it becomes widely important to understand more about the relationship between professional identity and transition shock for new nurses. As precepted learning augments better transitioning in new nurses, it becomes equally important to explore the role of clinical teachers or preceptors as mediators between professional identity and transition shock.

## 3 | THE STUDY

### 3.1 | Design

A cross-sectional design was adopted for the study where we collected a sample of 800 new nurses, recently recruited in eight hospitals of Gansu province and Lanzhou city. New nurses who met the following inclusion criteria were included in the study: (a) Graduated from a college or university and obtained the diploma; (b) Passed the nurse qualification examination; (c) Selected in top three hospitals in 2016.

## 3.2 | Questionnaires

### 3.2.1 | Demographic Questionnaire

The demographic characteristics include age, gender, education level, marital status, working time, professional title, training for new nurses, classification of the department, pre-service training, teaching method, independent nursing work and whether the first major is nursing or not.

### 3.2.2 | The Clinical Teaching Behavior Inventory (CTBI-23)

We also investigated the clinical teaching behaviour of the preceptors using the questionnaire developed by a Taiwan scholar in 2016, namely the Clinical Teaching Behavior Inventory (Lee-Hsieh et al., 2016). This scale contains 23 items that are evenly distributed over the following six dimensions: Commitment to teaching (CT); Building a learning atmosphere (LA); Using appropriate teaching strategies (TS); Guiding inter-professional communication (IC); Providing feedback and evaluation (FE); and Showing concern and support (CS).

All items of CTBI-23 are positively stated. The total mean score is calculated by averaging the sum score of all items. Each item score ranges from 1–5 (1 as strongly disagree to 5 as strongly agree); thus, the total possible score on the CTBI-23 ranges from 23–115. The higher the score, the more positive is a student's perception of the clinical teaching behaviour. The value of Cronbach's coefficient ( $\alpha$ ) was 0.96, and for the six domains, the values range from 0.80–0.86. Quite uniquely, the subject of the CTBI id is "I" for the preceptor self-evaluation, while for evaluating the preceptor as a teacher the subject is changed to "preceptor."

### 3.2.3 | The Transition Shock of Newly Graduated Nurses Scale (TSNGNS)

The scale used for measuring transition shock for new nurses was developed by Xue Youru (Xue. Y. R., et al., 2015a). The scale consists of 27 items categorized into 4 dimensions, namely (a) physical aspects, (b) psychological aspects, (c) knowledge and skills and (d) social culture and development. The TSNGNS scores are computed as the sum of the 4 dimensions and vary between 27–135. On a 5-Likert scale, responses range from 1 as completely disagree to 5 as completely agree. The higher the score is, the more serious the impact of the transformation is. The value of Cronbach's  $\alpha$  coefficient was recorded as 0.918, and the content validity was 0.906.

### 3.2.4 | Nurse's Career Identity Scale

The Scale was translated into Chinese version (Zhao. H. et al., 2010), which consists of 21 items categorized into 5 dimensions: (1) the

sense of self-efficacy and mastery, (2) sense of consistency, (3) sense of self-determination, (4) sense of patient and organizational influence and (5) sense of meaning. On a 5-Likert scale, responses range from 1 as completely disagree to 5 as completely agree. The scale for scores is computed as the sum of 5 dimensions and varies between 21–105. The higher the score, the stronger the career identity. The value of Cronbach's  $\alpha$  coefficient was 0.902, and the scale for each dimension ranged from 0.734–0.854. Due to the different items representing each dimension of the scale, the scores are converted into percentages for easy comparison and analysis. The formula used is as follows: Score rate of the total score (or scores of each dimension)/full score of the scale (or full score of each dimension)  $\times$  100%.

## 3.3 | Data collection

The data for the study were collected from June to July 2019. After obtaining consent from the director of the hospital's nursing department, new nurses who met the inclusion criteria were selected. Researchers asked the participants to gather in a conference room and delivered the online questionnaires to them via an APP called "Wen Juanxing." Through this APP, the questionnaires were converted into electronic questionnaires, which needed to be filled and submitted online. The online questionnaire was set to mandatory completion of all items before submitting to avoid incomplete submissions and it took around 15–20 min for the patients to fill the questionnaire. In addition, push notifications were sent three times during this time to remind the new nurses about the completion of the electronic questionnaires. Among the 800 questionnaires that were returned, responses in 21 questionnaires were invalid, hence excluded from this study. Only the completed questionnaires were taken for further evaluation. After all necessary checks, questionnaires from 779 new nurses (97.38%) were included for statistical analysis.

## 3.4 | Data analysis

The study data were analysed using SPSS 25.0 and AMOS 22.0. SPSS 25.0 was used to deal with descriptive statistics, independent-samples *t* test, a one-way analysis of moment structure (ANOVA), and Pearson's correlation. AMOS was used to estimate structural equation modelling (SEM).

Researchers used independent-samples *t* test and ANOVA to test the differences in transition shock in terms of demographic characteristics and used Pearson's correlation to determine the direction and size of the relationships among transition shock, clinical teaching behaviour and professional identity.

Structural equation modelling was used to test the hypothesized model, which is a confirmatory approach towards testing. The hypothesized model was based on a previous theory or experience about the variables in the model. Our hypothesized model included three latent variables: professional identity as an

independent variable, clinical teaching behaviour as a mediator variable and transition shock as the outcome variable. Researchers used *SEM* with the maximum likelihood to ascertain relationships and predictions among transition shock, clinical teaching behaviour and professional identity. The study considered measurement errors of *SEM* during the analyses. The goodness fit of *SEM* was evaluated by the likelihood ratio ( $\chi^2/df$ ) values being lower than 5, the goodness of fit index (GFI), the comparative fit index (CFI) and Tucker-Lewis fit index (TLI) values were higher than 0.90, and root means the square error of approximation (RMSEA) values were lower than 0.08.

### 3.5 | Validity and reliability

All the questionnaires used in this study have been validated in previous research. The Clinical Teaching Behavior Inventory showed a Cronbach's  $\alpha$  of 0.96. The Cronbach's  $\alpha$  coefficient of Transition Shock of Newly Graduated Nurses Scale was 0.918 and the content validity was 0.906, whereas the Cronbach's  $\alpha$  coefficient of Nurse's Career Identity Scale was 0.902 and each dimension ranged from 0.734–0.854.

## 4 | ETHICAL CONSIDERATION

The study was approved by the Medical Ethics Committee, School of Nursing, Lanzhou University (No. HLLL20191218). Researchers visited the nursing departments of eight hospitals, explained the purpose and method of the research and received permission from the director of the hospital's nursing department. Additionally, informed consent was also obtained from the participants.

## 5 | RESULTS

### 5.1 | Demographic characteristics and transition shock

The new nurses had an average age of 25.41 ( $SD = 1.89$ , range 20–29). The patients were had a majority of females (716, 91.9%) with a small proportion of male nurses (63, 8.1%). Of all participants, most had received senior high school education (479, 61.5%), followed by graduate education (290, 37.2%). 73.5% (572) of the patients were unmarried. The participants of new nurses recruited in 2017 were 292 (37.5%), while new nurses of grade 1 (with the job title as “nurses,” not “nursing teacher”) were 665 (85.5%). 668 (85.8%) of the new nurses chose nursing as their first major in the university, and 641 (82.4%) had done nursing work independently. Hospitals implemented standard training for the majority of the new nurses (713, 91.5%), whereas most of them did not experience any pre-job training (725.93.1%). A good number of preceptors used a one-to-one teaching method for new nurses (548, 70.3%).

The mean total transition shock score was 92.53 out of 135. There were statistically significant differences due to age, the hospital implemented training, classification of departments and nursing as their first major on transition shock ( $p < .05$ ). There were no other demographic differences in transition shock ( $p > .05$ ) (see Table 1).

### 5.2 | Clinical teaching behaviour, professional identity and transition shock

Table 2 shows the means, standard deviations and correlations among the related variables. The overall mean scores for the Transition Shock of Newly Graduated Nurses Scale, Nurse's Career Identity Scale and Clinical Teaching Behavior Inventory were 92.53 ( $SD = 22.17$ ), 89.74 ( $SD = 16.57$ ) and 80.12 ( $SD = 12.38$ ), respectively, and their score rates were 68.54%, 76.3% and 78.03%, respectively. In addition, the scoring rates for the dimensions of transition shock, from high to low, were measured as follows: physical aspect (77.87%), psychological aspect (69.45%), knowledge and skills (67.48%) and social culture and development (61.30%). The scoring rate for dimensions of professional identity, from high to low, was recorded as follows: the sense of mastery (87.67%), sense of self-efficacy (81.73%), sense of consistency (81.13%), sense of self-significance (79.73%), sense of self-determination (76.27%), sense of patient influence (66.40%) and sense of organization influence (61.20%). The scoring rate for dimensions of the clinical teaching behaviour, as documented from high to low, was found to be as follows: committing to teaching (80.10%), providing feedback and evaluation (78.80%), using appropriate teaching strategies (78.64%), guiding inter-professional communication (78.13%), showing concern and support (76.73%) and building a learning atmosphere (76.00%). Professional identity and clinical teaching behaviour cause statistically significant differences in an individual's experience of transition shock. Transition shock had a significant negative correlation with the clinical teaching behaviour ( $r = -0.184$ ,  $p < .01$ ), which means that as clinical teaching behaviour progressed in a better way, transition shock decreased significantly. Interestingly, transition shock had a negative correlation with professional identity ( $r = -0.070$ ,  $p = .05$ ). Simply put, transition shock tends to decrease and increase in professional identity. However, professional identity had a significant positive correlation with the clinical teaching behaviour ( $r = 0.511$ ,  $p < .01$ ) that is to say an increase was seen in professional identity whenever an increase was observed in clinical teaching behaviour.

### 5.3 | Moderating effects of clinical teaching behaviour on professional identity and transition shock

The *SEM* analysis of the effect of clinical teaching on professional identity and transition shock had a good fit of the data to the proposed model (Figure 1). In this study, the total effect was dissolved into a

**TABLE 1** Demographic characteristics and differences in transition shock (N = 779)

	N	Mean ± SD	t (F)	P
Gender				
Male	63(8.1)	93.13 ± 19.63	0.223	0.824
Female	716(91.9)	92.48 ± 22.39		
Age				
20–25	402(51.6)	90.21 ± 21.77	–3.033	0.002
2630	377(48.4)	95.01 ± 22.35		
Education level				
Bachelor	290(37.2)	94.81 ± 22.08	1.085	0.284
Senior high school	479(61.5)	91.29 ± 22.05		
Junior high school	10(1.3)	85.90 ± 26.86		
Marital status				
Divorced	1(0.1)	77 ± 00	0.985	0.524
Unmarried	572(73.5)	90.84 ± 21.64		
Married	206(26.4)	97.30 ± 23.00		
Working time				
4	192(24.6)	94.61 ± 22.63	1.133	0.193
3	292(37.5)	91.51 ± 20.95		
2	244(31.1)	92.80 ± 22.73		
1	51(6.6)	89.27 ± 26.32		
Professional title				
Nurse	665(85.5)	92.07 ± 22.27	–1.26	0.208
Nurse practitioner	113(14.5)	94.90 ± 21.26		
Training for new nurses				
No	66(8.5)	85.83 ± 20.10	2.574	0.01
Yes	713(91.5)	93.15 ± 22.26		
Classification of department				
Paediatric	53(6.8)	100 ± 20.54	1.289	0.04
Maternity	54(6.9)	90.06 ± 21.22		
Emergency	48(6.2)	91.52 ± 20.56		
Outpatient	36(4.6)	91.97 ± 21.35		
Medicine	169(21.7)	93.77 ± 22.14		
Surgical anaesthesia	47(6.0)	97.30 ± 24.02		
surgical	176(22.6)	93.32 ± 21.53		
Medical technology	126(16.2)	89.19 ± 22.89		
Rehabilitation of traditional medicine	27(3.5)	88.85 ± 21.28		
Intensive care Unite	43(5.5)	86.40 ± 22.17		
Pre-service training				
No	54(6.9)	87.22 ± 21.27	1.826	0.068
Yes	725(93.1)	92.93 ± 22.20		
Teaching method				
Cross-teach	126(16.2)	97.81 ± 21.91	1.141	0.181
No	7(0.9)	116.57 ± 14.76		
Others	17(2.2)	99.76 ± 22.10		
Team teaching	81(10.4)	96.69 ± 22.44		
One-to-one	548(70.3)	90.17 ± 21.81		
Independent nursing work				
No	138(17.7)	85.92 ± 20.47	3.896	0.000
Yes	641(82.3)	93.95 ± 22.28		
First major is nursing				
No	111(14.2)	101.57 ± 19.30	–5.207	0.000
Yes	668(85.8)	91.03 ± 22.27		

**TABLE 2** Correlations between transition shock, clinical teaching behaviour and professional identity

	Mean ± SD	%	1	2	3	4	5	6	7	8
1. Trs	92.53 ± 22.17	68.54	1							
2.PHY	23.36 ± 5.26	77.87	0.829**	1						
3.PSY	27.78 ± 7.39	69.45	0.932**	0.709**	1					
4.KT	16.87 ± 4.42	67.48	0.848**	0.590**	0.757**	1				
5.SO	24.52 ± 7.77	61.30	0.923**	0.678**	0.796**	0.731**	1			
6.CTB	89.74 ± 16.57	78.03	-0.184**	-0.150**	-0.103**	-0.096**	-0.272**	1		
7.CT	16.02 ± 3.04	80.10	-0.205**	-0.152**	-0.133**	-0.110**	-0.294**	0.887**	1	
8.LA	19.00 ± 3.94	76.00	-0.147**	-0.122**	-0.069	-0.069	-0.232**	0.941**	0.822**	1
9.TS	19.66 ± 3.82	78.64	-0.183**	-0.159**	-0.099**	-0.096**	-0.265**	0.950**	0.792**	0.875**
10.IC	11.72 ± 2.37	78.13	-0.155**	-0.132**	-0.072*	-0.088*	-0.234**	0.927**	0.758**	0.826**
11.FE	11.82 ± 2.30	78.80	-0.182**	-0.140**	-0.109**	-0.108**	-0.259**	0.934**	0.775**	0.829**
12.CS	11.51 ± 2.43	76.73	-0.153**	-0.130**	-0.093**	-0.064	-0.223**	0.909**	0.753**	0.807**
13.PI	80.12 ± 12.38	76.30	-0.070	-0.016	-0.008	-0.076*	-0.139**	0.511**	0.461**	0.465**
14.SM	13.15 ± 1.84	87.67	-0.085*	0.008	-0.039	-0.110**	-0.149**	0.429**	0.374**	0.370**
15.SC	12.17 ± 2.11	81.13	-0.225**	-0.144**	-0.142**	-0.174**	-0.310**	0.490**	0.443**	0.432**
16.SS	11.96 ± 2.28	79.73	-0.192**	-0.118**	-0.110**	-0.132**	-0.287**	0.516**	0.473**	0.465**
17.SE	12.26 ± 1.99	81.73	-0.123**	-0.022	-0.084*	-0.125**	-0.184**	0.460**	0.436**	0.416**
18.SD	11.44 ± 2.54	76.27	-0.027	0.035	0.008	-0.068	-0.069	0.337**	0.312**	0.312**
18.OI	9.18 ± 3.12	61.20	0.049	0.017	0.084*	0.045	0.024	0.288**	0.264**	0.269**
20.PS	9.96 ± 2.98	66.40	0.120**	0.087*	0.138**	0.072*	0.111**	0.222**	0.176**	0.215**

Abbreviations: Trs: transition shock, PHY: physical aspect, PSY: psychological aspect, KT: knowledge and skills, SO: social culture and development, CTB: clinical teaching behavior inventory, CT: Committing to teaching, LA: Building a learning atmosphere, TS: Using appropriate teaching strategies, IC: Guiding inter-professional communication, FE: Providing feedback and evaluation, CS: Showing concern and support, PI: professional identity, SM: sense of mastery, SC: sense of consistency, SE: self-efficacy, SD: sense of self-determination, OI: sense of organizational influence, PS: sense of patient.

\* $p < .05$ ; \*\* $p < .01$ .

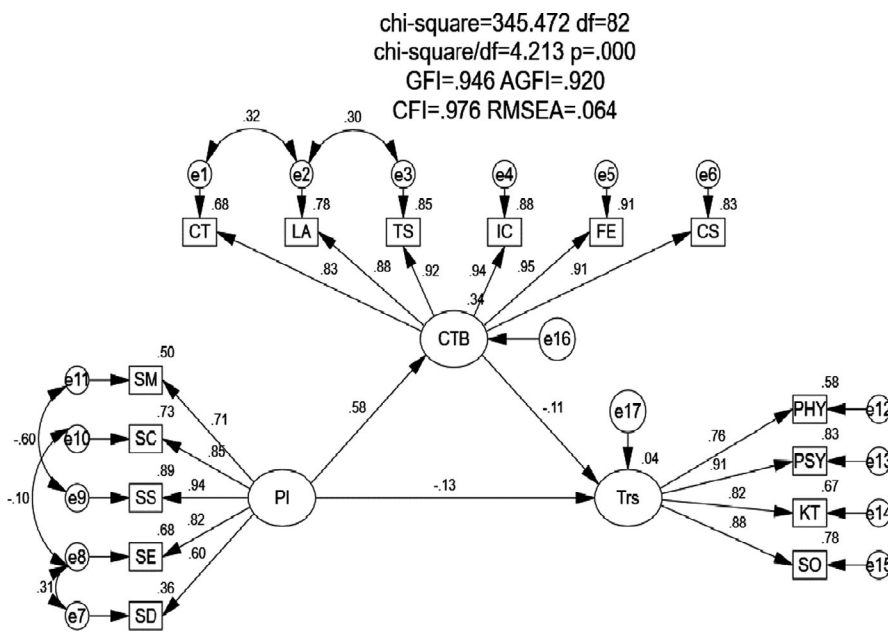

**FIGURE 1** Results of SEM analysis of the effect of clinical teaching behaviour on career identity and sense of transition shock among the whole sample

direct and an indirect effect on performing the effective decomposition of the path analysis. As shown in Figure 1, while the professional identity ( $\beta = -0.13, p < .01$ ) and clinical teaching behaviour were negatively correlated to transition shock ( $\beta = -0.11, p < .01$ ), the professional

identity was positively related to clinical teaching behaviour ( $\beta = 0.58, p < .01$ ). The results showed that clinical teaching behaviour moderated the effects of career identity and transition shock among new nurses. Two dimensions of Nurse's Career Identity Scale, the sense of

9	10	11	12	13	14	15	16	17	18	19	20
1											
0.875**	1										
0.870**	0.897**	1									
0.831**	0.844**	0.875**	1								
0.444**	0.484**	0.517**	0.501**	1							
0.404**	0.408**	0.448**	0.405**	0.641**	1						
0.438**	0.459**	0.507**	0.472**	0.755**	0.592**	1					
0.465**	0.474**	0.525**	0.486**	0.803**	0.520**	0.805**	1				
0.401**	0.426**	0.471**	0.428**	0.799**	0.580**	0.668**	0.776**	1			
0.286**	0.329**	0.335**	0.319**	0.784**	0.455**	0.495**	0.553**	0.632**	1		
0.236**	0.270**	0.279**	0.301**	0.724**	0.205**	0.319**	0.389**	0.374**	0.529**	1	
0.172**	0.224**	0.217**	0.255**	0.649**	0.240**	0.243**	0.282**	0.297**	0.376**	0.612**	1

TABLE 3 Direct and indirect effects in the model

Estimate	β	SE	BC 95% CI <sup>a</sup>	
			Lower	Upper
Total effects				
CTB <--- PI	0.581	0.031	0.519	0.639
Trs <--- CTB	-0.105	0.049	-0.197	-0.008
Trs <--- PI	-0.194	0.042	-0.277	-0.107
Direct effects				
CTB <--- PI	0.581	0.31	0.519	0.639
Trs <--- CTB	-0.105	0.049	-0.197	-0.008
Trs <--- PI	-0.133	0.51	-0.234	-0.032
Indirect effect				
Trs <--- PI	-0.061	0.028	-0.116	-0.005

Abbreviations: Trs: transition shock, CTB: clinical teaching behavior inventory, PI: professional identity.

<sup>a</sup>That 95% bias-corrected bootstrap confidence interval does not include zero means significant effects.

organizational influence and the sense of patient influence, had a poor correlation with professional identity (standard factor loading <0.5) as observed in this model. Keeping this in mind, we decided to delete two

dimensions in this model taking help from a previously published study (Polit et al., 2007).

### 5.4 | Direct and indirect effects

The direct effects of professional identity on clinical teaching behaviour and transition shock were tested for significance using the bootstrap estimation procedure (a bootstrap sample of 5,000 was specified). Table 3 shows the direct and indirect effects of the final model. The result showed that clinical teaching behaviour has significantly mediating effects in this model (95%CI = -0.116 to -0.005, *p* <.05) thus supporting our hypothesis that clinical teaching behaviour mediates the relationship between professional identity and transition shock.

## 6 | DISCUSSION

### 6.1 | The Transition Shock of Newly Graduated Nurses Scale

We investigated whether the clinical teaching behaviour had any effects on transition shock and professional identity. The mean

transition shock of new nurses was found to be  $92.53 \pm 22.17$ , which was lower than the result of the study ( $126.80 \pm 7.485$ ) (Xue, Y. R., et al., 2015b). It is quite possible that the impact on the transformation of new nurses was somehow also affected by the location of the hospital and the classification of their departments. Studies (Ho et al., 2009; Weng et al., 2010) have shown that there is no fixed transition period for a 1-year graduation internship. At the beginning of their work lives, new nurses always feel anxiety, tension and depression and have a lower professional identity. Furthermore, new nurses are always expected to do mechanical work and obey doctors' advice without much critical thinking. They lack communication skills and the capability to provide guidance for health. It is a possibility that their employer hospitals cannot provide or implement standard training procedures for them and they also did not get any chance to do nursing work independently. This concerns them about their competency levels in nursing thus making them under-confident in dealing independently with complex emergency incidences (Cline et al., 2017). Therefore, according to the results and reasons presented, nursing managers should take some serious measures to alleviate the transition shock faced by new nurses. For example, nursing managers should conduct communication skill courses or choose competent preceptors to teach new nurses.

The physical aspect of the transition shock refers to a series of physical changes experienced by new nurses in the transition period, such as physical exhaustion, sleep disturbance and malnutrition. The study shows that the physical aspect certainly ranks higher than other dimensions in the scale, followed by the psychological aspect. As also seen in previous studies, our results indicate that the transition shock imparts the biggest influence on the physical aspects of new nurses. For example, the new nurses' almost always experienced prolonged working time because of large workloads or a complicated task at hand. In addition, the frequent nursing shift leads to serious overdraft which easily results in physical fatigue, back pain, sleep disorders and other symptoms. To make it worse, the night shift nurses often work alone, which makes them face even more pressure (Chen et al., 2014; Fu et al., 2018). Compared with the day shift nurses, they are in a highly stressful state, making them exhausted both physically and psychologically (de Cordova et al., 2016; Kwak et al., 2018; Nowrouzi et al., 2016). In addition, it is difficult for shift nurses to balance their work, family and social life, and they often had to sacrifice rest-time to meet the requirements of their families and friends (Chen et al., 2014; de Cordova et al., 2016).

## 6.2 | Nurse's Career Identity Scale

The mean professional identity of new nurses was found to be 80.12, which was higher than previously reported (78.6) (Deng et al., 2013). The dimension of sense of mastery in the Nurse's Career Identity Scale was the highest, which meant that the sense

of mastery accounted for the largest proportion in the professional identity of new nurses. Sense of mastery means that the nurses are aware of their professional content and requirements, and their roles in the hospital. The possible reasons may be that with the continuous improvement of China's nursing education system, there is the strengthening of hospital managers' professional knowledge training for nurses. This resulted in the development of high-quality nursing service activities, giving the new nurses a much better understanding of a nurse's work and role in the hospital and the necessary requirement for professional knowledge and skills as required in this line of work. Moreover, we observed that as the dimension of sense of mastery increased, the transition shock decreased ( $t = -0.085$ ,  $p < .05$ ). Therefore, in order to decrease the transition shock for new nurses, nursing managers should strengthen professional knowledge training.

## 6.3 | Clinical teaching behavior inventory

New nurses indicated that preceptors were important in assisting them to bridge the gap between the theoretical aspects of nursing and the clinical practice by increasing their degree of knowledge and broadening their socialization circles, thus acting as a catalyst in making the new nurses an integral part of the nursing department (Powers et al., 2019; Ward & McComb, 2017). The mean of the Clinical Teaching Behavior Inventory, as evaluated by new nurses, was  $89.74 \pm 16.57$ , which was lower than that acquired by a previous study ( $97.90 \pm 12.564$ ; Lee-Hsieh et al., 2016). This discrepancy could be a result of including different hospitals of Lanzhou city in Gansu province and in Taiwan than those involved in our study. However, we got a similar highest trend for the value representing the dimension of commitment to teaching, like that obtained in a previous study (Lee-Hsieh et al., 2016; Powers et al., 2019). A preceptor's passion for teaching, a high tolerance for repeated instruction and professional nursing behaviours define what is called the dimension of commitment to teaching. This serves as a strong foundation on which the new nurses could contend to become better-experienced nurses (Lee-Hsieh et al., 2016). The senior preceptors had already acquired abundant clinical nursing experience and were full of passion for their nursing work. The preceptors had their own unique methods for teaching, in which they largely shared their work experiences with the new nurses and hence always conveyed a high enthusiasm for work which influenced the new nurses to work in the same way. Accordingly, we found that when the dimension of commitment to teaching was increased, the transition shock was decreased ( $t = -0.205$ ,  $p < .01$ ). In addition, the second dimension was providing feedback and evaluation, which meant preceptors helped them to correct their mistakes and improve their capability. Therefore, new nurses do believe that preceptors help them to build their confidence and lessen their anxiety, which enables them to be more independent (Powers et al., 2019; Ward & McComb, 2017).



## 6.4 | Correlations between transition shock, clinical teaching behaviour and professional identity

The results have shown that professional identity was negatively related to transition shock among new nurses, which supported the previous studies. For instance, the transition and change in professional identity from new nurses to experienced nurses could be stressful and lead to losing self-confidence and a sense of incompetence. In the first year, new nurses face the problem of transition and professional identity, which may cause them to leave their jobs (Barnes, 2015a; Cusson & Strange, 2008). This transitional shock could reflect in a specific social context, such as making a switch between professional roles (Schumacher & Meleis, 1994). Therefore, nursing managers should take some measurements to strengthen the new nurses' professional identity, to reduce their transition shock. For example, nursing managers could conduct some amusement or training courses related to humanistic care or the importance of nursing through the narration of meaningful stories.

Clinical teaching behaviour was negatively related to transition shock, which catered to the previous research findings. For example, one study has shown that nurse preceptors were vital in helping new nurses transit effectively into nursing practice (Powers et al., 2019). Especially, preceptors were called "a significant resource" to new nurses who valued their knowledge and teaching, and their guidance and support (Innes & Calleja, 2018). Therefore, it is the primary duty of the preceptors to ensure that patient safety was given a priority while the new nurses gained knowledge and practical experience. In order to help new nurses go through the transition phase successfully, preceptors helped new nurses to implement psychological skills that they may have learned but hardly used in the academy. They encourage them to use the equipment and documentation systems that they were unfamiliar with and get socialized to suit the culture of the departments' healthcare team. Therefore, an essential part of the clinical behaviour of preceptors was to diminish the transition shock of the new nurses and use various teaching strategies to build confidence in them to perform various nursing operations (Innes & Calleja, 2018). In addition to this, it is very important to narrow down the gap between the academy and the hospital to decrease the transition shock in all nursing settings. So, the nursing managers and administrators could work for providing nursing residency for new nurses, to have continued opportunities to apply their knowledge to nursing programmes and receive further nursing practice experience.

## 6.5 | Moderating effects of clinical teaching behaviour on professional identity and transition shock

This study ascertained the direct effect relationship between clinical teaching behaviour and transition shock and verified the moderating effects of clinical teaching behaviour on the relationship between professional identity and transition shock. That is to say,

the relationship between professional identity and transition shock was strengthened due to clinical teaching behaviour. It might be that the new nurses, that get better clinical teaching, show a better capacity to deal with transition shock. The nurses having low professional identity were guided by preceptors, who had good clinical teaching behaviour, helped them to improve the levels of their knowledge and built their confidence. They overall helped them in making nursing operations successful and groomed them to suit the departments' situation and culture thus increasing their sense of professional identity and decrease their transition shock.

## 6.6 | Limitations

Firstly, the use of convenience sampling (from eight hospitals) may limit the generalization of these findings, and we also had a limited sample for Lanzhou city. It is suggested that our research group is ready to continue exploring and expanding the sample size. Secondly, the study is a cross-sectional study with no follow-up of patients at different time points in their graduate year. A longitudinal research method would be better suited for detecting changes in their transition. Finally, this is a self-administered questionnaire with no opportunity to follow up on ideas and clarify issues, as such, answers may not be reflective of the true thoughts of new nurses.

## 7 | CONCLUSION

The study concludes that professional identity has a direct negative correlation with transition shock among new nurses. And the results showed that clinical teaching behaviour moderated the relationship between professional identity and transition shock. We support the idea that the nursing leaders and nursing managers should pay more attention to transition shock among new nurses and help them by strengthening their professional identity through their clinical teaching behaviour. Consequently, the study can form evidence-based interventions for decreasing transition shock among new nurses. For instance, nursing managers and administrators should not only improve the sense of self-worth in new nurses and build their professional identity but also make concerned preceptors strengthen their clinical teaching behaviour so as to improve new nurses' professional knowledge, confidence and the ability of critical thinking, which will help them to go through the transition successfully.

## 7.1 | Relevance to clinical practice

The findings of the present study would interest the hospital managers to better train new nurses recruited in their hospitals.

Firstly, the highest dimension of each scales is evaluated

- The main reason for high transition shock is the effect on their physical aspect. It means that the nursing managers should balance

the life and work of new nurses so that they can be relieved of physical fatigue by introducing flexibility in their schedule shifts.

- Low professional identity weakens their sense of mastery, so nursing managers should strengthen the training of theoretical knowledge and operational skills of new nurses. This will help them master the skills proficiently, ultimately enhancing their sense of professional identity.
- A good atmosphere is very important for new nurses to improve their clinical teaching behaviour. This requires nursing managers to select nurses with high emotional intelligence as head nurses to promote a good work atmosphere in the department.
- Besides, nursing managers can invite experienced nurses to talk about their knowledge of nursing and share kind stories of patients they took care of and other emotional experiences they encountered during work, which would enable new nurses to have a deeper understanding of their roles.

Most importantly, our study highlights the importance of clinical teaching behaviour in moderating the relationship between professional identity and transition shock. We report that the impact of professional identity and transition shock can be gradually alleviated by improving the workability of new nurses through clinical nursing teaching that is the clinical teaching behaviour of teachers and students. Hence, the nursing managers should take adequate measures such as strict teaching by preceptors by using a multi-method teaching approach, competitive qualifications among nurses, mutual support and feedback, etc. to improve clinical teaching behaviours in the hospital setting. This ultimately alleviates the strong impact of transition shock and low professional identity in new nurses thus creating a physically and mentally strong and competent professional nursing asset for the hospital and a truly supportive environment for the patients.

#### ACKNOWLEDGEMENT

The authors would like to thank eight hospitals for their cooperation, and 800 new nurses for their participation. Finally, authors thanked every student in our research group for their help.

#### CONFLICTS OF INTEREST

The authors declare no conflicts of interest.

#### AUTHOR CONTRIBUTIONS

Lin Han: Study design. Qian Su and Bei Yun: Data collection and analysis and manuscript drafting. Loretta Yuet Foon CHUNG, Lian Chen, Yamei Zuo and Jia Liu: Revision of the manuscript for important intellectual content.

#### DATA AVAILABILITY STATEMENT

The raw data set used to support the findings of the present study is available from the corresponding author upon request.

#### ORCID

Qian Su  <https://orcid.org/0000-0001-5749-4636>

Lin Han  <https://orcid.org/0000-0001-7821-5253>

#### REFERENCE

- Acuna, G. K., Yoder, L. H., Madrigal-Gonzalez, L., & Yoder-Wise, P. S. (2017). Enhancing transition to practice using a valid and reliable evaluation tool: Progressive orientation level evaluation (POLE) tool. *Journal of Continuing Education in Nursing*, 48, 123–128. <https://doi.org/10.3928/00220124-20170220-08>
- Ahlstedt, C., Eriksson Lindvall, C., Holmström, I. K., & Muntlin Athlin, Å. (2019). What makes registered nurses remain in work? An ethnographic study. *International Journal of Nursing Studies*, 89, 32–38. <https://doi.org/10.1016/j.ijnurstu.2018.09.008>
- Barnes, H. (2015a). Exploring the factors that influence nurse practitioner role transition. *The Journal for Nurse Practitioners*, 11, 178–183. <https://doi.org/10.1016/j.nurpra.2014.11.004>
- Barnes, H. (2015b). Nurse practitioner role transition: A concept analysis. *Nursing Forum*, 50, 137–146. <https://doi.org/10.1111/nuf.12078>
- Beecroft, P. C., Kunzman, L., & Krozek, C. (2001). RN internship: Outcomes of a one-year pilot program. *The Journal of Nursing Administration*, 31, 575–582. <https://doi.org/10.1097/00005110-200112000-00008>
- Chen, J., Davis, K. G., Daraiseh, N. M., Pan, W., & Davis, L. S. (2014). Fatigue and recovery in 12-hour dayshift hospital nurses. *Journal of Nursing Management*, 22, 593–603. <https://doi.org/10.1111/jonm.12062>
- Cline, D., La Frenz, K., Fellman, B., Summers, B., & Brassil, K. (2017). Longitudinal outcomes of an institutionally developed nurse residency program. *Journal of Nursing Administration*, 47, 384–390. <https://doi.org/10.1097/NNA.0000000000000500>
- Clipper, B., & Cherry, B. (2015). From transition shock to competent practice: Developing preceptors to support new nurse transition. *The Journal of Continuing Education in Nursing*, 46, 448–454. <https://doi.org/10.3928/00220124-20150918-02>
- Crisp, N., & Iro, E. (2018). Nursing Now campaign: Raising the status of nurses. *Lancet (London, England)*, 391, 920–921. [https://doi.org/10.1016/s0140-6736\(18\)30494-x](https://doi.org/10.1016/s0140-6736(18)30494-x)
- Cusson, R. M., & Strange, S. N. (2008). Neonatal nurse practitioner role transition: The process of reattaining expert status. *The Journal of Perinatal & Neonatal Nursing*, 22, 329–337. <https://doi.org/10.1097/01.Jpn.0000341365.60693.39>
- de Cordova, P. B., Bradford, M. A., & Stone, P. W. (2016). Increased errors and decreased performance at night: A systematic review of the evidence concerning shift work and quality. *Work*, 53, 825–834. <https://doi.org/10.3233/WOR-162250>
- Deng F. L., Luo N., Cao M. E., Zhao H., (2013). Survey of status quo of vocational identity of nurses in three grade hospitals in a city. *Chinese Nursing Research*, 27(9). <https://doi.org/10.3969/j.issn.1009-6493.2013.09.014>
- Duchscher, J. B. (2008). A Process of Becoming: The Stages of New Nursing Graduate Professional Role Transition. *The Journal of Continuing Education in Nursing*, 39(10), 441–450. <https://doi.org/10.3928/00220124-20081001-03>
- Duchscher, J. E. (2009). Transition shock: The initial stage of role adaptation for newly graduated registered nurses. *Journal of Advanced Nursing*, 65, 1103–1113. <https://doi.org/10.1111/j.1365-2648.2008.04898.x>
- Fu, C.-Y., Yang, M.-S., Leung, W., Liu, Y.-Y., Huang, H.-W., & Wang, R.-H. (2018). Associations of professional quality of life and social support with health in clinical nurses. *Journal of Nursing Management*, 26, 172–179. <https://doi.org/10.1111/jonm.12530>
- Haggerty, C., Holloway, K., & Wilson, D. (2013). How to grow our own: An evaluation of preceptorship in New Zealand graduate nurse programmes. *Contemporary Nurse*, 43, 162–171. <https://doi.org/10.5172/conu.2013.43.2.162>
- Hirschi, A. (2012). Callings and work engagement: Moderated mediation model of work meaningfulness, occupational identity, and occupational self-efficacy. *Journal of Counseling Psychology*, 59, 479–485. <https://doi.org/10.1037/a0028949>
- Ho, W.-H., Chang, C. S., Shih, Y.-L., & Liang, R.-D. (2009). Effects of job rotation and role stress among nurses on job satisfaction and

- organizational commitment. *BMC Health Services Research*, 9, 8. <https://doi.org/10.1186/1472-6963-9-8>
- Innes, T., & Calleja, P. (2018). Transition support for new graduate and novice nurses in critical care settings: An integrative review of the literature. *Nurse Education in Practice*, 30, 62–72.
- Johnson, M., Cowin, L. S., Wilson, I., & Young, H. (2012). Professional identity and nursing: Contemporary theoretical developments and future research challenges. *International Nursing Review*, 59, 562–569. <https://doi.org/10.1111/j.1466-7657.2012.01013.x>
- Kelly, J., & McAllister, M. (2013). Lessons students and new graduates could teach: A phenomenological study that reveals insights on the essence of building a supportive learning culture through preceptorship. *Contemporary Nurse*, 44, 170–177. <https://doi.org/10.5172/conu.2013.44.2.170>
- Kramer, M., Brewer, B. B., & Maguire, P. (2013). Impact of healthy work environments on new graduate nurses' environmental reality shock. *Western Journal of Nursing Research*, 35, 348–383. <https://doi.org/10.1177/0193945911403939>
- Kumaran, S., & Carney, M. (2014). Role transition from student nurse to staff nurse: Facilitating the transition period. *Nurse Education in Practice*, 14, 605–611. <https://doi.org/10.1016/j.nepr.2014.06.002>
- Kwak, Y., Kim, J.-S., Han, Y., & Seo, Y. (2018). The Effect of work addiction on Korean nurses' professional quality of life: A cross-sectional study. *Journal of Addictions Nursing*, 29, 119–127. <https://doi.org/10.1097/JAN.0000000000000221>
- Lee-Hsieh, J., O'Brien, A., Liu, C.-Y., Cheng, S.-F., Lee, Y.-W., & Kao, Y.-H. (2016). The development and validation of the Clinical Teaching Behavior Inventory (CTBI-23): Nurse preceptors' and new graduate nurses' perceptions of precepting. *Nurse Education Today*, 38, 107–114. <https://doi.org/10.1016/j.nedt.2015.12.005>
- Martin, K. (2011). Newly registered nurses' experience in the first year of practice: A phenomenological study. *International Journal of Human Caring*, 15(2), 21–27. <https://doi.org/10.20467/1091-5710.15.2.21>
- McCalla-Graham, J. A., & De Gagne, J. C. (2015). The lived experience of new graduate nurses working in an acute care setting. *Journal of Continuing Education in Nursing*, 46, 122–128. <https://doi.org/10.3928/00220124-20150220-17>
- Moore, M., & Hofman, J. E. J. H. E. (1988). Professional identity in institutions of higher learning in Israel. *Higher Education*, 17, 69–79. <https://doi.org/10.1007/bf00130900>
- Nowrouzi, B., Giddens, E., Gohar, B., Schoenenberger, S., Bautista, M. C., & Casole, J. (2016). The quality of work life of registered nurses in Canada and the United States: A comprehensive literature review. *International Journal of Occupational and Environmental Health*, 22, 341–358. <https://doi.org/10.1080/10773525.2016.1241920>
- Polit, D. F., Beck, C. T., & Owen, S. V. (2007). Is the CVI an acceptable indicator of content validity? Appraisal and recommendations. *Research in Nursing & Health*, 30, 459–467. <https://doi.org/10.1002/nur.20199>
- Poronsky, C. B. (2012). A literature review of mentoring for RN-to-FNP transition. *The Journal of Nursing Education*, 51, 623–631. <https://doi.org/10.3928/01484834-20120914-03>
- Powers, K., Herron, E. K., & Pagel, J. (2019). Nurse preceptor role in new graduate nurses' transition to practice. *Dimensions of Critical Care Nursing*, 38, 131–136. <https://doi.org/10.1097/DCC.0000000000000354>
- Sabanciogullari, S., & Dogan, S. (2015). Effects of the professional identity development programme on the professional identity, job satisfaction and burnout levels of nurses: A pilot study. *International Journal of Nursing Practice*, 21, 847–857. <https://doi.org/10.1111/ijn.12330>
- Schumacher, K. L., & Meleis, A. I. (1994). Transitions: A central concept in nursing. *Image: the Journal of Nursing Scholarship*, 26, 119–127. <https://doi.org/10.1111/j.1547-5069.1994.tb00929.x>
- Suzuki, E., Itomine, I., Kanoya, Y., Katsuki, T., Horii, S., & Sato, C. (2006). Factors affecting rapid turnover of novice nurses in university hospitals. *Journal of Occupational Health*, 48, 49–61. <https://doi.org/10.1539/joh.48.49>
- Trede, F., Macklin, R., & Bridges, D. (2012). Professional identity development: A review of the higher education literature. *Studies in Higher Education*, 37, 365–384. <https://doi.org/10.1080/03075079.2010.521237>
- Wang, X. Q., & Chen, P. J. (2014). Population ageing challenges health care in China. *Lancet (London, England)*, 383, 870. [https://doi.org/10.1016/s0140-6736\(14\)60443-8](https://doi.org/10.1016/s0140-6736(14)60443-8)
- Ward, A., & McComb, S. (2017). Precepting: A literature review. *Journal of Professional Nursing*, 33, 314–325. <https://doi.org/10.1016/j.profnurs.2017.07.007>
- Weng, R.-H., Huang, C.-Y., Tsai, W.-C., Chang, L.-Y., Lin, S.-E., & Lee, M.-Y. (2010). Exploring the impact of mentoring functions on job satisfaction and organizational commitment of new staff nurses. *BMC Health Services Research*, 10, 240. <https://doi.org/10.1186/1472-6963-10-240>
- Xue, Y. R., Lin, P., Gao, X. Q., Zhao, Z. J., Li, L., Liu, G. J., & Yang, S. F. (2015a). Development and the reliability and validity test of the Transition Shock of Newly Graduated Nurses Scale. *Chinese Journal of Nursing*, 50(6), 674–678. <https://doi.org/10.3761/j.issn.0254-1769.2015.06.007>
- Xue, Y. R., Lin, P., Liu, D., Wang, Y. N., Zhang, G., Liu, L. (2015b). Investigation and analysis on the transition shock of newly graduated nurses in class-three hospitals. *Chinese Journal of Modern Nursing*, 21(9). <https://doi.org/10.3760/CMA.J.ISSN.1674-2907.2015.09.001>
- Zeng, H. J., Zhou, G. Y., Yan, H. H., Yang, X. H., & Jin, H. M. (2018). Chinese nurses are at high risk for suicide: A review of nurses suicide in China 2007–2016. *Archives of Psychiatric Nursing*, 32, 896–900. <https://doi.org/10.1016/j.apnu.2018.07.005>
- Zhao, H., Lu, T. T., Zhang, C. Y., Deng, F. L., Zhen, J. P., Da, X. M. F., Yong, T. W. Z., Xiao, L. X. H., & Jian, T. S. Y. (2010). Testing for reliability and validity of Chinese version of the Nurse's Career Identity Scale. *Chinese Nursing Management*, 2010, 49–51.

**How to cite this article:** Su Q, YUN B, Yuet Foon Chung L, et al. Clinical teaching behaviour effects professional identity and transition shock in new nurses in western china: A cross-sectional study. *Nurs Open*. 2021;8:2605–2615. <https://doi.org/10.1002/nop2.798>