

Glycine gated spiking inhibitory postsynaptic membrane at the synaptic cleft

Krishna M Deka, Soumik Roy

Department of Electronics and Communication Engineering, Tezpur University, Napaam Post, Tezpur, Assam -784028

KEY WORDS

Neuron
Synapse
ENFET
Postsynaptic membrane
Membrane potential
Glycine

ABSTRACT

Background: Enzyme modified field effect transistor (ENFET) may be used to represent the variable conductance of transmitter-gated ion channels in the postsynaptic region of the neuron. **Purpose:** The objective of this work is to develop a simple analog circuit model that can simulate the function of neurotransmitter glycine gated ion channels of postsynaptic membrane at the synaptic cleft. **Methods:** In this paper, Glycine sensitive ENFET is incorporated into the Hodgkin-Huxley (H-H) circuit model of the postsynaptic membrane at the synaptic cleft. **Results:** Simulation of the circuit model yields an output representing the membrane potential of the synaptic region. Simulation is performed in MATLAB environment for inhibitory action of synapses. **Conclusion:** This model can be used in neuro-bioengineering fields for simulation of binding activity and electrical activity of the postsynaptic region.

Corresponding Author:

Krishna M Deka
Tel : 09864805324
E-mail : krishadk6@gmail.com

doi : 10.5214/ans.0972.7531.210404

Introduction

Biologically inspired neuron models are a kind of neuromorphic devices that is an electrical equivalent circuit which is designed to reproduce various phenomena in biological neurons. Biologically inspired neuron models are developed considering electrophysiological behaviour of real neuron. Among the different biologically inspired neuron models, neuron models with enzyme modified field effect transistor (ENFET) are most popular. Studies of biological model involving *in vivo* and *in vitro* models for various degenerative diseases such as Age-related macular degeneration (AMD), Alzheimer's disease (AD), stroke¹⁻⁶ using wider sample size, involving different parameters could be utilised in simulating the models based on sensor and emitter technology.

2-aminoethanoic acid (Glycine) is an organic compound with the formula $\text{NH}_2\text{CH}_2\text{COOH}$,⁷ having a hydrogen substituent as its side chain. Glycine is the smallest of the 20 amino acids commonly found in proteins, responsible for synaptic inhibition in the central nervous system especially in the spinal cord, brainstem and retina.⁸ Most of the studies, related to iontophoretic application of Glycine in the Central Nervous System (CNS) indicates that it produces inhibitory hyperpolarizing responses in neurons. The hyperpolarizing response occurs due to an increase in the chloride conductance of the neuronal membrane allowing chloride ions to flow down their electrochemical gradient into the cell. The membrane of post synaptic neuron has two types of ion channels-excitatory and inhibitory. The excitatory channels are those which are specific to sodium ions and inhibitory channels are those which are specific to chloride ions. The flow of sodium ions into the cell causes a membrane potential called excitatory postsynaptic membrane potential (EPSP) whereas the flow of chloride ions causes an inhibitory postsynaptic membrane potential (IPSP).

The electrical mechanism of synapse is shown in Figure 1. If the synapse is excitatory, Sodium ions flow into the cell resulting into positive current. As a result the membrane depolarizes. If sufficient number of Sodium channels open, then membrane po-

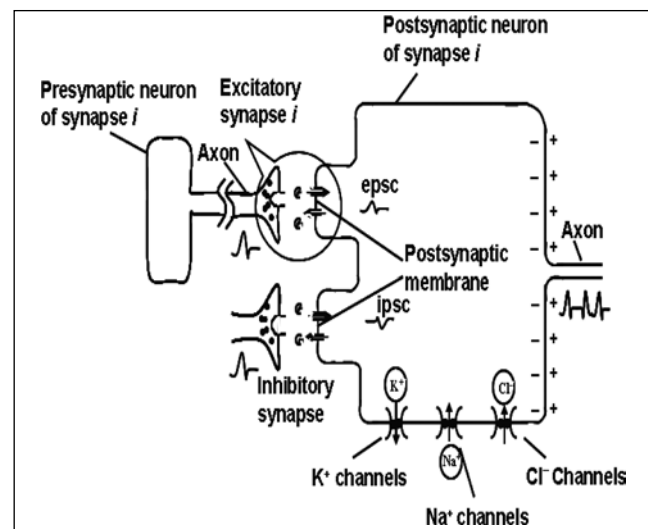

Fig. 1: Electrical mechanism of synapse.

tential will be greater than the threshold potential V_T of the neuron and initiates an action potential. If the synapse is inhibitory, chloride ions move into the cell, resulting into negative current. As a result the membrane hyperpolarizes. If the numbers of opening of Chloride channels are sufficiently large then membrane potential will be able to initiate an action potential in negative direction. Figure 2 shows the equivalent circuit of a synapse which is developed by adding Hodgkin-Huxley (H-H) equivalent circuit with the presynaptic circuit, where I is the total current from ionic channels of all synapses and E_1, E_2, \dots, E_M represent the chemical potentials of each corresponding ions. For example, E_M may be E_{Na} or may be E_{Cl} . The total current I will stimulate the postsynaptic neuron to initiate an action potential.⁹⁻¹²

The total membrane current is divided into two components: a capacitive current and an ionic current. Thus total membrane currents:

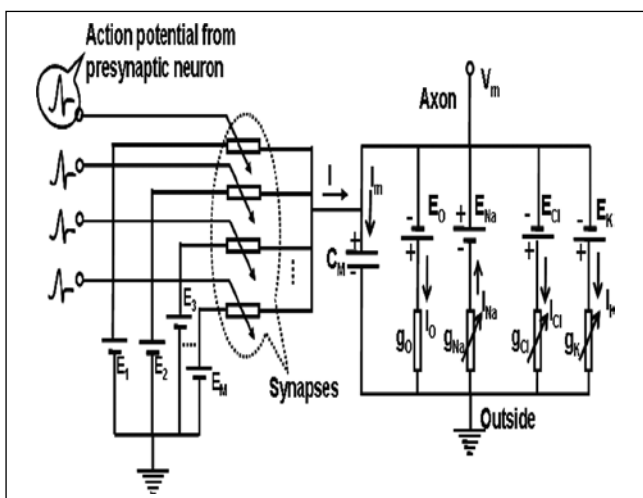

Fig. 2: Electrical equivalent circuit of synapse.

$$I = I_C + I_{ion}$$

$$I = I_m + I_o - I_{Na} + I_K$$

$$= C_M (dV_m/dt) + g_o(V_m - E_o) - g_{Na}(V_m - E_{Na}) + g_K(V_m - E_K)$$

where V_m represents the postsynaptic membrane potential established by the ionic and capacitive membrane current, C_M is the capacitance of the lipid bilayer of postsynaptic membrane, t is time.

Modeling theory of Glycine gated ion channels

In case of inhibitory action, Glycine is released by the presynaptic terminals into the synaptic cleft. Glycine diffuses through the cleft and bind with specific receptor sites of post synaptic membrane. In simplest case, the binding reaction may be represented as:¹³

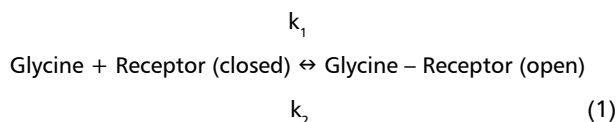

where k_1 and k_2 are the forward and backward rate constants respectively. The field effect transistor (FET) gate surface plays an important role in the sensitivity and stability of the sensor. Each surface layer possesses certain pH sensitivity and can, therefore, detect minute changes in pH close to the electrolyte/insulator interface.

The glycine sensitive ENFET is prepared by immobilizing serine hydroxymethyl transferase on the surface of gate oxide (Ta_2O_5/Al_2O_3) (Fig. 3).

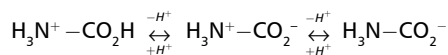

In aqueous solution glycine itself is amphoteric: at low pH the molecule can be protonated with a pK_a of about 9.6 and at high pH it loses a proton with a pK_a of about 2.4 (precise values of pK_a depend on temperature and ionic strength). The nature of glycine in aqueous solution has been investigated by theoretical methods.¹⁴ In solution the ratio of concentrations of the two isomers is independent of both the analytical concentration

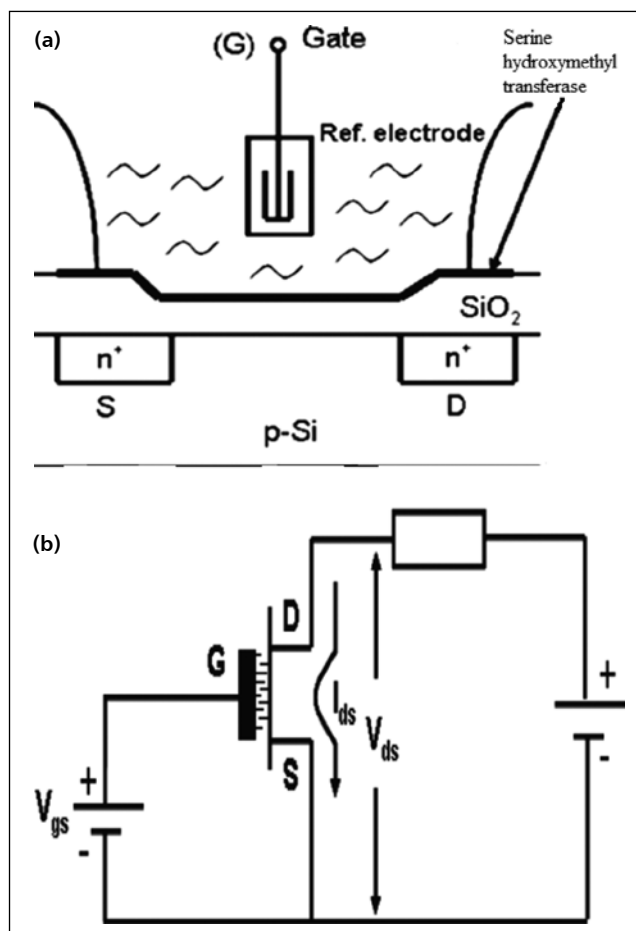
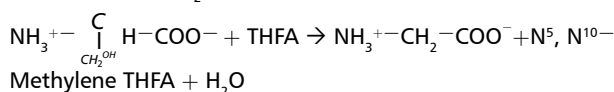
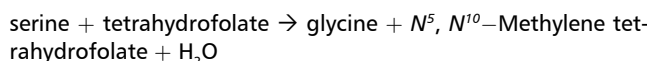

Fig. 3: Glycine ENFET (a) Schematic diagram (b) Electronic diagram.

and of pH. This ratio is simply the equilibrium constant for isomerization. Glycine is not essential to the human diet, as it is biosynthesized in the body from the amino acid serine, which is in turn derived from 3-phosphoglycerate. In most organisms, the enzyme Serine hydroxymethyl transferase catalyses this transformation via the cofactor pyridoxal phosphate:¹⁵



The proton generated in this reaction changes the pH inside the enzyme which is registered by the underlying ion sensitive FET. The threshold voltage of such device, $V_{TH}(IS)$, is a function of pH of solution dependent on the concentration of glycine. For very small value of drain to source voltage of ENFET, V_{ds} , the conductance of such ENFET can be expressed as:¹⁶

$$G_{ds} = \beta(V_{gs} - V_{TH}(IS)) \quad (2)$$

β is the geometric sensitivity parameter given by

$$\beta = \mu C_{ox} (W/L)$$

where C_{ox} is the oxide capacity per unit area, W and L are the width and the length of the channel respectively, and μ is the

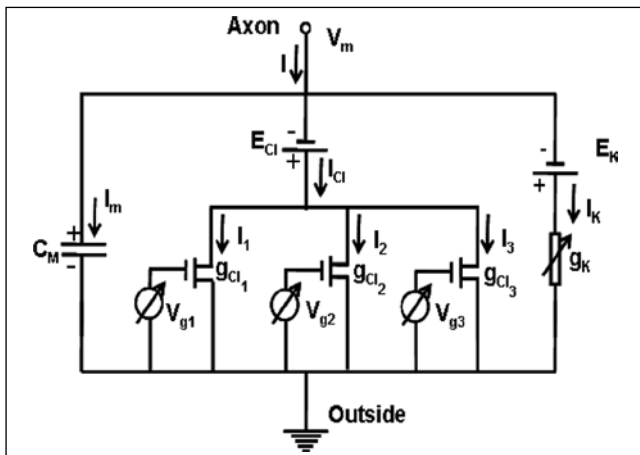

Fig. 4: Circuit model for Postsynaptic membrane.

electron mobility in the channel. V_{gs} is the voltage applied to the reference electrode and $V_{TH}(IS)$ is the threshold voltage of the ENFET. In ENFET, β and V_{gs} are constants and $V_{TH}(IS)$ is the only input variable. Thus G_{ds} is dependent on the threshold voltage, $V_{TH}(IS)$, analogous to the conductance of ion channels of postsynaptic membrane dependent on the binding activity. The neurotransmitter gated ion channels can therefore be represented by glycine sensitive ENFET due to its variable nature of conductance with respect to voltage. Glycine receptor binding activity is a time dependent phenomenon and therefore number of opening of transmitter gated ion channels will be varying with respect to time. $V_{TH}(IS)$ in equation (2) can, therefore, be modeled as:¹⁷

$$V_{TH}(IS)(t) = V_{THO} [1 - \exp(-k_1 t) + \exp(-k_2 t)U(t - t_m)] \quad (3)$$

where k_1 and k_2 are time constants analogous to the rate constants of equation (1), $U(t - t_m)$ is the Heaviside function and V_{THO} is the threshold voltage proportional to the maximum attainable conductance, when all the transmitter-gated channels for Cl^- ions are open.

Modeling neuron for inhibitory synapse

The modeling for inhibitory synapse is shown in Figure 4. Considering only Cl^- channels to be responsible for inhibitory action, the post synaptic membrane is divided into three patches to represent spatial summation of the Chloride current controlled by

$$I_{Cl} = I_1 + I_2 + I_3$$

$$I = I_m + I_o - I_{Cl} + I_k$$

$$I = C(dV_m/dt) + g_{Cl}(V_m - E_{Cl}) + g_K(V_m - E_K)$$

where g_{Cl} is the total Chloride conductance and g_K is the non-gated potassium conductance. V_{g1} , V_{g2} and V_{g3} are the voltages applied to the reference electrodes of the ENFETs. The membrane potential V_m is obtained by spatially and temporally varying g_{Cl} of Glycine-gated Chloride channels.

A spiking model is a mathematical model which describes how input spike trains (sequences of timings) are mapped to an

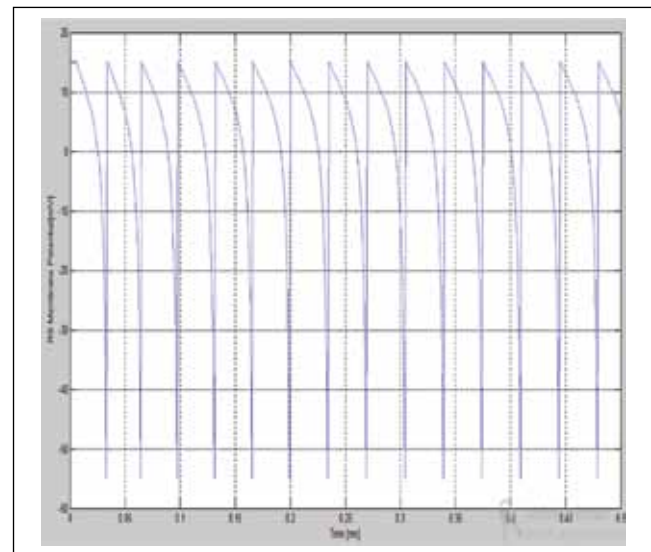

Fig. 5: Simulated result of postsynaptic membrane potential.

output spike train. Thus the output can be characterized by

$$S = (t_i; i = 1, 2, \dots, n), t_i < t_{i+1}$$

Where t_i is the i^{th} spike train in a train of n spikes.¹⁸ The spiking strategy that is used in Glycine gated postsynaptic membrane is by integrating the differential equation for membrane potential with Euler approximation method and then thresholding the output.

Simulation

The component values assigned in the model for MATLAB simulation are:¹⁹ $C_m = 1 \mu\text{F per cm}^2$, $g_K = 1 \text{ mS per cm}^2$, $E_{Cl} = -100 \text{ mV}$ and $E_K = -90 \text{ mV}$. The specifications for three p-channel MOSFETS are $L = 15 \mu\text{m}$, $W = 2 \mu\text{m}$, $t_{ox} = 100 \text{ nm}$, $\mu = 600 \text{ cm}^2/\text{V-sec}$. The parameters for exponential function in equation (3), applied to each MOSFET inputs are: $V_o = -5 \text{ Volts}$, $t_m = 850 \mu\text{sec}$, $K_1 = K_2 = 0.8 \text{ msec}$.

Results

The MATLAB simulation outputs are shown below (Fig. 5). The waveform represents the normal postsynaptic membrane potential with respect to time. V_m is established by spatial summation and temporal integration of the glycine-gated current. In this model, action potential is inhibited whenever the membrane potential is depolarized to a value 65 mV and after that the action potential is reset to a value of -35 mV; The action potential thus takes the form of spikes and occurs during the time period of the pulse.

Conclusions

Thus glycine-sensitive ENFET can be used as circuit analog to simulate the inhibitory postsynaptic membrane potential. Both in neurology and bioelectronics area this biologically motivated model may become a useful tool for research and teaching unit. This approach of the model can be used for various other types of neurotransmitter-gated channels to reproduce a wide variety of electrical responses.

Acknowledgements

The authors wish to thank UGC and AICTE for their support to Bioelectronics programme and Neurobioengineering research.

This article complies with International Committee of Medical Journal Editor's uniform requirements for manuscript.

Conflict of interest: None.

Competing interests: None, Source of funding: UGC, AICTE.

Received Date : 18 May 2014; Revised Date : 25 July 2014;

Accepted Date : 12 August 2014

References

- Sharma NK, Gupta A, Prabhakar S, et al. CC Chemokine receptor-3 as new target for age related macular degeneration. *Gene*. 523 (2013); 106–111.
- Anand A, Sharma NK, Prabhakar S, et al. Single Nucleotide Polymorphisms in MCP-1 and its Receptor are associated with the risk of Age Related Macular Degeneration. *PLoS ONE*. 2012; 7(11).
- Sharma NK, Gupta A, Prabhakar S, Singh R, Sharma S, Anand A Single nucleotied polymorphism and serum levels of VEGFR2 are associated with age related macular degeneration. *Curr Neurovasc Res*. 2012; 9(4): 256–65.
- Prabhakar S, Saraf M, Promila P, et al. Bacopa monniera exerts anti-amnesic effect on diazepam-induced anterograde amnesia in mice. *Psychopharmacology*. 2008; 200(1): 27–37.
- Anand A, Saraf MK, Prabhakar S. Sustained inhibition of brotizolam induced anterograde amnesia by norharmane and retrograde amnesia by l-glutamic acid in mice. *Behavioural Brain Research*. 182; 1: 12–20.
- Saraf MK, Prabhakar S, Krishan LK, et al. Bacopa monniera Attenuates Scopolamine-Induced Impairment of Spatial Memory in Mice. Evidence based complimentary and alternative medicine. 2011; 2011: 1–10.
- Nomenclature and symbolism for amino acids and peptides(IUPAC-IUB Recommendations 1983), *Pure Appl. Chem*. 56 (5), 1984: 595–624.
- Plimmer RHA (1912) [1908]. Plimmer RHA & Hopkins FG, ed. The chemical composition of the proteins. Monographs on biochemistry. Part I. Analysis (2nd ed.). London: Longmans, Green and Co. p. 82. Retrieved January 18, 2010.
- Zhang AL. A Mathematical Model of a neuron with Synapses based on Physiology; *Nature Proceedings*, npre. 2008.1703.1 March 2008.
- Roy S, Dutta JC, Phukan S. Integrate-and- Fire based Circuit model for simulation of excitatory and Inhibitory synapses; *Canadian Journal on Biomedical Engineering & Technology* Vol.1, No. 2 March 2010; 49–51.
- Deka K, Roy S. Biologically Inspired Circuit Model for Simulation of Glutamate Gated Ion Channels of the Postsynaptic Membrane at Synaptic Cleft. *Annals of Neuroscience*. 2013; 20(4): 145–148.
- Deka K, Roy S. Glutamate Gated Spiking Neuron Model. *Annals of Neurosciences*. 2014; 21(1): 14–18.
- Michael DL, Fare TL. A Physiologic-Based Circuit Model of the Postsynaptic region at the Neuromuscular Junction. *IEEE Proceedings*, pp. 1602–1603, ISBN: 0–7803–0785–2.
- Bonaccorsi R, Palla P, Tomasi J. Conformational energy of glycine in aqueous solutions and relative stability of the zwitterionic and neutral forms. An ab initio study. *J. Amer. Chem. Soc*. 1984; 106 (7): 1945–1950.
- Nelson, David L., Cox, Michael M. (2005), *Principles of Biochemistry* (4th ed.), New York: W. H. Freeman, pp. 127, 675–77, 844, 854, ISBN 0–7167–4339–6.
- B. Streetman. *Solid State Electronics Devices*. 2nd Ed., pp.311–313,1980.
- Michael DL, Fare TL. A Physiologic- Based Circuit Model of Excitation & Inhibition in the Postsynaptic region. *IEEE Proceedings of the 35th Midwest symposium on Circuits & Systems.*, pp. 268–269, Vol-I, ISBN: 0–7803–0510–8.
- Smith L. *Implementing Neural Models in Silicon Handbook of Nature-Inspired and Innovative Computing* Section 11, Springer, 2006.
- Bergveld P. Thirty years of ISFETOLOGY what happened in the Past 30 years and what may happen in the next 30 year; *Sensors and Actuators B*. 2003; 88: 1–20.