



Special issue in honor of Prof. George C. Papageorgiou

REVIEW

Photosystem II in bio-photovoltaic devices

R.A. VOLOSHIN*, S.M. SHUMILOVA*, E.V. ZADNEPROVSKAYA*, S.K. ZHARMUKHAMEDOV**, S. ALWASEL***, H.J.M. HOU#, and S.I. ALLAKHVERDIEV*.,**.,***.,+.

*Controlled Photobiosynthesis Laboratory, K.A. Timiryazev Institute of Plant Physiology, Russian Academy of Sciences, 127276 Moscow, Russia**

*Institute of Basic Biological Problems, RAS, Pushchino, 142290 Moscow Region, Russia***

*College of Science, King Saud University, Riyadh, Saudi Arabia****

Laboratory of Forensic Analysis and Photosynthesis, Department of Physical/Forensic Sciences, Alabama State University, Montgomery, 36104 Alabama, United States#

Abstract

Hybrid photoelectrodes containing biological pigment–protein complexes can be used for environmentally friendly solar energy conversion, herbicide detection, and other applications. The total number of scientific publications on hybrid bio-based devices has grown rapidly over the past decades. Particular attention is paid to the integration of the complexes of PSII into photoelectrochemical devices. A notable feature of these complexes from a practical point of view is their ability to obtain electrons from abundant water. The utilization or imitation of the PSII functionality seems promising for all of the following: generating photoelectricity, photo-producing hydrogen, and detecting herbicides. This review summarizes recent advances in the development of hybrid devices based on PSII. In a brief historical review, we also highlighted the use of quinone-type bacterial reaction centers in hybrid devices. These proteins are the first from which the photoelectricity signal was detected. The photocurrent in these first systems, developed in the 70s–80s, was about 1 nA cm⁻². In the latest work, by Güzel *et al.* (2020), a stable current of about 888 µA cm⁻² as achieved in a PSII-based solar cell. The present review is inspired by this impressive progress. The advantages, disadvantages, and future endeavors of PSII-inspired bio-photovoltaic devices are also presented.

Keywords: electron transfer; photoanode; photo-bioelectrochemical cell; photocurrent.

Highlights

- Reaction centers are promising for solar energy conversion
- Many types of photo-bioelectrochemical cells have been described in the literature
- The mesostructure of the electrode plays a key role in photocurrent generation

Received 30 May 2021

Accepted 18 February 2022

Published online 7 March 2022

*Corresponding author

e-mail: suleyman.allakhverdiev@gmail.com

Abbreviations: ACVD – aerosol-controlled vapor deposition; bRC – bacterial reaction center; BSA – bovine serum albumin; DCBQ – 2,6-dichloro-1,4-benzoquinone; DET – direct electron transfer; EQE – external quantum efficiency; FF – fill factor; FTO – fluorine-doped tin oxide; Histag – six histidine residues motif; IO – inverse opal; IO-mesoITO – hierarchically structured inverse opal mesoporous indium tin oxide; IQE – internal quantum efficiency; I_{sc} – short-circuit current; ITO – indium tin oxide; MET – mediated electron transfer; MF – Millipore membrane filter; Ni-NTA – Ni(II)-nitrilotriacetic acid; OEC – oxygen-evolving complex; P₆₈₀ – PSII special pair; PBEC – photo-bioelectrochemical cell; PEM – proton exchange membrane; Pheo – pheophytin; PVC – polyvinyl chloride; Q_BH₂ – plastoquinol Q_B; RC – reaction center; SAM – self-assembling monolayer; SSA – specific surface area; V_{oc} – open-circuit voltage.

Acknowledgments: We are grateful to Dr. Douglas Strout for his critical reading of the manuscript and for his constructive comments to improve the quality of the manuscript. SMS, RAV, SKZ, and SIA were supported by a grant from the Russian Science Foundation (No. 19-14-00118). Figs. 5 and 6 were supported by the grant of state assignment of Ministry of Science and Higher Education of the Russian Federation (No. 121033000136-4). SA would like to thank the Distinguished Scientists Fellowship Program, King Saud University, Saudi Arabia, for the support.

Conflict of interest: The authors declare that they have no conflict of interest.

Introduction

The exponentially growing scientific interest in the practical application of primary photosynthetic processes is stimulated, on the one hand, by progress in understanding the mechanisms underlying photosynthesis, and on the other hand, by the problems faced by humanity. Let us briefly note the challenges for the meeting of which hybrid bio-based photovoltaic devices can be used.

Energy depletion and environmental degradation appear to be the most serious problems. The increase of the world's population leads to a rapid growth in energy demand, which is largely met by nonrenewable fossil fuels (Weijermars *et al.* 2012, IEA 2019). The problem of fossil fuel depletion and the deleterious effects of its use on the environment has long been discussed (Allen 1977, Kumar and Kuppam 2020). The consumption of such energy sources can be minimized by using alternative, environmentally friendly energy resources (Voloshin *et al.* 2015, Rodionova *et al.* 2017).

The Sun is the most promising energy source. It is providing more energy for the Earth in one hour than it is consumed by people in a year (Lewis and Nocera 2006). However, common semiconductor solar cells or solar cells based on artificial sensitizers have some disadvantages, including high production costs and associated environmental problems (Grätzel 2001, 2007; Chen *et al.* 2012, Musazade *et al.* 2018).

One of the alternative directions of solar energy harvesting is the utilization or imitation of native photosynthetic structures and mechanisms. Integration of the PSII pigment–protein complex of the oxygenic phototrophic organisms is of particular interest due to the possibility to generate photoelectrons from water (Pandey *et al.* 2016).

Another problem associated with human activity is the contamination of soil, water, and air by toxic chemicals. Among the multiple pollutants, some hamper both humans and inhibit the photosynthetic activity of plants. They include herbicides and heavy metals. These compounds originate from industrial waste effluents and agricultural run-off. Chemicals with a slow degradation rate can be accumulated in soil and surface water in high enough amounts undermining the health of the ecosystem. In developed countries, prohibitions are introduced on the use of certain herbicides and maximum permissible concentrations of these compounds in the soil are established (Touloupakis *et al.* 2005). The threshold level for herbicides is very low. For example, within the European Union, it is $0.5 \mu\text{g L}^{-1}$ for total pesticides (Merz *et al.* 1996). The herbicide control requires a convenient and sensitive system for the assessment of water and soil quality. The standard chromatographic method of herbicide detection is very sensitive and selective, however, at the same time, it is very complicated and cumbersome (Koblížek *et al.* 2002). Standard algal growth test, also used for herbicide detection, is less sensitive and needs more time (Masojídek *et al.* 2011). When we have to deal with herbicide inhibiting the photosynthetic activity, it seems quite logical to use photosynthetic pigment–protein complexes as sensory elements.

The bio-based hybrid electrode is the basis for all of the aforementioned PSII applications. The transfer of electrons from a natural pigment–protein complex to an inorganic component of the electrical circuit is a mandatory step in the energy conversion and detection of herbicides. The high performance of the photoinduced electron transfer reaction in the hybrid electrodes is important for all PSII photo-bioelectrochemical applications.

Another application of bio-based photoelectrodes is the investigation of the fundamental photosynthetic processes. Although common principles of photosynthesis are well known, there are many unknowns about particular features of electron and energy transfer and photosynthetic regulation and acclimation. There are several commonly used techniques for measuring the activity of the primary photosynthetic processes. They include chlorophyll fluorimetry, polarography, and flash spectroscopy (Walker *et al.* 1983, Walker 1993, Wiederrecht *et al.* 1994, Kalaji *et al.* 2014). Analysis of photoelectrochemical processes in the PSII-based hybrid electrodes offers another tool for photosynthesis monitoring (Seibert *et al.* 1982, Kato *et al.* 2014).

Notwithstanding the many years of persistent efforts, the main disadvantage of bio-based hybrid devices has not been overcome. It is the low stability of the biomolecules (Allakhverdiev *et al.* 2010a,b). One solution to this obstacle is to develop a completely artificial system that has the advantages of natural systems and, at the same time, is devoid of their disadvantages.

In this paper, we review the current literature on photo-bioelectrochemical devices based on PSII. We will describe only two areas of the pigment–protein complexes application: solar energy conversion and herbicide detection. In addition, one can find other photosystem-based electrode applications in scientific literature, *e.g.*, memory devices and light sensors (Nishiori *et al.* 2019, Güzel *et al.* 2020). The first section is a brief description of the PSII structure and its utility for electrochemical applications. The second section describes the materials most often used in PSII-based hybrid electrodes and the features of attaching photosystems to conductive substrates. The third section presents the analysis of different types of solar cells based on PSII. In the fourth section, the features of hydrogen production due to the PSII-based half cell of water splitting are briefly outlined. The fifth section focuses on PSII-based herbicide detection systems. The sixth section is devoted to artificial systems that mimic the native PSII.

Photosystem II

The first photoelectrochemistry measurements of photosynthetic components have been done with reaction centers (RC) of the purple bacteria (bRC) (Drachev *et al.* 1975, Packham *et al.* 1980). The promise of RC is because the quantum yield of charge separation in the photosynthetic RC is close to 100% (Emerson *et al.* 1957). RC of PSII is similar to bRC (Michel and Deisenhofer 1988). However, they show few differences (Müh *et al.* 2012). The higher stability of bRC favored the work on the bRC-based biohybrid photoelectrochemical cells (Maksimov *et al.*

2013). Evolutionarily younger oxygenic photosynthesis was made possible by the combination of RC and oxygen-evolving complex (OEC) into a PSII (Nisbet *et al.* 2007, Shevela *et al.* 2013). OEC is evolutionary innovation that allows splitting water photosynthetically (Nelson and Yocum 2006). When the energy of four light quanta is absorbed, the splitting of two water molecules produces four electrons, four protons, and one oxygen molecule (Cox and Messinger 2013). The energy of low-potential electrons from water is insufficient for the satisfaction of plant cell needs. Due to this, PSII in living cells works in tandem with PSI (Tikhonov 2013).

PSII-comprising RC, OEC, light-harvesting complexes, and several accessory and support protein subunits, is a finely tuned molecular machine. The sophisticated RC design allows it to convert light energy with a fairly high quantum yield (Wiederrecht *et al.* 1994). At the same time, PSII is very susceptible to damage by light and heat (Wang *et al.* 1992, Hakala *et al.* 2006, Dankov *et al.* 2015). This vulnerability is related to the water-splitting ability (Wang *et al.* 1992). Nevertheless, PSII is considered a promising agent for some different applications such as PSII-based biomimetic systems (Zhang and Reisner 2020, Xuan and Li 2021). Other photosynthetic pigment-protein complexes are also of very interest in the biohybrid devices area (Nguyen and Bruce 2014, Voloshin *et al.* 2015, Plumeré and Nowaczyk 2016, Friebe and Frese 2017). There are many developments of photo-bioelectrochemical cells based on components of the photosynthetic apparatus (PA), for example, based on thylakoids, PSI complexes, bacterial RCs (Kiley *et al.* 2005, Terasaki *et al.* 2006, 2009; Faulkner *et al.* 2008, Yehezkeli *et al.* 2014, Ridge Carter *et al.* 2016, Friebe and Frese 2017, Zhang and Reisner 2020). PSI and bacterial RC has more stability in comparison to PSII (Gall *et al.* 1998, Mershin *et al.* 2012, Yehezkeli *et al.* 2013, Nguyen and Bruce 2014). However, cells based on PSII are of special interest because unlike the other components of the photosynthetic apparatus, they do not need external electron donors other than water for photoinduced redox reactions to occur (Vogt *et al.* 2015). The fact that PSII generates protons from water under visible light is of particular interest from the point of view of designing systems for the production of molecular hydrogen.

A schematic of PSII of higher plants and its cofactors is depicted in Fig. 1. PsbQ, PsbP, and PsbO subunits stabilize and optimize the water-splitting complex and its reactivity. D1 and D2 subunits bind the cofactors of RC including special chlorophyll dimer (special pair, P₆₈₀), pheophytin, quinone A, and quinone B. Antenna or light-harvesting complexes LHC 2 are responsible for the collection of light quanta and the transfer of quantum energy to the reaction center (Govindjee *et al.* 2010).

PSII-based hybrid electrode

Substrate material for PSII immobilization

In the literature, we find reports on bio-based hybrid electrodes of different designs. Gold, silver, indium tin

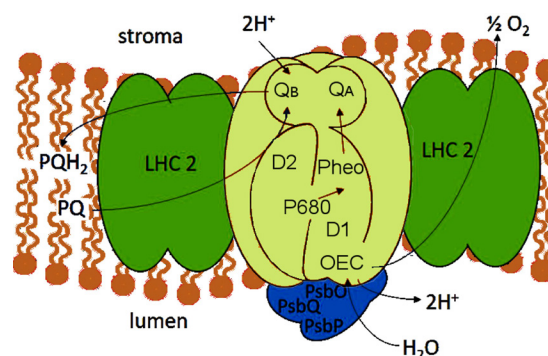

Fig. 1. The structure of the PSII. D1 and D2 are the reaction center proteins; LHC 2 – antenna light-harvesting complexes; OEC – oxygen-evolving complex; Pheo – pheophytin; PsbQ, PsbP, and PsbO – subunits of the OEC; P₆₈₀ – PSII special pair; PQ and PQH₂ – oxidized and reduced form of the mobile plastoquinone molecules; Q_A – the first bound quinone acceptor of PSII; Q_B – the second quinone acceptor. Adapted from Govindjee *et al.* (2010).

oxide, fluorine-doped tin oxide, and various forms of carbon are used as the conductive material of the electrodes (Malý *et al.* 2005b, Trammell *et al.* 2006, Kato *et al.* 2013, Friebe *et al.* 2017, Szweczyk *et al.* 2020). Let us consider in more detail the features of these materials.

Biological components should function stably after immobilization onto the electrode, and inorganic components should be resistant to corrosion processes. Therefore, an important property of the used conductive electrode materials is their chemical inertness and biological compatibility. It is known that noble metals are inert. In addition, some allotropic carbon modifications (glassy carbon, carbon fiber, graphene) and wide-gap semiconductors such as titanium dioxide have similar properties (Grätzel 1999, Walsh *et al.* 2016).

Electrode materials must meet the requirement of high electrical conductivity. Silver, gold, and other noble metals have high electrical conductivity. However, since hybrid devices need to contain no expensive components to compete with traditional energy sources, researchers are looking for more affordable materials. Semiconductor materials allow more effective electron acceptance from the reaction center in comparison to metal. It can be associated with the prohibited reverse electron transfer in the semiconductor/RC interface that is not observed in the metal/RC interface. There is no significant photoelectron transfer between metal electrode and reaction center immobilized on it due to physical adsorption (Seibert *et al.* 1982). To obtain photocurrent in metal/RC electrodes, it is necessary to connect it chemically by a special linker (Terasaki *et al.* 2006, Trammell *et al.* 2006).

Wide-gap semiconductors, such as ITO and FTO, TiO₂, are corrosion-resistant. They are often used as substrate material for electrodes (Nikandrov *et al.* 2012, Sokol *et al.* 2016, Szweczyk *et al.* 2020). The nanostructured TiO₂ layer is commonly coated onto FTO- or ITO-

glasses and such sandwich structure, in turn, adsorbs the photosynthetic material (Gizzie *et al.* 2015, Shah *et al.* 2015). ITO and FTO are applied to glass using various methods allowing the resulting conductive glass to remain transparent. Transparency is important for any photonic device. It should be noted that glasses with fluorine-doped tin oxide have an advantage over ITO glasses, since indium is not widely distributed in the Earth's crust, and this affects its cost (Frenzel *et al.* 2016).

Another important characteristic of the photoanode substrates is their specific or effective surface area (SSA) (Faure *et al.* 2013, Maksimov *et al.* 2013, Fu *et al.* 2017, Oshima *et al.* 2020). SSA is the real area of the surface that is intricately micro- and nanostructured in three-dimensional space. This term is opposed to a geometrical surface area that is a macroscopically determined area of the 2D surface (Kato *et al.* 2014). The larger SSA, the more pigment–protein complexes can be immobilized onto the surface with the same geometrical surface area. Higher loading of the substrate by RC-contained complexes leads to the increasing absorption cross-section of the photoelectrode and, as a consequence, to a higher photocurrent signal. On the one hand, high porosity substrate has a higher SSA. On the other hand, pigment–protein complexes cannot be entrapped in very small pores (Zhang and Reisner 2020). Building the electrode with appropriate SSA for the specific pigment–protein complexes loading is an important challenge for bio-based hybrid electrode design. There are many different methods to obtain nanostructured mesoporous materials with high SSA. They include salting out of the gold nanoparticles onto flat gold electrode (Terasaki *et al.* 2008, 2009), calcination of the layer of the TiO₂ paste mixed with an organic template (Lu *et al.* 2005a), anodic oxidative hydrolysis of TiCl₃ (Kavan *et al.* 1993, Lu *et al.* 2005b), aerosol-controlled vapor deposition (ACVD) process of titanium tetraisopropoxide with consequence sintering (Shah *et al.* 2015, Kavadiya *et al.* 2016), calcination of the mixing of the ITO particles with polystyrene beads to obtain electrode with inverse opal architecture (Mersch *et al.* 2015, Sokol *et al.* 2016), simple one-step pyrolysis of yeast extract and NaHCO₃ to prepare the carbon with interconnected porous networks (Tian *et al.* 2021), and others techniques.

The thickness of the electrode also affects its functionality. The large thickness of the nanostructured electrodes allows loading a larger number of RC complexes. At the same time, it should be a thin layer to minimize the electron diffusion length. Many different coating techniques are used to create a layer of conductive or semiconducting material of the desired thickness on an insulating plate. These include spin-coating, doctor-blading, screen-printing, ACVD, and others (Shah *et al.* 2012, Kato *et al.* 2014, Yu *et al.* 2015, Voloshin *et al.* 2017).

Thus, the effectiveness and feasibility of using various materials as conductive substrates for PSII complexes are determined by such properties as electrical conductivity, SSA, chemical and biological inertness, cost, and availability of the materials used.

Techniques of pigment–protein complex immobilization

The orientation of the immobilized protein complexes and the efficiency of electron transfer to the conducting surface depends on the electrode material and the method of immobilization. In some cases, to obtain a significant photocurrent, mediators are used that carry out charge transfer between RCs that do not have direct contact with the electrode and the electrode itself. The electron transfer that is realized only in the presence of a mediator is called mediated electron transfer (MET). The electron transfer directly from adsorbed pigment–protein complexes to the electrode is called direct electron transfer (DET). DET is preferable because it suggests lower resistance to electron transfer (Hasan *et al.* 2017).

The general methods of immobilization include chemical anchoring due to linker, physical adsorption, and redox-gel entrapment.

(I) Fixation of pigment–protein complexes due to special linkers: As we noted above, linker-fixation techniques are used to establish electrical contact between the pigment–protein complexes and the metal electrode. The most common RC fixation with linkers occurs on a gold electrode (Lebedev *et al.* 2006). The most commonly used linkers are the self-assembling monolayer (SAM) layer together with the Ni(II)-nitrilotriacetic acid (Terasaki *et al.* 2008).

SAM is a spontaneously formed one-molecule-thick layer on the surface of a specific substrate when the latter is immersed in a surfactant solution in an organic solvent. Since SAM formations from thiols and disulfides are known on the surface of a gold substrate, the PSII complex can be attached by covalent bonds to the finished SAM (Frolov *et al.* 2005, Malý *et al.* 2005b).

It should be noted that the efficiency of electron transfer from RC to the conductive substrate is influenced by the orientation of the pigment–protein complexes on the electrode. It was shown that the interaction of SAM with PSII, due to electrostatic or covalent forces, affects the orientation of the protein relative to the substrate. Kato *et al.* (2013) studied the photocurrent in hybrid cells based on the cyanobacteria PSII complexes. These sensitizers were electrostatically and covalently immobilized on a SAM-modified mesostructured ITO electrode. The results of the work showed that the orientation of the PSII obtained during immobilization due to electrostatic interaction provides the most efficient electron transfer. In this case, the subsequent covalent binding of such a PSII already oriented in a certain way provides higher values of the registered photocurrent than due to solely electrostatic bonds (Kato *et al.* 2013).

The use of a SAM as a linker together with Ni(II)-nitrilotriacetic acid (Ni-NTA) requires genetic modification of the protein. In the case of PSII, one should use complexes with modified CP47 or CP43 subunits (Terasaki *et al.* 2008, Noji *et al.* 2011). They must have six consecutive histidine residues (Histag) at the C-terminus. In this case, the conductive surface is covered with an organic layer, then Ni-NTA is applied. Ni-NTA has a high affinity for the

polypeptide chain in modified photosystems. The histidine-labeled PSII protein complex was covalently bound to a conductive Ni-NTA-treated gold surface (Fig. 2). In such a solar cell, according to the calculations of Vittadello *et al.* (2010), the current density should reach $43 \mu\text{A cm}^{-2}$. The interest of PSII-decorated gold electrode has been offered by Miyachi *et al.* (2017). In this system, PSII complexes were reconstituted by changing native quinone on the quinone derivative that is fixed on the platinum nanoparticle. One nanoparticle can fix multiple quinone derivatives. Thus, after the reconstruction and cross-linking agent adding, the interconnected net of the PSII complexes and Pt nanoparticle was obtained. This net was fixed onto the Au/SAM electrode. Such a system can generate 15 nA cm^{-2} at $E = +0.10 \text{ V}$ (vs. Ag/AgCl) under 680-nm irradiation (Miyachi *et al.* 2017). Despite the small current

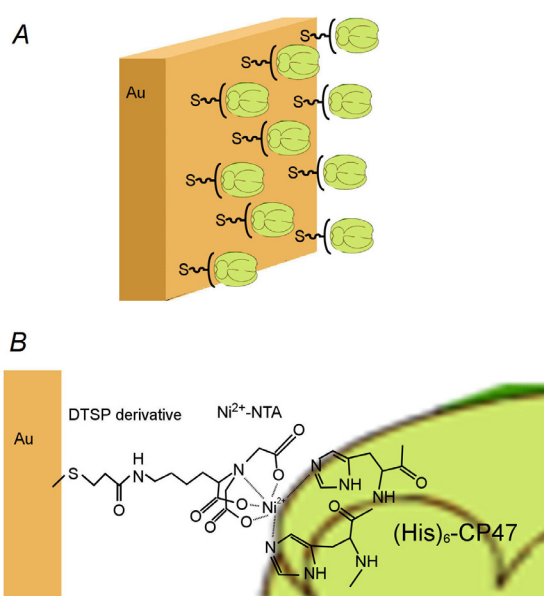

Fig. 2. Planar gold electrode with immobilized Histag-PSII through Ni-NTA SAM. General scheme (A); scheme of Histag-PSII anchoring through 3,3'-dithiodipropionic acid di(N-hydroxysuccinimide ester) (DTSP) and Ni(II)-nitrilotriacetic (Ni-NTA) (B). Adopted from Terasaki *et al.* (2008) and Noji *et al.* (2011).

value, this bio-based electrode is of interest because it used 'nanowire' between PSII complexes and the electrode. Wiring suggests the straight electron transfer: $P_{680} \rightarrow Q_A \rightarrow \text{Pt} \rightarrow \text{gold electrode}$.

It should be noted that the linker-based method of protein immobilization is expensive because it requires complex chemical and genetic modifications. However, further research in this area could lead to a reduction in the cost of this technique.

(2) Physical adsorption of pigment–protein complexes on a substrate: This method involves the use of semiconductor substrates based on nanostructured metal oxides (Fig. 3). A nanostructured layer differs from a flat one by the presence of cavities and pores several tens of nanometers in size. Nanoporous titanium dioxide (TiO_2) is most often used for solar cells because it is biocompatible and easily forms bonds with proteins through COOH groups, and the porous structure increases the strength of these bonds and increases the absorption cross-section (Yu *et al.* 2015).

Zaspa *et al.* (2020) measured photocurrent generated by PSII-based solar cell where the PSII core complexes were adsorbed onto a Millipore membrane filter (MF) on an ITO electrode. The stable and maximum photocurrent was recorded in the presence of trehalose and 2,6-dichloro-1,4-benzoquinone (DCBQ). It was suggested that the long-term retention of photoactivity at room temperature in the structure ITO | PSII-MF | ITO may be associated with the retention of water molecules attached to the PSII surface in the presence of trehalose.

Brinkert *et al.* (2016) showed that in the system PSII | TiO_2 | ITO, electron transfer occurs from the first quinone Q_A directly to the ITO-conducting surface and the transfer of electrons through the nanostructured metal oxide is the rate-limiting stage. The authors considered the possibility of using oxides of other metals with a wider band gap, such as tin dioxide (SnO_2) or tungsten trioxide (WO_3) (Brinkert *et al.* 2016). The advantages of using this method include the convenience of obtaining a nanostructured surface, a lower cost, and a larger surface area compared to a gold electrode. However, the main disadvantage is the low efficiency of electron transfer to TiO_2 and oxides of some other metals because electrons from PSII, entering the nanoporous metal oxide, have an

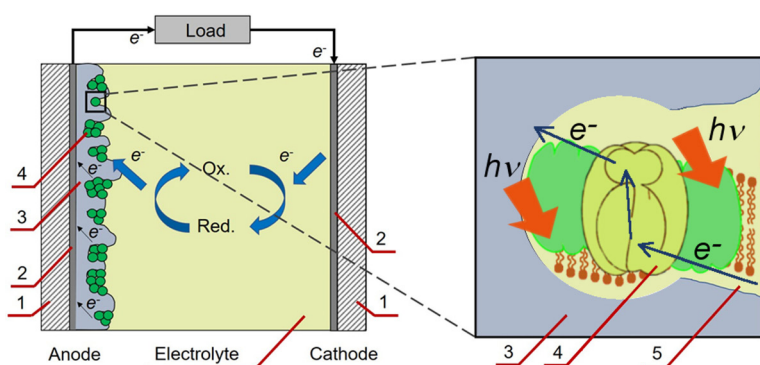

Fig. 3. An example of solar cell design based on PSII immobilized on a conductive substrate using the physical adsorption method. 1 – glass; 2 – transparent conductive spraying; 3 – nanoporous TiO_2 ; 4 – photosynthetic RC; 5 – electrolyte; RC – reaction center; Ox. – the oxidized form of the electrolyte; Red. – the reduced form of the electrolyte.

energy level below the conduction band of this material (Brinkert *et al.* 2016).

Güzel *et al.* (2020) suggest another interesting system of PSII complexes fixed onto the TiO₂ electrode due to 'bio-nano-cocktail' production. They used the amino acid (monomer) decorated and light underpinning conjugation approach for obtaining an array of the cross-linking PSII proteins with NADH linkage ruthenium-based amino acid monomer. This approach uses sensitizer properties of the chloro-bis(2-2'-bipyridyl) methacryloyl tyrosine-ruthenium(II) for the polymerization (Say *et al.* 2012). Resulted PSII-bio-nano-cocktail was used as a sensitizer for BSSC. This BSSC generated an open circuit voltage of 0.50 V, a short circuit current of 888 $\mu\text{A cm}^{-2}$, and a fill factor of 0.50 (Güzel *et al.* 2020).

Another promising method of immobilization is the creation of a hierarchically structured reverse opal conducting surface based on mesostructured indium tin oxide (IO-mesoITO). The advantage of IO-mesoITO is that it has metal-like conductivity and biocompatibility, a large surface area due to the formation of channels (Brinkert *et al.* 2016, Sokol *et al.* 2016, Tian *et al.* 2021). IO-meso electrodes are considered the last most perspective generation for biohybrid devices. IO-meso electrodes are currently the most modern and promising technology in the field of biohybrid devices (Zhang and Reisner 2020).

(3) Fixation of pigment–protein complexes in redox hydrogels: The fixation of the PSII complexes in the polymer gel helps maintain stability while increasing the surface area of the coating with pigment–protein complexes. Immobilization of the photosystem complexes in a matrix of gelatin or bovine serum albumin and glyceraldehyde is a widely used method for assembling PSII-based biosensors (Giardi *et al.* 2001). Modification of such a gel with redox agents improves the transfer of electrons to the conductive substrate since redox agents act as electronic mediators. Osmium-containing redox polymer based on poly-1-vinylimidazole is widely used for fixing the photosystem (Badura *et al.* 2008, Kothe *et al.* 2013, Sokol *et al.* 2016). In these cells, the Os-based polymer acts as an electron mediator and as a matrix for fixing PSII complexes (Fig. 4).

One of the most effective PSII-based devices has been designed by Sokol *et al.* (2016). The authors combined the immobilization method in redox polymer with a mesostructured IO-mesoITO substrate, and obtained a photocurrent of up to 410 $\mu\text{A cm}^{-2}$ without mediators and up to 513 $\mu\text{A cm}^{-2}$ in the presence of DCBQ.

Wang *et al.* (2020) observed an increase in the photocurrent density up to 70 $\mu\text{A cm}^{-2}$ in the presence of dinoterb, a phenolic inhibitor of the Q_B-binding site in PSII. In this work, PSII complexes were immobilized through a redox polymer modified with osmium on a gold substrate. The authors assume that these results are associated with the effect of the used inhibitor on the polymer film and emphasize the importance of taking into account the possible effect of additional compounds on bioelectrodes modified by a redox polymer.

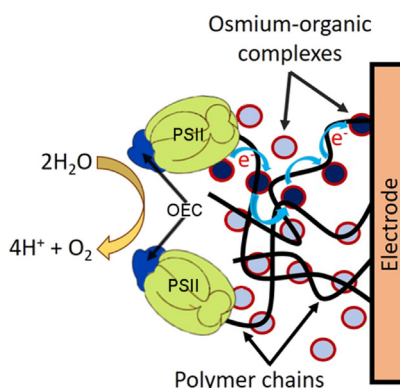

Fig. 4. An example of hybrid electrode design based on PSII complexes immobilized on a conductive substrate by a polymer gel layer containing redox agents. Adapted from Badura *et al.* (2008).

There are many different kinds of hybrid electrodes. However, it is impossible for now to choose the best one. There are no standard conditions for the hybrid photoelectrode activity measurement (Musazade *et al.* 2018).

PSII in solar-to-electricity convertors

Artificial solar-to-electricity converters are called photoelements or solar cells (Allakhverdiev *et al.* 2010b). Sometimes the terms 'photovoltaic cell' or 'photogalvanic cell' are also used (Kostic 2007, Gangotri and Bhimwal 2011). Ecological and economical obstacles of the conventional semiconductor solar cells force the scientist to design, build, and test novel devices to convert solar energy. One of the directions in this field is the incorporation of the biological pigment–protein complexes into solar cell devices. Solar cells containing pigment–protein complexes are called biohybrid solar cells (Musazade *et al.* 2018). We will use the term 'photo-bioelectrochemical cells' or PBEC. This more common term includes both photohydrogen production and photocurrent-generation devices (Rasmussen and Minter 2014, Plumeré and Nowaczyk 2016, Yehezkeli *et al.* 2016, Wey *et al.* 2019). It is worth noting that researchers have not yet come to a standard for terminology in this field.

PBEC structure

A typical PBEC consists of a hybrid photoanode, an electrolyte, and a cathode. The photoanode is a conductive or semi-conductive substrate that is sensitized by components of the photosynthetic apparatus. The cathode is also a conductive inorganic electrode. In some cases, the cathode can be functionalized with a catalyst of a biological or artificial nature. Platinum is the most common catalyst used at the cathode (Rao *et al.* 1990, Lukashev *et al.* 2007, Ihssen *et al.* 2014, Pinhassi *et al.* 2016). The main function of a cathode catalyst is to accelerate reduction reactions and/or to participate in the

synthesis of molecular fuels such as molecular hydrogen. In the latter case, the main product of the cell is not electricity but hydrogen (Barber and Tran 2013). The electrolyte transfers charge between the cathode and the photoanode sensitized by the photosystems. If such a cell is connected to an external circuit, it can generate a current under the influence of light. Light causes charge separation in the RC and photoelectrons from the RC migrate through the cofactor chain to the anode (Fig. 5). RC is recovered by electrons from electrolyte charge carriers, which, in turn, receive electrons from the cathode (Musazade *et al.* 2018). Some electrochemical cells implement a cathodic current: the RC donates an electron to a solubilized electronic mediator and accepts electrons from the electrode on which it is immobilized (Trammell *et al.* 2004, Yehezkeili *et al.* 2013).

Efficiency assessment for PBEC

The efficiency of the light energy conversion in biohybrid solar cells can be determined by distinct ways: conventional ratio of the electric power to the light power, external quantum efficiency, turnover frequency of immobilized RC. Any solar cell in addition to the efficiency terms can be described by three voltammetric parameters: short-circuit current (I_{sc}), open-circuit voltage (V_{oc}), and fill factor (FF) (Pandey *et al.* 2016). I_{sc} is the current value for the circuit with a vanishingly low resistance of the load. In the short circuit, mode voltage is equal to zero. V_{oc} is the voltage on the circuit with very high resistance to the load. In the open circuit mode, there is no current flow through the chain. In some reports about biohybrid solar cells, only short-circuit current or short-circuit

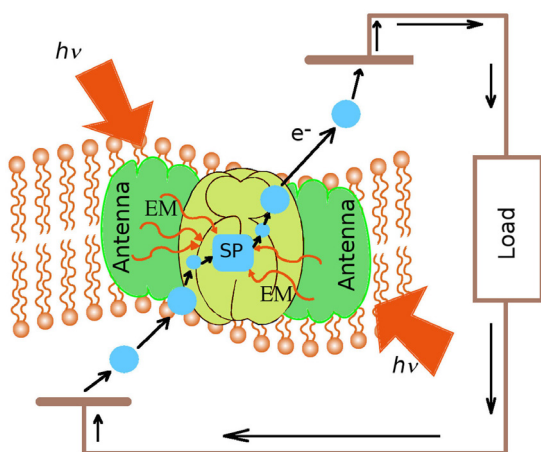

Fig. 5. The general principle of PBEC operation: light excites the antenna complexes which activates the transfer of energy through the inductive-resonant mechanism to the special pair (SP) of RC; charge separation occurs in RC; the electron is transferred through a series of carriers to the electrode and further into the external circuit; recovery of RC electrodes occurs at the expense of the second electrode. RC – reaction center. Adapted from Musazade *et al.* (2018).

current density is presented as a single characteristic of the cell (Kavadiya *et al.* 2016, Voloshin *et al.* 2019). Unfortunately, effectiveness depends not only on the short-circuit current. It can be calculated from the data of the I-V curve (Voloshin *et al.* 2016). Quantum yield (external quantum efficiency, EQE) is another useful physical quantity for evaluating efficiency. It is a more powerful quantity for spectral analysis. EQE is determined as the ratio of the number of generated photoelectrons by cell per second to the number of incident light quantum under monochromatic illumination. In contrast, internal quantum efficiency (IQE) is the ratio of the photoelectrons generated to the number of photons absorbed. For the same device and light conditions, IQE is higher than EQE (Pratiyush *et al.* 2018). IQE is more complicated for calculation than EQE. The above-mentioned methods of calculation are suitable for the comparison of solar cells. If one would like to compare the functionality of the RC immobilized into the cell with native RC, the turnover frequency or turnover number values should be exploited (Friebe and Frese 2017).

The efficiency of the PBEC depends on many factors, including the design of the developed electrode, the materials used, the methods of immobilization of the photosystem complexes, and measuring conditions. There are many works on the analysis of hybrid electrodes using a three-electrode scheme (Zhang and Reisner 2020). This scheme allows a bias voltage to be applied to the working electrode. In this scheme, the hybrid working photoelectrode consumes external energy, and the efficiency of photocurrent generation is not the efficiency of the electrode. In general, analytical three-electrode cells are not PBECs designed for energy conversion.

Overview of the PSII-based PBEC

The considered features of PSII-based cells contribute to the final efficiency of the PBEC. They affect the efficiency of light photon energy absorption by pigments, charge separation in RC, and transfer of electrons from RC to the electrode, diffusion of electrons in the electrode and ions in the electrolyte, as well as reduction of oxidized RC pigments. There are many different types of biohybrid solar cells, based on the photosynthetic RCs. They are distinct by the source of the RC, materials of the electrodes, immobilization techniques, constructions of the whole cell.

There are no standard conventional light conditions for the laboratory solar cell testing and a typical form for the presentation of results. This leads to difficulties in the scientific literature analysis (Voloshin *et al.* 2017). Despite this problem, we summarize the most interesting results for the biohybrid solar cells based on the PSII and present them in Table 1. However, since not all works report the efficiency of the PBEC, we compared these cells by the values of the photocurrent density.

According to the data presented in Table 1, we can conclude that among the presented substrate materials and immobilization methods, the least effective is the combination of an ITO substrate with PSII adsorption

Table 1. The PSII PBEC efficiencies are based on generated photocurrent densities. J – photocurrent density; ITO – indium tin oxide; DCBQ – 2,6-dichloro-1,4-benzoquinone; SAM – self-assembling monolayer; IO-mesoITO – hierarchically structured inverse opal mesoporous indium tin oxide. * – no applied bias.

	Pigment–protein complex	Working electrodes material	Light conditions	Light intensity [mW cm ⁻²]	J [μA cm ⁻²]	Reference
1	PSII from <i>T. elongatus</i>	Smooth Au Os redox polymer PSII	Halogen lamp using a 675-nm interference filter and a cold light filter	2.65	45	Badura <i>et al.</i> (2008)
2	PSII from <i>T. elongatus</i>	Mesoporous ITO SAM PSII	Red light irradiation, 679 nm	10	4.5	Kato <i>et al.</i> (2013)
3	PSII core particles from <i>T. elongatus</i> BP-1	IO-mesoITO PSII (mediated by DCBQ)	Halogen lamp, band-pass filter, 679 nm, red light	10	930	Mersch <i>et al.</i> (2015)
5	PSII core particles from <i>T. elongatus</i> BP-1	ITO TiO ₂ PSII (mediated by DCBQ)	Xenon lamp, 590 nm cut-off filter, red light	< 10	1.2	Brinkert <i>et al.</i> (2016)
6	PSII from spinach	Macroporous carbon polyethylenimine PSII (mediated by DCBQ)	Solar light simulator AM 1.5	80	7.7*	Tian <i>et al.</i> (2021)
7	PSII from spinach	ITO TiO ₂ bio-nano-coctail (PSII–ruthenium complexes)	Solar light simulator AM 1.5	100	888*	Güzel <i>et al.</i> (2020)

on titanium dioxide (Table 1, entry 1). The authors of the study associate it with ineffective electron transfer from PSII to titanium dioxide (Brinkert *et al.* 2016).

In addition, the use of SAM for immobilization of PSII (Table 1, entry 2) is also not very effective due to an energy barrier located on SAM for an electron transported from RC to a conducting substrate (Trammell *et al.* 2006, Kato *et al.* 2013). In this regard, the methods for immobilizing PSII, which provide the closest possible contact of RC with a conducting substrate, are preferable (den Hollander *et al.* 2011).

The photocurrent densities of PBEC based on PSII do not differ much on flat gold substrates using a histidine strand and osmium-modified redox polymer (Table 1, entries 3 and 4). Thus, complex modifications of PSII required for the construction of a hybrid electrode with Au | histidine-tagged PSII appears to be unattractive.

As the results shown in entries 5 and 6 of Table 1 and obtained under similar conditions, it is observed that the current density in PBEC based on PSII using osmium-modified redox polymer is about half that generated by PBEC based on core complexes without this polymer. Possibly, this is due to the smaller size of the core complexes as compared to the whole PSII, which affects the ability of the former to penetrate deeper into the structure of the conducting substrate and thereby ensure the immobilization of a larger amount of RC on the substrate (Mersch *et al.* 2015, Sokol *et al.* 2016).

Entry 7 (Table 1) demonstrates the most intriguing results obtained by Güzel *et al.* (2020). They made dye-sensitized solar cells with PSII-bio-nano-coctail that served as a dye. A sufficiently high photocurrent was generated without any external bias. Unfortunately, it is unclear whether the main contribution to the photocurrent comes from ruthenium dye or PSII.

The data shown in Table 1 indicate that the most efficient generation of photocurrent occurs in PSII-based

PBECs using mesostructured materials that enable a larger number of RCs to be absorbed.

PSII in solar-to-hydrogen convertors

Molecular hydrogen is a high-energy, clean, and renewable fuel (Babu *et al.* 2012). However, conventional production processes for H₂ require significant improvement in efficiencies, reduced capital costs, enhanced reliability, and operating flexibility (Allakhverdiev *et al.* 2009). H₂ synthesis needs proton, energy, and catalyst.

Water is a ubiquitous source of protons and PSII is a native complex that can use sunlight for water splitting into the protons and oxygen. So, PSII can take part in one of two half-reactions for hydrogen production in PBEC (Fig. 6). The main principle of this PBEC operation is to separate in space water-splitting process and H₂ synthesis reaction. PSII-based hybrid photoelectrode can be utilized in the first process proceeding in the anodic chamber. Hydrogen synthesis occurs in the cathodic chamber on the catalytic cathode. These reactions are connected in two ways. The first way is the electrical current through the external circuit. The second way is the migration of protons through the proton exchange membrane (PEM) to the cathodic chamber.

Platinum is the most common catalyst for proton reduction and can be used in tandem with photosynthetic apparatus components (Li *et al.* 2017). However, platinum is an expensive noble metal. One of the alternatives to Pt is native enzyme hydrogenase that can reduce protons and produce the hydrogen. In this case, the design of the hydrogenase cathode is an additional challenge. As in the case of PSII-electrodes, the IO-mesoITO electrodes are a contemporary solution for this issue (Mersch *et al.* 2015).

Another problem is related to the energy mismatch between the terminal electron acceptor inside PSII and

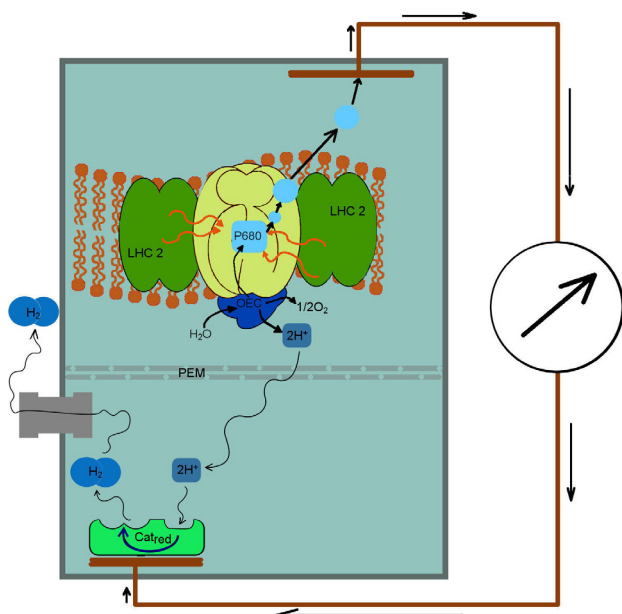

Fig. 6. The general principle of the hydrogen-producing PBEC. LHC – light-harvesting complex; OEC – oxygen-evolving complex; PEM – proton exchange membrane; Cat_{red} – reduction catalyst responsible for the H_2 synthesis. The platinum or hydrogenase can serve as Cat_{red} . The arrow in the circle on the right indicates a potentiostat that can bias the electrodes.

the Fe–S cluster inside hydrogenase (Zhang and Reisner 2020). A simple solution is to apply bias to the working electrode. Such a version is depicted in Fig. 6. However, more interesting solution is to use a second photocatalyst, in an analogy similar to the native photosynthesis. It can be PSI, photoactive semiconductor, or artificial dye (Mersch *et al.* 2015, Li *et al.* 2017, Zhang and Reisner 2020). This method will avoid unnecessary energy consumption for fuel production.

The term ‘semi-artificial photosynthesis’ is used for research direction on the solar–fuel and solar–chemical pathways in the hybrid system incorporating artificial components with native enzymes, pigment protein–complexes, or whole cells (Kornienko *et al.* 2018). Comprehensive reviews describe semi-artificial photosynthetic systems based on whole cells (Kornienko *et al.* 2018) and isolated PSII complexes (Zhang and Reisner 2020).

PSII in herbicide biosensors

The majority of the herbicide used for chemical weeding are inhibitors of the photosynthetic activity (Carpentier *et al.* 1991). Due to this, the efficiency of the photo-induced electron transfer in the PSII-based hybrid device can be used for indication of the herbicide presence in the sample. For effective detection, a biosensor must have the following properties (Conrad *et al.* 1993, Giardi *et al.* 2001):

- (1) Specificity. The sensor should allow determining the type of detected herbicides.
- (2) Reproducibility. Results obtained by the sensor should be reproduced under the same conditions.
- (3) Stability. The sensor should be reusable.
- (4) Sensitivity. The limit of detection should be satisfactory low.

There are several ways to utilize PSII complexes for herbicide detection. They include the analysis of the Hill reaction inhibition (Li *et al.* 2005), the analysis of the change in the fluorescent induction curve (Conrad *et al.* 1993), and the analysis of the photoelectric characteristics of the PSII-based hybrid electrode (Koblížek *et al.* 2002). Any biosensors require measurement of a calibration curve prior they are put into exploitation. The Langmuir adsorption isotherm is the generally accepted model for analyzing a calibration curve (Touloupakis *et al.* 2005, Masojídek *et al.* 2011).

The form of the induction curve of the chlorophyll fluorescence in PSII preparation is directly related to the photosynthetic activity of the PSII. This fact underlies the fluorimetry techniques of the photosynthetic activity assay (Lavergne and Trissl 1995, Schansker *et al.* 2011). At the moment, there are many special devices for measuring the induction curve and deeply developed interpretation protocols for analyzing this curve (Stirbet and Govindjee 2011, Kalaji *et al.* 2014, 2017; Stirbet *et al.* 2018). The herbicides inhibiting photosynthesis also affect the induction fluorescence curve (Bukhov *et al.* 2004). A powerful technique to interpret the change in the fluorescence induction curve allows using fluorescent PSII-based biosensor for the herbicide detection. The fluorescent biosensors can be distinguished into two types. The first type uses green algae as a sensing element (Conrad *et al.* 1993, Antonacci *et al.* 2021). The second type uses isolated photosynthetic membranes or PSII complex preparation (Merz *et al.* 1996, Giardi *et al.* 2005). In both types, the fluorescence signal from PSII is detected. It is worth noting that in older works, the sensitive element of the sensor was a suspension of the membrane preparation or algae cells (Conrad *et al.* 1993, Merz *et al.* 1996). In more recent works, the sensitive element was immobilized (Giardi *et al.* 2005, Antonacci *et al.* 2021). Giardi *et al.* (2005) used bovine serum albumin (BSA)-glutaraldehyde matrix and CdCl_2 matrix for immobilization. In that work, a scheme of the whole sensor system with four flow sensor cells is presented. The results of the test of this system with the river water samples were also presented. The use of both a PSII preparation from wild-type plants and mutant species resistant to atrazine in one iteration of the analysis of a sample allows the sensor to distinguish between different types of herbicides (Giardi *et al.* 2005). The work of Antonacci *et al.* (2021) is notable for the sensor design allowing simultaneous recording of fluorescence and electricity signals. Algal cells in that work were immobilized onto the paper-based screen-printed electrodes nanomodified with carbon black. A disadvantage of the fluorescent sensor is its complicated

structure: the sensor should include a sample chamber, source of the light, and fluorescence signal detector.

Photovoltaic PSII-based biosensor does not include fluorescence light detector. It contains PSII-based electrodes like those in the PBEC. However, in the biosensor, this electrode immersed into the sample solution should be exposed to the stable red light for reusable herbicide detection (Fig. 7).

Electricity signals generated by the same electrodes under the same light conditions will be affected only by herbicide inhibitory activity. There are several works with PSII-based electrodes designed by screen-printed methods (Kobližek *et al.* 2002, Malý *et al.* 2005a, Bettazzi *et al.* 2007, Masojídek *et al.* 2011). Screen printing is a relatively simple procedure for electrode system preparation. It consists of the transferring of the layout onto a substrate through the open mesh of a screen (Touloupakis *et al.* 2005). Polyvinyl chloride (PVC) is a frequently used substrate material. This technique allows the anode and cathode to be fixed on the same flat substrate. This flat two-electrode system is very useful for portable sensor devices. This technique allows preparing of either two-electrode or three-electrode schemes onto the flat substrate (Kobližek *et al.* 2002, Malý *et al.* 2005a, Touloupakis *et al.* 2005). Touloupakis *et al.* (2005) built a sensor based on the spinach thylakoids with a half-life of about 17 h and a limit of detection of about 10^{-8} M for diuron, atrazine, simazine, and several other herbicides. They used the BSA-glutaraldehyde matrix for membrane immobilization and duroquinone as an exogenic mediator. After each measurement, the biosensor had to be rinsed by buffer with mediators. This sensor was tested on herbicide detection in river water (Touloupakis *et al.* 2005). At the working electrode, PSII-containing membranes immobilized into glutaraldehyde matrix were deposited onto the carbon electrode. Using another PSII-based biosensor, Malý *et al.* (2005a) measured the stability of isoproturon at different soil depths. PSII-based biosensors are promising probes for specific and rapid detection of herbicides.

H₂ photoproduction in the systems mimicking PSII

The concept of semi-artificial photosynthesis embrace systems for fuel synthesis cost by the light that should

overcome the limitations of natural enzyme complexes and fully man-made systems (Kornienko *et al.* 2018). However, the main challenge of the natural system – its low stability – is rather difficult to solve. For now, the most longevous PSII-based electrode allowed the stable output for 5 d (Tian *et al.* 2021). Design of the fully artificial system that mimics the process that occurred in the native photosystem is an actively developed area. The scheme of such system aimed at hydrogen production is depicted in Fig. 8. Like a PBEC in Fig. 6, it includes two parts: donor part and acceptor part. Water oxidation on the donor part provides electrons for the reduction of protons that occurs on the acceptor part.

The main three components of the artificial photosynthesis system include photosensitizer, water-splitting catalyst, and proton-reduction catalyst. It is believed that artificial photosynthesis began to develop thanks to the work of Fujishima and Honda (1972), who observed UV-induced decomposition of water into protons and oxygen in titanium dioxide (Fujishima and Honda 1972, Barber and Tran 2013). Since then, the photocatalytic properties of semiconductors, both pure and sensitized with synthetic dyes, have been actively studied. The most popular semiconductor in this field has been titanium dioxide. However, pure TiO₂ has some disadvantages that can be eliminated by several additives.

Combining tungsten oxide (WO₃) semiconductor nanomaterials with the Mn-oxo catalyst as a PBEC system can overcome a key challenge in using semiconductors directly, which is the low catalytic activity of semiconductors. For example, the surface of WO₃ semiconductor may be coated with the Mn-oxo oligomer catalyst by thermal treatment of a solution of the Mn-oxo dimer compound (Liu *et al.* 2011). The preparation took typically 5 min and did not cause noticeable colorization of WO₃. Deposition of the Mn catalyst is preferred for at least three reasons: (1) deposition is straightforward, (2) the coating does not compete with WO₃ in light absorption, and (3) the catalyst facilitates hole transfer from the semiconductor to the solution. The working hypothesis is similar to PSII. The light radiation is absorbed by the WO₃ semiconductor as P₆₈₀ in PSII and causes a charge separation to produce electrons and holes. The electrons may be transferred to the cathode by an electric wire to

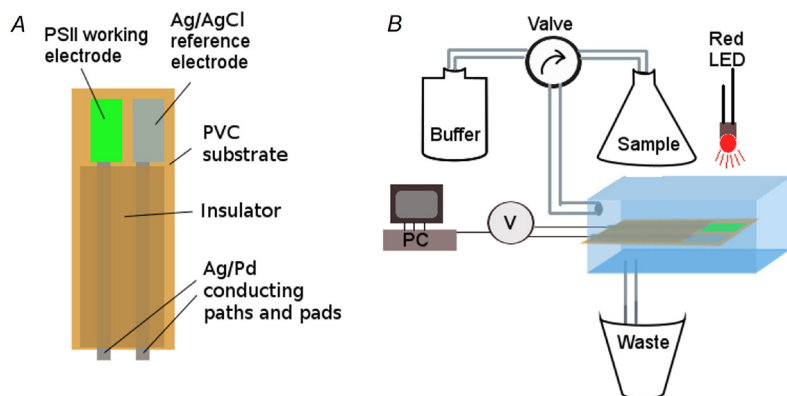

Fig. 7. Biosensing chip based on the two-electrode scheme (A). Simplified scheme of the whole sensing system (B). PVC – polyvinyl chloride; V – voltmeter. Adopted from Kobližek *et al.* (2002) and Touloupakis *et al.* (2005).

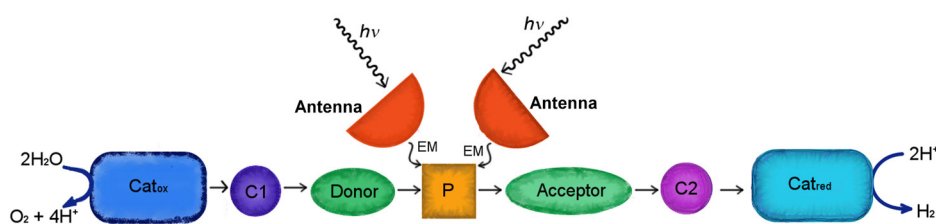

Fig. 8. Scheme of the artificial photosystem. Cat_{red} – catalyst for chemical H_2 reduction, Cat_{ox} – catalyst for chemical water oxidation; C1 and C2 – electron carriers on the donor and acceptor parts; P – photosensitizer. Adapted from Allakhverdiev *et al.* (2010a).

produce hydrogen gas in a photoelectrochemical cell. Donating electrons to the holes, the Mn-oxo oligomer can extract electrons from water to evolve molecular oxygen following the catalytic mechanism described (Chou *et al.* 2012).

Artificial photosynthesis is not limited by photoinduced water splitting. There are many variants of hydrogen synthesis catalysts and photosensibilizers based on the ruthenium complexes or quantum dots. Allakhverdiev *et al.* (2010a) and McConnell *et al.* (2010) have presented comprehensive reviews on artificial photosynthesis for hydrogen production.

Conclusion: The water-splitting reaction in PSII driven by sunlight in plants, algae, and cyanobacteria stores a vast amount of solar energy and provides vital oxygen to life on the Earth. The use of PSII holds promise in several applications. Unfortunately, the photocurrent signal received from the PSII electrodes is very weak and, in many cases, requires external bias. At the same time, there are many prospects for the development of various hybrid electrodes. Reisner's group is actively developing inverse opal IO-mesoITO electrodes with a hierarchical structure and has high hopes for them (Mersch *et al.* 2015, Sokol *et al.* 2016, Zhang *et al.* 2016). At the moment, this kind of PSII-based electrode seems to generate the highest photoelectric signals. IO-mesoITO electrodes can be used also for hydrogenase immobilization. Mersch *et al.* (2015) demonstrated the production of photohydrogen with 5.4% efficiency in a PBEC combining IO-mesoITO | PSII photoanode and IO-mesoITO | hydrogenase cathode. Another interesting topic requiring further development is the synthesis of PSII-bio-nano-cocktail. Güzel *et al.* (2020) suggest that PSII complexes in such bio-nano-cocktails will be more stable.

To date, there are no examples of PBEC based on bRC fixed on IO-mesoITO substrates in the literature; however, considering the efficiency of such design of electrodes with PSII, similar PBECs based on bRC will probably also show the high efficiency of photocurrent generation (Friebe and Frese 2017). The efficiency of solar cells based on bacterial RC may be even higher since the RC has a smaller size and can penetrate the channels of the mesoporous substrate.

In the herbicide photo-bioelectrochemical sensor area, research in recent years has been focusing on the use of the whole photosynthetic organisms instead of isolated PSII complexes (Tucci *et al.* 2019, Antonacci *et al.* 2021). There are many achievements in artificial photosynthesis for now. We have seen significant progress

in photoelectrochemical water splitting using Mn-oxo complexes and Co-based molecular catalysts (Dogutan and Nocera 2019, He *et al.* 2019, Spies *et al.* 2019, Hou 2021). In particular, the Mn/Nafion, Mn/TiO₂, Mn/WO₃, Co/Fe₂O₃, Co/ZnO systems developed may be extended to heterostructures of a variety of semiconductors (He *et al.* 2019, Spies *et al.* 2019, Hou 2021). The protocols are suited for preparing earth-abundant metal/semiconductor catalysts.

Semi-artificial and artificial photosynthesis must be developed side by side. Identifying the processes occurring at the enzyme/electrode interface should provide more inspiration and information for creating an artificial stable system.

References

- Allakhverdiev S.I., Kreslavski V.D., Thavasi V. *et al.*: Hydrogen photoproduction by use of photosynthetic organisms and biomimetic systems. – *Photoch. Photobio. Sci.* **8**: 148-156, 2009.
- Allakhverdiev S.I., Kreslavski V., Thavasi V. *et al.*: Photosynthetic energy conversion: Hydrogen photoproduction by natural and biomimetic means. – In: Mukherjee A. (ed.): *Biomimetics Learning from Nature*. Pp. 49-75. InTech 2010a.
- Allakhverdiev S.I., Thavasi V., Kreslavski V.D. *et al.*: Photosynthetic hydrogen production. – *J. Photoch. Photobio. C* **11**: 101-113, 2010b.
- Allen M.J.: Direct conversion of radiant into electrical energy using plant systems. – In: Buvat R., Allen M.J., Massué J.-P. (ed.): *Living Systems As Energy Converters. Proceedings of the European Conference on Living Systems as Energy Converters*. Pp. 271-274. Elsevier 1977.
- Antonacci A., Attaallah R., Arduini F. *et al.*: A dual electro-optical biosensor based on *Chlamydomonas reinhardtii* immobilised on paper-based nanomodified screen-printed electrodes for herbicide monitoring. – *J. Nanobiotechnology* **19**: 145, 2021.
- Babu V.J., Kumar M.K., Nair A.S. *et al.*: Visible light photocatalytic water splitting for hydrogen production from N-TiO₂ rice grain shaped electrospun nanostructures. – *Int. J. Hydrogen Energ.* **37**: 8897-8904, 2012.
- Badura A., Guschin D., Esper B. *et al.*: Photo-induced electron transfer between photosystem 2 via cross-linked redox hydrogels. – *Electroanalysis* **20**: 1043-1047, 2008.
- Barber J., Tran P.D.: From natural to artificial photosynthesis. – *J. R. Soc. Interface* **10**: 20120984, 2013.
- Bettazzi F., Laschi S., Mascini M.: One-shot screen-printed thylakoid membrane-based biosensor for the detection of photosynthetic inhibitors in discrete samples. – *Anal. Chim. Acta* **589**: 14-21, 2007.
- Brinkert K., Le Formal F., Li X. *et al.*: Photocurrents from photosystem II in a metal oxide hybrid system: Electron transfer pathways. – *BBA-Bioenergetics* **1857**: 1497-1505, 2016.

- Bukhov N.G., Egorova E.A., Govindachary S., Carpentier R.: Changes in polyphasic chlorophyll *a* fluorescence induction curve upon inhibition of donor or acceptor side of photosystem II in isolated thylakoids. – *BBA-Bioenergetics* **1657**: 121-130, 2004.
- Carpentier R., Loranger C., Chartrand J., Purcell M.: Photoelectrochemical cell containing chloroplast membranes as a biosensor for phytotoxicity measurement. – *Anal. Chim. Acta* **249**: 55-60, 1991.
- Chen H., Blaber M.G., Standridge S.D. *et al.*: Computational modeling of plasmon-enhanced light absorption in a multicomponent dye sensitized solar cell. – *J. Phys. Chem. C* **116**: 10215-10221, 2012.
- Chou L.Y., Liu R., He W. *et al.*: Direct oxygen and hydrogen production by photo water splitting using a robust bioinspired manganese-oxo oligomer complex/tungsten oxide catalytic system. – *Int. J. Hydrogen Energ.* **37**: 8889-8896, 2012.
- Conrad R., Büchel C., Wilhelm C. *et al.*: Changes in yield of *in-vivo* fluorescence of chlorophyll *a* as a tool for selective herbicide monitoring. – *J. Appl. Phycol.* **5**: 505-516, 1993.
- Cox N., Messinger J.: Reflections on substrate water and dioxygen formation. – *BBA-Bioenergetics* **1827**: 1020-1030, 2013.
- Dankov K., Rashkov G., Misra A.N., Apostolova E.L.: Temperature sensitivity of photosystem II in isolated thylakoid membranes from fluridone-treated pea leaves. – *Turk. J. Bot.* **39**: 420-428, 2015.
- den Hollander M.J., Magis J.G., Fuchsenger P. *et al.*: Enhanced photocurrent generation by photosynthetic bacterial reaction centers through molecular relays, light-harvesting complexes, and direct protein-gold interactions. – *Langmuir* **27**: 10282-10294, 2011.
- Dogutan D.K., Nocera D.G.: Artificial photosynthesis at efficiencies greatly exceeding that of natural photosynthesis. – *Acc. Chem. Res.* **52**: 3143-3148, 2019.
- Drachev L.A., Kondrashin A.A., Samuilov V.D., Skulachev V.P.: Generation of electric potential by reaction center complexes from *Rhodospirillum rubrum*. – *FEBS Lett.* **50**: 219-222, 1975.
- Emerson R., Chalmers R., Cederstrand C.: Some factors influencing the long-wave limit of photosynthesis. – *P. Natl. Acad. Sci. USA* **43**: 133-143, 1957.
- Faulkner C.J., Lees S., Ciesielski P.N. *et al.*: Rapid assembly of photosystem I monolayers on gold electrodes. – *Langmuir* **24**: 8409-8412, 2008.
- Faure B., Salazar-Alvarez G., Ahniyaz A. *et al.*: Dispersion and surface functionalization of oxide nanoparticles for transparent photocatalytic and UV-protecting coatings and sunscreens. – *Sci. Technol. Adv. Mater.* **14**: 023001, 2013.
- Frenzel M., Hirsch T., Gutzmer J.: Gallium, germanium, indium, and other trace and minor elements in sphalerite as a function of deposit type – A meta-analysis. – *Ore Geol. Rev.* **76**: 52-78, 2016.
- Friebe V.M., Frese R.N.: Photosynthetic reaction center-based biophotovoltaics. – *Curr. Opin. Electrochem.* **5**: 126-134, 2017.
- Friebe V.M., Millo D., Swainsbury D.J.K. *et al.*: Cytochrome *c* provides an electron-funneling antenna for efficient photocurrent generation in a reaction center biophotocathode. – *ACS Appl. Mater. Interfaces* **9**: 23379-23388, 2017.
- Frolov L., Rosenwaks Y., Carmeli C., Carmeli I.: Fabrication of a photoelectronic device by direct chemical binding of the photosynthetic reaction center protein to metal surfaces. – *Adv. Mater.* **17**: 2434-2437, 2005.
- Fu H.-Y., Picot D., Choquet Y. *et al.*: Redesigning the Q_A binding site of Photosystem II allows reduction of exogenous quinones. – *Nat. Commun.* **8**: 15274, 2017.
- Fujishima A., Honda K.: Electrochemical photolysis of water at a semiconductor electrode. – *Nature* **238**: 37-38, 1972.
- Gall B., Zehetner A., Scherz A., Scheer H.: Modification of pigment composition in the isolated reaction center of photosystem II. – *FEBS Lett.* **434**: 88-92, 1998.
- Gangotri K.M., Bhimwal M.K.: The photochemical conversion of solar energy into electrical energy: Eosin-fructose system. – *Environ. Prog. Sustain. Energy* **30**: 493-499, 2011.
- Giardi M.T., Guzzella L., Euzet P. *et al.*: Detection of herbicide subclasses by an optical multibiosensor based on an array of photosystem II mutants. – *Environ. Sci. Technol.* **39**: 5378-5384, 2005.
- Giardi M.T., Koblížek M., Masojídek J.: Photosystem II-based biosensors for the detection of pollutants. – *Biosens. Bioelectron.* **16**: 1027-1033, 2001.
- Gizzie E.A., Scott Niezgodá J., Robinson M.T. *et al.*: Photosystem I-polyaniline/TiO₂ solid-state solar cells: simple devices for biohybrid solar energy conversion. – *Energy Environ. Sci.* **8**: 3572-3576, 2015.
- Govindjee, Kern J.F., Messinger J., Whitmarsh J.: Photosystem II. – In: *Encyclopedia of Life Sciences*. Pp. 1-15. John Wiley & Sons, Ltd, Chichester 2010.
- Grätzel M.: Mesoporous oxide junctions and nanostructured solar cells. – *Curr. Opin. Colloid Interface Sci.* **4**: 314-321, 1999.
- Grätzel M.: Photoelectrochemical cells. – *Nature* **414**: 338-344, 2001.
- Grätzel M.: Photovoltaic and photoelectrochemical conversion of solar energy. – *Philos. T. Roy. Soc. A* **365**: 993-1005, 2007.
- Güzel R., Yediyıldız F., Ocak Y.S. *et al.*: Photosystem (PSII)-based hybrid nanococktails for the fabrication of BIO-DSSC and photo-induced memory device. – *J. Photoch. Photobio. A Chem.* **401**: 112743, 2020.
- Hakala M., Rantamäki S., Puputti E.M. *et al.*: Photoinhibition of manganese enzymes: Insights into the mechanism of photosystem II photoinhibition. – *J. Exp. Bot.* **57**: 1809-1816, 2006.
- Hasan K., Grippo V., Sperling E. *et al.*: Evaluation of photocurrent generation from different photosynthetic organisms. – *ChemElectroChem* **4**: 412-417, 2017.
- He Y., Hamann T., Wang D.: Thin film photoelectrodes for solar water splitting. – *Chem. Soc. Rev.* **48**: 2182-2215, 2019.
- Hou H.J.M.: Toward molecular mechanisms of solar water splitting in semiconductor/manganese materials and photosystem II. – In: Shen J.R., Satoh K., Allakhverdiev S.I. (ed.): *Photosynthesis: Molecular Approaches to Solar Energy Conversion. Advances in Photosynthesis and Respiration (Including Bioenergy and Related Processes)*. Vol. 47. Pp. 105-129. Springer, Cham 2021.
- IEA: World Energy Outlook 2019. IEA, Paris 2019.
- Ihssen J., Braun A., Faccio G. *et al.*: Light harvesting proteins for solar fuel generation in bioengineered photoelectrochemical cells. – *Curr. Protein Pept. Sci.* **15**: 374-384, 2014.
- Kalaji H.M., Schansker G., Brestic M. *et al.*: Frequently asked questions about chlorophyll fluorescence, the sequel. – *Photosynth. Res.* **132**: 13-66, 2017.
- Kalaji H.M., Schansker G., Ladle R.J. *et al.*: Frequently asked questions about *in vivo* chlorophyll fluorescence: Practical issues. – *Photosynth. Res.* **122**: 121-158, 2014.
- Kato M., Cardona T., Rutherford A.W., Reisner E.: Covalent immobilization of oriented photosystem II on a nanostructured electrode for solar water oxidation. – *J. Am. Chem. Soc.* **135**: 10610-10613, 2013.
- Kato M., Zhang J.Z., Paul N., Reisner E.: Protein film photoelectrochemistry of the water oxidation enzyme

- photosystem II. – Chem. Soc. Rev. **43**: 6485-6497, 2014.
- Kavadiya S., Chadha T.S., Liu H. *et al.*: Directed assembly of the thylakoid membrane on nanostructured TiO₂ for a photoelectrochemical cell. – Nanoscale **8**: 1868-1872, 2016.
- Kavan L., O'Regan B., Kay A., Grätzel M.: Preparation of TiO₂ (anatase) films on electrodes by anodic oxidative hydrolysis of TiCl₃. – J. Electroanal. Chem. **346**: 291-307, 1993.
- Kiley P., Zhao X., Vaughn M. *et al.*: Self-assembling peptide detergents stabilize isolated photosystem I on a dry surface for an extended time. – PLoS Biol. **3**: e230, 2005.
- Koblížek M., Malý J., Masojídek J. *et al.*: A biosensor for the detection of triazine and phenylurea herbicides designed using Photosystem II coupled to a screen-printed electrode. – Biotechnol. Bioeng. **78**: 110-116, 2002.
- Kornienko N., Zhang J.Z., Sakimoto K.K. *et al.*: Interfacing nature's catalytic machinery with synthetic materials for semi-artificial photosynthesis. – Nat. Nanotechnol. **13**: 890-899, 2018.
- Kostic M.M.: Energy : Global and Historical Background. – In: Capehart B.L. (ed.): Encyclopedia of Energy Engineering. Pp. 1-15. Taylor & Francis/Marcel Dekker 2007.
- Kothe T., Plumeré N., Badura A. *et al.*: Combination of a photosystem 1-based photocathode and a photosystem 2-based photoanode to a Z-scheme mimic for biophotovoltaic applications. – Angew. Chem. Int. Ed. **52**: 14233-14236, 2013.
- Kumar P., Kuppam C. (eds.): Bioelectrochemical Systems. Pp. 326. Springer Singapore, Singapore 2020.
- Lavergne J., Trissl H.W.: Theory of fluorescence induction in photosystem II: derivation of analytical expressions in a model including exciton-radical-pair equilibrium and restricted energy transfer between photosynthetic units. – Biophys. J. **68**: 2474-2492, 1995.
- Lebedev N., Trammell S.A., Spano A. *et al.*: Conductive wiring of immobilized photosynthetic reaction center to electrode by cytochrome *c*. – J. Am. Chem. Soc. **128**: 12044-12045, 2006.
- Lewis N.S., Nocera D.G.: Powering the planet: chemical challenges in solar energy utilization. – P. Natl. Acad. Sci. USA **103**: 15729-15735, 2006.
- Li J., Wei X., Peng T.: Fabrication of herbicide biosensors based on the inhibition of enzyme activity that catalyzes the scavenging of hydrogen peroxide in a thylakoid membrane. – Anal. Sci. **21**: 1217-1222, 2005.
- Li Z., Wang W., Ding C. *et al.*: Biomimetic electron transport via multiredox shuttles from photosystem II to a photoelectrochemical cell for solar water splitting. – Energy Environ. Sci. **10**: 765-771, 2017.
- Liu R., Lin Y., Chou L.-Y. *et al.*: Water splitting by tungsten oxide prepared by atomic layer deposition and decorated with an oxygen-evolving catalyst. – Angew. Chem. Int. Ed. **50**: 499-502, 2011.
- Lu Y., Yuan M., Liu Y. *et al.*: Photoelectric performance of bacteria photosynthetic proteins entrapped on tailored mesoporous WO₃-TiO₂ films. – Langmuir **21**: 4071-4076, 2005a.
- Lu Y.D., Liu Y., Xu J.J. *et al.*: Bio-nanocomposite photoelectrode composed of the bacteria photosynthetic reaction center entrapped on a nanocrystalline TiO₂ matrix. – Sensors-Basel **5**: 258-265, 2005b.
- Lukashev E.P., Nadtochenko V.A., Permenova E.P. *et al.*: Electron phototransfer between photosynthetic reaction centers of the bacteria *Rhodobacter sphaeroides* and semiconductor mesoporous TiO₂ films. – Dokl. Biochem. Biophys. **415**: 211-216, 2007.
- Maksimov E.G., Lukashev E.P., Seifullina N.K. *et al.*: Photophysical properties of hybrid complexes of quantum dots and reaction centers of purple photosynthetic bacteria *Rhodobacter sphaeroides* adsorbed on crystalline mesoporous TiO₂ films. – Nanotechnol. Russ. **8**: 423-431, 2013.
- Malý J., Klem K., Lukavská A., Masojídek J.: Degradation and movement in soil of the herbicide isoproturon analyzed by a Photosystem II-based biosensor. – J. Environ. Qual. **34**: 1780-1788, 2005a.
- Malý J., Krejčí J., Ilie M. *et al.*: Monolayers of photosystem II on gold electrodes with enhanced sensor response – effect of porosity and protein layer arrangement. – Anal. Bioanal. Chem. **381**: 1558-1567, 2005b.
- Masojídek J., Souček P., Máchová J. *et al.*: Detection of photosynthetic herbicides: Algal growth inhibition test vs. electrochemical photosystem II biosensor. – Ecotox. Environ. Safe. **74**: 117-122, 2011.
- McConnell I., Li G., Brudvig G.W.: Energy conversion in natural and artificial photosynthesis. – Chem. Biol. **17**: 434-447, 2010.
- Mersch D., Lee C.Y., Zhang J.Z. *et al.*: Wiring of photosystem II to hydrogenase for photoelectrochemical water splitting. – J. Am. Chem. Soc. **137**: 8541-8549, 2015.
- Mershin A., Matsumoto K., Kaiser L. *et al.*: Self-assembled photosystem-I biophotovoltaics on nanostructured TiO₂ and ZnO. – Sci. Rep.-UK **2**: 234, 2012.
- Merz D., Geyer M., Moss D.A., Ache H.-J.: Chlorophyll fluorescence biosensor for the detection of herbicides. – Fresenius J. Anal. Chem. **354**: 299-305, 1996.
- Michel H., Deisenhofer J.: Relevance of the photosynthetic reaction center from purple bacteria to the structure of photosystem II. – Biochemistry **27**: 1-7, 1988.
- Miyachi M., Ikehira S., Nishiori D. *et al.*: Photocurrent generation of reconstituted photosystem ii on a self-assembled gold film. – Langmuir **33**: 1351-1358, 2017.
- Müh F., Glöckner C., Hellmich J., Zouni A.: Light-induced quinone reduction in photosystem II. – BBA-Bioenergetics **1817**: 44-65, 2012.
- Musazade E., Voloshin R.A., Brady N. *et al.*: Biohybrid solar cells: Fundamentals, progress, and challenges. – J. Photoch. Photobio. C **35**: 134-156, 2018.
- Nelson N., Yocum C.F.: Structure and function of photosystems I and II. – Annu. Rev. Plant Biol. **57**: 521-565, 2006.
- Nguyen K., Bruce B.D.: Growing green electricity: Progress and strategies for use of Photosystem I for sustainable photovoltaic energy conversion. – BBA-Bioenergetics **1837**: 1553-1566, 2014.
- Nikandrov V.V., Borisova Y.V., Bocharov E.A. *et al.*: Photochemical properties of photosystem I immobilized in a mesoporous semiconductor matrix. – High Energy Chem. **46**: 200-205, 2012.
- Nisbet E.G., Grassineau N.V., Howe C.J. *et al.*: The age of Rubisco: The evolution of oxygenic photosynthesis. – Geobiology **5**: 311-335, 2007.
- Nishiori D., Zhu W., Salles R. *et al.*: Photosensing system using photosystem I and gold nanoparticle on graphene field-effect transistor. – ACS Appl. Mater. Interfaces **11**: 42773-42779, 2019.
- Noji T., Suzuki H., Gotoh T. *et al.*: Photosystem II-gold nanoparticle conjugate as a nanodevice for the development of artificial light-driven water-splitting systems. – J. Phys. Chem. Lett. **2**: 2448-2452, 2011.
- Oshima T., Nishioka S., Kikuchi Y. *et al.*: An artificial Z-scheme constructed from dye-sensitized metal oxide nanosheets for visible light-driven overall water splitting. – J. Am. Chem. Soc. **142**: 8412-8420, 2020.
- Packham N.K., Packham C., Mueller P. *et al.*: Reconstitution de photochemically active reaction centers in planar phospholipid membranes. Light-induced electrical currents under voltage-clamped conditions. – FEBS Lett. **110**: 101-106, 1980.

- Pandey A.K., Tyagi V.V., Selvaraj J.A. *et al.*: Recent advances in solar photovoltaic systems for emerging trends and advanced applications. – *Renew. Sust. Energ. Rev.* **53**: 859-884, 2016.
- Pinhassi R.I., Kallmann D., Saper G. *et al.*: Hybrid bio-photo-electro-chemical cells for solar water splitting. – *Nat. Commun.* **7**: 12552, 2016.
- Plumeré N., Nowaczyk M.M.: Biophotoelectrochemistry of photosynthetic proteins. – In: Jeuken L. (ed.): *Biophotoelectrochemistry: From Bioelectrochemistry to Biophotovoltaics. Advances in Biochemical Engineering/Biotechnology*. Vol. 158. Pp. 111-136. Springer, Cham 2016.
- Pratiyush A.S., Krishnamoorthy S., Muralidharan R. *et al.*: Advances in Ga₂O₃ solar-blind UV photodetectors. – In: Pearton S., Ren F., Mastro M. (ed.): *Gallium Oxide: Technology, Devices and Applications*. Pp. 369-399. Elsevier, Amsterdam 2018.
- Rao K.K., Hall D.O., Vlachopoulos N. *et al.*: Photoelectrochemical responses of photosystem II particles immobilized on dye-derivatized TiO₂ films. – *J. Photoch. Photobio. B* **5**: 379-389, 1990.
- Rasmussen M., Minter S.D.: Photobioelectrochemistry: Solar energy conversion and biofuel production with photosynthetic catalysts. – *J. Electrochem. Soc.* **161**: H647-H655, 2014.
- Ridge Carter J., Baker D.R., Austin Witt T. *et al.*: Enhanced photocurrent from Photosystem I upon *in vitro* truncation of the antennae chlorophyll. – *Photosynth. Res.* **127**: 161-170, 2016.
- Rodionova M.V., Poudyal R.S., Tiwari I. *et al.*: Biofuel production: Challenges and opportunities. – *Int. J. Hydrogen Energ.* **42**: 8450-8461, 2017.
- Say R., Kılıç G.A., Özcan A.A. *et al.*: Bioconjugated and cross-linked bionanostructures for bifunctional immunohistochemical labeling. – *Microsc. Microanal.* **18**: 324-330, 2012.
- Schansker G., Tóth S.Z., Kovács L. *et al.*: Evidence for a fluorescence yield change driven by a light-induced conformational change within photosystem II during the fast chlorophyll *a* fluorescence rise. – *BBA-Bioenergetics* **1807**: 1032-1043, 2011.
- Seibert M., Janzen A.F., Kendall-Tobias M.: Light-induced electron transport across semiconductor electrode/reaction-center film/electrolyte interfaces. – *Photochem. Photobiol.* **35**: 193-200, 1982.
- Shah V.B., Henson W.R., Chadha T.S. *et al.*: Linker-free deposition and adhesion of photosystem I onto nanostructured TiO₂ for biohybrid photoelectrochemical cells. – *Langmuir* **31**: 1675-1682, 2015.
- Shah V.B., Orf G.S., Reisch S. *et al.*: Characterization and deposition of various light-harvesting antenna complexes by electrospray atomization. – *Anal. Bioanal. Chem.* **404**: 2329-2338, 2012.
- Shevela D., Björn L.O., Govindjee: Oxygenic Photosynthesis. – In: Razeghifard R. (ed.): *Natural and Artificial Photosynthesis: Solar Power as an Energy Source*. Pp. 13-63. John Wiley & Sons Inc., Hoboken 2013.
- Sokol K.P., Mersch D., Hartmann V. *et al.*: Rational wiring of photosystem II to hierarchical indium tin oxide electrodes using redox polymers. – *Energy Environ. Sci.* **9**: 3698-3709, 2016.
- Spies J.A., Perets E.A., Fisher K.J. *et al.*: Collaboration between experiment and theory in solar fuels research. – *Chem. Soc. Rev.* **48**: 1865-1873, 2019.
- Stirbet A., Govindjee: On the relation between the Kautsky effect (chlorophyll *a* fluorescence induction) and Photosystem II: Basics and applications of the OJIP fluorescence transient. – *J. Photoch. Photobio. B* **104**: 236-257, 2011.
- Stirbet A., Lazár D., Kromdijk J., Govindjee: Chlorophyll *a* fluorescence induction: Can just a one-second measurement be used to quantify abiotic stress responses? – *Photosynthetica* **56**: 86-104, 2018.
- Szewczyk S., Białek R., Burdziński G., Gibasiewicz K.: Photovoltaic activity of electrodes based on intact photosystem I electrodeposited on bare conducting glass. – *Photosynth. Res.* **144**: 1-12, 2020.
- Terasaki N., Iwai M., Yamamoto N. *et al.*: Photocurrent generation properties of Histag-photosystem II immobilized on nanostructured gold electrode. – *Thin Solid Films* **516**: 2553-2557, 2008.
- Terasaki N., Yamamoto N., Hiraga T. *et al.*: Fabrication of novel photosystem I-gold nanoparticle hybrids and their photocurrent enhancement. – *Thin Solid Films* **499**: 153-156, 2006.
- Terasaki N., Yamamoto N., Hiraga T. *et al.*: Plugging a molecular wire into photosystem I: Reconstitution of the photoelectric conversion system on a gold electrode. – *Angew. Chem. Int. Ed.* **48**: 1585-1587, 2009.
- Tian W., Zhang H., Sibbons J. *et al.*: Photoelectrochemical water oxidation and longevous photoelectric conversion by a photosystem II electrode. – *Adv. Energy Mater.* **11**: 2100911, 2021.
- Tikhonov A.N.: pH-Dependent regulation of electron transport and ATP synthesis in chloroplasts. – *Photosynth. Res.* **116**: 511-534, 2013.
- Touloupakis E., Giannoudi L., Piletsky S.A. *et al.*: A multi-biosensor based on immobilized Photosystem II on screen-printed electrodes for the detection of herbicides in river water. – *Biosens. Bioelectron.* **20**: 1984-1992, 2005.
- Trammell S.A., Spano A., Price R., Lebedev N.: Effect of protein orientation on electron transfer between photosynthetic reaction centers and carbon electrodes. – *Biosens. Bioelectron.* **21**: 1023-1028, 2006.
- Trammell S.A., Wang L., Zullo J.M. *et al.*: Orientated binding of photosynthetic reaction centers on gold using Ni-NTA self-assembled monolayers. – *Biosens. Bioelectron.* **19**: 1649-1655, 2004.
- Tucci M., Bombelli P., Howe C.J. *et al.*: A storable mediatorless electrochemical biosensor for herbicide detection. – *Microorganisms* **7**: 630, 2019.
- Vittadello M., Gorbunov M.Y., Mastrogianni D.T. *et al.*: Photoelectron generation by photosystem II core complexes tethered to gold surfaces. – *ChemSusChem* **3**: 471-475, 2010.
- Vogt L., Vinyard D.J., Khan S., Brudvig G.W.: Oxygen-evolving complex of Photosystem II: An analysis of second-shell residues and hydrogen-bonding networks. – *Curr. Opin. Chem. Biol.* **25**: 152-158, 2015.
- Voloshin R.A., Bedbenov V.S., Gabrielyan D.A. *et al.*: Optimization and characterization of TiO₂-based solar cell design using diverse plant pigments. – *Int. J. Hydrogen Energ.* **42**: 8576-8585, 2017.
- Voloshin R.A., Brady N.G., Zharmukhamedov S.K. *et al.*: Influence of osmolytes on the stability of thylakoid-based dye-sensitized solar cells. – *Int. J. Energy Res.* **43**: 8878-8889, 2019.
- Voloshin R.A., Kreslavski V.D., Zharmukhamedov S.K. *et al.*: Photoelectrochemical cells based on photosynthetic systems: a review. – *Biofuel Res. J.* **2**: 227-235, 2015.
- Voloshin R.A., Rodionova M.V., Zharmukhamedov S.K. *et al.*: Components of natural photosynthetic apparatus in solar cells. – In: Najafpour M.M. (ed.): *Applied Photosynthesis – New Progress*. Pp. 161-188. InTech, Rijeka 2016.
- Walker D.A.: Polarographic measurement of oxygen. – In: Hall D.O., Scurlock J.M.O., Bolhár-Nordenkamp H.R. *et al.* (ed.): *Photosynthesis and Production in a Changing Environment*.

- Pp. 168-180. Springer, Dordrecht 1993.
- Walker D.A., Sivak M.N., Prinsley R.T., Cheesbrough J.K.: Simultaneous measurement of oscillations in oxygen evolution and chlorophyll *a* fluorescence in leaf pieces. – *Plant Physiol.* **73**: 542-549, 1983.
- Walsh F.C., Arenas L.F., Ponce de León C. *et al.*: The continued development of reticulated vitreous carbon as a versatile electrode material: Structure, properties and applications. – *Electrochim. Acta* **215**: 566-591, 2016.
- Wang P., Zhao F., Hartmann V. *et al.*: Reassessing the rationale behind herbicide biosensors: The case of a photosystem II/redox polymer-based bioelectrodes. – *Bioelectrochemistry* **136**: 107597, 2020.
- Wang W.-Q., Chapman D.J., Barber J.: Inhibition of water splitting increases the susceptibility of photosystem II to photoinhibition. – *Plant Physiol.* **99**: 16-20, 1992.
- Weijermars R., Taylor P., Bahn O. *et al.*: Review of models and actors in energy mix optimization – can leader visions and decisions align with optimum model strategies for our future energy systems? – *Energy Strategy Rev.* **1**: 5-18, 2012.
- Wey L.T., Bombelli P., Chen X. *et al.*: The development of biophotovoltaic systems for power generation and biological analysis. – *ChemElectroChem* **6**: 5375-5386, 2019.
- Wiederrecht G.P., Seibert M., Govindjee, Wasielewski M.R.: Femtosecond photodichroism studies of isolated photosystem II reaction centers. – *P. Natl. Acad. Sci. USA* **91**: 8999-9003, 1994.
- Xuan M., Li J.: Photosystem II-based biomimetic assembly for enhanced photosynthesis. – *Natl. Sci. Rev.* **8**: nwab051, 2021.
- Yehezkeli O., Bedford N.M., Park E. *et al.*: Semiconductor-based, solar-driven photochemical cells for fuel generation from carbon dioxide in aqueous solutions. – *ChemSusChem* **9**: 3188-3195, 2016.
- Yehezkeli O., Tel-Vered R., Michaeli D. *et al.*: Photosystem I (PSI)/Photosystem II (PSII)-based photo-bioelectrochemical cells revealing directional generation of photocurrents. – *Small* **9**: 2970-2978, 2013.
- Yehezkeli O., Tel-Vered R., Michaeli D. *et al.*: Photosynthetic reaction center-functionalized electrodes for photo-bioelectrochemical cells. – *Photosynth. Res.* **120**: 71-85, 2014.
- Yu D., Wang M., Zhu G. *et al.*: Enhanced photocurrent production by bio-dyes of photosynthetic macromolecules on designed TiO₂ film. – *Sci. Rep.-UK* **5**: 9375, 2015.
- Zaspa A.A., Vitukhnovskaya L.A., Mamedova A.M. *et al.*: Photovoltage generation by photosystem II core complexes immobilized onto a Millipore filter on an indium tin oxide electrode. – *J. Bioenerg. Biomembr.* **52**: 495-504, 2020.
- Zhang J.Z., Reisner E.: Advancing photosystem II photoelectrochemistry for semi-artificial photosynthesis. – *Nat. Rev. Chem.* **4**: 6-21, 2020.
- Zhang J.Z., Sokol K.P., Paul N. *et al.*: Competing charge transfer pathways at the photosystem II-electrode interface. – *Nat. Chem. Biol.* **12**: 1046-1052, 2016.