

# Psychometric properties of the Farsi version of modified Multidimensional Sexual Self-concept Questionnaire

Teyebe Ziaei<sup>1</sup>, Effat Merghati Khoei<sup>2</sup>, Mehrdad Salehi<sup>3</sup>, Ziba Farajzadegan<sup>4</sup>

## ABSTRACT

**Background:** The awareness regarding the contribution of sexual self-concept to healthy sexual well-being is on a rise. The Multidimensional Sexual Self-concept Questionnaire (MSSCQ) was developed to assess the 20 aspects related to sexual self-concept and has been widely applied in Western societies. The adequacy of its application in Iran has not been determined in order to guaranty its reliability and validity. An attempt was made here to interpret this questionnaire in Farsi and adopt it in Iran with respect to psychometric properties of the native youth.

**Materials and Methods:** A cross-sectional design was employed and 352 couples were recruited from a premarital consulting center in Isfahan, Iran on a random basis. The MSSCQ was translated into Farsi and back-translated by four bilingual scholars. Face and content validity of the questionnaire was determined. Internal consistency was evaluated by applying Cronbach's alpha. Pearson correlation coefficient was employed. The adopted model was tested through confirmatory factor analysis using SPSS-AMOS software (version 16).

**Results:** The mean age of couples was 25.68 years (women 23.92 ± 2.92 years and men 27.44 ± 3.14 years). The obtained Cronbach's alpha was 0.88. Twenty-two items with an impact score below 1.5 and content validity index <0.70 were omitted. Pearson correlation showed positive and negative correlations among the dimensions. Sexual anxiety, fear of sex, and sexual depression had negative correlation with the other dimensions ( $r = -0.36$ ,  $r = -0.43$ ,  $r = -0.32$ , respectively). The model exhibited adequate fitness:  $\chi^2/df = 4.95$ , goodness-of-fit index = 0.95, adjusted goodness-of-fit index = 0.91, normed fit index = 0.94, comparative fit index = 0.95, and root mean square error of approximation = 0.07.

**Conclusion:** The Farsi version of MSSCQ with 78 items is valuable and reliable to be applied on the youth in Isfahan. This questionnaire was verified under two main categories through confirmatory factor analysis: negative sexual self-concept and positive sexual self-concept.

**Key words:** Couples, Farsi, Iran, MSSCQ, psychometric, sexual self-concept

## INTRODUCTION

Sexual self-concept (SSC) is what a person realizes of his/her sexual desires and tendencies that are formed during the socio-emotional growth process accompanied with the sexual script. This emotional

phenomenon helps the person to gain awareness, acquire identity, and for self-evaluation regarding her/his sexual life.<sup>[1]</sup> It is vastly observed that the MSSCQ accompanies a person's sexual behavior. Snell *et al.* (1992) and Wiederman *et al.* (1993) reported that measuring/rating the sexual esteem, sexual depression, and sexual preoccupation can predict the sexual behavior and attitudes among both the genders.<sup>[2,3]</sup> In the studies conducted by Snell *et al.* in 1991, it was observed that the sexual consciousness and sexual assertiveness are related to satisfaction and sexual behaviors among the persons involved.<sup>[4]</sup> In this respect, many tools are introduced in order to evaluate the MSSCQ, such as: Sexual Awareness Questionnaire, Sexuality Scale (SS), Multidimensional Sexuality Questionnaire (MSQ), and Multidimensional Sexual Self-concept Questionnaire (MSSCQ).<sup>[5-7]</sup>

The MSSCQ, developed in 1995, is one of the most practical and mostly applied tools in measuring both genders' inclinations regarding their sexuality in psychological realms, inspired by Sexual Awareness Questionnaire and SS. The

<sup>1</sup>Department of Midwifery and Reproductive Health, Faculty of Nursing and Midwifery, Isfahan University of Medical Sciences, Isfahan, Iran, <sup>2</sup>Department of Health Education and Health Promotion, School of Public Health, Tehran University of Medical Sciences, Tehran, Iran, <sup>3</sup>Department of Psychiatry, Isfahan University of Medical Sciences, Isfahan, Iran, <sup>4</sup>Department of Community Medicine, Isfahan University of Medical Sciences, Isfahan, Iran

**Address for correspondence:** Dr. Effat Merghati Khoei, School of Public Health, Health Education and Health Promotion Division Risk Behavior Research Centers, Iranian National Center of Addiction Studies (INCAS) Brian and Spinal Injury Research Center (BASIR) Tehran University of Medical Sciences (TUMS), Argantin Campus No 52, Alvand St. Arjantin Sq, Tehran, Iran. E-mail: effat\_mer@tums.ac.ir

test group in Snell's study was composed of 504 psychology major students at Midwestern University in the age range of 18-25 years (321 women, 182 men, and 1 unknown sex).

The questionnaire contains 100 items in 20 dimensions, that is 5 items per dimension, covering the cognitive (sexual self-schemata), emotional (sexual depression), and motivation (sexual motivation) aspects. The Cronbach's alpha coefficient range is between 72 and 94%. The validity is verified through evaluating the questionnaires' content correlation with contraceptive use behaviors and beliefs, sexual behavior and attitudes, adult romantic attachment tendencies, contributions and benefits that are associated with their sexual relationships, and initial sexual experience by canonical correlation test.<sup>[6,7]</sup>

Although the tools that evaluate different dimensions of sexuality are sensitive and valid, the intermingling of sexual behaviors of any given society's culture makes it difficult to apply them in studies regarding the sexual behaviors and identify the problems thereof.

Studying sexual behaviors using non-community driven tools would be far more challenging in conservative societies such as Iran. Although theorists in the field of sociology accepted, identity, cognition, tendency, intelligence regarding sexual behaviors are formed and experienced in the growth and development process in both the genders before marriage.<sup>[8]</sup>

In these types of societies where sexual experiences are interpreted in the realm of marriage only, discussions on pre-marriage sexual behavior are not accepted, especially by the parents and the religious leaders.<sup>[9]</sup>

Iran is one of the societies where the sexual behaviors are revealed after the formal marriage contract is executed.<sup>[10]</sup> The restrictions imposed by the ethical norms regarding studies on the issue lead to having a limited portion of the society, the marriage age group, and this decreases the span of the field where related studies could be conducted. Most studies conducted in such societies focus on the medical or health aspects such as sexual disorder, sexual satisfaction, and/or risky sexual behaviors.<sup>[10,11]</sup>

If we assume that in societies like Iran, both the genders prolong their sexual experiences till marriage, then it seems that the sexual issues play an important role in mate selection. Despite the importance of the issue, very few sources are available in this field in Iran. Noohi *et al.* (2007) conducted a study on determining the awareness level and attitude among the couples that visited the marriage consulting center regarding right approach to sexual affairs in Tehran. They used a researcher-designed questionnaire

as the tool that evolved around Cronbach's alpha alone.<sup>[12]</sup> In the study conducted by Rahmani *et al.* (2009), the theme was the evaluation between sexual satisfaction and marital satisfaction among the married couples. This article relied mainly on the tools used in studies published in the Western societies.<sup>[13]</sup> A review on the conducted studies in Iran indicate that in the scientific research group, the nature of the issue is limited to and focused on the sexual functionality but not the structural fundamental perception of sexual identity formation among the subjects, i.e. the SSC.

The restricted nature of studying the complicated issues of sexology on one hand and lack of measuring tools of the variables involved in the sexual conception on the other makes interpretation of the MSSCQ necessary in order to make it fit the native mentality of the youth of Iran.

## MATERIALS AND METHODS

This cross-sectional study was conducted in 2011, based on a permission issued by the Ethical-Scientific Committee for the purpose of verifying the credibility of the tool applied at the only pre-marriage consulting and test center named Yas in the city of Isfahan. This center provides services like marriage-related medical tests and special pre-marriage training classes.

To enroll in this study, participants must be 18-35 years old, have a high school diploma and higher degrees, planning to get married or already married within the last 5 years. They should not have any psychological problems, be divorced or pregnant.

Systematic random sampling method was adopted in the following process. In forming the first group, the marital volunteer couples were selected based on the daily registered forms. In order to control the inconsistency regarding the entries in the study, the quota per day was fixed at 50% of enrolled couples. Everyday 25 couples were selected among the 50 registered ones. The sample range,  $K = 2$ , was used to randomly select candidates from the eligible list obtained by dividing the total of the list into the determined sample range. For example, the first candidate is selected from the list on a random basis. Afterward, the rest of the candidates are selected by adding  $K$  to the number of the previous selected member.<sup>[14]</sup>

At the end of consulting sessions, the selected participants were asked to gather in a hall. The researcher explained the necessities and allowed a few minutes for the couples to consult and make a decision.

In cases where couples were willing to participate in this study, they were asked to read, sign, and print their names

on an informed consent sheet and then they received the questionnaire. All participants were guaranteed complete anonymity and confidentiality. Participants were first given instructions in a general group format. They were asked to sit within two-arms' length from one another to refrain from talking during the session. The researcher was present to clear any ambiguity regarding the questions. The answering time range was within 45-60 min.

To form the second group, the couples that had previous records in the same center recorded within the last 5 years of their marriage were selected. The test group consisted of annual proportion of total married couples. In order to determine K for this phase, in each one of the 5 years, the desired number was divided into total number of the eligible married couples. The first random sample number was the first digit from the right side of a bill serial number, i.e. in 999378, number 8 was the first. Then, K was added to 8, and the second person, i.e. number 8 + K, on the list was selected and this pattern went on.<sup>[14]</sup>

After name selection, the necessary explanations were transmitted to the subjects on the phone, and upon agreement, the couples were invited to attend a meeting at Shahid Beheshti Hospital's conference room. Upon agreement, they were asked to read, sign, and print their names on an informed consent sheet; then they received the questionnaire and filled it in the same meeting session in accordance with the procedure followed for the first group.

A total of 395 couples from the two groups entered the study process. After checking the questionnaires, only 325 couples met the conditions to be the subject of analysis. The reason of exclusion was failure to complete the questionnaire (more than 10% missing). We aimed to collect data from both man and woman as a couple, therefore, we excluded those couples who only one of them filled of the questionnaire.

The MSSCQ designed by Snell in 1995 is a self-reporting objective tool used to measure 20 psychological dimensions regarding human sexuality. Here 100 expressive answers are scored based on Likert's scale, from 0 (it is not true about me) to 4 (it is completely true about me). Here, six expressions are reversely scored. The measurement is not based on the total scores, but the total scores of every dimension.

The SSC dimensions include: anxiety, self-efficacy, consciousness, motivation to avoid risky sex, chance/luck sexual control, preoccupation, assertiveness, optimism, sexual problem self-blame, monitoring, motivation, problem management, sexual esteem, satisfaction, power — other sexual control, self-schemata, fear of sex, problems' prevention, depression, and internal sexual control.<sup>[5]</sup>

For the translation of MSSCQ, written permission was obtained from Prof. Snell. Four translators, involved in this field, proficient in both English and Farsi languages were selected. Two translators did the English to Farsi translations and the other two back-translated the questionnaire. Next, a group of 13 experts involved in this field, such as family psychologist, reproductive health expertise, psychiatric nurse, and translators, assessed the questionnaire's content.<sup>[15-17]</sup> The final approved version of English was sent to the designer for verification of the modified questionnaire. The project began after his approval was received. The face and content validity was obtained by the experts in the field and the participants. The reliability was obtained through Cronbach's alpha coefficient. The compiled data were analyzed using SPSS 16 software, descriptive tests such as *t*-test and the Pearson correlation coefficient.

Exploratory factor analysis on the MSSCQ for reduction of dimensions' numbers and determining specific dimensions was conducted on the final Farsi questionnaire with 18 dimensions. The number of factors was determined based on Eigen Value > 1. Varimax rotation was applied in order to determine the independent dimensions. The results of functional pattern are described in accordance with factorial loads  $\geq 0.5$  and  $\leq -0.5$ . Kaiser-Meyer-Olkin (KMO) and Bartlett's tests were applied to evaluate the connection intensity between the variables and confirm the factorial analysis. The positive and negative SSC was tested through SPSS-AMOS software. The acceptable criteria for the model verification were obtained by the expressions Normed Chi — Square  $\chi^2/df \leq 5$ , Root Mean Squared Error of Approximation (RMSEA)  $\leq 0.08$ , Goodness-of-Fit Index (GFI), Adjusted Goodness-of-Fit Index (AGFI), Comparative Fit Index (CFI), and Normed Fit Index (NFI)  $\geq 0.90$ .<sup>[18,19]</sup>

## RESULTS

### The validation of the tools and pilot test

In order to determine the face validity, 13 experts in psychology, family counselor, reproductive health expertise, psychiatric nurse, and 30 couples with the test group standards and characteristics were asked to control the questionnaire regarding its flow, easy comprehension, grammar, writing style, and content, and then expressed their opinions on it. The ambiguous items were controlled and revised by two experts in the field.<sup>[17,20-23]</sup>

The same 30 couples were involved in evaluating the quantitative face and content validity of the questionnaire through applying item impact score.

The items with impact score less than 1.5 were not suitable for analyses and were eliminated (11 items that are: 5, 10,

15, 19, 25, 39, 45, 55, 65, 75, and 90).<sup>[24-26]</sup>

Impact Score = Frequency (%) × Importance

The 13 experts mentioned above were involved in the Content Validity Index (CVI) calculation. Items with less than 0.70 score were eliminated (11 items that are: 5, 7, 8, 9, 10, 11, 12, 32, 33, 42, and 75).<sup>[22]</sup>

$$CVI = \frac{\text{Number of raters giving a rate of "3" or "4"}}{\text{Total number of raters}}$$

Every dimension here consists of five items; in case three or more items do not fit in a dimension, they are eliminated.<sup>[27]</sup> Consequently, the final form of this questionnaire consists of 18 dimensions with 78 items. The internal consistency of the Farsi version of the questionnaire was evaluated through Cronbach's alpha coefficient. At the pilot test, 40 couples that corresponded to the main specifications were given the opportunity to complete the finalized questionnaire. The Cronbach's alpha coefficient for the questionnaire at this stage was 0.89.

### The main phase

The average mean age of the couples was 25.68 years (23.92 ± 2.92 years for women and 27.44 ± 3.14 years for men). The age difference mean among the couples was 3.54, where 88.6% of husbands were older than their wives. Educational status revealed that 60% of women were college students or had BA or BS; 64% of the men had below and above BA or BS. Most the women (75.3%) were homemakers and most of the men (55.3%) were state or private sector employees.

The Cronbach's alpha coefficient for the questionnaire as a whole was 0.88 and for the dimensions varied between 0.41 and 0.87. The least Cronbach's alpha coefficient was related to sexual optimism and the highest was related to sexual preoccupation.

The internal correlation in every dimension was evaluated by Pearson test. The results indicated that there existed a correlation among items and the total score of that dimension. For instance, for sexual anxiety, the correlation rate was between 0.74 and 0.83, and for sexual self-efficacy, it was between 0.57 and 0.81. The Pearson test determines the positive and negative correlation among the dimensions, and showed that sexual anxiety, fear of sex, and sexual depression had positive relation among them and negative correlation with the rest of the dimensions [Table 1].

Sexual anxiety, fear of sex, and sexual depression as negative dimensions have positive correlation with each other ( $r = 0.34$  to  $r = 0.63$ ) and they have negative correlation with the total score of other dimensions ( $r = -0.32$  to  $r = -0.43$ ).

### Exploratory factorial analysis

The exploratory factorial analysis results showed the KMO index as being 0.88 and the Bartlett's test less than 0.001 with a  $K^2$  5256.13. The three factors — positive, negative, and situational - extracted from Varimax rotation determined a total of 58% of the variances, 34.95, 12.86, and 10.32, respectively [Table 2].

### Verification of positive and negative SSC model

For the final model design, a three-stage process took place.

In the first stage, the negative SSC was designed and

**Table 1: Pearson correlation between negative dimensions and other dimensions**

	Sexual anxiety	Fear of sex	Sexual depression	Other dimensions
Sexual anxiety	1	0.634**	0.566**	-0.365**
Fear of sex		1	0.348**	-0.432**
Sexual depression			1	-0.327**
Other dimensions				1

\*\*Correlation sign at the 0.01 level (two-tailed) for all other dimensions included sexual self-efficacy, sexual consciousness, motivation to avoid risky sex, sexual preoccupation, sexual assertiveness, sexual optimism, sexual problem self-blame, sexual monitoring, sexual motivation, sexual problem management, sexual esteem, sexual satisfaction, sexual self-schemata, sexual problem prevention, and sexual internal control

**Table 2: Rotated component matrix of sexual self-concept dimensions**

Dimensions of sexual self-concept	Component of sexual self-concept		
	Positive SSC	Negative SCC	Situational SCC
Sexual anxiety		0.868	
Sexual self-efficacy	0.710		
Sexual consciousness	0.547		0.517
Motivation to avoid risky sex	0.525		
Sexual preoccupation			0.774
Sexual assertiveness			0.598
Sexual optimism			
Sexual monitoring		0.581	
Sexual motivation			0.804
Sexual problem management	0.724		
Sexual esteem	0.664		
Sexual satisfaction	0.518		
Sexual self-schemata			0.527
Fear of sex		0.620	
Sexual problem prevention	0.798		
Sexual depression		0.712	
Internal sexual control	0.740		

Extraction method: Principal component analysis  
Rotation method: Varimax with Kaiser normalization  
Rotation converged in five iterations



evaluated by AMOS software and failed. Afterward, the common model modification indexes were applied and finally the negative model of SSC was verified through  $\chi^2/df = 3.38$ , RMSEA = 0.058, AGFI = 0.97, CFI = 0.99, GFI = 0.99, and NFI = 0.99.

In the second stage, the same procedure was adopted for positive model of SSC which was verified through  $\chi^2/df = 3.36$ , RMSEA = 0.05, AGFI = 0.95, CFI = 0.98, GFI = 0.98, and NFI = 0.97.

In the third stage, the same procedure was adopted for combined (positive and negative SSC) model of SSC which was verified through  $\chi^2/df = 4.95$ , RMSEA = 0.07, AGFI = 0.91, CFI = 0.95, GFI = 0.95, and NFI = 0.94 [Figure 1].

### DISCUSSION

Snell's MSSCQ (1995) is one of the tools that measure the SSCs in different dimensions. Based on the findings of this study, Cronbach's alpha coefficient was 0.88 for the whole questionnaire and 0.41-0.87 for the dimensions, while the least internal correlation in Snell's study was 0.72.<sup>[5]</sup>

The available statistical difference between Snell's (1995) results and the results of this study could be explained as follows: in order for the SSC to be formed, the existence of training grounds for sex education from childhood to senescence is of necessity; therefore, in social step-ups like Iran where the comprehensive sexual education programs are nonexistent and the adults face the issue only through marriage,<sup>[28]</sup> it is obvious that lack of knowledge about the sexology and its termini, let alone the sexual self-identity. This lack of knowledge regarding

the sexual issue would produce different effects even if the best designed scientific questionnaires are employed in such cultures. Here, the cultural norms would have their effect on the guidance and state of mind regarding sexual behavior among the members of the society. In an evaluation regarding sexual knowledge, attitude, and practice of Asian and European women in Canada (2005), the latter were more aware and educated in addition to having sexual experience, with respect to items like liberal attitude to sexuality, desire, excitement, and pleasure in comparison with the Asian women.<sup>[29]</sup> The prevailing socio-cultural situations do influence the SSC; therefore, the results obtained even from the best designed questionnaires might differ. This is the reason that Rostosky *et al.* (2008) obtained different coefficients in their study. They selected and combined sexual anxiety, optimism, sexual esteem, and sexual monitoring from the 20 dimensions and applied them as sexual esteem and sexual anxiety. The Alpha coefficients for these two newly developed dimensions are 0.90 and 0.88, respectively.<sup>[30]</sup> In this study, the inter-dimensional correlation among the dimensions and explanatory factorial analysis indicate that a few small dimensions could generate sizable dimensions labeled as positive, negative, and situational. Here, situational dimension refers to occasional negative or positive contribution of SSC.

Rostosky (2008), in his categorization of SSC dimensions, refers to two sizable positive and negative dimensions and wrote, "we evaluated for positive and negative dimensions regarding sexual self-concept from Snell's questionnaire."<sup>[30]</sup> In his article, he does not explain the rationale behind using the terms positive and negative dimensions.

In this study, the nature of the questions that influence the sizable positive and negative dimensions is justified.

The negative dimensions naturally indicate sexual anxiety, fear of sex, and sexual depression, which refer to sexual life. Here, sexual anxiety ascribes tension, discomfort, and negative evaluation of sexual life; fear of sex refers to the fear of sexual involvement with the opposite sex; depression has to do with the negative feelings about of sexual life.<sup>[5]</sup>

The positive dimensions indicate sexual behaviors, motivation, and emotions which include sexual optimism, sexual esteem, and sexual problem management. Here, sexual optimism refers to arousal, enjoyment, and gaining superiority in a specific sexual affair.<sup>[31]</sup> Sexual esteem is valued as positive evaluation of engaging in healthy sexual relationships through pleasurable and satisfactory manners. Sexual problem

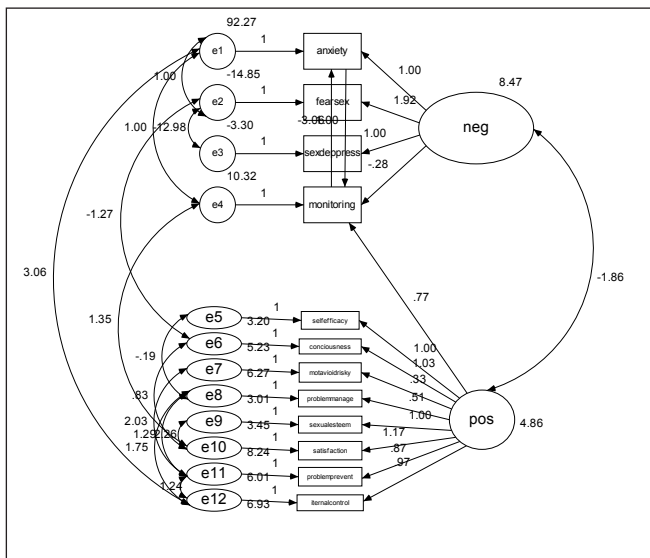

Figure 1: Positive and negative sexual self-concept model

management is accompanied with control and the belief that sexual problems could be solved with proper behavioral management.<sup>[5]</sup>

Hensel *et al.* (2010) refer to this point in a study regarding teenage SSC and behavior. In their study, an inverse relation was observed with respect to positive and negative dimensions in a sense that an increase in sexual anxiety is accompanied with a decrease in sexual esteem ( $r = -0.342$ ,  $P < 0.006$ ).<sup>[32]</sup>

O'Sullivan *et al.* (2006) are of the opinion that positive and negative aspects of SSC refer to excitement, arousal, and desire in their positive sense and sexual anxiety in their negative sense.<sup>[1]</sup>

Andersen *et al.* (1994, 1999) conducted a study on sexual self-schema on men and women, regarding the positive and negative aspects of this self-schema. They found that the women with negative schema reported more anxiety and resistance than excitement and arousal, in comparison with the women with positive schema.<sup>[33,34]</sup>

Despite the conceptual theories regarding SSC formation that evolved in the 80s, there are limited studies to support the multidimensional self-concepts and the correlation between them;<sup>[35]</sup> therefore, to enrich and better categorize MSSC, sizable positive and negative dimensions are subject to further studies.

## CONCLUSION

Based on the findings in this study, it could be claimed that the Farsi version of MSSCQ with 78 items in 18 dimensions is categorized into two positive and negative sizable dimensions that could be applied, while more studies must be conducted for its applicability with respect to the socio-cultural influences in the given societies.

Overall, the findings of this research show that the Farsi version of MSSCQ with 18 dimensions including 78 items is valuable and reliable to be applied on the youth in Isfahan. This questionnaire was verified under two main categories through confirmatory factor analysis: negative SSC (sexual anxiety, fear of sex, and sexual depression) and positive SSC (sexual self-efficiency, sexual consciousness, and motivation to avoid risky sex).

## ACKNOWLEDGMENTS

This research was funded by the Isfahan University of Medical Sciences (registered number: 389465). Our sincerest thanks go to Professor William E. Snell who generously gave us permission to use SSCS instrument. Thanks also go to

Professor Bagher ssanaei Zaker for his invaluable input. We thank the translators, and the specialists who assisted us in the study protocol. Our special thanks go to the couples who participated in the study. We also appreciate the support received from Yas premarital laboratory and counseling staffs during the study.

## REFERENCES

- O'Sullivan L, Meyer-Bahlburg H, McKeague I. The development of the sexual self-concept inventory for early adolescent girls. *Psychology of Women Quarterly*. 2006;30(2):139-49.
- Snell W, Fisher T, Schuh T. Reliability and validity of the Sexuality Scale: A measure of sexual-esteem, sexual-depression, and sexual-preoccupation. *Journal of Sex Research*. 1992;29(2):261-73.
- Wiederman MW, Allgeier ER. The Measurement of Sexual-Esteem: Investigation of Snell and Papini's (1989) Sexuality Scale. *Journal of Research in Personality*. 1993;27(1):88-102.
- Snell W, Fisher T, Miller R. Development of the Sexual Awareness Questionnaire: Components, reliability, and validity. *Sexual Abuse: A Journal of Research and Treatment*. 1991;4(1):65-92.
- Snell J, WE. The multidimensional sexual self-concept questionnaire 1998.
- Snell Jr WE. Measuring multiple aspects of the sexual self-concept: The Multidimensional Sexual Self-Concept Questionnaire. In W. E. Snell, Jr. (Ed.), *New directions in the psychology of human sexuality: Research and theory*. 2001;ch 17.
- Snell Jr WE, Fisher TD, Walters AS. *New Directions in the Psychology of Human Sexuality: Research and Theory Chapter 7: The Multidimensional Sexuality Questionnaire: An Objective Self-Report Measure of Psychological Tendencies*. 2001.
- Rambaree K. Youth Culture and Net Culture: Online Social Practices: [lhttp://www.igi-global.com/chapter/young-people-cybersex-sexually-conservative/50699](http://www.igi-global.com/chapter/young-people-cybersex-sexually-conservative/50699); 2011.
- Gagnon J, Simon W. *Sexual conduct: The social sources of human sexuality*: Aldine; 2005.
- Farahani FKA, Cleland J, Mehryar AH. Associations Between Family Factors and Premarital Heterosexual Relationships Among Female College Students in Tehran. *International perspectives on sexual and reproductive health*. 2011;37(1):30.
- Haeri S. *Law of desire: Temporary marriage in Iran*. London: I. B. Tauris; 1989.
- Noohi S, Azar M, Shafieikonjani A, Tajic A. Agahi va negaresh zozjhaye morajee konnande be marakeze moshavere ezdevaj dar morede ravabete jensi sahih. *Hayat*. 2007;13(3):77-83 persian.
- Rahmani A, Merghati Khoei E, Gholi L. Sexual Satisfaction and its Relation to Marital Happiness in Iranians. *Iranian J Publ Health*. 2009;38(4):77-82.
- Mokhtari-amirmajdi G. *Sampling of Populations: Methods and Applications(Translated to Persian): Statistical reserch centre(Pazhoheshkadeh amar)*; 2002. Available from: <http://www.src.ac.ir>.
- Brislin R. Back-translation for cross-cultural research. *Journal of Cross-Cultural Psychology*. [abstract]. 1970;1(3):185-216.
- Brislin R. Translation and content analysis of oral and written material. *Handbook of cross-cultural psychology*. 1980;2:389-444.
- Willgerodt MA, Kataoka-Yahiro M, Kim E, Ceria C. Issues of Instrument Translation in Research on Asian Immigrant Populations. *Journal of Professional Nursing*. 2005;21(4):231-9.

18. Hu L-t, Bentler PM. Cutoff criteria for fit indexes in covariance structure analysis: Conventional criteria versus new alternatives. *Structural Equation Modeling: A Multidisciplinary Journal*. 1999;6(1):1-55.
19. Pai H-C, Lee S. Sexual self-concept as influencing intended sexual health behaviour of young adolescent Taiwanese girls. *Journal of Clinical Nursing*. 2012;21(13-14):1988-97.
20. Doward L, Mead M, Tharsen H. Requirement for quality of life instrument in clinical research *Value Health*. 2004;7:134-9.
21. Malekafzali H, Majdzadeh S, Fotoohi A, Tavakoli S. *Ravesh shenasi pazhooheshhaye karbordi dar oloome pezheshki*. Tehran: Tehran medical sciences university publisher; 2004.
22. Polite D, Beck C. *Nursing Research: Generating and Assessing Evidence for Nursing Practice*. Philadelphia: Lippincott Williams & Wilkins. 2008;8.
23. Seif A. *Andazegiri, sanjesh va arzeshyabi amoozeshi (Farsi)*. Tehran: Nashr; 2004.
24. Broder HL, McGrath C, Cisneros GJ. Questionnaire development: face validity and item impact testing of the Child Oral Health Impact Profile. *Community dentistry and oral epidemiology*. 2007;35:8-19.
25. Hajizadeh E, Asghari M. *Statistical methods and analyses in health and biosciences a research methodological approach*. Tehran: Jahade Daneshgahi Publications(persian); 2011.
26. Vakili MM, Hidarnia AR, Niknami S. Development and Psychometrics of an Interpersonal Communication Skills Scale (A.S.M.A) among Zanjan Health Volunteers. *Journal of Nursing And Midwifery of Tehran University OF Medical Sciences(Hayet) (persian)*. 2012;18(1):5-19.
27. Suhr D, Greeley C. *Creating Scales from Questionnaires: PROC VARCLUS vs. Factor Analysis*. 2003.
28. Merghati khoei E. Socio-cultural Context and and Iranian women's sexual understanding. sydney: University of New south Wales; 2006.
29. Brotto LA, Chik HM, Ryder AG, Gorzalka BB, Seal BN. Acculturation and sexual function in Asian women. *Archives of Sexual Behavior*. 2005;34(6):613-26.
30. Rostosky S, Dekhtyar O, Cupp P, Anderman E. Sexual self-concept and sexual self-efficacy in adolescents: a possible clue to promoting sexual health? *Journal of Sex Research*. 2008.
31. Horne S, Zimmer-Gembeck MJ. The female sexual subjectivity inventory: Development and validation of a multidimensional inventory for late adolescents and emerging adults. *Psychology of Women Quarterly*. 2006;30(2):125-38.
32. Hensel DJ, Fortenberry JD, O'Sullivan LF, Orr DP. The developmental association of sexual self-concept with sexual behavior among adolescent women. *Journal of Adolescence*. 2010.
33. Andersen BL, Cyranowsk iM, Derek E. Men's Sexual Self-Schema. *Journal of Personality and Social Psychology*. 1999;76(4):645-61.
34. Andersen BL, Cyranowski JM. Women's sexual self-schema. *Journal of Personality and Social Psychology*. 1994;67(6):1079.
35. Ha MT, Marsh HW, Halse C, editors. *Educational and mental health implications of the multidimensional model of the self-concept for adolescent girls: comparison of clinical and non-clinical samples 2011: Australian Association for Research in Education*.

**How to cite this article:** Ziaei T, Khoei EM, Salehi M, Farajzadegan Z. Psychometric properties of the Farsi version of modified Multidimensional Sexual Self-concept Questionnaire. *Iranian J Nursing Midwifery Res* 2013;18:439-45.

**Source of Support:** Isfahan University of Medical Sciences (registered number: 389465), **Conflict of Interest:** None declared.