



A genetically engineered *Escherichia coli* that senses and degrades tetracycline antibiotic residue



Zepeng Mu^a, Zhuoning Zou^a, Ye Yang^a, Wenbo Wang^a, Yue Xu^a, Jianyi Huang^a, Ruiling Cai^a, Ye Liu^a, Yajin Mo^a, Boyi Wang^a, Yiqun Dang^a, Yongming Li^a, Yushan Liu^a, Yueren Jiang^a, Qingyang Tan^a, Xiaohong Liu^b, Cheng Hu^b, Hua Li^c, Sha Wei^c, Chunbo Lou^{d,e}, Yang Yu^{f,*}, Jianguyun Wang^{b,**}

^a University of Chinese Academy of Sciences Team for iGEM 2016, Beijing, 100049, China

^b Key Laboratory of RNA Biology, Institute of Biophysics, Chinese Academy of Sciences, Beijing, 100101, China

^c National Laboratory of Biomacromolecules, CAS Center for Biomacromolecules, Beijing, 100101, China

^d Key Laboratory of Microbial Physiological and Metabolic Engineering, Institute of Microbiology, Chinese Academy of Sciences, Beijing, 100101, China

^e College of Life Sciences, University of Chinese Academy of Sciences, Beijing, 100049, China

^f Tianjin Institute of Industrial Biotechnology, Chinese Academy of Sciences, Tianjin, 300308, China

ARTICLE INFO

Article history:

Received 24 December 2017

Received in revised form

25 April 2018

Accepted 14 May 2018

Keywords:

TetX

Antibiotic residue

Toxin-antitoxin system

Kill-switch

ABSTRACT

Due to the abuse of antibiotics, antibiotic residues can be detected in both natural environment and various industrial products, posing threat to the environment and human health. Here we describe the design and implementation of an engineered *Escherichia coli* capable of degrading tetracycline (Tc)-one of the commonly used antibiotics once on humans and now on poultry, cattle and fisheries. A Tc-degrading enzyme, TetX, from the obligate anaerobe *Bacteroides fragilis* was cloned and recombinantly expressed in *E. coli* and fully characterized, including its K_m and k_{cat} value. We quantitatively evaluated its activity both *in vitro* and *in vivo* by UV-Vis spectrometer and LC-MS. Moreover, we used a tetracycline inducible amplification circuit including T7 RNA polymerase and its specific promoter P_{T7} to enhance the expression level of TetX, and studied the dose-response of TetX under different inducer concentrations. Since the deployment of genetically modified organisms (GMOs) outside laboratory brings about safety concerns, it is necessary to explore the possibility of integrating a kill-switch. Toxin-Antitoxin (TA) systems were used to construct a mutually dependent host-plasmid platform and biocontainment systems in various academic and industrious situations. We selected nine TA systems from various bacteria strains and measured the toxicity of toxins (T) and the detoxifying activity of cognate antitoxins (A) to validate their potential to be used to build a kill-switch. These results prove the possibility of using engineered microorganisms to tackle antibiotic residues in environment efficiently and safely.

© 2018 Production and hosting by Elsevier B.V. on behalf of KeAi Communications Co. This is an open access article under the CC BY-NC-ND license (<http://creativecommons.org/licenses/by-nc-nd/4.0/>).

1. Introduction

Antibiotics are widely used in hospitals, animal husbandry and aquaculture industry to prevent bacterial infections and to boost growth. As a result, antibiotics remain in meat products [1–5],

honey [5–14] and milk supplies throughout the world [15–20]. Waste water from above facilities is emitted into the environment [21] without proper treatment, thus leading to a large amount of environmental antibiotic residues. Many of the antibiotics are hard to be thoroughly decomposed in nature, and can be accumulated in the food chain [22], posing threat to human and animal health, and contribute to antimicrobial resistance [23,24].

At present a number of methods and test kits are readily available to detect antibiotic residues from various sources, including biochemical methods [13], chromatography [20,25], mass spectrum related technologies [5,7–10,12,14,18], as well as microbial screening [2,3,26]. However, strategies for direct degradation of antibiotic residues are scarce. Most strategies currently available

* Corresponding author. Current address: Institute for Synthetic Biosystem and Department of Biochemical Engineering, School of Chemistry and Chemical Engineering, Beijing Institute of Technology, Beijing, 100081 China.

** Corresponding author.

E-mail addresses: yang_yu@outlook.com (Y. Yu), jwang@ibp.ac.cn (J. Wang).

Peer review under responsibility of KeAi Communications Co., Ltd.

make use of chemical [27,28] or physical methods [29,30] with low specificity. As the use of antibiotics is unavoidable and hard to manage, it is imperative to develop methods to degrade antibiotic residues with high specificity and efficiency. Many antibiotics-degrading enzymes have been discovered and characterized, which are capable of degrading antibiotics with high efficiency and specificity [31]. Biological degradation of antibiotic residues provides a sustainable way to tackle this problem, with efficiency and safety problem yet to be solved in future studies.

To solve the problem of antibiotic residues, we constructed an engineered antibiotic degrading bacterium with the tools of synthetic biology that is expected to function in a given site like waste water treatment plants (WWTPs) or antibiotic factories. We chose tetracycline as an example in our design because it is one of the most abundant families of antibiotic used, the concentration of which ranges from 3.6–219.8 ng/L in water samples and 2.4–100 µg/kg in sediment samples [32], and the concentration of tetracyclines in feedlot wastewater lagoons even reaches 294.0–376.1 µg/L [33]. Meanwhile, our system can be applied to various types of antibiotic through proper selection of antibiotic degrading enzymes.

Lying in the core of our system is the tetracycline degrading enzyme TetX. TetX monooxygenase is a naturally-existing tetracycline enzyme from *Bacteroides fragilis* coded by gene tet(X) [34]. Unlike other tetracycline resistant enzymes which either offer direct protection to ribosomes (TetM [35,36], TetO [36–38], TetS [36]) or pump tetracycline molecules out of bacteria cells (TetA, TetB [39–41], etc.). TetX as a tetracycline modification enzyme that has a wide substrate spectrum including tigecycline [42]. It has the ability to catalyze regio-specific hydroxylation at carbon 11a of tetracycline antibiotic molecules in the presence of FAD, NADPH, Mg²⁺, and O₂. The resultant product 11a-hydroxy-tetracycline has no antibiotic activity and spontaneously decomposes rapidly into substances that are not easily identifiable in solutions of pH greater than 1 (Supplementary Fig. S1) [34]. TetX was cloned and recombinantly expressed in *E. coli* and fully characterized, including its K_m and k_{cat} value. Furthermore, we constructed a genetic circuit to overexpress TetX in response to the concentration of tetracycline and evaluated its efficiency.

A biocontainment system is necessary for using engineered bacteria outside laboratory. Biocontainment systems have been developed using several strategies, including auxotrophy [43,44], codon reassignment methods [45,46], the expression of toxic proteins [47,48], complex synthetic circuits [49], and the combination of several methods [50]. We chose to use toxin-antitoxin (TA) systems from bacteria, a widespread system where the product of antitoxin gene serves as the antidote for the protein toxin [60], as candidates for constructing a suicide module as a biocontainment system. We selected 9 toxin-antitoxin (TA) systems from various bacteria strains and measured the toxicity of toxins and the detoxifying activity of cognate antitoxins to validate their potentiality to be used to build a kill-switch. These results prove the possibility of using engineered microorganisms to tackle antibiotic residues in environment efficiently and safely.

2. Material and methods

2.1. Plasmids, bacterial strains and growth conditions

DNA encoding TetX was synthesized with codon optimized for *E. coli* expression, cloned to plasmid pET-22b(+) with a hexahistidine tag at the carbon terminal, and subsequently transformed to *E. coli* BL21(DE3) strain for protein expression and purification.

When constructing the amplification circuit, typical enzymatic

restriction digestion and ligation and 3A assembly [51] were used to assemble plasmids. Briefly, three distinct antibiotic resistance markers (3A) were used for upstream part, downstream part and destination vector. These parts were digested and ligated, after which antibiotic corresponding to the destination vector was used to select the desired clone. In this project, we first ligated a) the gene encoding TetX-GFP fusion protein with T7 promoter and terminator; b) T7 RNA polymerase with tetracycline inducible promoter and terminator. Then, a) and b) were concatenated and ligated to backbone pSB1C3. TetX-GFP fusion protein was produced by overlapping polymerase chain reaction. All plasmids were assembled, amplified and tested using *E. coli* strain DH5α (Transgene Biotech CD201). DNA sequences were cloned into backbone pSB1C3 with chloramphenicol resistance before measurement.

Toxin genes of TA system 133, 134, 1198, 1204, 6249 were amplified by PCR from genomic DNA of corresponding bacteria strains (see Table 2), and that of 5980, 4222, 5693, 5694 were commercially synthesized according to the codon preference in *E. coli*. Antitoxin genes of that of 134, 1198, 1204, 6249 were amplified by PCR from genomic DNA of corresponding bacteria strains. Toxin genes and antitoxin genes were cloned to a pSB3A5 derived cloning vector p_{Tet} and a pSB4C5 derived cloning vector P_{Tac}, respectively, by Golden Gate assembly method [52]. These constructs are subsequently used to validate the toxicity of toxins genes and the detoxifying effects of antitoxin genes.

Plasmids with toxin genes were separately transformed into *E. coli* strains Trans5α and TOP10 for characterization.

Bacteria were grown in LB broth or on LB agar plate with corresponding antibiotics at 37 °C, unless otherwise specified.

All the plasmids and host strains used in this experiment are listed in Table 1.

2.2. Protein expression and purification

TetX expression vector is derived from pET-22b(+), in order to use immobilized metal ion affinity chromatography (IMAC) to conduct histidine-tagged recombinant protein purification. TetX expression was induced by addition of 1 mM IPTG when OD₆₀₀ was

Table 1
Summary of plasmids and host strains used in this experiment.

	Plasmid Backbone	Promoter	Downstream Gene	Host Strain
Degradation system	pET-22b(+)	T ₇	tet(X)	BL21(DE3)
Amplification Circuit	pSB1C3	P _{Tet}	tet(X)-gfp	DH5α
	pSB1C3	P _{Tet}	T7 RNA polymerase	Trans5α
TA system Validation	pSB3A5	P _{con}	tetR	Trans5α
	pSB3A5	P _{Tet}	Toxins	Trans5α, TOP10
	pSB4C5	P _{Tac}	Antitoxins	Trans5α

Table 2
Toxin-antitoxin (TA) systems used in this experiment.

Source Species	TAs ID	Experiment Validated
<i>Bacillus subtilis</i>	134	Yes [59]
<i>Mycobacterium tuberculosis</i>	6249	No
<i>Mycobacterium tuberculosis</i>	133	No
<i>Photobacterium luminescens</i>	1198	No
<i>Photobacterium luminescens</i>	1204	No
<i>Salmonella enterica</i>	5980	No
<i>Sinorhizobium medicae</i> (plasmid pSMED01)	4222	No
<i>Leptospira biflexa</i>	5693	No
<i>Leptospira biflexa</i>	5694	No

about 0.8. The culture was incubated at 18 °C overnight before being harvested and purified by metal ion affinity chromatography with Ni²⁺-NTA (NiNTA) resin.

2.3. Spectrophotometric assay of tetracycline

TetX (2.3 μM) was added to a tetracycline solution (30 μM) in 10 mM Tris-HCl buffer, pH = 8.5. The reaction was initiated by addition of NADPH (200 μM). UV spectra were recorded every 2s for 200s on a Agilent 8453 spectrophotometer. Kinetic parameters were determined by the standard Michaelis-Menten equation:

$$V_o = k_{cat}[Et][S]/([S] + K_m)$$

2.4. Solid phase extraction for tetracycline

The HLB SPE column (Supel-Select SPE, SUPELCO) was washed with 5 mL ddH₂O for 2 times. 5 mL sample — the centrifuged M9 minimal culture medium — was loaded on to the HLB column. Use the plunger from a 2 mL disposable syringe to exert a positive pressure on to the column to elute the sample solution. Extracted droplets are reloaded on to the column and extracted for the second time. The HLB column was washed with ddH₂O for 2 times. Tetracycline was eluted with 1 mL Dimethylformamide (DMF).

2.5. LC-MS analysis for tetracycline

Waters LC-MS system was used to quantify the amount of tetracycline residues in samples extracted by SPE. MS is first performed to analyze the samples and specimens with *m/z* 455 is identified as tetracycline. LC is subsequently performed (running time: 12 min, seal wash period: 5 min, solvent A: 0.1% Trifluoroacetic acid (TFA) in MeOH solvent B: 0.1% Trifluoroacetic acid (TFA) in water, program: A/B: 5%/95% at 0 min and 2 min, 40%/60% at 2.10 min, 70%/30% at 8 min, 90%/10% at 8.10 min and 12 min). Tetracycline is expected to have a retention time of 6.72 min. Peak area is integrated and compared with standard samples as the relative amount of tetracycline.

2.6. Characterization of the amplification circuit

The measurement was done using BioTek Cytation 3 microplate detector and PerkinElmer ViewPlate-96 (6005181) microplate. Each well was filled with 147.5 μL LB containing chloramphenicol and tetracycline/anhydrotetracycline. 1.5 μL bacteria solution with an OD₆₀₀ of 1.0 was transferred to the corresponding well. The microplate was incubated at 37 °C with shaking rotor for 12 h in the microplate detector. The detector measured the fluorescence intensity and the OD₆₀₀ of each well every 10 min.

2.7. Characterization of the TA systems

Each TA system was validated by measuring growth curves of bacteria containing empty vector or plasmid with toxins. A single colony or 10 μL of frozen bacteria were used to inoculate 400 μL LB liquid medium with corresponding antibiotic and the culture was incubated at 37 °C for 12–14 h. The overnight culture was diluted using LB medium without aTc for 10 times. 150 μL of LB containing 1.7 μg/mL aTc was added to a 96-well microplate (costar 3599). Only the central 60 wells were used in order to prevent evaporation, and the surrounding 36 wells were filled with 150 μL of LB medium to buffer this effect. Add 1.5 μL of diluted bacteria medium to the wells, furthering diluting them by 100 times. Growth curves

were measured by BioTek Cytation™ 3 microplate spectrophotometer. The program was set as follows: Incubate at 37 °C for 10 h and shake linearly, during which the value of OD₆₀₀ was measured every 10 min. Each experiment was done in triplicate.

3. Results and discussion

3.1. TetX degrades tetracycline with high efficiency

TetX is a flavin-dependent monooxygenase capable of degrading tetracycline and its analogs. tet(X), the gene encodes TetX, was synthesized and cloned into pET-22b(+) with a C-terminal hexahistidine tag. TetX was expressed in *E. coli* and purified by metal affinity chromatography (Supplementary Fig. S2). Activity of TetX was tested *in vitro* by mixing the as-purified enzyme (2.3 μM) with NADPH (200 μM) and Tc (30 μM). Absorbance at 360 nm was monitored as it is the characteristic for Tc. By subtracting the absorbance of NADPH, we calculated the kinetic parameters of tetracycline modification to be K_m , 48.93 μM; k_{cat} , 0.21 s⁻¹; and k_{cat}/K_m , 4.293×10^3 M⁻¹ s⁻¹ (Supplementary Figs. S3–S5), which are similar to those observed TetX-mediated oxidation reactions of other tetracyclines, K_m , 54.0 ± 11.5 μM; k_{cat} , 0.32 ± 0.02 s⁻¹ [34,53]. Since the K_m of TetX is much higher than Tc concentrations in the environment, future engineering of the enzyme is needed to use it in treating environmental water.

To test whether TetX can degrade Tc *in vivo*, we cloned tet(X) into plasmid pET-22b(+) and tet(X)-gfp under P_{Tet} promoter into pSB1C3 plasmid backbone, and transformed the plasmids into *E. coli* BL21(DE3) and DH5α respectively. Gene transcription is turned on in absence of P_{Tet}'s repressor, TetR. After plasmid transformation, BL21(DE3) strain could survive up to 50 μg/mL of Tc with expression of TetX, and DH5α strain could survive up to 20 μg/mL of Tc with expression of TetX- GFP fusion protein (Fig. 1). Furthermore, the expression of TetX-GFP fusion protein leads to a 27% reduction of absorbance at 360 nm in M9 minimal culture medium after 6 h incubation, compared with control group (Supplementary Fig. S6). The aforementioned validation tests both indicate TetX and TetX-GFP fusion protein can actively reduce the concentration of Tc *in vivo*.

To further quantify the *in vivo* degradation efficiency of TetX, we extracted the Tc residues from *E. coli* after 19 h of incubation by solid-phase extraction. The concentrated tetracycline was resolved in dimethyl formamide for the analysis by LC-MS, which demonstrates that the tetracycline residues extracted from the culture medium with *E. coli* expressing TetX are reduced to 1.60% of that in control group without expression of TetX (Supplementary Fig. S7).

3.2. The tetracycline inducible amplification circuit increases the expression level of downstream gene

To increase expression level of TetX, we constructed an amplification circuit by introducing T7 RNA polymerase and its specific promoter P_{T7}, a strong promoter [54]. To implement the inducible transcription of TetX based on the concentration of Tc, we utilized a Tc inducible transcriptional repressor TetR and its operator, P_{Tet} [55] to regulate the expression of T7 RNA polymerase. TetX was fused with GFP to enable the visualization and quantification of the amount of protein by fluorescence (Fig. 2). Known for its high transcription activity, we expected that the expression level of TetX to be significantly higher under P_{T7} compared to the control design where TetX is controlled only by P_{Tet}.

As shown in Fig. 3, *E. coli* in the experiment group produces a larger amount of TetX-GFP (reflected by fluorescence intensity) than those in the control groups in the same period of time at different concentration of Tc (Fig. 3-(a), (c), (e)). Besides, when toxic

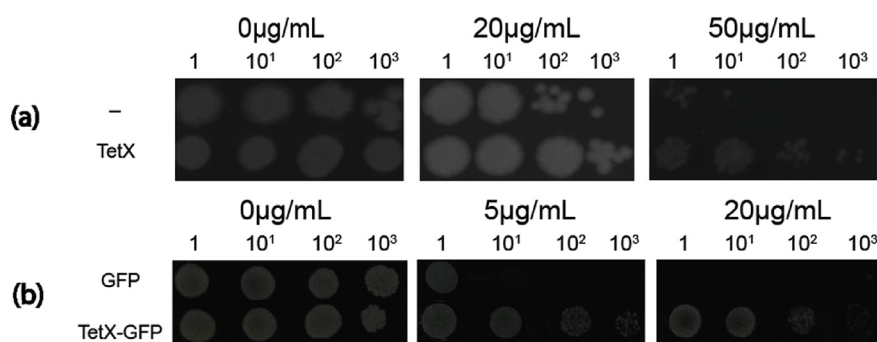

Fig. 1. Growth analysis of BL21(DE3) with or without TetX and DH5 α with or without TetX-GFP fusion protein. (a) culture of BL21(DE3) with empty pET-22b(+) plasmid (upper panel) or pET-22b(+)-tet(X) (lower panel) was diluted 1, 10, 100, 1000 fold and spotted on LB agar plate with 0, 20, 50 μ g/mL Tc. Expression of TetX in BL21(DE3) resists the bacteriostatic effect by modification and inactivation of tetracycline. (b) culture of DH5 α with pSB1C3- P_{Tet} -gfp plasmid (upper panel) or pSB1C3- P_{Tet} -tet(X)-gfp (lower panel) was diluted 1, 10, 100, 1000 fold and spotted on LB agar plate with 0, 5, 20 μ g/mL Tc. TetX and GFP fusion protein in DH5 α still maintains its activity for modification and inactivation of tetracycline.

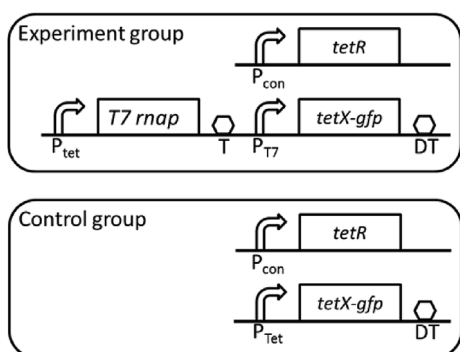

Fig. 2. T7 polymerase and T7 promoter are used to increase the enzyme expression. The tetracycline sensing protein is constitutively expressed, and specifically binds to P_{Tet} promoter to suppress the transcription of *T7 rnap*. T7 RNAP is a high activity DNA transcriptase recognizing P_{T7} promoter, to which *tetX-gfp* gene is downstream. P_{con} : a constantly-expressing promoter; P_{Tet} : tetracycline inducible promoter; *T7 rnap*: T7 RNA polymerase; P_{T7} : T7 RNA polymerase specific promoter; TetX-GFP: T: terminator; DT: double terminators.

Tc is added to the culture, *E. coli* in the experiment group grows better than those in the control group (Fig. 3-(b), (d), (f)), which suggests it degrades Tc so efficiently that its growth is less influenced by Tc's toxicity.

3.3. Toxins showed various levels of growth arrest in *E. coli* Trans5 α and TOP10

Toxins and antitoxins in Type II TA systems are both small proteins. The expression of toxin inhibits the growth of bacteria through interfering with essential biological processes like DNA synthesis [56] and mRNA stability [57], which can be sequestered by corresponding antitoxin through specific binding to the toxin protein. The interaction between a toxin and the cognate antitoxin makes them an ideal pair to be repurposed and fine-tuned. Although TA systems are prevalent in prokaryotes and their orthologs widely exist in different organisms, the effect on growth varies between closely related bacterial species and strains, making it necessary to screen a wide range of TA systems.

In an ideal suicide module, the toxicity of toxin should not only be sufficient to inhibit bacteria growth, but is also required to be effectively counter-balanced by cognate antitoxin. In addition, as toxin imposes a strong selective pressure on bacteria cells, mutations that occur in toxin gene could lead to its loss of function,

disrupting the action of the suicide module. Thus, TA systems suitable for building a suicide module are expected to have low mutation rate.

To identify fitting TA systems for constructing a suicide module in *E. coli*, we selected 9 TA systems from six different organisms to test their effects on bacteria growth (Table 2). TAs ID refers to the exclusive number assigned to each TA system in Toxin-Antitoxin Database (TADB) [58], and was used to denote different TA systems later in this study. Toxins and antitoxins would be denoted using T or A followed by their corresponding TAs ID later, such as T134 and A134. No TA systems were selected from *E. coli* to prevent interference of endogenous genes on the genome. Toxin genes were cloned to a pSB3A5 derived plasmid under the control of P_{Tet} promoter. We then measured the growth curves of *E. coli* Trans5 α or TOP10 strains containing either empty vector or plasmid with a toxin gene when fully induced with 1.7 μ g/mL of aTc at the beginning of incubation. As presented in Fig. 4-(a) and (b), T134, T1204, T6249 are toxic to both *E. coli* Trans5 α and TOP10 strains, inhibiting the growth of bacteria significantly when expressed. T4222 showed stronger growth inhibition in Trans5 α than in TOP10, and toxin T133, T1198, T5693, T5694, T5980 had no significant toxic activity in either strains (Supplementary Fig. S8).

3.4. Cognate antitoxins counteract toxin activity

Since T134, T1204 and T6249 showed a high level of toxicity in both Trans5 α and TOP10 strains, we further studied the interaction between them and corresponding antitoxins, which were cloned to a pSB4C5 derived plasmid, downstream of a P_{Tac} promoter. We measured growth of *E. coli* Trans5 α co-transformed with a P_{Tet} /toxin and its cognate P_{Tac} /antitoxin plasmids. Firstly, as Fig. 5-(a) presents, when the toxin expression was induced by 1.7 μ g/mL of aTc at the beginning of incubation, the bacteria growth was impeded. Upon addition of 0.8 mM of IPTG to induce the expression of antitoxin after four hours of incubation, growth inhibition was relieved for T134 and T1204 after 0.5 and 5 h, respectively. On the contrary, when higher concentration of aTc (5 μ g/mL) was used to induce toxins, antitoxins were only capable of lifting growth inhibition only if their expression induced simultaneously with toxins, instead of four hours later (Fig. 5-(b)). These results suggested that A134, A1204 and A6249 can only neutralize their cognate toxins that are at a lower expression level. Therefore, carefully tuning the expression level of toxin and antitoxin proteins is necessary for the function of suicide system.

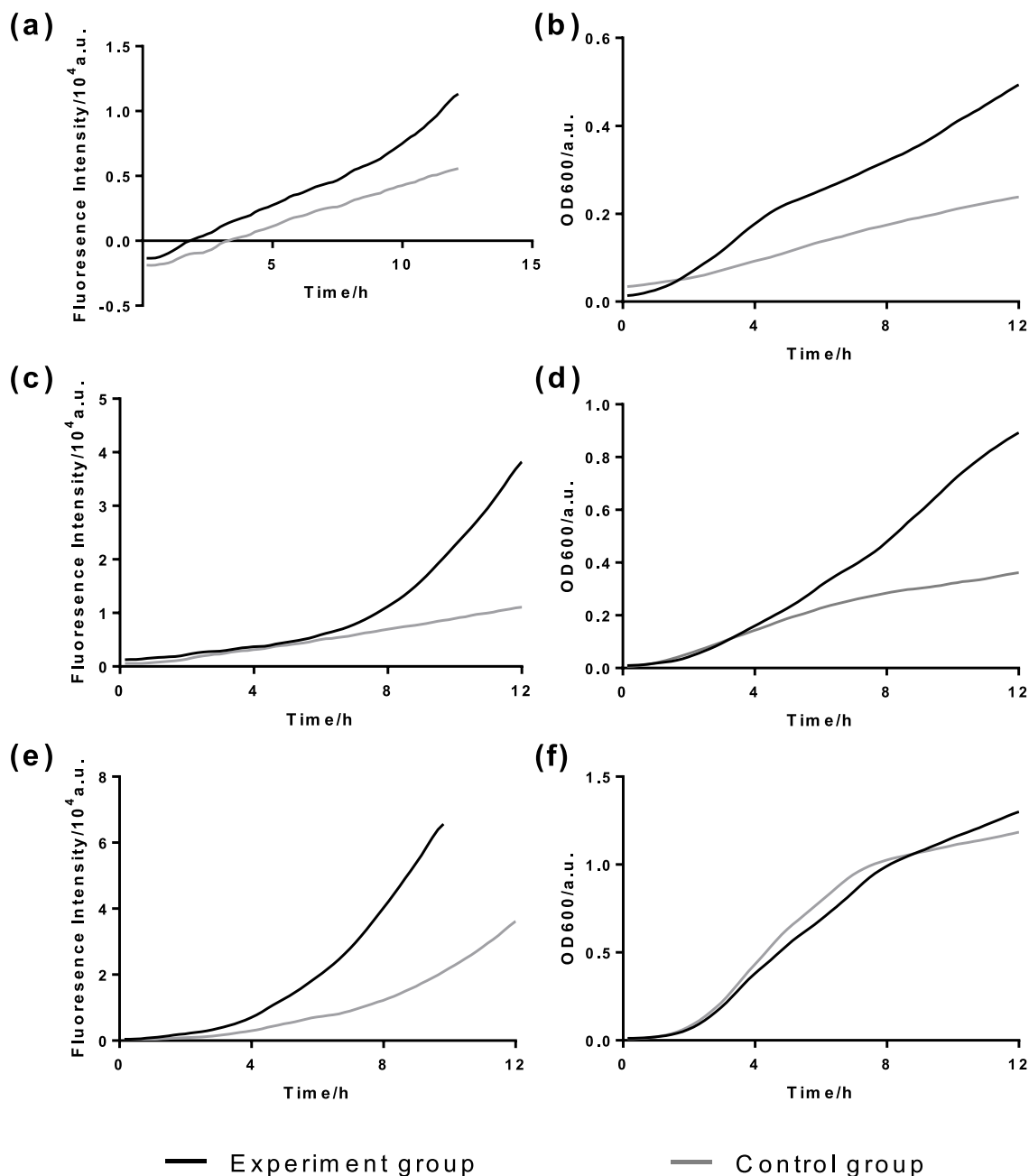

Fig. 3. The performance of *E. coli* in Experiment group and Control group. The change of fluorescence intensity over time are plotted in (a) (c) and (e), representing the total amount of degradation enzyme (TetX-GFP fusion protein) produced by bacteria. Growth curve are plotted in (b) (d) and (f), reflecting the living condition of bacteria in different group. (a), (b): [Tc] = 10 μg/mL; (c), (d): [Tc] = 5 μg/mL; (e), (f): [Tc] = 0 μg/mL.

4. Conclusion

Finding pragmatic ways to deal with antibiotic residues has already become an imminent issue. Here we report the design of the bacteria that degrades tetracycline, to which there are mainly three parts: the degrading enzyme TetX, an amplification circuit and a suicide module. To begin with, we comprehensively characterized the ability of TetX to degrade tetracycline, and assessed its *in vivo* degrading efficiency quantitatively. In accordance with previous studies on other types of antibiotics belonging to the tetracycline family [42], TetX has the ability to decompose tetracycline with a K_m of 48.93 μM. The K_m of TetX is far above the tetracycline concentration in the environment (0.005–0.5 nM),

making it necessary to increase substrate affinity of TetX through protein engineering or to implement a tetracycline concentrating mechanism in the bacteria in the future. We also gathered a collection of degradation enzymes for five other major categories of antibiotics in order to expand the applicable range of our system (Table 3). Therefore, by substituting the degradation enzyme and antibiotic responsive promoter, we can apply this system to degradation of any other antibiotics with mass production and utilization.

Next, as modularity is one of the key concepts in synthetic biology, we designed a tetracycline inducible, T7 RNAP-based amplification circuit, enabling the utilization of our degrading system in *E. coli* strains other than BL21(DE3). By measuring the

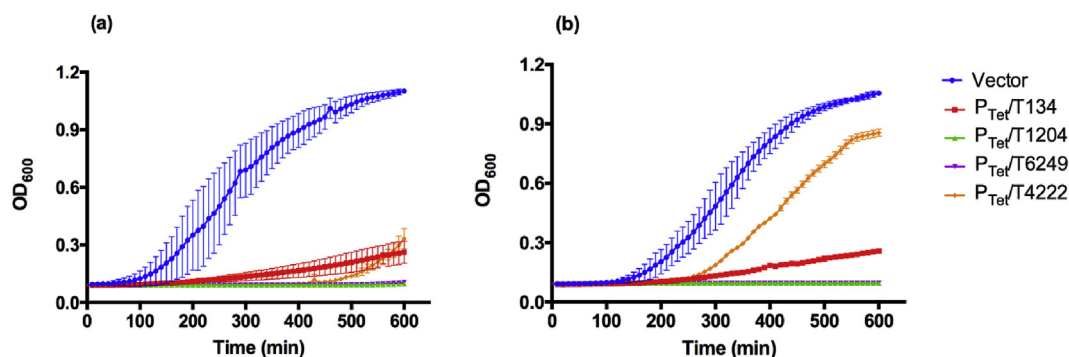

Fig. 4. Growth curves of *E. coli* strain (a) Trans5 α and (b) TOP10 harboring empty plasmid or plasmids with T134, T1204, T6249, and T4222. (a) Bacteria with empty vector showed a normal logarithmic growth curve, whereas those expressing toxin proteins displayed significant growth arrest. Induced at the beginning of incubation, T1204 and T6249 totally inhibited the growth of bacteria. *E. coli* with T6249 and T4222 demonstrated minimal growth. (b) T4222 exhibited a much lower toxicity in TOP10 than in Trans5 α (see Fig. 4-(a)). TOP10 cells expressing T4222 started to grow after approximate 200 min of induction, and continued growing until 500 min, when the value of OD₆₀₀ reached 0.9. Error bars represent SD; n = 3.

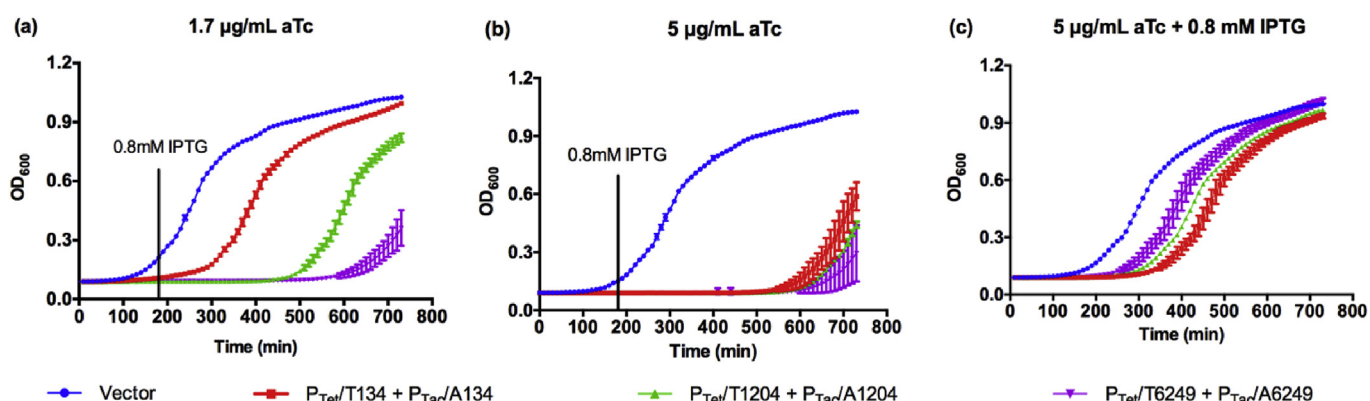

Fig. 5. Growth curves of *E. coli* strain co-expressing toxins and antitoxins. (a) Toxins were induced with 1.7 $\mu\text{g}/\text{mL}$ of aTc at the beginning of incubation, whereas antitoxins were induced by 0.8 mM of IPTG at 3 h. Antitoxin 134 and 1204 showed detoxifying effects after 0.5 and 5 h of induction, respectively. (b) Toxins cannot be neutralized if 5 $\mu\text{g}/\text{mL}$ of aTc was used for their induction, unless (c) toxins and antitoxins were induced simultaneously at the beginning of incubation. Error bars represent SD; n = 3.

Table 3

Degradation enzymes and degradation mechanism for other major antibiotics categories, based on ARDB - Antibiotic Resistance Genes Database (<http://ardb.cbcb.umd.edu/>).

Category	Antibiotics	Gene	Protein	Mechanism
Sulfonamides	Sulfamethoxazole	cpo	CPO	catalyze peroxidative halogenations of sulfamethoxazole by CPO-H ₂ O ₂
β -lactam antibiotics	Carbapenem; Cephalosporin; Cephameycin; Penicillin	bla(KPC-1)	KPC-1	break the beta-lactam antibiotic ring open
Aminoglycoside	Streptomycin	aac	Aminoglycoside N-acetyltransferase	modify aminoglycosides by acetylation
		aph	Aminoglycoside O-nucleotidyltransferase	modify aminoglycosides by adenylation
		ant	Aminoglycoside O-phosphotransferase	modify aminoglycosides by phosphorylation
Macrolide	Erythromycin	ereA	Erythromycin esterases (EreA)	catalyze enzymatic hydrolysis of the macrolactone ring
Amide alcohol	Chloramphenicol	cat	Chloramphenicol acetyltransferase (CAT)	modify aminoglycosides by acetylation

fluorescence intensity of TetX-GFP fusion protein, we proved that the amplification circuit posed minimal pressure to the growth of bacteria cells while significantly enhanced the expression level of TetX-GFP. In addition, the circuit was able to respond to various tetracycline concentrations in the environment accordingly. Finally, we evaluated the toxicity and detoxifying function of 9 selected TA systems for their potentiality to construct a suicide module. 3 out of

9 TA systems tested greatly inhibited growth when over-expressed in both *E. coli* Trans5 α and TOP10 strains, whilst other three toxins exhibited alleviated toxicity in TOP10 strain. To our best knowledge, the actual biological functions of TA systems 133, 1204, 6249, 1198, 4222, 5693, 5694, 5980 have not been biologically verified until in this research. This shall help better understanding of the nature and properties of the large pool of TA systems in prokaryotic organisms.

Our study presents promising results in the three separated parts to it, but we acknowledge that it remains a challenge to integrate those parts together. The biggest hurdle is to combine the suicide module with the amplification circuit. The performance of the two systems is expected to be coupled by the concentration of tetracycline, to which the amount of antitoxin and TetX produced is positively related. Toxin would be constitutively expressed, thus inhibiting the growth of bacteria when the tetracycline concentration is lower than a threshold. However, the actual implementation of this enticing design can be challenging, requiring precise tuning of the relative abundance of toxin, antitoxin and T7 RNAP to figure out a balance that maximize the degradation ability and best prevent the unwanted proliferation of the genetically modified organism (GMO) at the same time. Possible solutions lie in selecting the copy numbers of plasmids, RBS strength and promoter activities, which can be laborious.

Author contributions

Z.M., Z.Z., and Y.Y. contribute equally to this work. Z. Z., Z. M, Y. Y. conceived the project. Z. Z., Z. M, Y. Y. W. W., Y. X., J. H., R. C., Y. L., Y. M., B. W., Y. D., Y. L., Y. L., Y. J., Q. T. performed the experiments. Z. M., Z. Z., Y. Y. wrote the manuscript.

Conflict of interest

The authors declare no competing financial interest(s).

Acknowledgements

The authors are grateful to Prof. Xian'en Zhang at Institute of Biophysics, Chinese Academy of Sciences for intellectual advice. This work was supported by the National Key R&D Program of China (2016YFA0501502, 2016YFA0502400), the National Science Foundation of China (91313301, 21325211), University of Chinese Academy of Sciences Education Foundation.

Appendix A. Supplementary data

Supplementary data related to this article can be found at <https://doi.org/10.1016/j.synbio.2018.05.001>.

References

- Bayhan A, Unal P, Yentur G. Detection of Erythromycin residues in broiler chicken tissues. *Fleischwirtschaft* 1996;76:825–6.
- Pikkemaat MG. Microbial screening methods for detection of antibiotic residues in slaughter animals. *Anal Bioanal Chem* 2009;395:893–905.
- Pikkemaat MG, Dijk SOV, Schouten J, Rapallini M, van Egmond HJ. A new microbial screening method for the detection of antimicrobial residues in slaughter animals: the Nouws antibiotic test (NAT-screening). *Food Contr* 2008;19:781–9.
- Samanidou VF, Evaggeolopoulou EN. Analytical strategies to determine antibiotic residues in fish. *J Separ Sci* 2007;30:2549–69.
- Young MS, Jenkins KM. Determination of antibiotic residues in animal tissues and honey; Sample preparation for LC-MS analysis. *Abstr Pap Am Chem Soc* 2004;228. U102–U102.
- Barganska Z, Sleboda M, Namiesnik J. Determination of antibiotic residues in honey. *Trac Trends Anal Chem* 2011;30:1035–41.
- Benetti C, Piro R, Binato G, Angeletti R, Biancotto G. Simultaneous determination of lincosamin and five macrolide antibiotic residues in honey by liquid chromatography coupled to electrospray ionization mass spectrometry (LC-MS/MS). *Food Addit Contam* 2006;23:1099–108.
- Bohm DA, Stachel CS, Gowik P. Validation of a multi-residue method for the determination of several antibiotic groups in honey by LC-MS/MS. *Anal Bioanal Chem* 2012;403:2943–53.
- Kivrak I, Kivrak S, Harmandar M. Development of a rapid method for the determination of antibiotic residues in honey using UPLC-ESI-MS/MS. *Food Sci Tech Brazil* 2016;36:90–6.
- Lopez MI, Pettis JS, Smith IB, Chu PS. Multiclass determination and confirmation of antibiotic residues in honey using LC-MS/MS. *J Agric Food Chem* 2008;56:1553–9.
- Mujic I, Alibabic V, Jokic S, Galijasevic E, Jukic D, et al. Determination of pesticides, heavy metals, radioactive substances, and antibiotic residues in honey. *Pol J Environ Stud* 2011;20:719–24.
- Wang J. Determination of five macrolide antibiotic residues in honey by LC-ESI-MS and LC-ESI-MS/MS. *J Agric Food Chem* 2004;52:171–81.
- Wutz K, Niessner R, Seidel M. Simultaneous determination of four different antibiotic residues in honey by chemiluminescence multianalyte chip immunoassays. *Microchim Acta* 2011;173:1–9.
- Xu JZ, Wu ZX, Yang WQ, Yang GJ, Chen ZX, et al. Determination of eight macrolide antibiotic residues in honey by liquid chromatography-electrospray ionization tandem mass spectrometry. *Chin J Anal Chem* 2007;35:166–70.
- Ekuttan CE, Kang'ethe EK, Kimani VN, Randolph TF. Investigation on the prevalence of antimicrobial residues in milk obtained from urban smallholder dairy and non-dairy farming households in Dagoretti Division, Nairobi, Kenya. *East Afr Med J* 2007;84:S87–91.
- Mcewen SA, Black WD, Meek AH. Antibiotic residue prevention methods, farm-management, and occurrence of antibiotic residues in milk. *J Dairy Sci* 1991;74:2128–37.
- Samanidou V, Nisyriou S. Multi-residue methods for confirmatory determination of antibiotics in milk. *J Separ Sci* 2008;31:2068–90.
- Shendy AH, Al-Ghobashy MA, Alla SAG, Lotfy HM. Development and validation of a modified QuEChERS protocol coupled to LC-MS/MS for simultaneous determination of multi-class antibiotic residues in honey. *Food Chem* 2016;190:982–9.
- Vieira TSWJ, Ribeiro MR, Nunes MP, Machinski M, Netto DP. Detection of antibiotic residues in pasteurized milk samples from Parana State, Brazil. *Semina Ciencias Agrarias* 2012;33:791–5.
- Xu JJ, An MR, Yang R, Tan ZJ, Hao J, et al. Determination of tetracycline antibiotic residues in honey and milk by miniaturized solid phase extraction using chitosan-modified graphitized multiwalled carbon nanotubes. *J Agric Food Chem* 2016;64:2647–54.
- Jiang YH, Li MX, Guo CS, An D, Xu J, et al. Distribution and ecological risk of antibiotics in a typical effluent-receiving river (Wangyang River) in north China. *Chemosphere* 2014;112:267–74.
- Li WH, Shi YL, Gao LH, Liu JM, Cai YQ. Occurrence of antibiotics in water, sediments, aquatic plants, and animals from Baiyangdian Lake in North China. *Chemosphere* 2012;89:1307–15.
- Baym M, Lieberman TD, Kelsic ED, Chait R, Gross R, et al. Spatiotemporal microbial evolution on antibiotic landscapes. *Science* 2016;353:1147–51.
- Zhang Q, Jia A, Wan Y, Liu H, Wang K, et al. Occurrences of three classes of antibiotics in a natural river basin: association with antibiotic-resistant *Escherichia coli*. *Environ Sci Technol* 2014;48:14317–25.
- Thanasarakhan W, Kruanetr S, Deming RL, Liawruangrath B, Wangkarn S, et al. Sequential injection spectrophotometric determination of tetracycline antibiotics in pharmaceutical preparations and their residues in honey and milk samples using yttrium (III) and cationic surfactant. *Talanta* 2011;84:1401–9.
- Nouws J, van Egmond H, Smulders I, Loeffen G, Schouten J, et al. A microbiological assay system for assessment of raw milk exceeding EU maximum residue levels. *Int Dairy J* 1999;9:85–90.
- Huber MM, Gobel A, Joss A, Hermann N, Löffler D, et al. Oxidation of pharmaceuticals during ozonation of municipal wastewater effluents: a pilot study. *Environ Sci Technol* 2005;39:4290–9.
- Wang XY, Wang AQ, Ma J. Visible-light-driven photocatalytic removal of antibiotics by newly designed C₃N₄@MnFe₂O₄-graphene nanocomposites. *J Hazard Mater* 2017;336:81–92.
- Kim SD, Cho J, Kim IS, Vanderford BJ, Snyder SA. Occurrence and removal of pharmaceuticals and endocrine disruptors in South Korean surface, drinking, and waste waters. *Water Res* 2007;41:1013–21.
- Nguyen TT, Bui XT, Luu VP, Nguyen PD, Guo WS, et al. Removal of antibiotics in sponge membrane bioreactors treating hospital wastewater: comparison between hollow fiber and flat sheet membrane systems. *Bioresour Technol* 2017;240:42–9.
- Wright GD. Bacterial resistance to antibiotics: enzymatic degradation and modification. *Adv Drug Deliv Rev* 2005;57:1451–70.
- Chen K, Zhou JL. Occurrence and behavior of antibiotics in water and sediments from the Huangpu River, Shanghai, China. *Chemosphere* 2014;95:604–12.
- Xiuling JI, Fang LIU, Qunhui S, Yang LIU. Quantitative detection of sulfonamides and tetracycline antibiotics and resistance genes in sewage farms. *Ecol Environ Sci* 2011;20:927–33.
- Yang W, Moore IF, Koteva KP, Bareich DC, Hughes DW, et al. TetX is a flavin-dependent monoxygenase conferring resistance to tetracycline antibiotics. *J Biol Chem* 2004;279:52346–52.
- Sanchez-Pescador R, Brown JT, Roberts M, Urdea MS. Homology of the TetM with translational elongation factors: implications for potential modes of tetM-conferred tetracycline resistance. *Nucleic Acids Res* 1988;16:1218.
- Roberts MC. Tetracycline resistance determinants: mechanisms of action, regulation of expression, genetic mobility, and distribution. *FEMS Microbiol Rev* 1996;19:1–24.
- Li W, Atkinson GC, Thakor NS, Allas U, Lu CC, et al. Mechanism of tetracycline resistance by ribosomal protection protein Tet(O). *Nat Commun* 2013;4:1477.
- Spahn CM, Blaha G, Agrawal RK, Penczek P, Grassucci RA, et al. Localization of the ribosomal protection protein Tet(O) on the ribosome and the mechanism

- of tetracycline resistance. *Mol Cell* 2001;7:1037–45.
- [39] Levy SB. Active efflux, a common mechanism for biocide and antibiotic resistance. *J Appl Microbiol* 2002;65S:71S.
- [40] Rumbo C, Gato E, Lopez M, Ruiz de Alegria C, Fernandez-Cuenca F, et al. Contribution of efflux pumps, porins, and beta-lactamases to multidrug resistance in clinical isolates of *Acinetobacter baumannii*. *Antimicrob Agents Chemother* 2013;57:5247–57.
- [41] Vila J, Marti S, Sanchez-Cespedes J. Porins, efflux pumps and multidrug resistance in *Acinetobacter baumannii*. *J Antimicrob Chemother* 2007;59:1210–5.
- [42] Moore IF, Hughes DW, Wright GD. Tigecycline is modified by the flavin-dependent monooxygenase TetX. *Biochemistry* 2005;44:11829–35.
- [43] Steidler L, Neiryck S, Huyghebaert N, Snoeck V, Vermeire A, et al. Biological containment of genetically modified *Lactococcus lactis* for intestinal delivery of human interleukin 10. *Nat Biotechnol* 2003;21:785–9.
- [44] Wright O, Stan GB, Ellis T. Building-in biosafety for synthetic biology. *Microbiology* 2013;159:1221–35.
- [45] Mandell DJ, Lajoie MJ, Mee MT, Takeuchi R, Kuznetsov G, et al. Biocontainment of genetically modified organisms by synthetic protein design. *Nature* 2015;518:55–60.
- [46] Ravikumar A, Liu CC. Biocontainment through reengineered genetic codes. *Chembiochem* 2015;16:1149–51.
- [47] Recorbet G, Robert C, Givaudan A, Kudla B, Normand P, et al. Conditional suicide system of *Escherichia-Coli* released into soil that uses the *Bacillus-Subtilis* *sacB* gene. *Appl Environ Microbiol* 1993;59:1361–6.
- [48] Bej AK, Perlin MH, Atlas RM. Model suicide vector for containment of genetically engineered microorganisms. *Appl Environ Microbiol* 1988;54:2472–7.
- [49] Chan CTY, Lee JW, Cameron DE, Bashor CJ, Collins JJ 'Deadman' and 'Passcode' microbial kill switches for bacterial containment. *Nat Chem Biol* 2016;12. 82–90.
- [50] Wright O, Delmans M, Stan GB, Ellis T. GeneGuard: a modular plasmid system designed for biosafety. *ACS Synth Biol* 2015;4:307–16.
- [51] Shetty R, Lizarazo M, Rettberg R, Knight TF. Assembly of Biobrick standard biological parts using three antibiotic assembly. *Synth Biol Pt B* 2011;498:311–26.
- [52] Engler C, Kandzia R, Marillonnet S. A one pot, one step, precision cloning method with high throughput capability. *PLoS One* 2008;3:e3647.
- [53] Moore IF, Hughes DW, Wright GD. Tigecycline is modified by the flavin-dependent monooxygenase TetX. *Biochemistry* 2005;44:11829–35.
- [54] Studier FW, Moffatt BA. Use of bacteriophage T7 RNA polymerase to direct selective high-level expression of cloned genes. *J Mol Biol* 1986;189:113–30.
- [55] Ramos JL, Martinez-Bueno M, Molina-Henares AJ, Teran W, Watanabe K, et al. The TetR family of transcriptional repressors. *Microbiol Mol Biol Rev* 2005;69:326–56.
- [56] Johnson EP, Strom AR, Helinski DR. Plasmid RK2 toxin protein ParE: purification and interaction with the ParD antitoxin protein. *J Bacteriol* 1996;178:1420–9.
- [57] Pedersen K, Zavialov AV, Pavlov MY, Elf J, Gerdes K, et al. The bacterial toxin RelE displays codon-specific cleavage of mRNAs in the ribosomal A site. *Cell* 2003;112:131–40.
- [58] Shao YC, Harrison EM, Bi DX, Tai C, He XY, et al. TADB: a web-based resource for Type 2 toxin-antitoxin loci in bacteria and archaea. *Nucleic Acids Res* 2011;39:D606–11.
- [59] Pellegrini O, Mathy N, Gogos A, Shapiro L, Condon C the *Bacillus subtilis* *ycdDE* operon encodes an endoribonuclease of the MazF/PemK family and its inhibitor. *Mol Microbiol* 2005;56:1139–48.
- [60] Hayes F. Toxins-antitoxins: plasmid maintenance, programmed cell death, and cell cycle arrest. *Science* 2003;301:1496–9.