

CALCULATIONS OF BIOELECTRIC POTENTIALS
II. THE CONCENTRATION POTENTIAL OF KCl IN NITELLA

By S. E. HILL AND W. J. V. OSTERHOUT

(From the Laboratories of The Rockefeller Institute for Medical Research)

(Accepted for publication, August 11, 1937)

In earlier studies¹ the electrical behavior of *Nitella* conformed to the equations of Nernst and of Henderson but recently, in a different set of cells,² we have found some apparent exceptions.

These exceptions are illustrated in Fig. 1. The theoretical curve shows the approximate change in p.d. which KCl would produce if the values were due entirely to diffusion potential in the protoplasmic surface³ and the mobility of K⁺ greatly exceeded that of Cl⁻. The values were calculated from the equation

$$\text{Change of p.d.} = 58 \frac{U - V}{U + V} \log \frac{C_1}{C_2}$$

where U and V are the mobilities of K⁺ and Cl⁻ respectively, C_1 and C_2 are the concentrations,⁴ and V is taken as zero. All these values relate to the non-aqueous surface layer of the protoplasm.

It is evident that the slopes of the observed curves do not surpass that of the theoretical curve except at certain concentrations. Thus when 0.001 M KCl is substituted for 0.000316 M the curve rises abruptly so that its slope exceeds the theoretical.

¹ Osterhout, W. J. V., *J. Gen. Physiol.*, 1929-30, **13**, 715.

² The earlier cells (which came from a different locality and will be called Lot A to distinguish them from the present cells which will be called Lot B) showed a lower concentration effect of NaCl and much less inhibitory effect of calcium on the production of negativity by KCl. This will be discussed elsewhere.

³ It is assumed that the concentration of KCl in the protoplasmic surface is directly proportional to that in the external solution.

⁴ Concentrations are employed for convenience in place of activities. If this were not done the straight line would become somewhat curved.

The reason for this abrupt rise is evident when we examine the photographic record shown in Fig. 2.

The observations were made on *Nitella flexilis*, Ag. and were recorded photographically.

Short period recording devices require for their operation either high voltage,

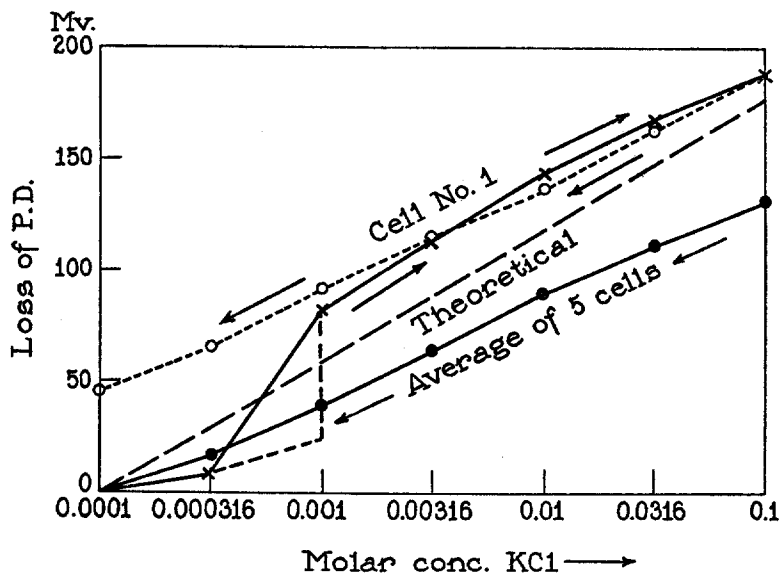

FIG. 1. Effects of KCl on p.d. The broken straight line approximates the theoretical slope of the curve showing change of diffusion potential when the concentration of KCl in contact with *Nitella* increases and the mobility of K^+ greatly exceeds that of Cl^- , partition coefficients being constant. The scale of abscissae is logarithmic: each step is made by multiplying by 3.16 ($= 10^{0.5}$).

The curve with crosses shows measurements on a single cell as the concentration of KCl increases (arrows pointing upward). The curve with open circles (dotted line) shows measurements on the same cell as the concentration of KCl decreases (arrows pointing downward). The lowest curve shows the average of five cells as the concentration of KCl decreases (see p. 556).

The slopes of the curves do not exceed the theoretical except in the curve with crosses where 0.000316 M KCl is replaced by 0.001 M KCl. At this point the change in p.d. occurs in two steps as indicated by the broken line. The first step does not exceed the theoretical; the second is larger and is due to an action current which permanently raises the level of the curve (see Fig. 2).

Temperature 20–21°C.

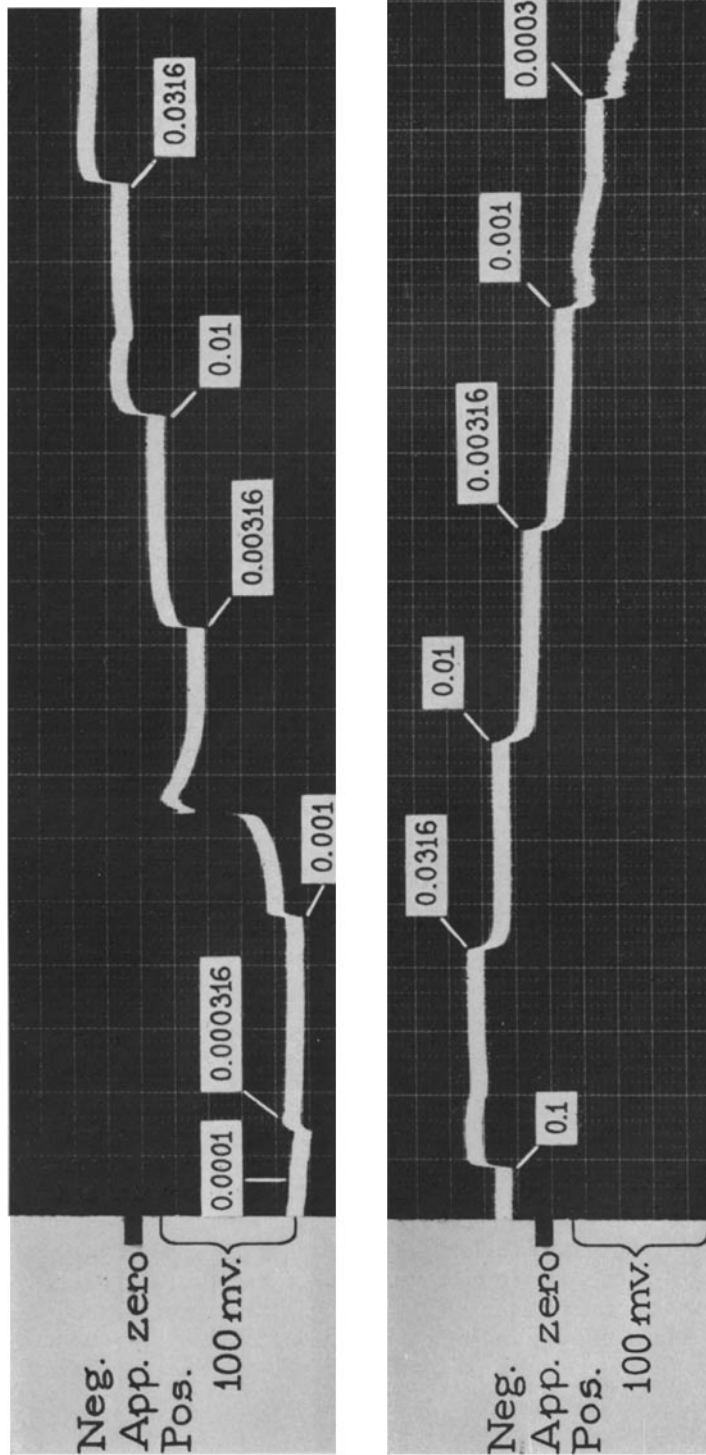

FIG. 2. Photographic record showing changes in p.d. produced by KCl. Three leads were arranged as shown in Fig. 3. The changes of solution were made only at *D* (the records of *C* and *E*, which were in contact with pond water, are omitted to save space). The p.d. at *F* (which was in contact with 0.01 m KCl) remained constant. It is assumed that its p.d. was approximately at zero, as is usually the case, and hence the label "App. zero" at the left (Cell No. 1 of Fig. 1).

At the start, *D* was in contact with 0.0001 m KCl and (reckoning from the App. zero) had a positive p.d. of 125 mv. When this was replaced by 0.000316 m KCl the curve rose 7 mv. When this was replaced by 0.001 m KCl the curve rose 15 mv. and then an action current occurred which permanently raised the level of the curve so that on returning to 0.000316 m its level was higher than before (*cf.* Fig. 1). Heavy time marks 5 seconds apart.

large current, or both. *Nitella* can furnish neither. A vacuum tube amplifier is therefore necessary.

The string galvanometer has adequate speed for *Nitella* and is used because of its simplicity. Tungsten wire replaces the quartz string, as a single tube amplifier is adequate and string breakage is eliminated. (The same amplifier may be used with a quartz string galvanometer by using a 20,000 ohm string shunt. Greater sensitivity and quicker period will result.)

The amplifier shown in Fig. 4 is designed for a galvanometer with tungsten wire in place of quartz fibre, and is grounded at *B*, the galvanometer wire being 90 volts above ground. The amplifier grounded at *B* should not be used with a quartz string unless the frame of the galvanometer is connected to the end

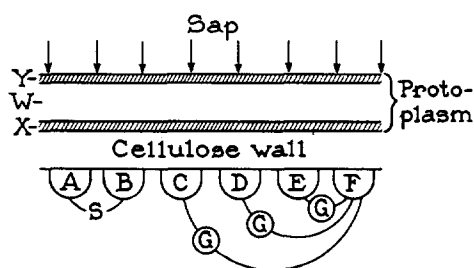

FIG. 3. Diagram to show the arrangement of leads and the supposed structure of the protoplasm which is assumed to consist of an aqueous layer *W*, an outer non-aqueous layer *X*, and an inner non-aqueous layer *Y*.

The arrows show the outwardly directed (positive) p.d. whose seat is supposed to be chiefly at *Y* when the cell is in pond water: hence the p.d. at *X* is regarded as negligible and is not shown. But under some conditions the p.d. at *X* may become important.

Each lead is connected to a separate amplifier and to one string of the 3-string Einthoven galvanometer.

of the string which goes to the slider of P_3 . If a high potential is applied between a quartz string and the frame of the instrument, the string will be attracted to the frame and the coating destroyed. This amplifier may be used with 10^6 ohms in the input circuit with little disturbance from a. c. lines, and if the *Nitella* cell and electrodes are placed in a shielded cage, its resistance may be as great as 10^7 ohms with little error. The vacuum tube is operated at its "free" grid potential in order to keep grid current at a minimum.

The function of the amplifier is to furnish current to the string galvanometer. With the circuit constants shown, for each volt change in grid potential there will be a change of 1500 microamperes in current through the galvanometer string. The linear range of the grid is about 0.25 volt each side of free grid potential. At the tungsten string tension employed, a change in grid potential of 0.05 volt

results in a string shadow movement of about 1 cm. (0.2 meter per volt). The current flowing through the string ($0.05 \times 1500 = 75$ microamperes) is about 400 times that necessary to produce a similar movement of a quartz string at conven-

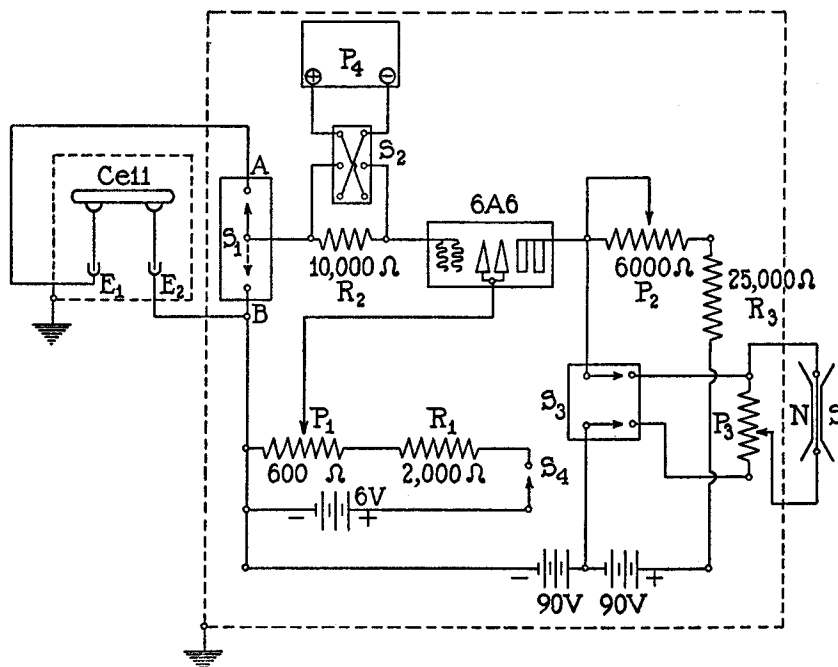

FIG. 4. Arrangement of amplifier.

- $S_1 S_2 S_3$ = General Radio No. 339 B low capacity switches.
 S_4 = toggle switch.
 $P_1 P_2$ = General Radio No. 314 A potentiometers.
 P_3 = 600 ohm No. 314 A General Radio potentiometer (for tungsten string).
 = 20,000 ohm No. 314 A General Radio potentiometer (for quartz string).
 P_4 = any available shielded potentiometer.
 $R_1 R_2 R_3$ = International Resistance Co. 10 watt wire wound resistors.
 $E_1 E_2$ = saturated calomel electrodes.
 Cell = single cell of *Nitella*.

tional electrocardiogram tensions. Therefore the sensitivity with a quartz string instrument would be $0.050 \div 400$ or 0.000125 volt per cm. (80 meters per volt).

In use, switch 1 is thrown to position A with no cell in the circuit, and P_2 adjusted until the galvanometer string is at zero. S_1 is then thrown to position B,

and P_1 is adjusted until the string is again at zero. This procedure is repeated once. With S_1 in position B , a calibrating potential is now applied across R_2 , and P_3 is adjusted until the desired sensitivity is reached. Alternatively, the string tension may be adjusted. With the 3-string galvanometer, it is our custom to adjust the strings to approximately the same deflection with the same settings of the three potentiometers (P_3) and then make exact adjustments with the potentiometers. With a cell in the circuit, the calibrating potential is recorded. No difference will be found between the series and direct calibrations if the amplifier is in proper adjustment.

The apparatus is assembled in grounded iron boxes of the sort obtainable at radio supply stores, and all external wires are covered with grounded copper shielding. All controls have insulated shafts extending through the shielding.

All measurements were made from photographic records.

The plants are transported directly from the pond to the laboratory and immediately washed in tap water with as little mechanical manipulation as possible. They are then placed in Solution A⁵ in enamel ware tubs covered with glass plates and kept in a cold room at $15^\circ \pm 1^\circ\text{C}$.

To prepare a cell for experiments neighboring cells are cut away, leaving at each end a strip of dead cell wall about 10 mm. in length by which the cell can be picked up with bone-tipped forceps which do not actually touch the living cell.⁶ The cells thus prepared are allowed to stand for several days in Solution A before being used.

The experiments described in this paper were made with flowing contacts, as shown in Fig. 5. A paraffin block P is shown in cross-section with a strip of filter paper F resting on it. The *Nitella* cell N rests on this and is covered with a thin layer of moist cotton C . Solution runs from the tube T over the cell and down to the cup B . The filter paper touches the tube T and the cup which in turn touches the waste beaker so that no drops are formed at any point. A continuous flow is maintained even during a change of solutions. For this purpose the old solution is allowed to run out until the funnel is nearly empty. The new solution is then poured in so that it follows the old solution without interruption.

Connections to the string galvanometer (through the calomel electrodes) are made as shown in Fig. 3. Care is taken to maintain a moist atmosphere around the exposed parts of the cell.

The pH of the solutions of inorganic salts between 6 and 9 has little effect on *Nitella* and no especial precautions on this score are needed.

The temperature varied between 20 and 21°C.

In making the record shown in Fig. 2, three places on the cell (C , D , and E , Fig. 3) were connected (through separate amplifiers and

⁵ For the composition of this see Osterhout, W. J. V., and Hill, S. E., *J. Gen. Physiol.*, 1933-34, **17**, 87.

⁶ Cf. Osterhout, W. J. V., *Biol. Rev.*, 1931, **6**, 369; *Ergebn. Physiol.*, 1933, **35**, 967.

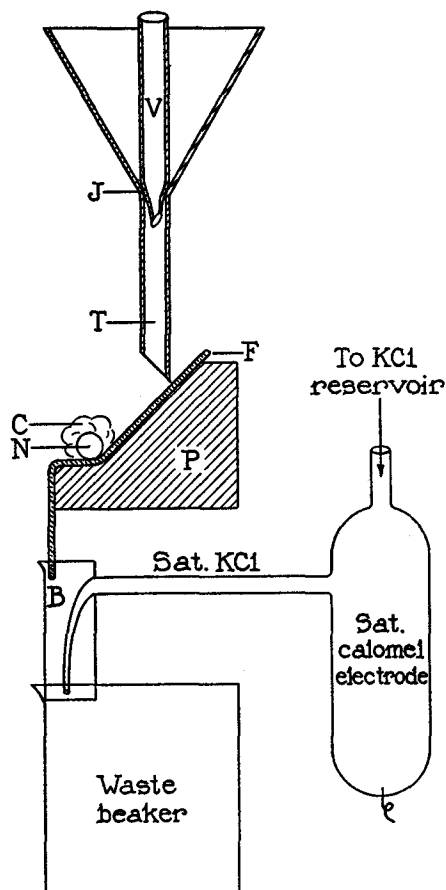

FIG. 5. Shows a cross-section of the arrangement of flowing contact. The solution is poured into the funnel. The rate of flow is determined by a groove in the ground joint *J*. Formation of slugs of water in the 3 mm. tube is prevented by the vent tube *V*. The solutions flow from the upright tube *T* to filter paper *F* which lies on a paraffin block *P*. On this rests a *Nitella* cell, *N*, covered with moist cotton, *C*; thus the solution flows completely around the cell. The filter paper (several layers) touches the tube *T* and enters the cup *B* filled with saturated KCl. Cup *B* overflows into a waste beaker which it touches so that formation of drops is precluded.

Connection to the calomel electrode is made by means of a tube filled with saturated KCl: this tube is fused with cup *B* and with the calomel electrode vessel. The bridge and cup are flushed out by a constant small flow of saturated KCl from a reservoir.

The p.d. of the liquid junction between the saturated KCl in cup *B* and the other solution at the top of cup *B* is in most cases negligible.

through the 3-string Einthoven galvanometer) to a spot F at the right end of the cell. The spot F was in contact with 0.01 M KCl which kept the p.d. constant, approximately at zero.⁷ Any change in p.d. at F would cause simultaneous changes at C , D , and E . The absence of such changes was shown by the records⁸ of C and E (omitted to save space). Hence we may be sure that all the alterations seen in Fig. 2 took place at D .

The record starts with 0.0001 M KCl at D which shows a positive⁹ potential¹⁰ of 125 mv. When the external concentration was raised to 0.000316 M the curve rose 7 mv. (indicating a loss of potential¹¹).

When 0.001 M KCl was applied the curve jumped up 15 mv. This was soon followed by a gradual rise and an action current¹² after which the level of the curve remained considerably higher.

This raises some interesting questions which involve the structure of the protoplasm. We suppose that the protoplasm consists of an aqueous layer W (Fig. 3, p. 544) with an outer (X) and an inner (Y) non-aqueous layer. The outwardly directed (positive) p.d. appears to be due to an outward gradient¹³ of K^+ across Y .

When the potential at D has been lowered by 22 mv. (by applying 0.000316 M KCl followed by 0.001 M) we may suppose that an adjoining region D_1 , only a few microns from the edge of the drop of 0.001 M KCl covering D_1 , discharges into D in the usual way.^{13, 14} This, of

⁷ This was not measured on this cell but was determined for other cells of the same lot by leading off from a spot in contact with 0.01 M KCl to one in contact with 0.01 M KCl saturated with chloroform which latter reduces the p.d. to zero.

⁸ C and E were in contact with pond water during the entire experiment.

⁹ The potential is regarded as positive when positive current tends to flow from the sap across the protoplasm to the external solution.

¹⁰ This value is reckoned from the zero given on the record which depends on the assumption that the p.d. at F is zero (*cf.* footnote 7).

¹¹ See earlier experiments, Osterhout, W. J. V., and Harris, E. S., *J. Gen. Physiol.*, 1928-29, **12**, 761; Osterhout, W. J. V., *J. Gen. Physiol.*, 1929-30, **13**, 715.

¹² It might be thought that this comes from mechanical stimulation but in that case the start of the action current would be abrupt and not gradual (*cf.* Osterhout, W. J. V., and Hill, S. E., *J. Gen. Physiol.*, 1930-31, **14**, 473). Mechanical stimulation is very improbable in view of the precautions taken to avoid it in changing solutions (see p. 546).

¹³ Osterhout, W. J. V., *J. Gen. Physiol.*, 1934-35, **18**, 215.

¹⁴ Osterhout, W. J. V., *Biol. Rev.*, 1931, **6**, 369.

course, is not recorded¹⁵ at *D*. It may involve only a partial loss of P.D. at *D*₁ for we find that it is not propagated to *C* and *E*¹⁶ (this is often the case with discharges involving incomplete loss of potential in *Nitella*).

We suppose that such a discharge involves an increase in permeability at *D*₁ accompanied by a movement of substances (organic and inorganic) from the sap into *W*. If these substances diffusing along *W* to *D* (only a few microns distant) cause an increase in the permeability¹⁷ of *Y* at *D* we can understand why an action current occurs at *D*. The delay¹⁸ after the application of 0.001 M KCl would be due to the time required for the diffusion of substances from *D*₁ to *D* in *W*.

The loss of potential due to the action current at *D*, amounting to 77 mv. at the spike, is presumably larger than at *D*₁. At any rate it is propagated and appears at *C* and *E*.

When an ascending series of concentrations of KCl is applied an action current is regularly encountered at 0.001 M to 0.005 M KCl.

We suppose therefore that the action current at *D* is brought about by the application of KCl which depresses the P.D. at *D*. But such a depression brought about by the application of NaCl seldom produces an action current.¹⁹ This may be due to the fact that, as Blinks has shown,²⁰ KCl lowers the resistance of the protoplasm much more than NaCl does. The lowered resistance would facilitate the discharge of *D*₁ into *D*. It is possible that the presence of KCl in the external solution acts in other ways to facilitate the production of the action current.

¹⁵ This is to be expected since there need be no change of P.D. at *D*. When a discharge occurs the change of P.D. takes place at the source and not at the sink. This is clearly shown when the sink is a dead spot.

¹⁶ The records of *C* and *E* are omitted to save space.

¹⁷ It may seem strange that *Y* which is in contact with sap at its inner surface should suffer an increase in permeability when sap reaches the outer surface. But this is less surprising when we remember that *Valonia* soon dies when placed in its own sap and that the process of death is accompanied by a great increase in permeability in both *Y* and *X*. Cf. Osterhout, W. J. V., *J. Gen. Physiol.*, 1924-25, **7**, 561.

¹⁸ As would be expected, the duration of this delay is variable.

¹⁹ When an action current occurs there is no extra loss.

²⁰ Blinks, L. R., *J. Gen. Physiol.*, 1929-30, **13**, 495.

When an action current is produced by KCl the subsequent level of the curve is higher than before. For convenience we shall refer to this as the "extra loss" of potential due to the action current. This extra loss is evident in the subsequent course of the curve even after the external KCl has been raised to 0.1 M and lowered again to 0.000316 M for we then find the curve at a higher level than when 0.000316 M KCl was first applied (Figs. 1 and 2).

In order to see whether the extra loss remains longer in evidence the external KCl was again raised to 0.1 M and lowered to 0.000316 M (stepwise as in Fig. 2). Above 0.001 M this curve practically duplicated that in Fig. 2 and the extra loss was in evidence throughout.

Is the extra loss due to changes in X or in Y or in both? Let us first discuss X . In previous experiments we have observed a permanent loss of potential after an action current. This has been explained as follows.²¹ The spike of the action current is due to an increase in the permeability of Y which allows K^+ to move out of the sap (where its concentration is about 0.05 M) into W . This lessens the gradient²² of K^+ across Y and hence lowers the outwardly directed (positive) potential. At the same time an organic substance, called for convenience²³ R , coming out of the sap makes X more sensitive to the action of K^+ and thus increases the inwardly directed (negative) potential due to the external KCl acting on X . We suppose that even if Y regains its original positive potential during recovery there remains the extra loss of potential due to the increased effect on X of the external KCl.

If the increased sensitivity of X to KCl is due to an organic substance R which comes out of the cell sap we might expect the extra loss of P.D. to persist as long as R remains in X . It would seem that there is one group of substances, which may be called R_p for convenience, which increases the sensitivity of X to KCl and another group, which may be called R_A , which facilitates the production of action currents. There is some unpublished evidence²⁴ that potassium

²¹ Osterhout, W. J. V., and Hill, S. E., *J. Gen. Physiol.*, 1934-35, **18**, 681.

²² The loss of P.D. might also be due to mechanical breaks in Y . Cf. Osterhout, W. J. V., and Harris, E. S., *J. Gen. Physiol.*, 1927-28, **11**, 673. Hill, S. E., *J. Gen. Physiol.*, 1934-35, **18**, 357. Osterhout, W. J. V., *Proc. Nat. Acad. Sc.*, 1938, **24**, 75.

²³ Hill, S. E., and Osterhout, W. J. V., *J. Gen. Physiol.*, 1934-35, **18**, 687.

²⁴ This will be discussed in another paper.

combines with a substance which we may call HZ to form KZ, which is identical with R_p . Hence we might expect that if K^+ is removed from the external solution the R_p in X would tend to lose its potassium and consequently to lose its efficiency. This seems to be the case. The extra sensitivity to KCl and consequently the extra loss of P.D. gradually disappears when the external solution of KCl is replaced by pond water, or by Solution A or by a solution of NaCl.²⁵ It may even disappear in a few minutes in 0.0001 M KCl.²⁶ In higher concentrations of KCl its disappearance is much slower. Theoretically we might expect it to disappear eventually even in the higher concentrations of KCl since it would tend to diffuse out into the external solution.

How does this extra loss of P.D. come about? Let us return to the equation given on p. 541 which may be written

$$\text{Change of P.D.} = 58 \frac{U - V}{U + V} \log \frac{S C_1}{S C_2}$$

where C_1 and C_2 are the concentrations in the external solution and S is the partition coefficient (conc. in $X \div$ conc. in the external solution). If S remains approximately constant²⁷ the slope of the curves in Fig. 1 will depend on the value of $(U - V) \div (U + V)$. Before the action current, when the concentration of KCl is raised from 0.000316 M to 0.001 M, we have (using concentrations for convenience in place of activities)

$$15 = 58 \frac{U - V}{U + V} \log \frac{S 0.001}{S 0.000316}$$

$$\frac{15}{58 (0.5)} = \frac{U - V}{U + V}$$

²⁵ In 0.01 M NaCl or in more dilute solutions it may disappear in less than a minute. The test is made by substituting NaCl for KCl and then replacing KCl of the same concentration as before to see whether the same P.D. is observed.

²⁶ This is most easily observed by treating the cell as in Fig. 2 and when the concentration has been lowered from 0.1 M to 0.0001 M KCl leaving it until the excess loss of potential gradually disappears, as shown by the gradual downward drift of the curve.

²⁷ This is probably true under normal conditions in the absence of action currents.

whence

$$(U - V) \div (U + V) = 0.52$$

When the next change of concentration is made we have

$$28 = 58 \frac{U - V}{U + V} \log \frac{0.00316}{0.001}$$

$$\frac{28}{58(0.5)} = \frac{U - V}{U + V}$$

whence $(U - V) \div (U + V) = 1$ (this can happen only when U is extremely large as compared to V).

Evidently therefore we cannot expect the change of P.D. to exceed²⁸ 28 mv. no matter how much the value of U is increased by the action of R coming out of the sap for it cannot raise the value of $U \div V$ above unity.

Apparently the action current causes R to come out of the sap and this raises the value of $(U - V) \div (U + V)$, so that the change in P.D. is 28 mv. instead of 15 mv. In other words the action of R adds $28 - 15 = 13$ mv. to the change of P.D. and this 13 mv. appears as part of the extra loss of P.D. But as the total extra loss is 60 mv. we still have $60 - 13 = 47$ mv. to account for. This extra 47 mv. must be due to the action of R in raising S to S' . The amount of this rise can be calculated as follows. We may write

$$\text{Change of P.D. due to change of } S \text{ to } S' = 58 \log \frac{S'}{S}$$

When this change is 47 mv. we have

$$47 = 58 \log \frac{S'}{S}$$

whence $S' \div S = 6.5$.

On this basis it would appear that we can distinguish between changes in partition coefficients and changes in mobility. It may be noted that this is not possible with the equations ordinarily used for phase boundary potentials.

²⁸ The value $0.001 \div 0.000316$ in the equation will be lessened when activities are employed.

Great changes in partition coefficients may be caused by the addition of organic substances as has been repeatedly shown in unpublished experiments on models in this laboratory.²⁹

After the action current there is a considerable increase in the potassium effect; *i.e.*, the loss of P.D. produced by substituting a given concentration of KCl for the same concentration of NaCl. Before the action current this amounts to from 15 to 25 mv. After the action current it is 45 to 65 mv. This was also observed in earlier experiments.

We suppose that this indicates a greater increase in the partition coefficient³⁰ of KCl than in that of NaCl after the action current for the concentration effect of NaCl showed little or no change which indicates that the mobility³¹ of Na⁺ remained approximately constant. Hence the increase in the potassium effect must be due to changes in partition coefficient rather than in mobility. (For descending series see p. 555.)

It may be added that the experiment shown in Fig. 2 has been varied by placing the cell at first in 0.000316 M NaCl and then transferring to 0.000316 M KCl. In a typical experiment the curve jumped up 35 mv. when the KCl was applied. This was followed by a slow rise and an action current after which the level of the curve was 25 mv. higher than just before the action current. Thus the behavior of the curve before and after the action current resembled that in Fig. 2.

²⁹ The expression "partition coefficient" as here used should be interpreted in a very liberal sense to include such cases as the following. When 0.2 M Ba(OH)₂ in water is shaken with isoamyl alcohol the partition coefficient (Ba⁺⁺ in amyl alcohol ÷ Ba⁺⁺ in water) is less than 0.0005, but when the amyl alcohol contains 0.1 M oleic acid the partition coefficient rises to 0.029 because barium oleate is formed. When the aqueous solution of Ba(OH)₂ is 0.0015 M the partition coefficient rises to 3.46: the corresponding figure for Ca(OH)₂ is about 16.8. Temperature about 22°C.

³⁰ In earlier experiments the increase in the potassium effect involved an increase of the mobility of K⁺, as shown by the increase in the slope of the curve of concentration potential (when plotted as in Fig. 1). Cf. Osterhout, W. J. V., *J. Gen. Physiol.*, 1934-35, 18, 987.

³¹ In these cells (Lot B) the mobility of Na⁺ (as shown by the concentration effect) was much higher than in the cells studied earlier (Lot A).

This discussion indicates that we may account for the excess loss of potential by changes in X . But it is probable that changes occur in Y and it would seem natural to look to these to explain the fact that after the action current in Fig. 2 no subsequent action currents are produced³² by further increases³³ in the concentration of KCl. This may also be due, in part at least, to the fact that on standing the diffusion boundary between D and D_1 becomes more diffuse and this makes more difficult a discharge from D_1 into D (this has been discussed in a previous paper³⁴).

It is also possible that changes in Y might account, in part at least, for the excess loss of potential, *e.g.* by changing partition coefficients or mobilities or by a mechanical alteration (*e.g.* producing a "leaky" condition).²²

All of these suggestions are put forward merely as working hypotheses which may serve to bring the facts under a common viewpoint. Future investigation must decide their actual value.

It seems desirable before leaving this subject to consider briefly the sources of these potentials. They are, of course, thermodynamic³⁵ as distinguished from zeta potentials. In previous studies the electrical behavior of the cell could be predicted by using the equations for diffusion potential³⁶ rather than those for phase boundary potential.³⁷ In consequence they have been regarded for convenience as diffusion potentials.

³² In a few cases a second action current occurred at the next increase in the concentration of KCl. Perhaps in these cases the changes produced by the first action current were less complete.

³³ Even when all the steps shown in Fig. 2 were immediately repeated on this cell no action current occurred.

³⁴ Osterhout, W. J. V., and Hill, S. E., *J. Gen. Physiol.*, 1929-30, **13**, 547.

³⁵ This is shown by the fact that they can be measured by means of a galvanometer. According to L. R. Blinks (personal communication) *Halicystis Osterhoutii*, Blinks and Blinks, can produce continuously for several days a current about 2.5 microamperes per cm.² of cell surface. For technique see Blinks, L. R., *J. Gen. Physiol.*, 1935-36, **19**, 875.

³⁶ Osterhout, W. J. V., *J. Gen. Physiol.*, 1929-30, **13**, 715. Damon, E. B., *J. Gen. Physiol.*, 1932-33, **16**, 375.

³⁷ Donnan potentials need not be considered since nothing resembling a Donnan equilibrium exists and oxidation-reduction potentials are ruled out because no metallic electrodes were in contact with the cell (*cf.* Osterhout, W. J. V., and Hill, S. E., Cold Spring Harbor symposia on quantitative biology, Cold Spring Harbor, Long Island Biological Association, 1936, **4**, 43).

In the cells previously studied the rôle of K^+ was so predominant that other ions were neglected. For convenience we shall continue to do this but it should be understood that Na^+ plays a more important rôle in the present cells (Lot B) than in the earlier ones (Lot A). We know that potassium enters and reaches a much higher concentration in the sap than in the pond water.

One way in which p.d. might be brought about is seen in artificial cells³⁸ where the protoplasm is represented by guaiacol. When a dilute solution of potassium is placed outside the artificial cell potassium enters until its concentration in the artificial sap inside the cell is much higher than outside. During this process the potential due to the potassium compounds undergoes a change of sign. At first it is negative (inwardly directed) but as K^+ accumulates in the artificial sap the sign of the potential becomes positive (outwardly directed) as in *Nitella*.

We suppose that the positive potential in *Nitella* is due chiefly to compounds of potassium and sodium which reach a higher concentration in the sap than in the external solution. This appears to be chiefly due to a concentration gradient across *Y*, *i.e.* to a gradient from the sap, which contains about 0.05 M KCl and 0.05 M NaCl, across *Y* to *W*, which appears to contain very little of either.

We may suppose that when the cell is in pond water there is not much potential across *X* but when sufficient KCl or NaCl is added to the external solution an inwardly directed potential appears at *X*. We may make the usual assumption that the outermost portion of *X* comes almost instantaneously into equilibrium with the external solution and that the innermost portion of *X* likewise comes into equilibrium with *W*. During such experiments as are shown in Fig. 2 the penetration of KCl at one spot on the cell may not have much effect on *W* which is constantly stirred by protoplasmic movement.³⁹

If the concentration of K^+ in *W* remains constant and the external concentration of KCl is raised from 0.001 M to 0.1 M it should theoretically make no difference as far as p.d. is concerned whether we do this suddenly or stepwise (as in Fig. 2). In other words it makes no difference theoretically whether the diffusion boundary in *W* is sharp or diffuse.⁴⁰ Practically, however, we do find differences in experiments on diffusion in aqueous solutions when more than one electrolyte is involved but they are irregular and not predictable.

When the external concentration is suddenly raised from 0.001 to 0.01 M we suppose that a sharp diffusion boundary is formed in *X* as discussed in a previous paper.¹

Let us now consider briefly the effect of starting with 0.1 M KCl and proceeding stepwise in a descending series. The application of 0.1 M

³⁸ Osterhout, W. J. V., *J. Gen. Physiol.*, 1932-33, **16**, 157.

³⁹ *W* extends the whole length of the cell (usually 10 cm. or more) and the spot *D* where KCl is applied is only a centimeter in width. The thickness of *W* is undoubtedly much greater than that of *X*.

⁴⁰ MacInnes, D. A., and Yeh, Y. L., *J. Am. Chem. Soc.*, 1921, **43**, 2563. Brown, A. S., and MacInnes, D. A., *J. Am. Chem. Soc.*, 1935, **57**, 1356.

KCl causes an action current as would be expected from what is said earlier (p. 549) but there is no delay since the curve jumps up at once to beyond zero owing to the action of the external KCl on X plus the effect of the loss of p.d. at Y which is quickly superimposed.⁴¹ As in the ascending series there is a partial recovery after which the extra loss persists. To avoid superimposition the curve in Fig. 1 has been made to pass through the origin and hence does not show the extra loss.

In this case we find that the potassium effect is greater in the concentrated than in the dilute solutions. This may be due, in part at least, to contamination of the dilute solutions.

The descending series of concentrations in Fig. 1 (lowest curve showing the average of five cells) gives a smooth curve. Since the slope of this curve approaches the theoretical limit⁴² it is evident that the high value (85.45) for $U_K \div V_{Cl}$ given in a former paper is justified.

These results clearly show the importance of using methods of measurement which allow us to detect action currents. The information afforded by continuous records is often indispensable.

SUMMARY

Cells of *Nitella* have been studied which behave differently from those described in earlier papers. They show unexpectedly large changes in p.d. with certain concentrations of KCl. This is due to the production of action currents (these are recorded at the spot where KCl is applied).

A method is given for the separate evaluation of changes of p.d. due to partition coefficients and those due to mobilities.

A new amplifier and an improved flowing contact are described.

⁴¹ This effect on Y appears more quickly than in the action current of the ascending series. This might be expected since 0.1 M KCl would lower the resistance of the protoplasm more than would lower concentrations.

⁴² The theoretical slope becomes a little less when activities are taken into account. Cf. footnote 1.