



## Non-commensurate fractional linear systems: New results

Manuel D. Ortigueira<sup>a,\*</sup>, Gabriel Bengochea<sup>b</sup>

<sup>a</sup>CTS-UNINOVA and NOVA School of Science and Technology of NOVA University of Lisbon, Campus da FCT da UNL, Quinta da Torre, 2829-516 Caparica, Portugal

<sup>b</sup>Academia de Matemáticas, Universidad Autónoma de la Ciudad de México, Ciudad de México, Mexico



### HIGHLIGHTS

- It presents a partial fraction decomposition of non commensurate systems.
- Suitable inversion of each fraction is done in two ways: series and integer/fractional decomposition.

### GRAPHICAL ABSTRACT

$$\frac{1}{(s^{\frac{\alpha}{2}} - p)(s^{\frac{\beta}{2}} - q)} = \frac{p}{(s^{\frac{\alpha}{2}} - p)(ps^{\frac{\beta}{2}} - qs^{\frac{\alpha}{2}})} - \frac{q}{(s^{\frac{\beta}{2}} - q)(ps^{\frac{\alpha}{2}} - qs^{\frac{\beta}{2}})}$$

$$\checkmark \mathcal{L}^{-1}$$

$$\left\{ \begin{aligned} &= \sum_{k=0}^{\infty} \sum_{l=0}^{\infty} p^{2l-k} q^{k-l} \frac{t^{\frac{\alpha}{4}(2l-k+1) + \frac{\beta}{4}(k-l+1) - 1}}{\Gamma\left(\frac{\alpha}{4}(2l-k+1) + \frac{\beta}{4}(k-l+1)\right)} \varepsilon(t) \\ &= A e^{p^{\frac{\alpha}{2}} t} \varepsilon(t) + \frac{1}{2\pi i} \int_0^{\infty} [F(e^{-i\pi u}) - F(e^{i\pi u})] e^{-ut} du \cdot \varepsilon(t) \end{aligned} \right.$$

### ARTICLE INFO

#### Article history:

Received 19 December 2019

Revised 24 January 2020

Accepted 27 January 2020

Available online 8 February 2020

#### Keywords:

Non-commensurate order

Fractional Calculus

Partial fraction decomposition

Laplace transform

### ABSTRACT

A study of non-commensurate fractional linear system is done in a parallel way to the commensurate case. A partial fraction decomposition is accomplished using a recursive procedure. Each partial fraction is inverted in two different ways. The decomposition integer/fractional is done also. Some examples are presented.

© 2020 The Authors. Published by Elsevier B.V. on behalf of Cairo University. This is an open access article under the CC BY-NC-ND license (<http://creativecommons.org/licenses/by-nc-nd/4.0/>).

### Introduction

The last 30 years of Fractional Calculus [5,14,15] brought a remarkable progress and became popular in many scientific and technical areas [4,6–9,16] due to its ability to better describe many natural phenomena. The fact that fractional models represent systems which require lower number of parameter than those of integer order is a point in favor of fractional systems (see [2]). This is due to their capacity of supplying us with more reliable time and frequency representations.

We cannot say that there many works on non-commensurate systems. The first meaningful study was presented in [13], based on a manipulation of the transfer function and the use of the properties of Laplace transform. Another one described in [12] was based on a series expansion of the transfer function. Much of the research in fractional systems is developed for commensurate orders in a way that is a direct generalization of traditional formalism. However, most of the methods used to solve commensurate fractional linear systems cannot be easily extended to non-commensurate case. In such situation, we find the partial fraction decomposition very useful in inverting Laplace and Z transforms currently used in the study of linear systems, when performing the computation of the impulse response from the transfer function (TF). The implementation of such inversion using the decomposition of the TF in partial fractions, not only simplifies the

Peer review under responsibility of Cairo University.

\* Corresponding author.

E-mail addresses: [mdo@fct.unl.pt](mailto:mdo@fct.unl.pt) (M.D. Ortigueira), [gabriel.bengochea@uacm.edu.mx](mailto:gabriel.bengochea@uacm.edu.mx) (G. Bengochea).

<https://doi.org/10.1016/j.jare.2020.01.015>

2090-1232/© 2020 The Authors. Published by Elsevier B.V. on behalf of Cairo University.

This is an open access article under the CC BY-NC-ND license (<http://creativecommons.org/licenses/by-nc-nd/4.0/>).

procedure, but gives more insight into the characteristics of the system, namely, stability and existing vibration modes. The procedures in [1,12,13] are not suitable to display such characteristics, mainly to perform the modal decomposition.

In this paper, we look for obtaining for non-commensurate order systems such kind of decomposition, provided we know the pseudo-pole/zero factorization. We start from the simplest case where we have only two orders and two pseudo-poles and decompose it into a sum of two fractions. From it, we turn to the case of three pseudo-poles. Finally, we deduce the general case and show how add pseudo-zeros. For each term we obtain the inverse LT by using the operational method presented in [1].

The paper is organized as follows. Firstly, we present our results related to simple fraction decomposition with non-commensurate order. Then, we resolve several examples of lineal fractional systems with non-commensurate order. We continue with the decomposition of transfer function in two parts, a part of integer order and the other one of fractional order. Finally, the conclusions are presented.

**Partial fraction decomposition**

*Non-commensurate transfer function*

Consider a linear system with TF given by

$$H(s) = \frac{(s^{\beta_1} - \zeta_1)(s^{\beta_2} - \zeta_2) \cdots (s^{\beta_m} - \zeta_m)}{(s^{\alpha_1} - \gamma_1)(s^{\alpha_2} - \gamma_2) \cdots (s^{\alpha_n} - \gamma_n)}, \tag{1}$$

where the  $\gamma_i, i = 1, 2, \dots, n, \zeta_j, j = 1, \dots, m$ , are non-null pseudo-poles and pseudo-zeroes that are, not necessarily different, complex numbers. The derivative orders,  $\beta_m, \alpha_n$  are real numbers in the interval  $(0, 1)$ , and for stability reasons,  $\sum_m \beta_m \leq \sum_n \alpha_n$ .

In applications, we have a problem not easily solvable: the obtention of the factorization. To understand the difficulties we consider the relation between the factorization and the pseudo-polynomial. Consider a pseudo-polynomials with format

$$P_n(s) = (s^{\alpha_1} - \gamma_1)(s^{\alpha_2} - \gamma_2) \cdots (s^{\alpha_n} - \gamma_n), \tag{2}$$

where the  $\gamma_i$ 's are different complex numbers. Let  $\alpha = (\alpha_1, \alpha_2, \dots, \alpha_n) \in \mathbb{R}^{+n}$ . If we define

$$\begin{aligned} \lambda &= \sum_{k=1}^n \alpha_k, \\ \lambda_{j_1} &= \sum_{\substack{k=1 \\ k \neq j_1}}^n \alpha_k, \quad j_1 \in [1, n], \\ \lambda_{j_1 j_2} &= \sum_{\substack{k=1 \\ k \neq j_1 j_2}}^n \alpha_k, \quad j_1 \neq j_2, \quad j_1, j_2 \in [1, n], \\ &\vdots \\ \lambda_{j_1 j_2 \dots j_{n-1}} &= \alpha_{j_n}, \\ \lambda_{j_1 j_2 \dots j_n} &= 0, \end{aligned}$$

then (2) can be written as

$$\begin{aligned} P_n(s) &= s^\lambda - \sum_{j_1=0}^n \gamma_{j_1} s^{\lambda_{j_1}} + \sum_{\substack{j_1 j_2=0 \\ j_1 \neq j_2}}^n \gamma_{j_1} \gamma_{j_2} s^{\lambda_{j_1 j_2}} \\ &\quad - \sum_{\substack{j_1 j_2 j_3=0 \\ j_1 \neq j_2 \neq j_3}}^n \gamma_{j_1} \gamma_{j_2} \gamma_{j_3} s^{\lambda_{j_1 j_2 j_3}} + \cdots + (-1)^{n+1} \gamma_{j_n} \cdots \gamma_{j_2} \gamma_{j_1}, \tag{3} \end{aligned}$$

which shows that there are many non-factorizable pseudo-polynomials. For example,  $s^\alpha + as^\beta + b$ , with non-commensurate

orders does not have a factorization as referred. Relation (3) can serve as guide for obtaining the factorization of polynomials with a few factors.

*Two pseudo-poles case*

The simple fraction decomposition is a widely used tool in several areas of science. In the case of one variable, a well known simple result is that

$$\frac{1}{(z-a)(z-b)} = \frac{1}{z-a} - \frac{1}{z-b}, \quad a \neq b. \tag{4}$$

Our goal is the decomposition of a fraction of the type:

$$\frac{1}{(s^{\alpha_1} - \gamma_1)(s^{\alpha_2} - \gamma_2)},$$

but it is a simple task to show that it is not possible to obtain a result equal to (4). However, we can obtain a similar decomposition using a trick: if we define in (4) the parameters  $z = 1, a = \frac{s^{\alpha_1}}{\gamma_1}$  and  $b = \frac{s^{\alpha_2}}{\gamma_2}$ , with  $\gamma_1, \gamma_2$  be different non-zero complex numbers, then we obtain the result stated in next Theorem.

**Theorem 1.** Let  $\gamma_1, \gamma_2$  be different non-null complex numbers and  $\alpha_1, \alpha_2$  be positive real numbers. Then

$$\frac{1}{(s^{\alpha_1} - \gamma_1)(s^{\alpha_2} - \gamma_2)} = \frac{\gamma_1}{(s^{\alpha_1} - \gamma_1)(\gamma_1 s^{\alpha_2} - \gamma_2 s^{\alpha_1})} - \frac{\gamma_2}{(s^{\alpha_2} - \gamma_2)(\gamma_1 s^{\alpha_2} - \gamma_2 s^{\alpha_1})}.$$

**Remark 1.** If  $\gamma_1 = \gamma_2 = 0$ , the theorem does not apply, because we have no pseudo-pole, but only a branchcut point. For  $\gamma_1 \neq 0$  and  $\gamma_2 = 0$ , we observe that  $\frac{1}{(s^{\alpha_1} - \gamma_1)s^{\alpha_2}} = \frac{s^{-\alpha_2}}{(s^{\alpha_1} - \gamma_1)}$ . Therefore, we invert  $\frac{1}{(s^{\alpha_1} - \gamma_1)}$  and afterwards perform the anti-derivation corresponding to  $s^{-\alpha_2}$ .

**Remark 2.** It is important to note that the term  $(\gamma_1 s^{\alpha_2} - \gamma_2 s^{\alpha_1})$  has no zeroes in the first Riemann sheet, in the non-commensurate case we are dealing. Therefore, each term in the right hand side in (1) only has a pseudo-pole. If the orders commensurate, we can continue the decomposition as we do in the classic procedure.

*General decomposition*

In the next theorem, we tackle the case with three simple pseudo-poles.

**Theorem 2.** Let  $\gamma_1, \gamma_2, \gamma_3$  be different non-null complex numbers, and  $\alpha_1, \alpha_2, \alpha_2$  be positive real numbers. Then

$$\begin{aligned} \frac{1}{(s^{\alpha_1} - \gamma_1)(s^{\alpha_2} - \gamma_2)(s^{\alpha_3} - \gamma_3)} &= \frac{\gamma_1^2}{(\gamma_2 s^{\alpha_1} - \gamma_1 s^{\alpha_2})(\gamma_3 s^{\alpha_1} - \gamma_1 s^{\alpha_3})(s^{\alpha_1} - \gamma_1)} \\ &\quad + \frac{\gamma_2^2}{(\gamma_1 s^{\alpha_2} - \gamma_2 s^{\alpha_1})(\gamma_3 s^{\alpha_2} - \gamma_2 s^{\alpha_3})(s^{\alpha_2} - \gamma_2)} \\ &\quad + \frac{\gamma_3^2}{(\gamma_2 s^{\alpha_3} - \gamma_3 s^{\alpha_2})(\gamma_1 s^{\alpha_3} - \gamma_3 s^{\alpha_1})(s^{\alpha_3} - \gamma_3)}. \end{aligned}$$

**Proof.** From Theorem 1, we obtain that

$$\frac{1}{(s^{\alpha_1} - \gamma_1)(s^{\alpha_2} - \gamma_2)(s^{\alpha_3} - \gamma_3)} = -\frac{\gamma_1}{(s^{\alpha_1} - \gamma_1)(s^{\alpha_3} - \gamma_3)(\gamma_2 s^{\alpha_1} - \gamma_1 s^{\alpha_2})} - \frac{\gamma_2}{(s^{\alpha_2} - \gamma_2)(s^{\alpha_3} - \gamma_3)(\gamma_1 s^{\alpha_2} - \gamma_2 s^{\alpha_1})}.$$

Applying again the Theorem 1, it follows that

$$\frac{1}{(s^{\alpha_1} - \gamma_1)(s^{\alpha_2} - \gamma_2)(s^{\alpha_3} - \gamma_3)} = \frac{\gamma_1^2}{(\gamma_2 s^{\alpha_1} - \gamma_1 s^{\alpha_2})(\gamma_3 s^{\alpha_1} - \gamma_1 s^{\alpha_3})(s^{\alpha_1} - \gamma_1)} + \frac{\gamma_2^2}{(\gamma_1 s^{\alpha_2} - \gamma_2 s^{\alpha_1})(\gamma_3 s^{\alpha_2} - \gamma_2 s^{\alpha_3})(s^{\alpha_2} - \gamma_2)} + \frac{\gamma_1 \gamma_3}{(\gamma_2 s^{\alpha_1} - \gamma_1 s^{\alpha_2})(\gamma_1 s^{\alpha_3} - \gamma_3 s^{\alpha_1})(s^{\alpha_3} - \gamma_3)} + \frac{\gamma_2 \gamma_3}{(\gamma_1 s^{\alpha_2} - \gamma_2 s^{\alpha_1})(\gamma_2 s^{\alpha_3} - \gamma_3 s^{\alpha_2})(s^{\alpha_3} - \gamma_3)}.$$

Finally, simplifying we get the result. □

From Theorems 1 and 2, we deduce the general result.

**Theorem 3.** Let  $\gamma_1, \gamma_2, \dots, \gamma_n$  be different non-null complex numbers and  $\alpha_1, \alpha_2, \dots, \alpha_n$  positive real numbers. Then

$$\frac{1}{(s^{\alpha_1} - \gamma_1)(s^{\alpha_2} - \gamma_2) \dots (s^{\alpha_n} - \gamma_n)} = (-1)^{n+1} \sum_{i=1}^n \frac{\gamma_i^{n-1}}{(s^{\alpha_i} - \gamma_i) \prod_{\substack{j=1 \\ j \neq i}}^n n(\gamma_j s^{\alpha_i} - \gamma_i s^{\alpha_j})}.$$

For the case when we have multiple pseudo-poles we only need to apply several times the Theorems. To illustrate the procedure, we present the next example.

**Example 1.** Suppose that we want to apply the simple fraction decomposition to transfer function

$$H(s) = \frac{1}{(s^{\alpha_1} - \gamma_1)(s^{\alpha_2} - \gamma_2)^2}.$$

By the Theorem 1, we have that

$$\frac{1}{(s^{\alpha_1} - \gamma_1)(s^{\alpha_2} - \gamma_2)} = -\frac{\gamma_1}{(s^{\alpha_1} - \gamma_1)(\gamma_2 s^{\alpha_1} - \gamma_1 s^{\alpha_2})} - \frac{\gamma_2}{(s^{\alpha_2} - \gamma_2)(\gamma_1 s^{\alpha_2} - \gamma_2 s^{\alpha_1})}.$$

Then

$$\frac{1}{(s^{\alpha_1} - \gamma_1)(s^{\alpha_2} - \gamma_2)^2} = \frac{1}{(s^{\alpha_2} - \gamma_2)} \left( -\frac{\gamma_1}{(s^{\alpha_1} - \gamma_1)(\gamma_2 s^{\alpha_1} - \gamma_1 s^{\alpha_2})} - \frac{\gamma_2}{(s^{\alpha_2} - \gamma_2)(\gamma_1 s^{\alpha_2} - \gamma_2 s^{\alpha_1})} \right) = -\frac{\gamma_1}{(s^{\alpha_1} - \gamma_1)(s^{\alpha_2} - \gamma_2)(\gamma_2 s^{\alpha_1} - \gamma_1 s^{\alpha_2})} - \frac{\gamma_2}{(s^{\alpha_2} - \gamma_2)^2 (\gamma_1 s^{\alpha_2} - \gamma_2 s^{\alpha_1})}.$$

Again by applying Theorem 1, we get that

$$\frac{1}{(s^{\alpha_1} - \gamma_1)(s^{\alpha_2} - \gamma_2)^2} = \frac{\gamma_1^2}{(s^{\alpha_1} - \gamma_1)(\gamma_2 s^{\alpha_1} - \gamma_1 s^{\alpha_2})^2} + \frac{\gamma_1 \gamma_2}{(s^{\alpha_2} - \gamma_2)(\gamma_1 s^{\alpha_2} - \gamma_2 s^{\alpha_1})(\gamma_2 s^{\alpha_1} - \gamma_1 s^{\alpha_2})} - \frac{\gamma_2}{(s^{\alpha_2} - \gamma_2)^2 (\gamma_2 s^{\alpha_2} - \gamma_2 s^{\alpha_1})}.$$

**Remark 3.** There is an eventually simpler approach to this example that consists in taking the decomposition of Theorem 1 and compute the order 1 derivative relatively to  $\gamma_2$  in both sides of the relation.

*Simple pseudo-poles/zeros cases*

Now, we add pseudo-zeros to transfer function (1). We suppose that the number of pseudo-poles is bigger than the number of pseudo-zeros. We procedure as in Theorem 1, but we add a pseudo-zero  $\theta_1$  of order  $\alpha_3$ . A simple computation yields

$$\frac{s^{\alpha_3} - \theta_1}{(s^{\alpha_1} - \gamma_1)(s^{\alpha_2} - \gamma_2)} = -\frac{\gamma_1 s^{\alpha_3}}{(\gamma_2 s^{\alpha_1} - \gamma_1 s^{\alpha_2})(s^{\alpha_1} - \gamma_1)} - \frac{\gamma_2 s^{\alpha_3}}{(\gamma_1 s^{\alpha_2} - \gamma_2 s^{\alpha_1})(s^{\alpha_2} - \gamma_2)} - \frac{\theta_1 s^{\alpha_2}}{(\gamma_1 s^{\alpha_2} - \gamma_2 s^{\alpha_1})(s^{\alpha_1} - \gamma_1)} - \frac{\theta_1 s^{\alpha_2}}{(\gamma_2 s^{\alpha_1} - \gamma_1 s^{\alpha_2})(s^{\alpha_2} - \gamma_2)}. \tag{5}$$

For the case of three pseudo-poles and one pseudo-zero we obtain that

$$\frac{s^{\alpha_4} - \theta_1}{(s^{\alpha_1} - \gamma_1)(s^{\alpha_2} - \gamma_2)(s^{\alpha_3} - \gamma_3)} = \frac{\gamma_1^2 s^{\alpha_4}}{(\gamma_2 s^{\alpha_1} - \gamma_1 s^{\alpha_2})(\gamma_3 s^{\alpha_1} - \gamma_1 s^{\alpha_3})(s^{\alpha_1} - \gamma_1)} + \frac{\gamma_2^2 s^{\alpha_4}}{(\gamma_1 s^{\alpha_2} - \gamma_2 s^{\alpha_1})(\gamma_3 s^{\alpha_2} - \gamma_2 s^{\alpha_3})(s^{\alpha_2} - \gamma_2)} + \frac{\gamma_3^2 s^{\alpha_4}}{(\gamma_2 s^{\alpha_3} - \gamma_3 s^{\alpha_2})(\gamma_1 s^{\alpha_3} - \gamma_3 s^{\alpha_1})(s^{\alpha_3} - \gamma_3)} - \frac{\gamma_1 \theta_1 s^{\alpha_1}}{(\gamma_2 s^{\alpha_1} - \gamma_1 s^{\alpha_2})(\gamma_3 s^{\alpha_1} - \gamma_1 s^{\alpha_3})(s^{\alpha_1} - \gamma_1)} - \frac{\gamma_2 \theta_1 s^{\alpha_2}}{(\gamma_1 s^{\alpha_2} - \gamma_2 s^{\alpha_1})(\gamma_3 s^{\alpha_2} - \gamma_2 s^{\alpha_3})(s^{\alpha_2} - \gamma_2)} - \frac{\gamma_3 \theta_1 s^{\alpha_3}}{(\gamma_2 s^{\alpha_3} - \gamma_3 s^{\alpha_2})(\gamma_1 s^{\alpha_3} - \gamma_3 s^{\alpha_1})(s^{\alpha_3} - \gamma_3)}.$$

Now, we can deduce the next Theorem.

**Theorem 4.** Let  $\gamma_1, \gamma_2, \dots, \gamma_n, \theta_1$ , be different non-null complex numbers and  $\alpha_1, \alpha_2, \dots, \alpha_n, \alpha_{n+1}$ , be real numbers. Then

$$\frac{s^{\alpha_{n+1}} - \theta_1}{(s^{\alpha_1} - \gamma_1)(s^{\alpha_2} - \gamma_2) \dots (s^{\alpha_n} - \gamma_n)} = (-1)^{n+1} \sum_{i=1}^n \frac{\gamma_i^{n-1} s^{\alpha_{n+1}}}{(s^{\alpha_i} - \gamma_i) \prod_{\substack{j=1 \\ j \neq i}}^n n(\gamma_j s^{\alpha_i} - \gamma_i s^{\alpha_j})} - \sum_{i=1}^n \frac{\gamma_i^{n-2} \theta_1 s^{\alpha_i}}{(s^{\alpha_i} - \gamma_i) \prod_{\substack{j=1 \\ j \neq i}}^n n(\gamma_j s^{\alpha_i} - \gamma_i s^{\alpha_j})}.$$

For adding another pseudo-zero  $\theta_2$ , with order  $\alpha_{n+2}$ , we apply the previous Theorem and get

$$\frac{(s^{\alpha_{n+1}} - \theta_1)(s^{\alpha_{n+2}} - \theta_2)}{(s^{\alpha_1} - \gamma_1)(s^{\alpha_2} - \gamma_2) \dots (s^{\alpha_n} - \gamma_n)} = (-1)^{n+1} \sum_{i=1}^n \frac{\gamma_i^{n-1} s^{\alpha_{n+1} + \alpha_{n+2}}}{(s^{\alpha_i} - \gamma_i) \prod_{\substack{j=1 \\ j \neq i}}^n n(\gamma_j s^{\alpha_i} - \gamma_i s^{\alpha_j})} - \sum_{i=1}^n \frac{\gamma_i^{n-2} \theta_1 s^{\alpha_i + \alpha_{n+2}}}{(s^{\alpha_i} - \gamma_i) \prod_{\substack{j=1 \\ j \neq i}}^n n(\gamma_j s^{\alpha_i} - \gamma_i s^{\alpha_j})} - (-1)^{n+1} \sum_{i=1}^n \frac{\theta_2 \gamma_i^{n-1} s^{\alpha_{n+1}}}{(s^{\alpha_i} - \gamma_i) \prod_{\substack{j=1 \\ j \neq i}}^n n(\gamma_j s^{\alpha_i} - \gamma_i s^{\alpha_j})} + \sum_{i=1}^n \frac{\gamma_i^{n-2} \theta_1 \theta_2 s^{\alpha_i}}{(s^{\alpha_i} - \gamma_i) \prod_{\substack{j=1 \\ j \neq i}}^n n(\gamma_j s^{\alpha_i} - \gamma_i s^{\alpha_j})}. \tag{6}$$

The same procedure can be applied to case of more pseudo-zeros. In the next section we present some examples of our decomposition with zeros.

*Commensurate case*

In this subsection, we present some particular cases with which we verify some known results.

- Consider  $\alpha_1 = \alpha_2$  in Theorem 1. Then

$$\frac{1}{(s^{\alpha_1} - \gamma_1)(s^{\alpha_2} - \gamma_2)} = -\frac{\gamma_1 / (\gamma_2 - \gamma_1)}{(s^{\alpha_1} - \gamma_1) s^{\alpha_1}} - \frac{\gamma_2 / (\gamma_1 - \gamma_2)}{(s^{\alpha_1} - \gamma_2) s^{\alpha_1}}.$$

The previous relation can be rewritten as

$$\frac{1}{(s^{\alpha_1} - \gamma_1)(s^{\alpha_2} - \gamma_2)} = \frac{-\gamma_1}{\gamma_2 - \gamma_1} \left( \frac{1}{s^{\alpha_1} - \gamma_1} - \frac{1}{s^{\alpha_1}} \right) - \frac{\gamma_2}{\gamma_1 - \gamma_2} \left( \frac{1}{s^{\alpha_1} - \gamma_2} - \frac{1}{s^{\alpha_1}} \right) = -\frac{1}{s^{\alpha_1} - \gamma_1} + \frac{1}{s^{\alpha_1} - \gamma_2}.$$

- Now, let  $0 < \alpha_1 < 1$ ,  $0 < \alpha_2 < 1$ , and set  $\alpha_1 = m\alpha$ ,  $\alpha_2 = n\alpha$ ,  $0 < \alpha < 1$ , where  $m, n \in \mathbb{N}$ . We want to see if  $\gamma_1 s^{\alpha_2} - \gamma_2 s^{\alpha_1}$  has zeroes. Let  $s = \rho e^{i\theta}$ . We can show easily that with

$$\rho^{(m-n)\alpha} = \left| \frac{\gamma_2}{\gamma_1} \right|,$$

and

$$\theta = \frac{\arg(\gamma_2) - \arg(\gamma_1)}{(m - n)\alpha},$$

we have a zero, if  $|\theta| < \pi$ . For example, with  $\gamma_2$  and  $\gamma_1$  real numbers with the same sign, there is a zero and consequently the term  $\gamma_1 s^{\alpha_2} - \gamma_2 s^{\alpha_1}$  will contribute with another pseudo-pole to (1), but having different signs there will be no pseudo-pole.

- Consider  $\alpha_1 = \alpha_2 = \alpha_3$  in Theorem 2. Then

$$\begin{aligned} \frac{1}{(s^{\alpha_1} - \gamma_1)(s^{\alpha_2} - \gamma_2)(s^{\alpha_3} - \gamma_3)} &= \frac{\gamma_1^2}{(\gamma_3 - \gamma_1)(\gamma_2 - \gamma_1)} \left( \frac{1}{s^{2\alpha_1} (s^{\alpha_1} - \gamma_1)} \right) \\ &+ \frac{\gamma_2^2}{(\gamma_1 - \gamma_2)(\gamma_3 - \gamma_2)} \left( \frac{1}{s^{2\alpha_1} (s^{\alpha_1} - \gamma_2)} \right) \\ &+ \frac{\gamma_3^2}{(\gamma_1 - \gamma_3)(\gamma_2 - \gamma_3)} \left( \frac{1}{s^{2\alpha_1} (s^{\alpha_1} - \gamma_3)} \right). \end{aligned}$$

The previous relation can be rewritten as

$$\begin{aligned} \frac{1}{(s^{\alpha_1} - \gamma_1)(s^{\alpha_2} - \gamma_2)(s^{\alpha_3} - \gamma_3)} &= \frac{1}{(\gamma_3 - \gamma_1)(\gamma_2 - \gamma_1)} \left( \frac{1}{s^{\alpha_1} - \gamma_1} - \frac{1}{s^{\alpha_1}} - \frac{\gamma_1}{s^{2\alpha_1}} \right) \\ &+ \frac{1}{(\gamma_1 - \gamma_2)(\gamma_3 - \gamma_2)} \left( \frac{1}{s^{\alpha_1} - \gamma_2} - \frac{1}{s^{\alpha_1}} - \frac{\gamma_2}{s^{2\alpha_1}} \right) \\ &+ \frac{1}{(\gamma_1 - \gamma_3)(\gamma_2 - \gamma_3)} \left( \frac{1}{s^{\alpha_1} - \gamma_3} - \frac{1}{s^{\alpha_1}} - \frac{\gamma_3}{s^{2\alpha_1}} \right). \end{aligned}$$

Simplifying

$$\begin{aligned} \frac{1}{(s^{\alpha_1} - \gamma_1)(s^{\alpha_2} - \gamma_2)(s^{\alpha_3} - \gamma_3)} &= \frac{1}{(\gamma_3 - \gamma_1)(\gamma_2 - \gamma_1)} \left( \frac{1}{s^{\alpha_1} - \gamma_1} \right) \\ &+ \frac{1}{(\gamma_1 - \gamma_2)(\gamma_3 - \gamma_2)} \left( \frac{1}{s^{\alpha_1} - \gamma_2} \right) \\ &+ \frac{1}{(\gamma_1 - \gamma_3)(\gamma_2 - \gamma_3)} \left( \frac{1}{s^{\alpha_1} - \gamma_3} \right). \end{aligned}$$

- Consider  $\alpha_2 = 2\alpha_1$  in Theorem 1. Then

$$\frac{1}{(s^{\alpha_1} - \gamma_1)(s^{\alpha_2} - \gamma_2)} = \frac{1}{(s^{\alpha_1} - \gamma_1)(s^{\alpha_1} - \sqrt{\gamma_2})(s^{\alpha_1} + \sqrt{\gamma_2})}.$$

Using the case when  $\alpha_1 = \alpha_2 = \alpha_3$ , we get that

$$\begin{aligned} \frac{1}{(s^{\alpha_1} - \gamma_1)(s^{2\alpha_1} - \gamma_2)} &= \frac{1}{(-\gamma_2 + \gamma_2)} \left( \frac{1}{s^{\alpha_1} - \gamma_1} \right) \\ &+ \frac{1}{-2\sqrt{\gamma_2}(\gamma_1 - \sqrt{\gamma_2})} \left( \frac{1}{s^{\alpha_1} - \sqrt{\gamma_2}} \right) \\ &+ \frac{1}{2\sqrt{\gamma_2}(\gamma_1 + \sqrt{\gamma_2})} \left( \frac{1}{s^{\alpha_1} + \sqrt{\gamma_2}} \right). \end{aligned}$$

### Computing the impulse response of some fractional linear systems

In this section, in order to illustrate how to use our decomposition, we solve several fractional linear systems using the simple fraction decomposition introduced in the previous section. We show how compute the inverse Laplace transform of our basic elements. To do it, we use the results presented in Appendix A to invert each term of (1) to obtain

$$\begin{aligned} \mathcal{L}^{-1} \left\{ -\frac{\gamma_1}{(s^{\alpha_1} - \gamma_1)(\gamma_2 s^{\alpha_1} - \gamma_1 s^{2\alpha_1})} \right\} &= \\ \sum_{k=0}^{\infty} \sum_{l=0}^{\infty} \gamma_1^{2l-k} \gamma_2^{k-l} \frac{t^{(2l-k+1)\alpha_1 + (k-l+1)\alpha_2 - 1}}{\Gamma((2l-k+1)\alpha_1 + (k-l+1)\alpha_2)} \varepsilon(t), \end{aligned}$$

where  $\varepsilon(t)$  is the Heaviside unit step function.

- Example 2.** Consider the system associated to transfer function

$$H(s) = \frac{s^{\alpha_3}}{(s^{\alpha_1} - 1)(s^{\alpha_2} - 2)}. \tag{7}$$

Suppose that the input  $x(t) = \delta(t)$ . From Theorem 3 we have that

$$H(s) = -\frac{s^{\alpha_3}}{(s^{\alpha_1} - 1)(2s^{\alpha_1} - s^{\alpha_2})} - \frac{2s^{\alpha_3}}{(s^{\alpha_2} - 2)(s^{\alpha_2} - 2s^{\alpha_1})}.$$

Using the method presented in Appendix A, the solution associated to basic element

$$H_1(s) = -\frac{s^{\alpha_3}}{(s^{\alpha_1} - 1)(2s^{\alpha_1} - s^{\alpha_2})} = \frac{s^{\alpha_3}}{s^{\alpha_1} (s^{\alpha_1} - 1)(s^{\alpha_2 - \alpha_1} - 2)},$$

is given by

$$y_1(t) = \sum_{k=0}^{\infty} \sum_{l=0}^{\infty} 2^{k-l} \frac{t^{(2l-k+1)\alpha_1 + (k-l+1)\alpha_2 - \alpha_3 - 1}}{\Gamma((2l-k+1)\alpha_1 + (k-l+1)\alpha_2 - \alpha_3)} \varepsilon(t),$$

and for

$$H_2(s) = -\frac{2s^{\alpha_3}}{(s^{\alpha_2} - 2)(s^{\alpha_2} - 2s^{\alpha_1})} = \frac{s^{\alpha_3}}{s^{\alpha_2} (s^{\alpha_2} - 2)(s^{\alpha_1 - \alpha_2} - \frac{1}{2})},$$

is

$$y_2(t) = \sum_{k=0}^{\infty} \sum_{l=0}^{\infty} 2^{2l-k} \frac{t^{(2l-k+1)\alpha_2 + (k-l+1)\alpha_1 - \alpha_3 - 1}}{\Gamma((2l-k+1)\alpha_2 + (k-l+1)\alpha_1 - \alpha_3)} \varepsilon(t).$$

It follows that

$$\mathcal{L}^{-1} \left\{ -\frac{s^{\alpha_3}}{(s^{\alpha_1} - 1)(2s^{\alpha_1} - s^{\alpha_2})} \right\} = y_1(t),$$

and

$$\mathcal{L}^{-1} \left\{ -\frac{2s^{\alpha_3}}{(s^{\alpha_2} - 2)(s^{\alpha_2} - 2s^{\alpha_1})} \right\} = y_2(t).$$

Therefore the solution  $y(t)$  of system (7) is

$$y(t) = y_1(t) + y_2(t). \tag{8}$$

Now, if we have that  $x(t) = \varepsilon(t)$  in (7), then we only need calculate the integral (omitting the sum of constant) to (8). Therefore the solution of (7) with  $x(t) = \varepsilon(t)$  is given by

$$\begin{aligned} y(t) &= \sum_{k=0}^{\infty} \sum_{l=0}^{\infty} 2^{k-l} \frac{t^{(2l-k+1)\alpha_1 + (k-l+1)\alpha_2 - \alpha_3}}{\Gamma((2l-k+1)\alpha_1 + (k-l+1)\alpha_2 - \alpha_3 + 1)} \varepsilon(t) \\ &+ \sum_{k=0}^{\infty} \sum_{l=0}^{\infty} 2^{2l-k} \frac{t^{(2l-k+1)\alpha_2 + (k-l+1)\alpha_1 - \alpha_3}}{\Gamma((2l-k+1)\alpha_2 + (k-l+1)\alpha_1 - \alpha_3 + 1)} \varepsilon(t). \end{aligned}$$

- Example 3.** Consider the system associated to transfer function

$$H(s) = \frac{1}{(s^{\alpha_1} - \gamma_1)(s^{\alpha_2} - \gamma_2)}. \tag{9}$$

Suppose that the input  $x(t) = \delta(t)$ . From Theorem 3 we have that

$$H(s) = -\frac{\gamma_1}{(s^{\alpha_1} - \gamma_1)(\gamma_2 s^{\alpha_1} - \gamma_1 s^{\alpha_2})} - \frac{\gamma_2}{(s^{\alpha_2} - \gamma_2)(\gamma_1 s^{\alpha_2} - \gamma_2 s^{\alpha_1})}.$$

Using the method presented in Appendix A, the solution associated to basic element

$$H_1(s) = -\frac{\gamma_1}{(s^{\alpha_1} - \gamma_1)(\gamma_2 s^{\alpha_1} - \gamma_1 s^{\alpha_2})} = \frac{1}{s^{\alpha_1} (s^{\alpha_1} - \gamma_1) (s^{\alpha_2 - \alpha_1} - \frac{\gamma_2}{\gamma_1})},$$

is given by

$$y_1(t) = \sum_{k=0}^{\infty} \sum_{l=0}^{\infty} \gamma_1^{2l-k} \gamma_2^{k-l} \frac{t^{(2l-k+1)\alpha_1 + (k-l+1)\alpha_2 - 1}}{\Gamma((2l-k+1)\alpha_1 + (k-l+1)\alpha_2)} \varepsilon(t),$$

and for

$$H_2(s) = -\frac{\gamma_2}{(s^{\alpha_2} - \gamma_2)(\gamma_1 s^{\alpha_2} - \gamma_2 s^{\alpha_1})} = \frac{1}{s^{\alpha_2} (s^{\alpha_2} - \gamma_2) (s^{\alpha_1 - \alpha_2} - \frac{\gamma_1}{\gamma_2})},$$

is

$$y_2(t) = \sum_{k=0}^{\infty} \sum_{l=0}^{\infty} \gamma_2^{2l-k} \gamma_1^{k-l} \frac{t^{(2l-k+1)\alpha_2 + (k-l+1)\alpha_1 - 1}}{\Gamma((2l-k+1)\alpha_2 + (k-l+1)\alpha_1)} \varepsilon(t).$$

It follows that

$$\mathcal{L}^{-1} \left\{ -\frac{\gamma_1}{(s^{\alpha_1} - \gamma_1)(\gamma_2 s^{\alpha_2} - \gamma_1 s^{\alpha_2})} \right\} = y_1(t),$$

and

$$\mathcal{L}^{-1} \left\{ -\frac{\gamma_2}{(s^{\alpha_2} - \gamma_2)(\gamma_1 s^{\alpha_2} - \gamma_2 s^{\alpha_2})} \right\} = y_2(t).$$

Therefore the solution  $y(t)$  of system (9) is

$$y(t) = y_1(t) + y_2(t).$$

**Example 4.** Consider the transfer function

$$H(s) = \frac{s^{\alpha_3} - 2}{(s^{\alpha_1} - i)(s^{\alpha_2} + i)}, \tag{10}$$

where  $i = \sqrt{-1}$ . We want the impulse response for the particular case in which  $\alpha_1 = \alpha_2$ . Applying (5) to transfer function (10), we get that

$$\begin{aligned} \frac{s^{\alpha_3} - 2}{(s^{\alpha_1} - i)(s^{\alpha_2} + i)} &= \frac{is^{\alpha_3}}{(is^{\alpha_1} + is^{\alpha_2})(s^{\alpha_1} - i)} + \frac{is^{\alpha_3}}{(is^{\alpha_2} + is^{\alpha_1})(s^{\alpha_2} + i)} \\ &\quad - \frac{2s^{\alpha_1}}{(is^{\alpha_2} + is^{\alpha_1})(s^{\alpha_1} - i)} + \frac{2s^{\alpha_2}}{(is^{\alpha_1} + is^{\alpha_2})(s^{\alpha_2} + i)} \\ &= \frac{is^{\alpha_3} - 2s^{\alpha_1}}{(is^{\alpha_1} + is^{\alpha_2})(s^{\alpha_1} - i)} + \frac{is^{\alpha_3} + 2s^{\alpha_2}}{(is^{\alpha_2} + is^{\alpha_1})(s^{\alpha_2} + i)}. \end{aligned}$$

Because  $\alpha_1 = \alpha_2$ , then

$$\frac{s^{\alpha_3} - 2}{(s^{\alpha_1} - i)(s^{\alpha_1} + i)} = -\frac{i}{(s^{\alpha_1} + i)} + \frac{i}{(s^{\alpha_1} - i)} + \frac{1/2s^{\alpha_3}}{s^{\alpha_1}(s^{\alpha_1} + i)} + \frac{1/2s^{\alpha_3}}{s^{\alpha_1}(s^{\alpha_1} - i)}.$$

Following the methodology used in the previous examples, we obtain that the solution  $y(t)$  of system (10) is given by

$$y(t) = 2 \sum_{k=1}^{\infty} (-1)^k \frac{t^{2k\alpha_1 - 1}}{\Gamma(2k\alpha_1)} \varepsilon(t) + \sum_{k=1}^{\infty} (-1)^{k+1} \frac{t^{2k\alpha_1 - \alpha_3 - 1}}{\Gamma(2k\alpha_1 - \alpha_3)} \varepsilon(t),$$

which is a real solution.

**Integer/fractional inversion of each partial fraction**

The solution supplied by the approach presented above does not show the underlying structure of a TF. This limitation is revealed when we try to compute its inversion by using the Bromwich integral for inverting the LT. We start by fixing a branch cut line on the left complex half-plane, since the TF must be analytic on the right half plane. Let us choose the left half real axis for the cut and assume that each term of the TF is continuous from above on the branch cut line. As seen, it verifies  $\lim_{s \rightarrow \infty} H(s) = 0$ ,  $|\arg(s)| < \pi$ . We will assume that  $\lim_{s \rightarrow 0} sH(s) = 0$  so that there is a finite initial value [3,11].

Consider (6) where we illustrate a general decomposition of a TF with two pseudo-zeros. As seen the decomposition involves terms having the form:

$$F(s) = \frac{s^\beta}{(s^{\alpha_i} - \gamma_i) \prod_{\substack{j=1 \\ j \neq i}}^n n(\gamma_j s^{\alpha_j} - \gamma_i s^{\alpha_j})}, \tag{11}$$

where  $\beta$  is such that  $\lim_{s \rightarrow \infty} F(s) = 0$ ,  $|\arg(s)| < \pi$ , and  $\lim_{s \rightarrow 0} sF(s) = 0$ .

**Remark 4.**

- We remember that a given pseudo-pole  $p$ , corresponding to an order  $a$ , is a pole, if when  $s = |s|e^{i\theta}$  and  $p = |p|e^{i\phi}$ , we have  $|s| = |p|^{1/a}$  and  $\theta = \phi/a$ . However, we have  $-\pi < \theta \leq \pi$  and, therefore, we only obtain a pole if  $-a\pi < \phi \leq a\pi$ .

- The term  $G(s) = \prod_{j=1}^n (\gamma_j s^{\alpha_j} - \gamma_i s^{\alpha_j})$  in (11) is analytic in the first Riemann surface and has no zeroes (of course in the analyticity region that excludes the origin that is the branch cut point).

In these conditions we can use the integration path  $\mathcal{C}$  in Fig. 1, [3,10], and we apply the residue theorem. Let  $u \in \mathbf{R}^+$  and consider  $F(e^{i\pi}u)$  and  $F(e^{-i\pi}u)$ , the values of  $F(s)$  immediately above and below the branch cut line. Proceeding as in [3] we obtain

$$f(t) = A_i e^{\gamma_i^{1/\alpha_i} t} \varepsilon(t) + \frac{1}{2\pi i} \int_0^\infty [F(e^{-i\pi}u) - F(e^{i\pi}u)] e^{-ut} du \cdot \varepsilon(t), \tag{12}$$

where the constant  $A_i$  is the residue of (11) at  $\gamma_i^{1/\alpha_i}$ :

$$A_i = \frac{\gamma_i^{\frac{\beta}{\alpha_i}}}{\alpha_i \gamma_i^{1/\alpha_i - 1} \prod_{\substack{j=1 \\ j \neq i}}^n (\gamma_j \gamma_i - \gamma_i^{\frac{\alpha_j}{\alpha_i} + 1})}.$$

Computing the LT of both sides in (12) we obtain

$$F(s) = F_i(s) + F_f(s),$$

where the integer order part is

$$F_i(s) = \frac{A_i}{s - \gamma_i^{1/\alpha_i}}, \quad \text{Re}(s) > \max(\text{Re}(\gamma_i^{1/\alpha_i})),$$

and the fractional part is

$$F_f(s) = \frac{1}{2\pi i} \int_0^\infty [F(e^{-i\pi}u) - F(e^{i\pi}u)] \frac{1}{s+u} du, \tag{13}$$

valid for  $\text{Re}(s) > 0$ .

The above steps led us to realize that:

- For  $\alpha_i = 1$ , we have no fractional component.
- For  $\alpha_i < 1$ , we may have two components depending on the location of  $\gamma_i$  in the complex plane
  - If  $|\arg(\gamma_i)| > \pi\alpha_i$ , then we do not have the integer order component; it is a purely fractional system.
  - If  $|\arg(\gamma_i)| \leq \pi\alpha_i$ , then it is mixed character system in the sense that we have both components.

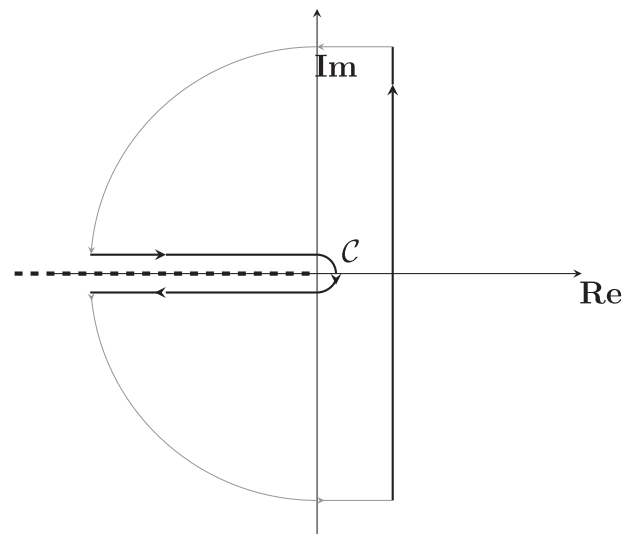

Fig. 1. Integration path.

- When  $|\arg(\gamma_i)| = \frac{\pi}{2}\alpha_i$ , the integer order component is sinusoidal; however, the fractional component exists also.
- The stability condition comes only from the integer order component. In fact, and as it is straightforward to verify, the integer order component is stable if  $\frac{\pi}{2}\alpha_i < |\arg(\gamma_i)| < \pi\alpha_i$ , and unstable if  $|\arg(\gamma_i)| < \frac{\pi}{2}\alpha_i$ . The case  $|\arg(\gamma_i)| = \frac{\pi}{2}\alpha_i$  corresponds to a critically stable system.
- Concerning to the fractional part we can verify that  $F(e^{-i\pi u}) - F(e^{i\pi u})$ , is a bounded function. Therefore, the integral in (13) is also bounded and decreases to zero as  $t$  goes to infinite, but slowly.

Applying the above considerations to the general system (1) we are led to conclude that we can decompose it in two parcels with integer and fractional behaviors, namely:

- Integer term: it has an impulse responses corresponding to linear combinations of exponentials that, in the stable case, go to zero very fast.
- Fractional term: they are long memory systems that exist always even there are no poles as when arguments of the pseudo-polynomial roots have absolute values greater than  $\pi\alpha$ , where  $\alpha$  is the corresponding derivative order smaller than 1.

**Example 5.** Consider the basic element

$$F(s) = \frac{s^{0.2}}{(s^{1/\sqrt{2}} - \gamma_1)((-2 + i)s^{1/\sqrt{2}} + \gamma_1 s^{0.51})}$$

The Figs. 2–5 illustrate the behaviour of the integer and fractional solutions for poles in both sides of the stability threshold:  $\arg(\gamma_1) = 0.71\frac{\pi}{2}$  and  $\arg(\gamma_1) = 0.69\frac{\pi}{2}$ , with  $|\gamma_1| = 1$ .

As expected, the fractional part does not change its behaviour: it is always stable. This is in agreement with the results in [11]. The instability and oscillation comes from the integer part.

**Theorem 5.** The result stated in (13) can be generalized for any TF as in (1). Let  $\Gamma_p = \{\gamma_j : -\pi\alpha_j < \arg(\gamma_j) \leq \pi\alpha_j, j = 1, 2, \dots\}$ , be the set of the poles of the TF (of course, subset of the pseudo-poles). Then

$$h(t) = \sum_{\gamma_i \in \Gamma_p} A_i e^{\gamma_i^{1/\alpha_i} t} \varepsilon(t) + \frac{1}{2\pi i} \int_0^\infty [H(e^{-i\pi u}) - H(e^{i\pi u})] e^{-ut} du \cdot \varepsilon(t).$$

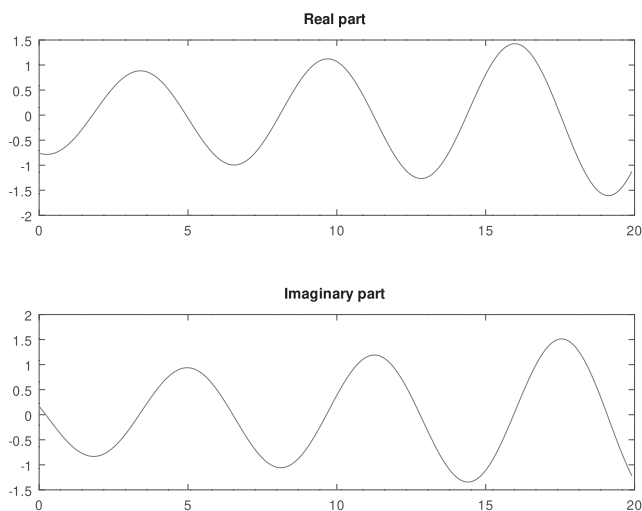

Fig. 2. Integer part  $\arg(\gamma_1) = 0.69\frac{\pi}{2}$ .

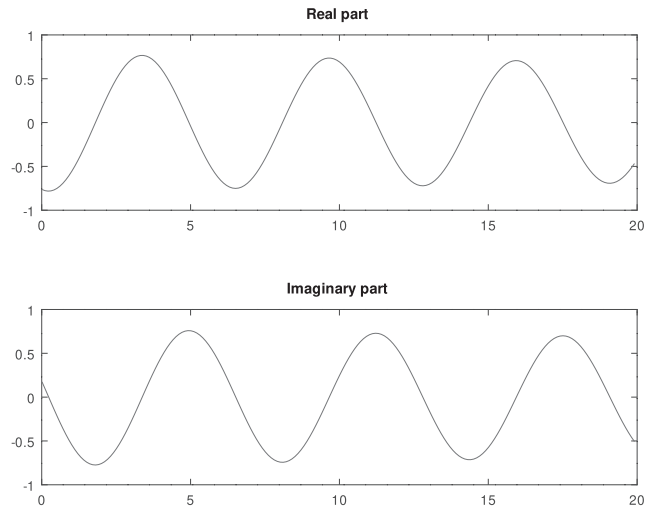

Fig. 3. Integer part  $\arg(\gamma_1) = 0.71\frac{\pi}{2}$ .

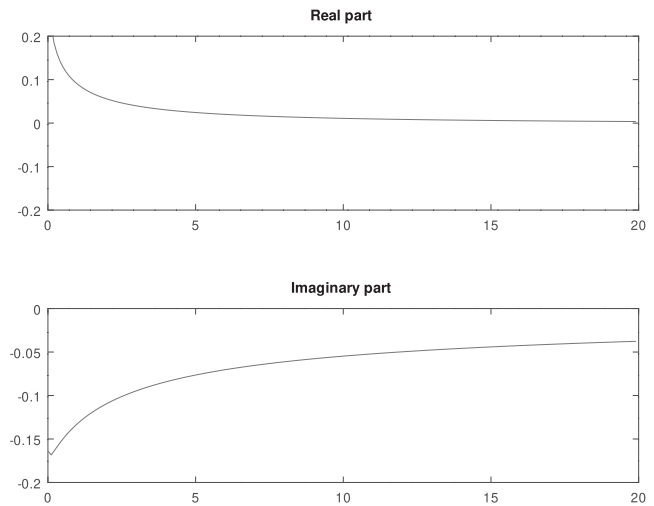

Fig. 4. Fractional part  $\arg(\gamma_1) = 0.69\frac{\pi}{2}$ .

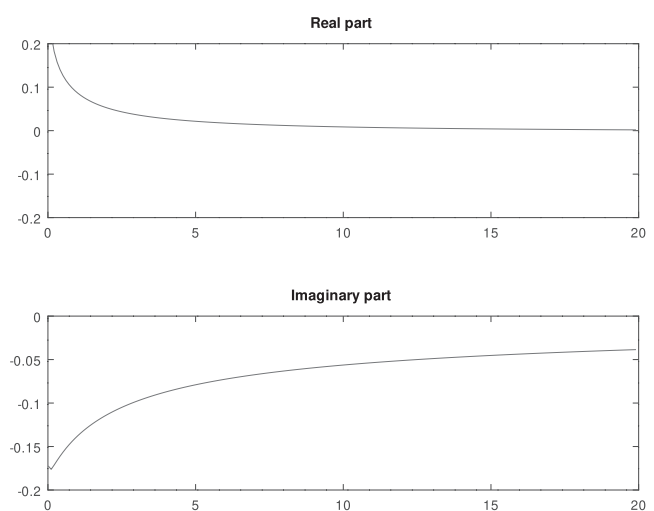
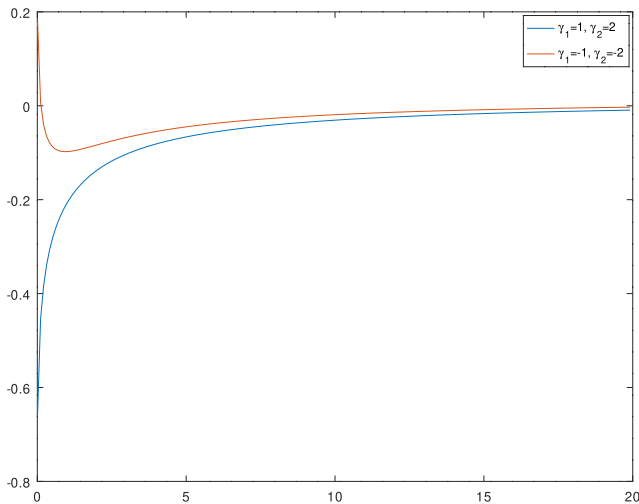

Fig. 5. Fractional part  $\arg(\gamma_1) = 0.71\frac{\pi}{2}$ .



**Fig. 6.** Fractional parts of the impulse responses of systems  $H(s) = \frac{s^2}{(s^2 \pm 1)(s^2 \pm 2)}$ .

The proof is not very difficult to obtain from the above results (see [3]).

In Fig. 6 we depict the fractional parts of the response of the system in Example 2 and another one resulting from it with the substitutions +1 for  $-1$  and  $+2$  for  $-2$ . As seen, the behaviour is similar, at least for large values of  $t$ .

## Conclusions

In this paper a study of non-commensurate fractional linear systems was done proposing a methodology similar to the one followed in the commensurate case. For it a partial fraction decomposition was obtained using a recursive procedure. Each partial fraction was inverted in two different ways: a Mittag-Leffler like procedure and an integer/fractional decomposition. Some examples were presented to illustrate the proposed approach.

## Declaration of Competing Interest

The authors have declared no conflict of interest.

## Compliance with Ethics Requirements

This article does not contain any studies with human or animal subjects.

## Acknowledgments

This work was funded by Portuguese National Funds through the FCT – Foundation for Science and Technology under the project UIDB/00066/2020. The second author was supported by Autonomous University of Mexico City (UACM) under the project P1-CCyT-2019-15.

## References

- [1] Bengochea G, Ortigueira M, Verde-Star L. Operational calculus for the solution of fractional differential equations with noncommensurate orders. *Math Methods Appl Sci* 2019.
- [2] Hcheichi K, Bouani F. Comparison between commensurate and non-commensurate fractional systems. *Int J Adv Comput Sci Appl (IJACSA)* 2018;9(11).
- [3] Henrici P. Applied and computational complex analysis, vol. 2. Wiley-Interscience; 1991.
- [4] Herrmann R. Fractional calculus: an introduction for physicists. Singapore: World Scientific Publishing; 2011.
- [5] Kilbas A, Srivastava H, Trujillo J. Theory and applications of fractional differential equations, vol. 204. Amsterdam: North-Holland Mathematics Studies, Elsevier; 2006.
- [6] Machado J. And I say to myself: what a fractional world!. *Fract Calculus Appl Anal* 2011;14(4):635–54.
- [7] Machado J, Kiryakova V. The chronicles of fractional calculus. *Fract Calculus Appl Anal* 2017;20(2):307–36.
- [8] Magin R. Fractional calculus in bioengineering. Redding: Begell House Inc.; 2006.
- [9] Magin R, Ortigueira M, Podlubny I, Trujillo J. On the fractional signals and systems. *Signal Process* 2011;91(3):350–71.
- [10] Ortigueira M. Fractional calculus for scientists and engineers. Springer; 2011.
- [11] Ortigueira M, Machado T, Rivero M, Trujillo J. Integer/fractional decomposition of the impulse response of fractional linear systems. *Signal Process* 2015;114:85–8.
- [12] Ortigueira M, Trujillo J, Martynuk V, Coito F. A generalized power series and its application in the inversion of transfer functions. *Signal Process* 2015;107:238–45.
- [13] Podlubny I. Fractional differential equations: an introduction to fractional derivatives, fractional differential equations, to methods of their solution and some of their applications. Academic press; 1999.
- [14] Ross B. Fractional calculus. *Math Magaz* 1977;50(3):115–22.
- [15] Samko S, Kilbas A, Marichev O. Fractional integrals and derivatives: theory and applications. Amsterdam: Gordon and Breach Science Publishers; 1993.
- [16] Tarasov V. Fractional dynamics: applications of fractional calculus to dynamics of particles, fields and media. Nonlinear physical science. Beijing, Heidelberg: Springer; 2010.