



Since January 2020 Elsevier has created a COVID-19 resource centre with free information in English and Mandarin on the novel coronavirus COVID-19. The COVID-19 resource centre is hosted on Elsevier Connect, the company's public news and information website.

Elsevier hereby grants permission to make all its COVID-19-related research that is available on the COVID-19 resource centre - including this research content - immediately available in PubMed Central and other publicly funded repositories, such as the WHO COVID database with rights for unrestricted research re-use and analyses in any form or by any means with acknowledgement of the original source. These permissions are granted for free by Elsevier for as long as the COVID-19 resource centre remains active.



Avian reovirus sigma C enhances the mucosal and systemic immune responses elicited by antigen-conjugated lactic acid bacteria

Kuan-Hsun Lin^a, Ai-Ping Hsu^{a,b}, Jui-Hung Shien^a, Tien-Jye Chang^a, Jiunn-Wang Liao^c, Jeng-Rung Chen^a, Chuen-Fu Lin^{d,**}, Wei-Li Hsu^{e,*}

^a Department of Veterinary Medicine, College of Veterinary Medicine, National Chung Hsing University, 250 Kuo Kuang Road, Taichung 402, Taiwan

^b Animal Health Research Institute, Council of Agriculture, 376 Chung-Cheng Road, Tamsui, Taipei 251, Taiwan

^c Graduate Institute of Veterinary Pathobiology, National Chung Hsing University, Taichung 402, Taiwan

^d Department of Medical Laboratory Science and Biotechnology, Central Taiwan University of Science and Technology, Taiwan

^e Graduate Institute of Microbiology and Public Health, College of Veterinary Medicine, National Chung Hsing University, 250 Kou Kuang Road, Taichung 402, Taiwan

ARTICLE INFO

Article history:

Received 4 November 2011

Received in revised form 29 March 2012

Accepted 10 April 2012

Available online 21 April 2012

Keywords:

Mucosal immunity

LAB

IBV

Spike protein

Reovirus

Sigma C

M cells

ABSTRACT

Mucosal surfaces are common sites of pathogen colonization/entry. Effective mucosal immunity by vaccination should provide protection at this primary infection site. Our aim was to develop a new vaccination strategy that elicits a mucosal immune response. A new strain of *Enterococcus faecium*, a non pathogenic lactic acid bacteria (LAB) with strong cell adhesion ability, was identified and used as a vaccine vector to deliver two model antigens. Specifically, sigma (σ) C protein of avian reovirus (ARV), a functional homolog of mammalian reovirus σ 1 protein and responsible for M-cell targeting, was administered together with a subfragment of the spike protein of infectious bronchitis virus (IBV). Next, the effect of immunization route on the immune response was assessed by delivering the antigens via the LAB strain. Intranasal (IN) immunization induced stronger humoral responses than intragastric (IG) immunization. IN immunization produced antigen specific IgA both systemically and in the lungs. A higher IgA titer was induced by the LAB with ARV σ C protein attached. Moreover, the serum of mice immunized with LAB displaying divalent antigens had much stronger immune reactivity against ARV σ C protein compared to IBV-S1. Our results indicate that ARV σ C protein delivered by LAB via the IN route elicits strong mucosal immunity. A needle-free delivery approach is a convenient and cost effective method of vaccine administration, especially for respiratory infections in economic animals. Furthermore, ARV σ C, a strong immunogen of ARV, may be able to serve as an immunoenhancer for other vaccines, especially avian vaccines.

© 2012 Elsevier Ltd. All rights reserved.

1. Introduction

Mucous membranes constitute the largest interface between the body and the external environment and serve as a physical barrier that prevents the entry and dissemination of infectious pathogens. In addition, it contains immunocompetent cells that are required for the generation of antigen-specific mucosal immunity, the crucial immunological defense against invading microorganisms.

Microfold (M) cells, located in follicle-associated epithelium (FAE), transport the antigens, which include both soluble proteins and infectious agents, from the intestinal and respiratory tract lumen to the mucosa-associated lymphoid tissues (MALT),

namely Peyer's patches, and nasopharynx-associated lymphoid tissue (NALT), respectively [1,2]. In the MALT, dendritic cells process and present antigens to T cells that in turn preferentially induce the production of secretory IgA (SIgA) at mucosal surface [3]. This IgA effectively neutralizes and prevents attachment and internalization of pathogens into host cells. Hence, the elicitation of mucosal immunity is critical when developing vaccines against infectious pathogens that are transmitted through mucosal sites.

Vaccine strategies that target mucosal immunity have many advantages; these include the capacity to elicit both systemic and mucosal immune responses together with improved accessibility, safety, and cost-effectiveness because the delivery is needle-free [4]. Several lines of evidence have indicated that induction of adequate mucosal protective immune response requires the aid of adjuvants. At present, the most effective mucosal adjuvants are Cholera toxin and *Escherichia coli* lymphotoxin [5]; however, considering their potential toxicity, these bacterial toxins are not acceptable for clinic use [6]. Lactic acid bacteria (LAB), which are generally classified as GRAS (Generally Recognized As Safe)

* Corresponding author. Tel.: +886 4 228 40694; fax: +886 4 22852186.

** Corresponding author. Tel.: +886 4 223 91647x3955.

E-mail addresses: cflin@ctust.edu.tw (C.-F. Lin), wlhsu@dragon.nchu.edu.tw (W.-L. Hsu).

organisms, are traditionally used in the food industry. Recently, the potential application of LAB as vehicles for the expression and delivery of model antigens to mucosal surfaces has been extensively investigated [7–10]. Bermudez-Humaran et al., showed that mice intranasally administered with *Lactococci lactis* (LL), having the E7 antigen of human papillomavirus type 16 (LL-E7) anchored to the cells together with the secretory form of interleukine-12 (LL-IL-12), induced an E7-specific immune response and provided therapeutic effects [7,8]. Cortes-Perez has further demonstrated that simultaneous immunization of the LL-E7 and LL-IL-12 strains via the intranasal route is able to elicit higher specific immune responses and more potent anti-tumor effects than that via the intragastric route [11]. In addition, Mohamadzadeh et al., reported that co-culture with *Lactobacillus* promotes DC maturation and up-regulates expression of IL-12 and IL-18, but not IL-10. These results suggest that LAB regulate T cell responses and target them toward the T helper 1 pathway [12]. Hence, LAB strains act not only as a delivery vehicle, but also as an intrinsic adjuvant during vaccination. Nevertheless, the effect of LAB on immunomodulation may vary dependent with the LAB species or strain [13]. Thus the routes of immunization and differences in the intrinsic adjuvanticity of LAB strains need to be considered when planning an immunization strategy. In addition to *Lactobacillus*, the probiotic effect of *Enterococcus faecium* (*E. faecium*) has been demonstrated [14–16]. It is worthy of noting that unlike most of LAB, the *Enterococcus* genus is not considered as “GRAS”. For safety concern and to avoid antibiotic resistant gene transmission, a case-by-case evaluation of pathogenicity and antibiotics resistance profiles is required [17].

Avian infectious bronchitis virus (IBV) is a member of group 3 of the coronaviruses and is a highly contagious disease of chickens [18,19]. The spike glycoprotein, which is involved in cell attachment, is an immunodominant protein that carries epitopes that produce virus-neutralizing antibodies [20]. Previously, Lee et al., found that intranasal and oral immunization of mice with *Lactobacillus casei* displaying the spike protein of SARS-coronavirus on its surface elicited protective systemic and mucosal immune responses against SARS pseudovirus [9]. Based on this finding, a previously defined antigenic epitope of the Spike protein of the IBV Taiwan local strain (TW1) was selected as one of the model antigens. This was used for the induction of the antigen-specific antibodies and evaluated in current study.

Avian reoviruses (ARV) are classified into the orthoreovirus genus of the family *Reoviridae*. Sigma (σ) C protein, a component of the outer capsid layer of the ARV, is responsible for attachment to the host cell membrane [21] and can induce high levels of type-specificity neutralization antibodies [22]. Structure-based sequence alignment of the ARV sigma C and mammalian reovirus (MRV) type 3 sigma 1 have indicated the presence of heptad repeats and a triple alpha-helical coiled-coil structure in N-terminal region [23]. In addition, crystallographic studies found that the carboxy-terminal globular domain of ARV sigma C has a similar overall topology to that of MRV type 3 sigma 1. It has been shown that MRV sigma 1 protein recognizes the receptor of M cells (α -2-3 linked sialic acid) that facilitates penetration of antigens into intestinal Peyer's patches [24]. Mishra et al. further reported that encapsulation of hepatitis B surface antigen by nanocarriers or liposomes with M-cell targeting ligands (lectins, including *Ulex europaeus agglutinin* 1; UEA-1) promotes intestinal uptake by M-cells, enhances antibody production and increases cellular immune responses [25,26]. As immunomodulation of ARV sigma C has not yet been reported, we investigated whether ARV sigma C protein has a similar effect as MRV sigma 1 on the enhancement of mucosal immunization.

In this study, LysM of AcmA', the autolysin of *Lactococcus lactis*, which can exogenously bind to the peptidoglycan of LAB [27], was chosen as the anchor molecule for docking each of the desired antigenic protein onto the LAB surface. The two model antigens,

IBV-spike and ARV-sigma C, were expressed as a AcmA' tag fused at the C-terminal end. The display of recombinant proteins on the LAB surface was confirmed and the immune response induced by the antigen-displaying LAB was evaluated using an animal model.

2. Materials and methods

2.1. Bacterial strains and growth conditions

The lactic acid bacteria (LAB), namely three *Enterococcus faecium* (*E. faecium*) strains, were obtained, one from the Food Industry Research and Development Institute, Taiwan, (ATCC-6057) and two being isolated from pig intestine flora (58a-1, 63b-2). These were cultured on *Lactobacilli* MRS broth (Difco™ Detroit, Mich., USA) at 37 °C without shaking. To quantify the bacteria, the *E. faecium* was grown to logarithmic phase, collected by centrifugation, and then washed three times with phosphate buffer saline (PBS). The initial concentration of the bacteria was determined by spectrophotometry at OD 600 nm. The number of bacteria in each sample was verified by pour-plate assay using Ragoza agar plate (Difco™ Detroit, Mich., USA) and ten-fold serial dilution. Finally, the LAB were diluted in 1×PBS at a concentration of 10¹⁰ colony forming units (CFU)/ml. *Escherichia coli* (*E. coli*) Top10 (Invitrogen) and BL21 (DE3) (Novagen), which were used for plasmid amplification and protein expression, respectively, and were grown in LB medium with shaking at 37 °C.

2.2. Cell culture

The intestine cell line Int 407 (ATCC: CCL-6) was cultured using BME (Basal medium Eagle in Earle's BSS) with 10% fetal bovine serum (FBS), penicillin 100 U/ml, and streptomycin 100 µg/ml.

2.3. Animals

Female BALB/c mice, 5–8 weeks old, were purchased from the National Laboratory Animal Center (Taiwan). All experiments were performed in accordance with the University Guidelines.

2.4. Plasmid construction

To generate the recombinant proteins for immunization, plasmid expressing antigenic protein fused with the AcmA' protein, which serves as an anchoring protein onto Gram positive bacteria such as lactic acid bacteria (LAB) [28], were constructed in two steps. Initially, AcmA' fragment was obtained by PCR from the DNA of *L. lactis* (cremoris SK11) using the primer sets (AcmA'-F: CGACAAGCTTGACACGGACGGAGCTTCTC, and AcmA'-R: GGTGCTCGAGTGAACCACCTGAATTTGTA), which were designed based on sequences published in GenBank (accession number: AF036720). The thermal cycling conditions were: 94 °C (3 min) followed by 35 cycles of denaturation (94 °C, 30 s), annealing (55 °C, 45 s), and extension (72 °C, 1 min), and finished with a final extension (72 °C, 3 min). The PCR product had the expected size of 261 base pairs (bp) and was then digested with *Hind* III and *Xho* I restriction enzymes for subcloning into the prokaryotic expression vector pET24a. The resulting plasmid was named AcmA'-pET24a.

Based on a previous report [29], an epitope consisting of amino acids residues 235–302, which are highly conserved in S1 subunit of infectious bronchitis virus (IBV) spike (S) protein and show antibody neutralizing activity, was chosen for use in this study. Primers were designed to amplify the S1 sub-fragment (residues 235–302) of the IBV TW1 strain (GenBank accession number: DQ646405) by PCR. The primer sequences used were: IBV-S1-F: TGCTAGCTAGCCAATATAATACTGG and IBV-S1-R: AAAATGTCGACAAGCTTTCTGAGCTG. A plasmid IBV-S-pTA

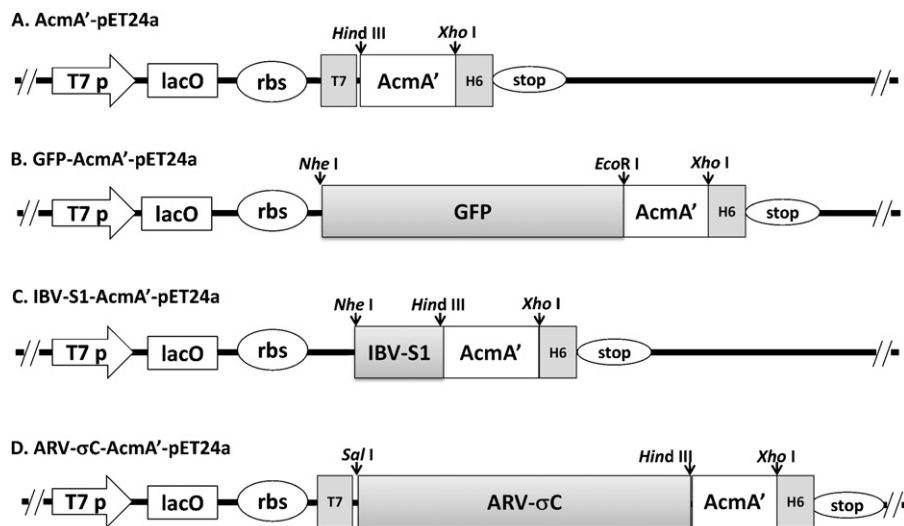

Fig. 1. Schematic illustration of constructs expressing AcmA'-fusion proteins. Plasmid AcmA'-pET24a contains fragments of Lys motif domain (AcmA'; 261 bp) with bacteria cell wall-anchored ability upstream of the hexahistidine tag (H6). The DNA fragments of the other three proteins for displaying on LAB, namely GFP (813 bp), the IBV-S1 epitopes (204 bp), and the ARV-sigma C coding region (978 bp) were inserted upstream of AcmA'. The expression of these recombinant proteins is under the control of the T7 RNA polymerase promoter (T7 p). Restriction enzymes used for cloning and other cis-elements on vector backbone are also indicated, such as the lac operator (lacO), the ribosome binding site (rbs) and the stop codon (stop).

containing the whole S1 coding region of IBV was used as template. The thermal cycling conditions were: 94 °C (3 min) followed by 35 cycles of denaturation (94 °C, 30 s), annealing (55 °C, 1 min), and extension (72 °C, 1 min), and ended with a final extension (72 °C, 3 min). The resultant PCR product (232 bp) was digested with *Nhe* I and *Hind* III restriction enzymes, which are present in the primers, and then the fragment was subcloned into the expression vector, AcmA'-pET24a. The resulting plasmid was named IBV-S1-AcmA'-pET24a.

Another antigenic protein, the full length of sigma C of avian reovirus (ARV), was amplified from the plasmid σ C-pSTBlue-1 (a gift from Dr. LH Lee in Department of Veterinary Medicine, National Chung-Hsing University, accession number: AF204948) and cloned into AcmA'-pET24a expression vector by PCR. The primers used were: ARV- σ C-F: ATAGTGTTCGACATATGGCCGGTCTC and ARV- σ C-R: GCGCCAAAGCTTCGGTGTTCGATGC. The amplification conditions were: 94 °C (3 min) followed by 35 cycles of denaturation (94 °C, 30 s), annealing (55 °C, 45 s), and extension (72 °C, 1 min), followed by a final extension (72 °C, 3 min). After digestion with *Sal* I and *Hind* III restriction enzymes, the PCR fragment (1002 bp) was introduced into the vector AcmA'-pET24a. The resulted expression plasmid was designated ARV- σ C-AcmA'-pET24a.

The green fluorescent protein (GFP) was used to determine anchoring efficiency. The GFP coding region (723 bp) was obtained by digesting the plasmid pQBI25-fPA (Q-BIOgene, Inc. Morgan Irvine, CA, USA) with *Nhe* I and *Eco*R I restriction enzymes. The GFP fragment was then introduced into the vector AcmA'-pET24a, which had been linearized with the same enzymes. This expression plasmid was designated GFP-AcmA'-pET24a. The authenticity of all the PCR products was confirmed by automated sequencing after the clones were initially checked by restriction enzyme digestion. The map and structure of the various plasmids expressing the different recombinant antigenic proteins are presented in Fig. 1.

2.5. Recombinant protein expression and purification

The various plasmids were transformed into *Escherichia coli* strain BL21 (DE3). All the recombinant proteins were expressed under induction of 0.8 mM IPTG at 16 °C for 24 h. Initially, bacterial cell pellets were dissolved in 1/10 volume of binding buffer without denaturing agent (0.01 M imidazole, 0.5 M NaCl, 0.05 M Tris-HCl,

200 μ g/mL lysozyme) followed by freeze-thawing cycles and then sonication. After centrifugation (fractionation) at 13,000 rpm for 15 min at 4 °C, the supernatant of crude extract containing soluble GFP-AcmA' was obtained. Since the majority of IBV-S1-AcmA' and ARV- σ C-AcmA' were expressed as insoluble form, the bacteria pellet after fractionation was then dissolved in lysis buffer (0.01 M imidazole, 0.5 M NaCl, 0.05 M Tris-HCl, 6 M urea). As all the recombinant proteins were expressed with 6-histidine tag at C-terminus, after fractionation the recombinant proteins were further purified by metal affinity chromatography according manufacturer protocol (Pharmacia). In brief, the bacteria crude extract was loaded into column packed with Ni-NTA sepharose and incubated for 2 h at room temperature with rotation, followed by 5 times of washes with buffer (0.02 M imidazole, 0.5 M NaCl, 0.05 M Tris-HCl), and then eluted using a buffer containing a high concentration of imidazole (100, or 400 mM). After step-wise dialysis against PBS (0.02 M phosphate, 0.15 M NaCl) containing gradually decreased concentration of urea at 4 °C to remove the imidazole, the protein concentration was determined by Bradford method (Bio-Rad). For purification of denatured form of recombinant protein, all the buffers contained 6 M urea. The contaminated endotoxin level of the recombinant proteins was measured by Pyrotell Gel-clot Endotoxin Testing followed the manufacturer's description (Cat No. #G5250, Associates of CAPE COD, Woods Hole, USA).

2.6. Preparation and confirmation of AcmA' fusion protein anchorage onto the LAB *E. faecium*

Initially, the binding capacity of AcmA' fusion proteins to the bacteria surface was determined. To do so, the LAB *E. faecium*, 10⁹ CFU, was incubated with different concentrations (0, 5, 10, 20 and 50 μ g/tube) of the GFP-AcmA' protein by shaking with 200 rpm at 30 °C for 3 h followed by centrifugation for 10 min at 6000 rpm. Subsequently, the supernatant and bacteria pellet were fractionated and resolved by SDS-PAGE. Binding efficiency was evaluated by the ratio of AcmA' fusion protein present in supernatant (free form of AcmA' fusion protein) and in bacteria pellet anchored to AcmA' fusion protein. Additionally, bacteria anchored with GFP-AcmA' fusion proteins were directly observed by fluorescent microscopy, and the proteins detached from the bacterial surface were separated by SDS-PAGE.

2.7. Whole-cell enzyme-linked immunosorbent assay (ELISA)

Whole-cell ELISA was conducted following a previous protocol [28]. Briefly, the LAB *E. faecium*, 10^9 CFU only and LAB mixed with 20 μg of AcmA' fusion protein (IBV-S1 and ARV- σC , in 200 μl volume) were incubated for 3 hours at 30 °C. The bacteria were then washed three times with PBS, and incubated with 5% BSA in PBS for 30 min at room temperature to block non-specific binding. After washing with PBS, the bacteria pellet was resuspended in 500 μl of 1:2000 diluted primary anti-His antibody solution (*AbD Serotec., Kidlington, UK*) and incubated for 2 h at room temperature. The bacteria were then washed three times with PBS before incubation with the secondary antibody, horseradish peroxidase (HRP)-conjugated anti-mouse antibodies (Jackson ImmunoResearch Laboratories, Inc., West Grove, PA USA) diluted at 1:2000 in PBST (0.02 M phosphate, 0.15 M NaCl, 0.05% Tween-20) at room temperature for 1 h. The bacteria were then washed three times with PBS and finally resuspended in 200 μl of PBS. Then, 50 μl of the suspension was loaded into the wells of an ELISA plate, followed by 50 μl of ABST substrate (KPL, Kirkegaard & Perry Laboratories, Inc., Gaithersburg, MD USA). The plate was then incubated at room temperature for 10 min before the optical density at 405 nm (OD405) was measured.

2.8. SDS-PAGE and Western blot analysis

Proteins were resolved by 10% or 12.5% SDS-PAGE and electrotransferred to nitrocellulose membrane using Mini Protein III equipment (Bio-Rad Laboratories, Richmond, CA, USA). Membranes were blocked in PBST containing 5% dried skimmed milk and incubated with anti-His tag antibody (*AbD Serotec., Kidlington, UK*) in PBST for overnight at 4 °C. After several times of PBST buffer wash, the filter was incubated with 1:10,000 diluted secondary antibody, goat anti-mouse IgG conjugated HRP (Jackson ImmunoResearch Laboratories, Inc., West Grove, PA, USA) for one hour at room temperature. After PBST wash to remove the unbound antibodies, the signal was detected using TMB reagent (KPL, Kirkegaard & Perry Laboratories, Inc., Gaithersburg, MD, USA).

2.9. Absorption of LAB on intestine cells (Int 407)

The monolayer Int 407 cells (10^4 /well) were cultured in 24-well plate without antibiotics. Prior to absorption, *E. faecium* were washed with PBS twice and resuspended in BME medium at concentration of 1×10^8 CFU/ml. Subsequently, 100 μl of bacteria were added to the cell monolayer with rocking every 15 min. After 2 h, the cells were washed three times with PBS, fixed with 10% formaldehyde; this was followed by Gram staining and observation by microscopy.

2.10. Display of antigens on LAB surface

For one unit dose of antigen anchored LAB, 10^9 CFU of *E. faecium* was incubated with 20 μg of each purified protein: IBV-S1-AcMA', with or without ARV- σC -AcMA' protein at 30 °C for 3 h. Prior to immunization, the binding of the AcMA'-antigen fusion protein on LAB was confirmed by fractionation. After centrifugation (10 min at 6000 rpm), the supernatant containing the unbound AcMA' fusion proteins and the bacteria pellet were separated. The binding efficiency was then evaluated by SDS-PAGE and whole-cell ELISA.

2.11. Immunization

BALB/c mice, aged eight weeks, were randomly assigned to six treatment groups with five mice in each group. Mice in group 1–3 were immunized via the intragastric (IG) route, whereas mice in

Group 4–6 were immunized via the intranasal (IN) route. Each group of mice was immunized by one of three different regimens. These were: (1) LAB without recombinant protein; (2) LAB anchored with IBV S1-AcMA' protein; and (3) LAB anchored with IBV S1-AcMA' protein in combination with ARV- σC -AcMA' protein. The IG group mice were immunized with 5 units antigenic protein (5×10^9 CFU LAB anchored 100 μg of each recombinant protein) in 500 μl volume, while the IN group were immunized with 2 units antigenic protein (2×10^9 CFU LAB anchored 40 μg of each recombinant protein) in 20 μl volume. The groups of mice were initially immunized on day 0 and this followed by three boosters at two-week interval. To eliminate the influence of other environment bacteria on the immune responses derived from LAB immunization, the mice were given drinking water containing gentamicin (50 $\mu\text{g}/\text{ml}$) for three days before the immunization and throughout the experiment.

2.12. Sample collection

Blood and bronchoalveolar lavage (BAL) were collected from each mouse. Blood samples were obtained from orbital vascular plexus with heparin supplement. After centrifugation, the plasma was transferred to a new tube and stored at -20 °C until use. BAL samples were collected using a modification of the method of Bergeron et al. [30]. This was as follows. To collect the BAL, a small incision was made in the trachea to insert of a small tube connected to a syringe. Lung washes were performed by injecting 1 ml PBS into the lung followed by aspiration of the lavage fluid. BAL fluid was centrifuged at 1200 rpm for 10 min, and the supernatant was frozen at -20 °C until testing.

2.13. Detection of antibodies by ELISA

Antibody responses to the IBV epitope were analyzed by ELISA. Nunc-Immuno 96-well plates (Nunc) were coated with recombinant IBV-S1-AcMA' fusion protein (100 μl of the 200 ng protein in sodium carbonate buffer, pH 9.6, per well). After overnight incubation at 4 °C, the plates were washed three times with PBST. Nonspecific protein binding sites were blocked with PBST buffer containing 5% skimmed milk. For antibody detection, plasma and BAL samples, as primary antibody, were diluted in PBS with ratios of 1:50, or 1:10, respectively. Then, goat anti-mouse IgG (Jackson ImmunoResearch Laboratories, Inc., West Grove, PA USA) and IgA (Sigma-Aldrich, Inc., Saint Louis, MO, USA) conjugated with HRP (diluted in 1:2000) were used as secondary antibodies. ABTS substrate (KPL, Kirkegaard & Perry Laboratories, Inc., Gaithersburg, MD, USA) was added and the absorbance was detected at OD 405 nm.

2.14. Statistical analysis

Data are expressed as means \pm SEM. Significant differences were pinpointed by Student's *t*-test Welch's correction and analysis of variance. Immunization group and antibodies response were used as factors when testing for statistical significance in effect by one-way ANOVA. The analysis results were generated by the GraphPad statistical package analysis tool (GraphPad Software, San Diego, CA).

3. Results

3.1. Construction of plasmids expressing antigen-AcMA' fusion proteins

To develop lactic acid bacteria (LAB) as a vaccine carrier, AcMA' protein was used as a protein anchor to display the antigen on the

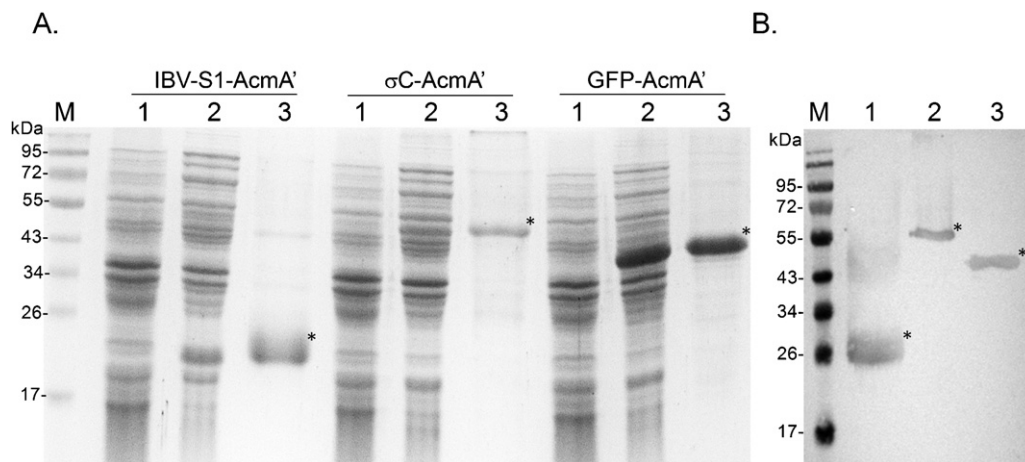

Fig. 2. Detection of expression of AcmA' fusion proteins by SDS-PAGE and Western blot analysis. Expression of IBV-S1-AcMA', ARV- σ C-AcMA', and GFP-AcMA' was induced by IPTG (lane 2), purified by Ni-NTA affinity chromatography (Lane 3) and separated by SDS-PAGE (A). Their identity was confirmed by Western blot analysis using His-tag antibody (B). Lane 1: non-induction; M: protein size marker (Fermentas, #SM0671).

surface of *E. faecium*. Several plasmids were constructed to produce chimera proteins, each of which had AcmA' protein expressed at C-terminal of the antigenic protein. First, a construct AcmA'-pET24a containing a fragment of the bacterial cell wall-binding protein AcmA' was generated (Fig. 1A). For direct observation of protein displayed on LAB by microscopy, a GFP coding region was inserted upstream of AcmA' (Fig. 1B). In addition immunogenic proteins of two avian viruses were used to evaluate the possibility of developing LAB as a divalent vaccine carrier. To do so, two PCR fragments containing the partial coding regions of viral envelope proteins, the Spike protein of IBV and the σ C protein of ARV, were amplified by PCR and cloned into AcmA'-pET24a and the resulting plasmids were designated IBV-S1-AcMA'-pET24a, and ARV- σ C-AcMA'-pET24a, respectively (Fig. 1C and D). The schematic representation of the cis-elements and the structure of the plasmids that express recombinant antigens are illustrated in Fig. 1.

3.2. Preparation of purified the AcmA' fusion proteins

Expression of recombinant proteins was driven by the T7 RNA polymerase under IPTG induction in *E. coli* (strain BL21). All constructs successfully produced antigenic proteins at various levels (lane 2, Fig. 2A). Recombinant proteins were purified by Ni-NTA chromatography following the manufacturer's methodology (Pharmacia). After Ni-NTA affinity purification, the IBV-S1-AcMA', ARV- σ C-AcMA', and GFP-AcMA' proteins with expected sizes of 25 kDa, 55 kDa, and 40 kDa, respectively, were obtained (lane 3, Fig. 2A). The purity of AcmA' fusion proteins was analyzed by SDS-PAGE (lane 3, Fig. 2A) and the identity was initially confirmed by Western blotting (Fig. 2B). Of the three recombinant AcmA' fusion proteins, GFP-AcMA' is soluble, but the other two proteins are predominately insoluble. Hence, the proteins were purified from the insoluble fraction and refolded by step-wise dialysis against PBS to remove urea.

3.3. Determination of the binding efficiency of the AcmA' fusion proteins to *E. faecium*

One of the basic requirements for the probiotic strains is capability of adherence to the intestinal epithelial cells [31]; it plays a part in their propagation in the digestive tract [32,33] and also to participate in the capacity of competitive exclusion of pathogens [34,35]. Hence, initially the adhesion capability of new *E. faecium* strains was tested on intestinal epithelial cells (Int 407)

and subsequently, the binding efficiency of AcmA'-fusion proteins onto the surface of *E. faecium* (vaccine carrier) was determined.

When cultured with an intestine cell line, one of the two new isolates, strain 58a-1 showed very weak adhesion capability (Fig. 3A, sample 4); and among the three LAB tested, *E. faecium* 63b-2 showed the greatest absorption capacity (Fig. 3A) that was then used for this study.

In order to test the binding capacity of recombinant AcmA' proteins on the LAB surface, *E. faecium* (1×10^9 CFU) were incubated with different amount of GFP-AcMA' fusion proteins (0, 5, 10, 20 and 50 μ g) for 3 h at 30 °C. Initially, we investigated whether AcmA' docked on the cell wall and displayed the antigenic protein on surface of bacteria. Incubation of various amounts of anchoring protein followed by intensive wash with PBS, the bacteria pellet was directly analyzed by fluorescent microscopy. As illustrated in Fig. 3B, in LAB binding assay, the higher amount of GFP-AcMA' used, the stronger intensity of GFP signal observed, indicating that GFP was indeed displayed on surface of LAB in a dose dependent manner.

Next, the maximal bind capacity of AcmA' fusion protein on LAB was investigated. Analysis of the fractionated protein content revealed that the majority of GFP-AcMA' fusion protein were anchored on *E. faecium* (Fig. 3C). Noticeably, some of unbound protein remained in supernatant fraction when 50 μ g of GFP-AcMA' was used for anchoring, indicating that this dose of AcmA' fusion protein had exceeded the binding capacity of 1×10^9 *E. faecium* (Fig. 3D).

3.4. Preparation of antigen-display LAB for immunization

The IBV-S1-AcMA' and ARV- σ C-AcMA' were purified under conditions with denaturant, which was removed by dialysis; therefore it is worth checking whether these two refolded AcmA' fusion proteins are able to anchor onto LAB. Whole cell ELISA and SDS-PAGE were employed to confirm the antigen display and binding efficiency of these two recombinant proteins. Based on the binding capacity results, a combination of 20 μ g of fusion protein with 1×10^9 of LAB was used (as one unit of immunization dose). After co-incubation for 3 h followed by intensive washing with PBS, the *E. faecium* bacteria were subjected to ELISA to detect antigen display. A strong reaction was observed in the wells containing the bacteria incubated with AcmA' fusion proteins, whilst the wells with untreated bacterial cells remained negative (Fig. 4A). After centrifugation, the two AcmA' fusion proteins could be detected in the cell

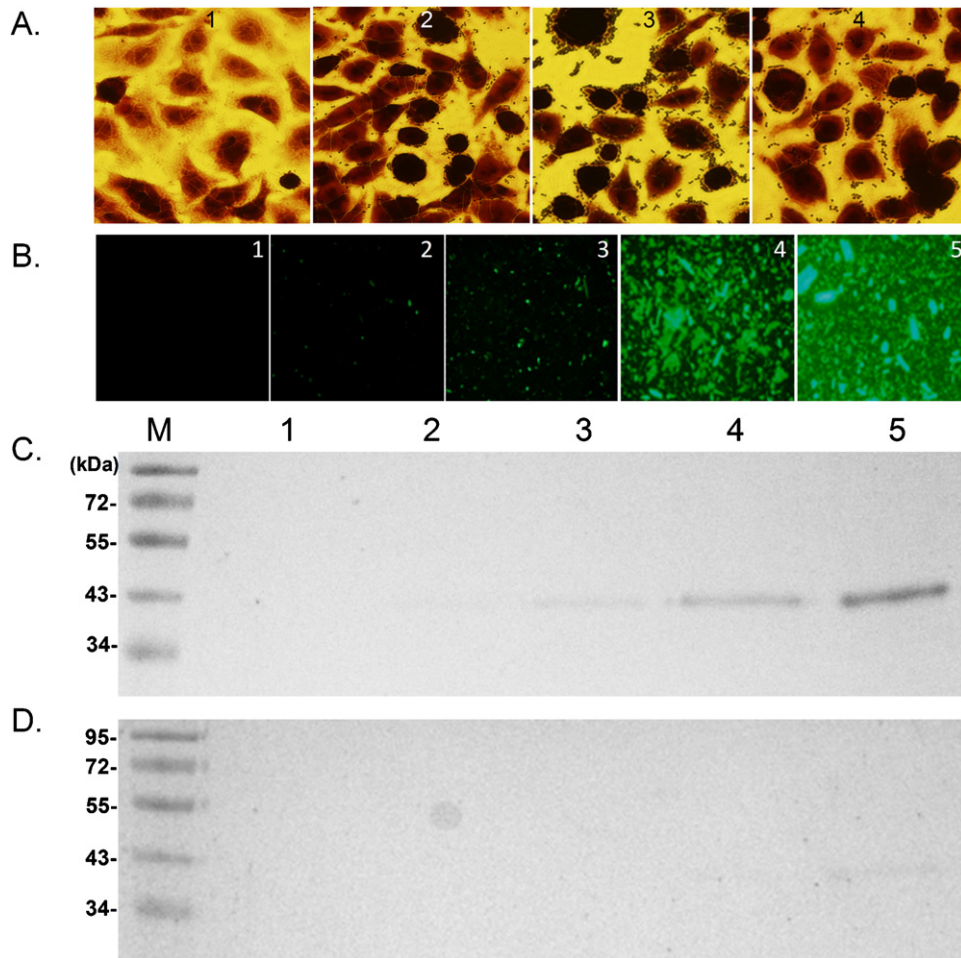

Fig. 3. The cell adhesion ability and maximal protein binding capacity of LAB. A monolayer of Int 407 cells (10^4 /well) were mixed without LAB (sample 1), or with 1×10^7 CFU of *E. faecium* (standard strain ATCC 6057) (sample 2), *E. faecium* 63b-2 (sample 3), or *E. faecium* 58a-1 (sample 4). After 2 h, the cells were thoroughly washed and fixed with 10% formaldehyde, followed by Gram staining (A). The maximum binding capacity of the AcmA' fusion protein to LAB was determined as follows. Various concentrations of AcmA'-GFP fusion protein (0, 5, 10, 20, and 50 μ g indicated as sample 1–5, respectively) were mixed with 1×10^9 CFU of *E. faecium* 63b-2 at 30 °C for 3 h followed by intensive washes with PBS. After centrifugation, the supernatant containing unbound AcmA'-GFP fusion protein was transferred to a new tube and the pellet containing the LAB anchored GFP fusion protein was directly examined by fluorescent microscopy (B). In addition, to evaluate the binding efficiency, the anchored form (C) and free form (D) of GFP fusion proteins were then analyzed with SDS-PAGE. Binding efficiency was determined by the ratio of AcmA' fusion protein present in the bacteria pellet (anchored form) (C) to that in supernatant (free form) (D).

pellets (proteins bound with LAB), but not in supernatant (free form proteins) (Fig. 4B). These results showed that AcmA' fusion proteins effectively bind to the LAB surface.

3.5. Detection of antibodies by ELISA

Next, we evaluated whether immunization with the cell surface displayed recombinant proteins on LAB was able to elicit specific antibodies production in mice. To induce mucosal immunity, antigen-anchored LAB were delivered by the intranasal (IN) and intragastric (IG) routes. The immunization protocol is illustrated in Fig. 5A.

Mice from each group received either mock LAB (negative control), LAB displaying IBV-S1-AcmA' alone or LAB displaying a combination of IBV-S1-AcmA' with ARV- σ C-AcmA'. Antibody induction in serum samples was compared by ELISA. Since AcmA, the anchoring protein present in each antigens displayed on LAB, poorly reacted with tested sera (data not shown), IBV-S1-AcmA' fusion protein, was used as target protein to evaluate the IBV-S1 antigen-specific immune responses induced by immunization.

The results showed that mice immunized with LAB anchored with IBV-S1-AcmA' in combination with or without ARV- σ C-AcmA' by both IG and IN routes induced specific anti-IBV-S1 IgG antibodies

(Fig. 5B and 4C, respectively), while no detectable specific antibody was observed in sera collected from animals that received the mock LAB. For the IG group, on day 49, the antibody titers in mice immunized with LAB anchored with ARV- σ C was significantly higher than that of mock LAB and LAB anchored IBV-S1 only (LAB only: $p=0.03$, LAB anchored with IBV-S1: $p=0.05$, analyzed by Student *t* test) (Fig. 5B). For the IN group, compared with the control mice, the induction of antibody in mice immunized with LAB displaying IBV-S1 fusion protein alone was not significant, but a significant increase in antibody level was observed in mice immunized with IBV-S1 in combination with ARV- σ C; significantly higher than that of LAB only ($p=0.03$) and LAB anchored with IBV-S1 ($p=0.01$) on day 35 (Fig. 5C). An increase in IgG response as immunization proceeded was observed. Overall, the ELISA results indicated that fusion protein anchored LAB were able to triggered systemic immune reactions in the mice when the two different immunization routes were used.

After the final booster, the mice were sacrificed and both sera and bronchoalveolar lavage (BAL) samples were collected to allow detection of antigen-specific IgG and IgA, which indicate systemic and mucosal immune responses, respectively. Overall, immunization via the IG route gave a much higher level of IgG in both the BAL and the sera, while the IgA induction was very low (Fig. 6A and C).

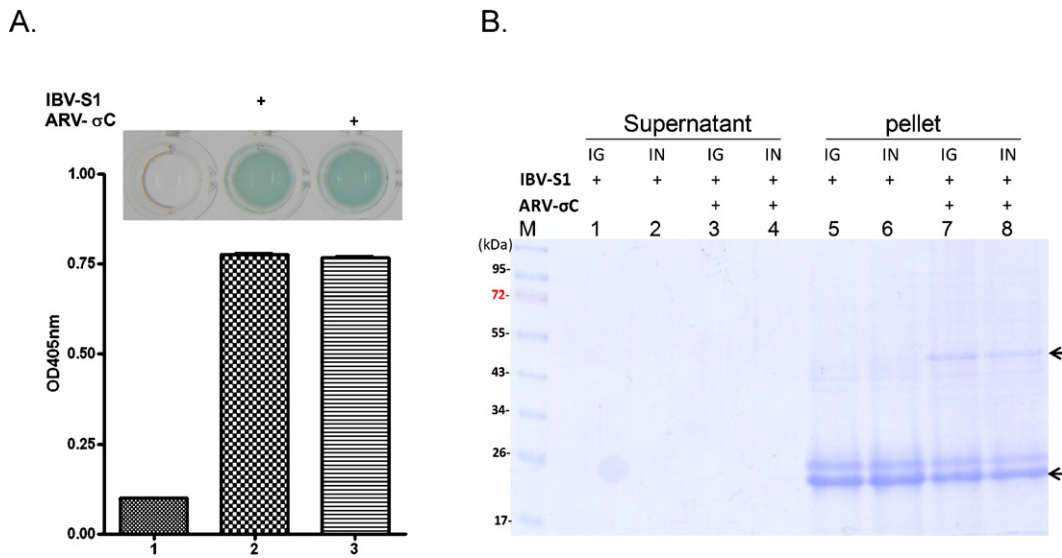

Fig. 4. Confirmation of antigen display on LAB by whole-cell ELISA and SDS-PAGE. PBS (sample 1), 20 μg of the purified IBV-S1-AcmA' (sample 2), or ARV-σC-AcmA' fusion proteins (sample 3) were incubated with 1 × 10⁹ CFU of *E. faecium*, and then display on the surface of LAB was directly detect by ELISA using anti-His tag antibody (A). Standard deviations are indicated as error bars. For immunization, various fusion proteins (as indicated on the top of gel) were incubated with LAB. After centrifugation, supernatant (unbound, free form of antigenic proteins) and pellet (LAB anchored fusion proteins) were separated and analyzed by SDS-PAGE (B). The binding efficiency was evaluated by the ratio of AcmA' fusion protein present in the bacteria pellets (anchored form) relative to that in supernatant (free form). The binding assay was done in two duplicates that were then used for intragastric (IG) and intranasal (IN) immunizations (as labeled on the top of gel). M: standard protein size marker (Fermentas).

However, significant increases in both IgG and IgA were detected in the sera and the BAL of mice immunized via the IN route (Fig. 6B and D). These results suggest that the display of recombinant proteins on LAB delivered via the IN route was successfully able to elicit both systemic and mucosal immunity. Statistically, LAB anchored with antigens (IBV-S1 with or without ARV-σC) delivered via the IN route induced a stronger mucosal immune response (indicated by

IgA titer) than that via the IG route ($p < 0.001$, analyzed by one way ANOVA). Noticeably, in combination with ARV-σC fusion protein, LAB was able to stimulate a higher antibody immune response than that LAB anchored with IBV-S-1 only or the mock LAB (Fig. 6B and D); almost all the mice immunized with ARV-σC produced higher IgA titers than mice immunized by the other two regimens (mock LAB, LAB-IBV-S-1 alone) ($p < 0.001$).

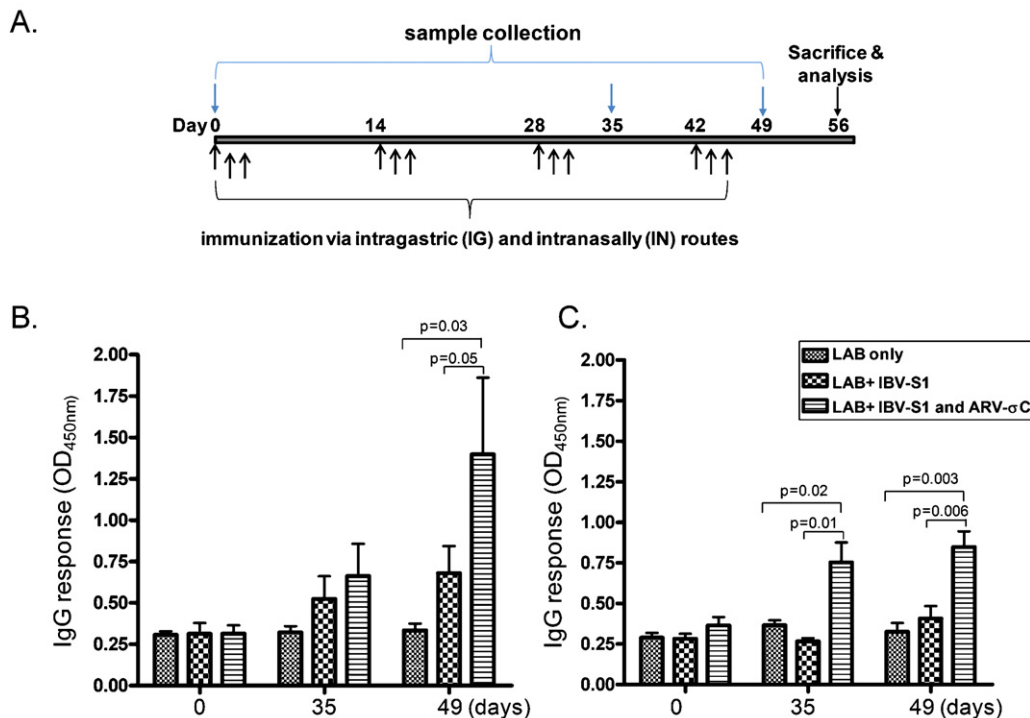

Fig. 5. Antibody (IgG) induced by mice immunized with antigenic proteins delivered by LAB. Eight-week old female BALB/c mice were immunized with LAB via the intragastric (IG) and intranasal (IN) routes. The immunization schedule used is illustrated (A). Serum samples were collected on Day 0, 35 and 49, and the IBV-S1 specific IgG responses elicited by the model antigen administered by IG (B) and IN (C) were measured by ELISA. The experiments were done three repeats and the antibody response in each group of animals was demonstrated by mean ± SEM designated by bars.

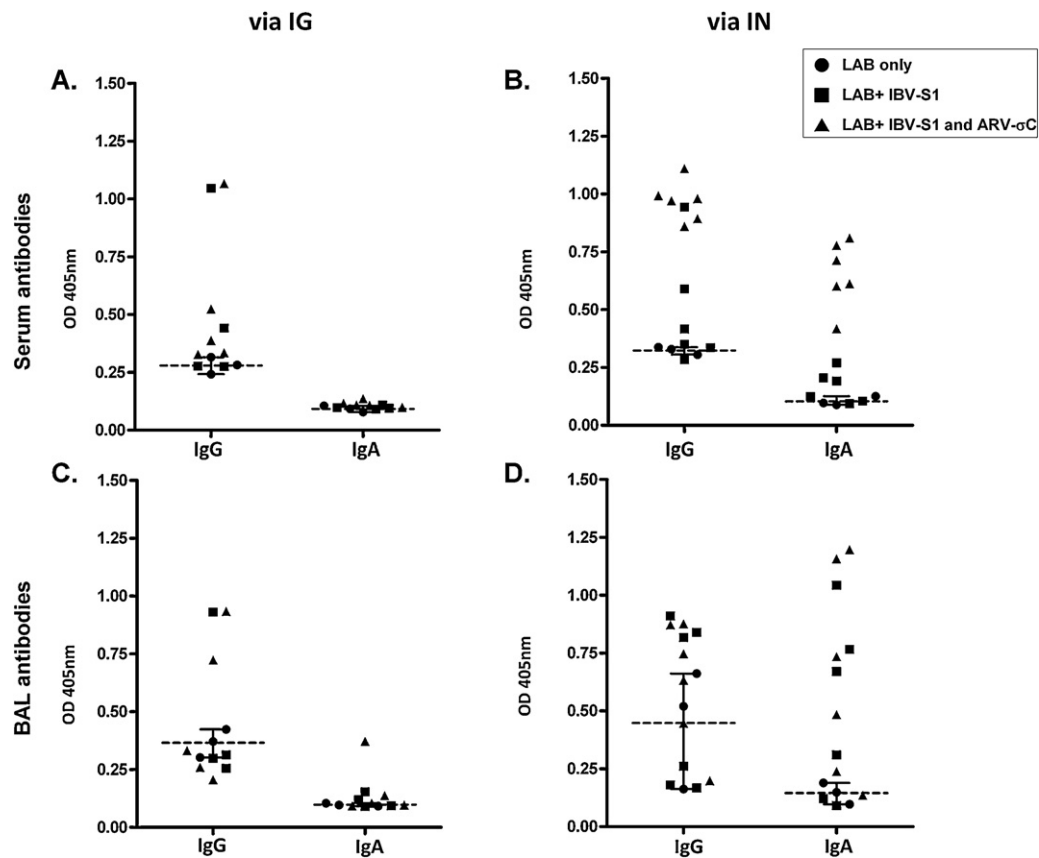

Fig. 6. Detection of systemic and mucosal antibody by ELISA. After the final booster, the mice were sacrificed (day 56). Both sera (panels A and B) and bronchoalveolar lavage samples (BAL; panels C and D) were collected from mice immunized via the IG route (panels A, C) and the IN (panels B and D) route for the detection of IBV-S1-specific IgG and IgA, indicating systemic and mucosal immune responses, respectively. The experiments were done three repeats and the mean with range value of negative control is designated by bars.

3.6. Detection of the IBV-S1 and ARV- σ C antibodies by Western blot analysis

To confirm the accuracy of ELISA results, the serum samples were further tested by Western blot analysis. As shown in Fig. 7A, two out of four (50%) sera of mice treated with LAB anchored IBV-S1 and four out of five (80%) sera treated with LAB anchored with two antigens (IBV-S1 and ARV- σ C) via the IG route recognized

recombinant IBV-S1 protein. In addition, four of six (66.7%) sera of mice treated with LAB anchored IBV-S1 and five out of six (83%) sera treated with LAB anchored with two antigens via the IN route successfully detected IBV-S1 protein (Fig. 7B). Similar to the results of the ELISA, mice immunized with LAB displaying two antigens that were immunized via the IN route induced stronger antibody reactions than via the IG route (Fig. 8A and B). It is worth noting that all the sera samples, that is 100% (6/6) via IN route,

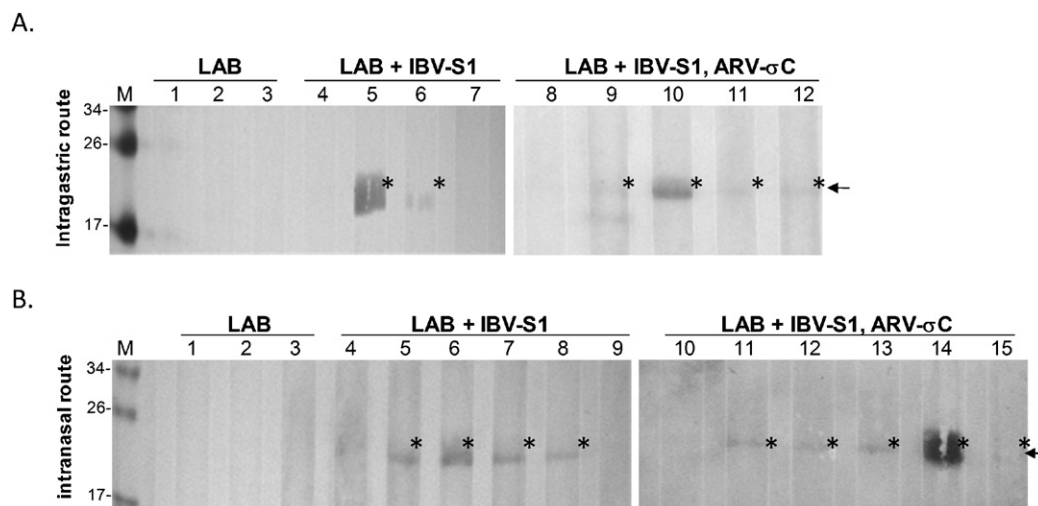

Fig. 7. Detection of IBV-S1 specific antibodies by Western blot analysis. Serum samples from mice immunized via IG (A) and IN (B) routes were collected on day 56 and IBV-S1-specific antibody response was confirmed by Western blot analysis.

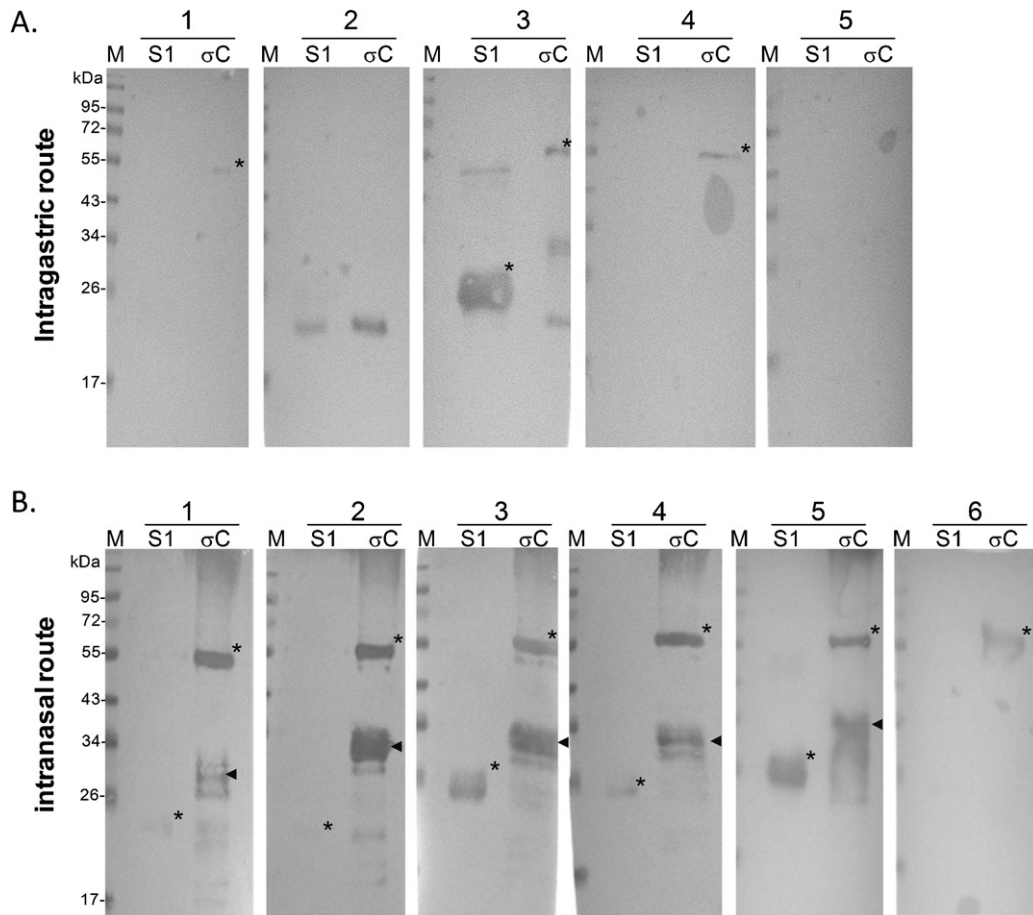

Fig. 8. Comparative analysis of IBV-S1 and ARV- σ C specific antibodies by Western blotting. Serum samples from mice immunized with LAB anchored with IBV-S1 in combination with ARV- σ C antigens via the IG (A) and IN (B) routes were collected on day 56. Antibodies specific against these two antigens were detected by Western blot analysis.

strongly reacted with ARV- σ C, compared to a smaller number that reacted strongly with IBV-S1 (Fig. 8A and B).

4. Discussion

As stimulation of the mucosal compartment is necessary for optimal protective antiviral immunity, several strategies have been designed to allow mucosal application, such as the use of a live attenuated viral vector and the use of adjuvants [36]. However, potential side effects of live viral vectors and the toxicity of bioadjuvants have been a great concern; hence, alternative vaccines or vaccine strategies are warranted. This study presented a new vaccination strategy; we show for the first time that an avian reovirus (ARV) sigma C displayed onto lactic acid bacteria (LAB) is able to enhance both systemic and mucosal immunity. To avoid the use of GMOs in any final application and to control the actual quantity of antigen in the vaccine, the heterologous proteins was expressed in *E. coli* and exogenously anchored on the LAB surface. To this end, autolysin AcmA' protein that is capable of docking on the cell wall of Gram's positive bacteria such as LAB was used as a protein anchor [37]. In our studies, one copy of the first LysM motif domain was expressed to allow fusion via the C-terminal end of all the antigenic proteins. The estimated binding capacity was shown to be at least 40 μ g AcmA' fusion protein bound to approximately 10^9 CFU of *E. faecium*, which is higher than a previously report ($\sim 10 \mu$ g of protein/ 2×10^9 cells) [28]. As all the antigenic proteins tested in this study were expressed and recovered from insoluble fraction, the

high binding efficiency indicates that step-wise dialysis was able to restore the conformation of the AcmA' protein to a great extent.

Previously Wu et al. has reported that conjugation of mammalian reovirus (MRV) recombinant sigma1 protein with a DNA vaccine enhanced antigen-specific humoral and cell-mediated immune responses when compared with naked DNA immunizations [38]. It has been suggested that sigma 1 acts as an M cell ligand that directs DNA vaccine to NALT M cells in the gut lumen and thus allows presentation to the gut mucosal inductive tissue that in turns induces mucosal immune responses [38]. ARV sigma C is a functional homologous protein of MRV sigma 1. Crystallographic studies of the partial ARV sigma C shows that the major receptor-binding domain resembles a globular head and features a triple beta-barrel and a fibrous extension of triple beta-spiral shaft domain [23]. When the crystal structures of ARV sigma C and MRV sigma 1 are superimposed, it reveals that head domains of these two proteins share a similar overall topology and the loops connecting the β -strands are also very similar [23]. In the present study, the IBV-S specific antibody titre was significantly increased in mice immunized with IBV-S1 in combination with ARV sigma C compared to LAB monovalently conjugated with IBV-S1. Based on the structural similarities, it is reasonable to suspect that ARV sigma C may possibly interact with M cells and subsequently enhances the uptake and presentation of the antigen to the effective cells in lymphoid inductive tissue. At present, the cellular receptor of ARV remains unclear and the association of sigma C with M cells has not been proved. In our current model, the enhancement of IBV-specific antibody by LAB anchored two

antigens might be not resulted from the M-cell targeting property mediated by ARV sigma C. In the gut loop assay, results of immunohistochemistry staining indicated that LAB adhered to M cells and epithelium cells, but such an interaction was not restricted to the presence of sigma C; LAB without sigma C also associated with M-cells (supplementary Fig. S1). Nevertheless, the possibility of M-cell targeting mediated by sigma C should further examined. As described previously that ARV sigma C is anchored into viral envelope as a homotrimer [39], the recombinant ARV sigma C protein used in this study was prepared from a prokaryotic system that might not generate proteins with proper conformation. Hence, to define the M-cell targeting property, eukaryotic expression systems should be a better option. Moreover, it is also possible that ARV sigma C enhances humoral immune response by stimulation of cytokine expression. Indeed, our preliminary data showed that incubation of mouse RAW264.7 cells with LAB displaying ARV sigma C significantly increased expression of IL-1 alpha, IL-1 beta, and IL-6 that were not detected in cells treated with LAB control (supplementary Fig. S2). As IL-1 cytokines acting as adjuvants in the upregulation of humoral and cellular responses to antigen has been shown in several animal models such as in sheep [40] and chicken [41]. In addition, IL-6 has been shown to contribute to stimulation of IgA expression [42,43]. It is likely that enhancement of humeral response by ARV sigma C in the mouse model is through stimulation of IL-1 cytokines. Nevertheless, the mechanism of immunostimulating can be complicated that requires further investigation.

In current study, two model antigens from the avian-origin viruses were used for evaluation of whether the new LAB strain can be used as a general vaccine carrier. Since neither the distribution nor the function of M cells in chicken have been reported, a murine model was used as an alternative. Nevertheless, to broaden the use of these LAB strains, more animal species should be tested.

The impact of vaccination route on stimulation of mucosal immunity by antigen-displayed LAB delivery systems has been demonstrated in the present study and others. Although LAB strains are natural inhabitants of the intestine, which is consistent with our findings, several reports have documented that immunization by a LAB delivery systems via the intranasal route is an more effective and elicits high levels of serum IgG and mucosal IgA against the target antigens when compared with the IG route [9,11]. It is worth noting that with the IG route the antigen is displayed on the surface of the LAB where it is less protected when delivered without bicarbonate to neutralize the gastric acid. In such circumstances, instability of the antigen might affect the induction of the immune response. Very recently, in addition to NALT, Kim et al. identified another type of M cells with an antigen uptake function, namely respiratory M cells, which are present as a single-layer epithelium of turbinates in the murine nasal cavity [44]. As respiratory M cells are more abundant than NALT M cells and the uptake of insoluble antigen (*Salmonella* spp.) was found to be much more efficient than with NALT. This suggests that the respiratory M cells play a critical role in the gateway/barrier of the upper airway. Furthermore, it has been shown that among the various vaccination routes, nasal immunization is able to induce specific IgA as well as systemic IgG2a and IgG2b responses mediated by antigen-specific CD4⁺ Th2- and Th1-type cells [45]. These findings support the idea that the intranasal immunization is a promising avenue for the uptake of bacteria-delivered vaccines and induction of both systemic and mucosal immunity.

In conclusion, our results shed light on the potential use of *E. faecium* as a delivery vehicle for intranasal immunization, and suggest that ARV sigma C can be considered to be a safe and effective immune-enhancing molecule (or adjuvant) for mucosal immunization when included in avian vaccine formulations.

Acknowledgements

This study was partly supported by the Bureau of Animal and Plant Health Inspection and Quarantine, the Council of Agriculture, grant number: 97-1.1.5-B1(6) and 98-9.2.4-B8(9).

Appendix A. Supplementary data

Supplementary data associated with this article can be found, in the online version, at <http://dx.doi.org/10.1016/j.vaccine.2012.04.043>.

References

- [1] Neutra MR, Kozlowski PA. Mucosal vaccines: the promise and the challenge. *Nature Reviews Immunology* 2006;6(February 2):148–58.
- [2] Mestecky J, Blumberg R, Kiyono H, McGhee JR. In: Paul WE, editor. *Fundamental immunology*. 5th ed. San Diego: Academic; 2003. p. 965–1020.
- [3] Iwasaki A. Mucosal dendritic cells. *Annual Review of Immunology* 2007;25:381–418.
- [4] Medina E, Guzman CA. Use of live bacterial vaccine vectors for antigen delivery: potential and limitations. *Vaccine* 2001;19(February (13–14)):1573–80.
- [5] Yuki Y, Kiyono H. New generation of mucosal adjuvants for the induction of protective immunity. *Reviews in Medical Virology* 2003;13(September–October (5)):293–310.
- [6] Holmgren J, Czerkinsky C. Mucosal immunity and vaccines. *Nature Medicine* 2005;11(April (4 Suppl)):S45–53.
- [7] Bermudez-Humaran LG, Cortes-Perez NG, Le Loir Y, Alcocer-Gonzalez JM, Tamez-Guerra RS, de Oca-Luna RM, et al. An inducible surface presentation system improves cellular immunity against human papillomavirus type 16 E7 antigen in mice after nasal administration with recombinant lactococci. *Journal of Medical Microbiology* 2004;53(May (Pt 5)):427–33.
- [8] Bermudez-Humaran LG, Cortes-Perez NG, Lefevre F, Guimaraes V, Rabot S, Alcocer-Gonzalez JM, et al. A novel mucosal vaccine based on live Lactococci expressing E7 antigen and IL-12 induces systemic and mucosal immune responses and protects mice against human papillomavirus type 16-induced tumors. *Journal of Immunology* 2005;175(December (11)):7297–302.
- [9] Lee JS, Poo H, Han DP, Hong SP, Kim K, Cho MW, et al. Mucosal immunization with surface-displayed severe acute respiratory syndrome coronavirus spike protein on *Lactobacillus casei* induces neutralizing antibodies in mice. *Journal of Virology* 2006;80(April (8)):4079–87.
- [10] Cortes-Perez NG, Azevedo V, Alcocer-Gonzalez JM, Rodriguez-Padilla C, Tamez-Guerra RS, Corthier G, et al. Cell-surface display of E7 antigen from human papillomavirus type-16 in *Lactococcus lactis* and in *Lactobacillus plantarum* using a new cell-wall anchor from lactobacilli. *Journal of Drug Targeting* 2005;13(February (2)):89–98.
- [11] Cortes-Perez NG, Lefevre F, Corthier G, Adel-Patient K, Langella P, Bermudez-Humaran LG. Influence of the route of immunization and the nature of the bacterial vector on immunogenicity of mucosal vaccines based on lactic acid bacteria. *Vaccine* 2007;25(September (36)):6581–8.
- [12] Mohamadzadeh M, Olson S, Kalina WV, Ruthel G, Demmin GL, Warfield KL, et al. Lactobacilli activate human dendritic cells that skew T cells toward T helper 1 polarization. *Proceedings of the National Academy of Sciences of the United States of America* 2005;102(February (8)):2880–5.
- [13] Vissers YM, Snel J, Zuurendonk PF, Smit BA, Wichers HJ, Savelkoul HF. Differential effects of *Lactobacillus acidophilus* and *Lactobacillus plantarum* strains on cytokine induction in human peripheral blood mononuclear cells. *FEMS Immunology & Medical Microbiology* 2010;59(June (1)):60–70.
- [14] Surono IS, Koestomo FP, Novitasari N, Zakaria FR, Yulianasari Koesnandar. Novel probiotic *Enterococcus faecium* IS-27526 supplementation increased total salivary sIgA level and bodyweight of pre-school children: A pilot study. *Anaerobe* 2011;17(6):496–500.
- [15] Ditu, Chifiriuc L-M, Bezirtzoglou MC, Voltzi EC, Bleotu C, Pelinescu D, et al. Modulation of virulence and antibiotic susceptibility of enteropathogenic *Escherichia coli* strains by *Enterococcus faecium* probiotic strain culture fractions. *Anaerobe* 2011;17(6):448–51.
- [16] Bybee SN, Scorza AV, Lappin MR. Effect of the probiotic *enterococcus faecium* SF68 on presence of diarrhea in cats and dogs housed in an animal shelter. *Journal of Veterinary Internal Medicine* 2011;25(4):856–60.
- [17] Ogier J-C, Serror P. Safety assessment of dairy microorganisms: The *Enterococcus* genus. *International Journal of Food Microbiology* 2008;126(3):291–301.
- [18] Lai MM, Cavanagh D. The molecular biology of coronaviruses. *Advances in Virus Research* 1997;48:1–100.
- [19] Masters PS. The molecular biology of coronaviruses. *Advances in Virus Research* 2006;66:193–292.
- [20] Gallagher TM, Buchmeier MJ. Coronavirus spike proteins in viral entry and pathogenesis. *Virology* 2001;279(January (2)):371–4.
- [21] Meanger J, Wickramasinghe R, Enriquez CE, Wilcox GE. Immune response to avian reovirus in chickens and protection against experimental infection. *Australian Veterinary Journal* 1997;75(June (6)):428–32.

- [22] Wickramasinghe R, Meanger J, Enriquez CE, Wilcox GE. Avian reovirus proteins associated with neutralization of virus infectivity. *Virology* 1993;194(June (2)):688–96.
- [23] Guardado Calvo P, Fox GC, Hermo Parrado XL, Llamas-Saiz AL, Costas C, Martinez-Costas J, et al. Structure of the carboxy-terminal receptor-binding domain of avian reovirus fibre sigmaC. *Journal of Molecular Biology* 2005;354(November (1)):137–49.
- [24] Helander A, Silvey KJ, Mantis NJ, Hutchings AB, Chandran K, Lucas WT, et al. The viral sigma1 protein and glycoconjugates containing alpha2–3-linked sialic acid are involved in type 1 reovirus adherence to M cell apical surfaces. *Journal of Virology* 2003;77(July (14)):7964–77.
- [25] Mishra N, Tiwari S, Vaidya B, Agrawal GP, Vyas SP. Lectin anchored PLGA nanoparticles for oral mucosal immunization against hepatitis B. *Journal of Drug Targeting* 2011;19(January (1)):67–78.
- [26] Gupta PN, Vyas SP. Investigation of lectinized liposomes as M-cell targeted carrier-adjuvant for mucosal immunization. *Colloids and Surfaces B: Biointerfaces* 2011;82(January (1)):118–25.
- [27] Desvaux M, Dumas E, Chafsey I, Hebraud M. Protein cell surface display in Gram-positive bacteria: from single protein to macromolecular protein structure. *FEMS Microbiology Letters* 2006;256(March (1)):1–15.
- [28] Raha AR, Varma NR, Yusoff K, Ross E, Foo HL. Cell surface display system for *Lactococcus lactis*: a novel development for oral vaccine. *Applied Microbiology and Biotechnology* 2005;68(July (1)):75–81.
- [29] Ignjatovic J, Sapats S. Identification of previously unknown antigenic epitopes on the S and N proteins of avian infectious bronchitis virus. *Archives of Virology* 2005;150(September (9)):1813–31.
- [30] Bergeron Y, Ouellet N, Deslauriers AM, Simard M, Olivier M, Bergeron MG. Cytokine kinetics and other host factors in response to pneumococcal pulmonary infection in mice. *Infection and Immunity* 1998;66(March (3)):912–22.
- [31] Havennar R, Husis JHJ. In: Wood BJB, editor. *The lactic acid bacteria*. London: Elsevier Press; 1992.
- [32] Alander M, Korpela R, Saxelin M, Vilpponen-Salmela T, Mattila-Sandholm T, von Wright A. Recovery of *Lactobacillus rhamnosus* GG from human colonic biopsies. *Letters in Applied Microbiology* 1997;24(May (5)):361–4.
- [33] Lin WH, Hwang CF, Chen LW, Tsen HY. Viable counts, characteristic evaluation for commercial lactic acid bacteria products. *Food Microbiology* 2006;23(February (1)):74–81.
- [34] Vesterlund S, Karp M, Salminen S, Ouwehand AC. *Staphylococcus aureus* adheres to human intestinal mucus but can be displaced by certain lactic acid bacteria. *Microbiology* 2006;152(June (6)):1819–26.
- [35] Collado MC, Meriluoto J, Salminen S. Role of commercial probiotic strains against human pathogen adhesion to intestinal mucus. *Letters in Applied Microbiology* 2007;45(4):454–60.
- [36] Lawson LB, Norton EB, Clements JD. Defending the mucosa: adjuvant and carrier formulations for mucosal immunity. *Current Opinion in Immunology* 2011;23(June (3)):414–20.
- [37] Buist G, Karsens H, Nauta A, van Sinderen D, Venema G, Kok J. Autolysis of *Lactococcus lactis* caused by induced overproduction of its major autolysin, AcmA. *Applied and Environmental Microbiology* 1997;63(July (7)):2722–8.
- [38] Wu Y, Wang X, Csencsits KL, Haddad A, Walters N, Pascual DW. M cell-targeted DNA vaccination. *Proceedings of the National Academy of Sciences of the United States of America* 2001;98(July (16)):9318–23.
- [39] Guardado-Calvo P, Fox GC, Llamas-Saiz AL, van Raaij MJ. Crystallographic structure of the α -helical triple coiled-coil domain of avian reovirus S1133 fibre. *Journal of General Virology* 2009;90(March (3)):672–7.
- [40] Nash AD, Lofthouse SA, Barcham GJ, Jacobs HJ, Ashman K, Meeusen ENT, et al. Recombinant cytokines as immunological adjuvants. *Immunology and Cell Biology* 1993;71(5):367–79.
- [41] Schijns VE, Weining KC, Nuijten P, Rijke EO, Staeheli P. Immunoadjuvant activities of *E. coli*- and plasmid-expressed recombinant chicken IFN-alpha/beta, IFN-gamma and IL-1beta in 1-day- and 3-week-old chickens. *Vaccine* 2000;18(April (20)):2147–54.
- [42] Ramsay A, Husband A, Ramshaw I, Bao S, Matthaek K, Koehler G, et al. The role of interleukin-6 in mucosal IgA antibody responses in vivo. *Science* 1994;264(April (5158)):561–3.
- [43] Yan D, Zhou HR, Brooks KH, Pestka JJ. Potential role for IL-5 and IL-6 in enhanced IgA secretion by Peyer's patch cells isolated from mice acutely exposed to vomitoxin. *Toxicology* 1997;122(September (1–2)):145–58.
- [44] Kim DY, Sato A, Fukuyama S, Sagara H, Nagatake T, Kong IG, et al. The airway antigen sampling system: respiratory M cells as an alternative gateway for inhaled antigens. *Journal of Immunology* 2011;186(April (7)):4253–62.
- [45] Kurono Y, Yamamoto M, Fujihashi K, Kodama S, Suzuki M, Mogi G, et al. Nasal immunization induces *Haemophilus influenzae*-specific Th1 and Th2 responses with mucosal IgA and systemic IgG antibodies for protective immunity. *Journal of Infectious Diseases* 1999;180(July (1)):122–32.