

Original

## Ergonomic considerations for designing truck drivers' seats: The case of Bangladesh

Pobitra Halder<sup>1,2</sup>, Tamanna Mahmud<sup>2</sup>, Eity Sarker<sup>3</sup>, ChitraLekha Karmaker<sup>2</sup>,  
Sazal Kundu<sup>1</sup>, Savankumar Patel<sup>1</sup>, Adi Setiawan<sup>4</sup> and Kalpit Shah<sup>1</sup>

<sup>1</sup>Chemical and Environmental Engineering, School of Engineering, RMIT University, Australia, <sup>2</sup>Department of Industrial and Production Engineering, Jessore University of Science and Technology, Bangladesh, <sup>3</sup>Hajee Mohammad Danesh Science & Technology University, Bangladesh and <sup>4</sup>Department of Mechanical Engineering, Faculty of Engineering, Universitas Malikussaleh, Indonesia

**Abstract: Objectives:** The purpose of this work was to investigate the fitness of the existing truck seats for Bangladeshi truck drivers and suggest a guideline for drivers' seats based on their anthropometry. **Methodology:** In this study, eight anthropometric measurements of 120 Bangladeshi truck drivers and seven seat dimensions of ninety trucks of three brands namely, TATA, ASHOK LEYLAND, and ISUZU were considered for investigating the considerable mismatch between seat dimensions and drivers' anthropometry. The data were analyzed using two-sample t-tests to identify the relationship between existing seat dimensions and drivers' anthropometry. **Results:** The results showed a mismatch in seat dimensions and anthropometric measurements for nearly all truck brands and the existing seat dimensions were found to be inappropriate for Bangladeshi drivers. For all the truck brands, the percentage mismatch of seat height, seat depth, seat width, backrest height, and steering wheel clearance varied between 71% and 98%, 23% and 79%, 33% and 84%, 28% and 65%, and 53% and 100% respectively. Subsequently, an attempt was made to provide ergonomically correct seat dimensions for Bangladeshi truck drivers. Further, generalized equations to design the appropriate seat dimensions were developed using the least square regression technique. The recommended seat height, depth and width, backrest height, and steering wheel clearance were found to be appropriate for 82%, 79%, 76%, 98%, and 100% of drivers respectively. **Conclusion:** The analysis and re-

sults of this study can be useful in developing guidelines for design and manufacture of truck driver seats in Bangladesh.

(J Occup Health 2018; 60: 64-73)

doi: 10.1539/joh.16-0163-OA

**Key words:** Anthropometry, Bangladesh, Mismatch, Seat dimensions, Truck driver

### 1. Introduction

Ergonomics is the relationship between people and their work environment. The interrelationship between user's anthropometry and furniture dimensions has a significant effect on the work efficiency as well as health of the workers. Improper furniture design causes discomfort, pain and disorders in the neck, shoulder, back, arm, hand, and wrist that can lead to musculoskeletal diseases<sup>1</sup>. The concept of ergonomic furniture design has been applied for the first time in 1940<sup>2</sup>. Now, it is broadly used in industrial and service sectors for designing workstation's furniture and equipment<sup>3,5</sup>.

Starting in 1990, researchers noticed that the vehicle's seat design and driver's sitting posture significantly affect the driver's comfort<sup>6</sup>. Recently, various seat evaluation techniques were developed considering drivers' body pressure distribution and anthropometric data<sup>7,9</sup>. Anthropometric dimensions have a direct effect on sitting (Kovačević et al.<sup>10</sup>). Ciloglu et al.<sup>11</sup> investigated the effects of body vibration on the dynamic seat comfort of aircraft seats during takeoff and landing. Filtness et al.<sup>12</sup> studied three different vehicle seats and two different appointments carriage options used by an Australian police officer. The study revealed that the potential mismatch

Received June 30, 2016; Accepted October 17, 2017

Published online in J-STAGE November 18, 2017

Correspondence to: P. Halder, Chemical and Environmental Engineering, School of Engineering, RMIT University, Melbourne, Victoria 3001, Australia (e-mail: s3634814@student.rmit.edu.au)

between seats dimensions and officers' anthropometry caused their discomfort. Mehta et al.<sup>13)</sup> recommended optimal seat measurements for Indian tractor operators after reviewing the existing seat dimensions and their anthropometry. Ajayeoba and Adekoya<sup>14)</sup> studied anthropometric data of 939 passengers (612 male and 327 female) to evaluate the anthropometric suitability of seats of 92 locally made commuter buses in Nigeria and proposed new seat dimensions. Márquez and Garcia<sup>15)</sup> outlined suggestions based on ergonomics to improve the design of a passenger vehicle in Venezuela. Mazloumi and Mohammadreze<sup>16)</sup> investigated the effect of the interior design on the drivers' sitting posture in Iranian shoka vehicles and proposed some sitting angles for comfortable sitting. Ismaila et al.<sup>17)</sup> examined the potential mismatch between the anthropometric dimensions of 200 passengers and seat measurements of 30 Toyota Hiace buses in Nigeria. Jahns et al.<sup>18)</sup> reported a method to evaluate general vehicle driving postures. Tan et al.<sup>19)</sup> proposed a measurement technique and developed an intelligent system for the design of truck seats that reduces discomfort for the drivers. Onawumi and Lucas<sup>20)</sup> investigated the ergonomic suitability of the seat dimensions of taxicabs in Nigeria based on the drivers' anthropometric data. Zhou et al.<sup>21)</sup> analyzed anthropometric measurements of 1243 vehicle drivers of aged between 17 and 34 years for developing correlation and fitting formulas for body height, sitting height, and other parameters.

The ergonomic design of truck drivers' seats is an important issue for the design engineer as truck drivers usually spend at least 2400 h on road in a year. Studies on this issue have been published for Nigeria, Australia, India, Iran, and South Africa. However, to the best of our knowledge, there are no studies of truck drivers' anthropometry and seat dimensions for Bangladesh. In the current work, anthropometric measurements of Bangladeshi truck drivers in the Khulna zone and seat dimensions of three truck brands (TATA, ASHOK LEYLAND, and ISUZU) were studied in detail. The study investigated the possible mismatch between seat dimensions and corresponding anthropometric characteristics of truck drivers and various physical problems associated with the mismatch. The data were analyzed using various test statistics for recommending optimal seat dimensions.

## 2. Materials and Methods

### 2.1. Sample and measuring technique

This study is based on anthropometric measurements of 120 normal healthy truck drivers aged between 30 and 60 years with a mean and standard deviation of 41.00 years and 5.99 years respectively. Data were collected from the central storage depot in Khalishpur, Khulna, Bangladesh. A written authorization was obtained from the chairman of the storage depot. The sample size was determined ac-

ording to Hicks<sup>22)</sup> method with a 90% confidence level,  $z = 1.64$ , and 6% sampling error. This study was conducted from December 2013 to November 2014. During this period, physical problems such as foot cramp, neck pain, back pain, muscle weakness at the hip region of the truck drivers were compared to that of people not related to this occupation (control group). Data were collected through a set of structured questionnaires which were completed by truck drivers and the control group using a bottom up survey method. Written questionnaires were provided to the participants and they were asked to describe accurately any physical problems.

In this investigation, seat dimensions of 30 trucks of each brand (TATA, ASHOK LEYLAND, and ISUZU) were considered. All measurements were taken according to the method described by Pheasant and Haslegrave<sup>23)</sup> and Abeysekera<sup>24)</sup>. Mean, standard deviation (St. Dev.), minimum value, maximum value, percentiles (5th, 50th, and 95th) were estimated from the anthropometric data of drivers and seat dimensions using R software package (version 3.3.1). Anthropometric data were compared with seat dimensions by using independent samples t-test (two tails) at a 95% confidence level.

To measure the difference between the drivers' anthropometric measurements and seat dimensions, linear regression analysis was performed using R (version 3.3.1). Here seat dimensions were set as predicted/dependent variable and drivers' anthropometry was set as an independent variable. According to Chakraborty et al.<sup>25)</sup> only drivers' stature was considered as independent variable in linear regression.

### 2.2. Anthropometric measurements

In this study, truck drivers' anthropometries were considered as the fundamental basis for design of seat dimensions. Here evaluated stature (S), popliteal height (PH), buttock popliteal length (BPL), hip breadth (HB), sitting shoulder height (SSH), arm length (AL), abdominal depth (AD) and thigh clearance (TC) as shown in Fig. 1 were considered most relevant to the seat measurements. These anthropometric data were further compared with the body dimensions from the list described in ISO 7250<sup>26)</sup>. The anthropometric dimensions were measured in standard sitting and standing positions without shoes and wearing a light normal vest with no pockets as described by Castellucci et al.<sup>27)</sup>. During the measurement, drivers were seated in an erect position on adjustable seat with a horizontal surface. The lower and upper legs were pointed at right angles.

*Stature (S)*: The vertical distance measured from the footrest to the highest point of the head with standing completely upright, keeping feet together and looking straight forward.

*Popliteal height (PH)*: The distance measured vertically from the floor (foot resting surface) to the popliteal

crease just behind the knee at sitting position.

**Buttock popliteal length (BPL):** The horizontal distance measured from the posterior surface of the buttock to the posterior surface of the knee where the back of the lower legs and the underside of the thigh form right angle.

**Hip breadth (HB):** The maximum horizontal distance measured across the hips in the sitting position.

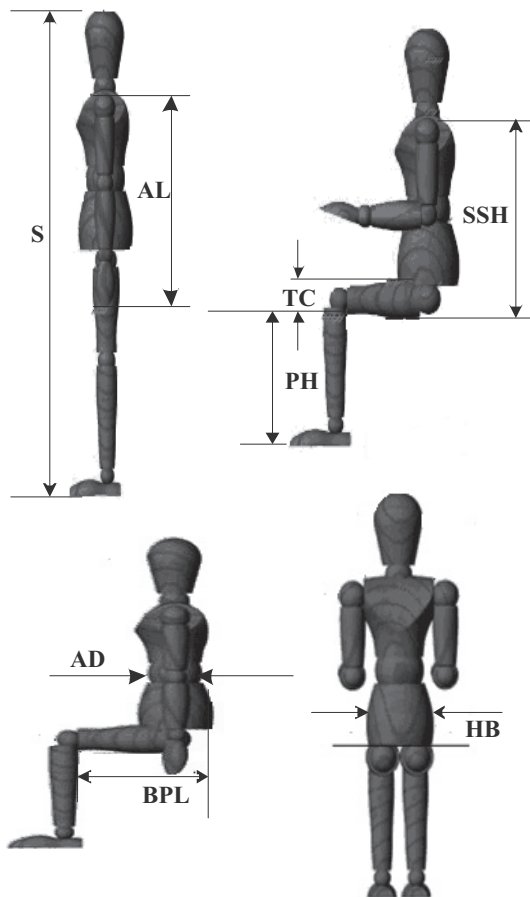

**Fig. 1.** Anthropometric measurements of drivers  
PH: Popliteal height, TC: Thigh clearance, BPL: Buttock-popliteal length, HB: Hip breadth, SSH: Sitting shoulder height, AD: Abdominal depth, AL: Arm length, S: Stature.

**Sitting shoulder height (SSH):** The vertical distance measured from the horizontal sitting surface to the top of the shoulder at the acromion with the arms hanging without restraint and the shoulders relaxed.

**Thigh clearance (TC):** The vertical distance measured from the horizontal sitting surface to the highest point on the thigh with an uncompressed soft tissue.

**Abdominal depth (AD):** The maximum distance measured horizontally in a standard sitting position from the vertical reference plane to the front of the abdomen.

**Arm length (AL):** The distance measured from the neck to the tip of the outstretched middle finger.

### 2.3. Seat measurements

Normally, truck drivers' seats are not made with standard dimensions that fit the anthropometric data. Therefore, the following dimensions of existing truck drivers' seats (Fig. 2) were measured.

**Seat height (SH):** The vertical distance measured from the floor to the midpoint of the front edge of the seat.

**Seat depth (SD):** The horizontal distance measured from the front edge of the sitting surface of the seat to the back edge.

**Seat width (SW):** The distance measured horizontally between the lateral edges of the seat.

**Backrest height (BH):** The vertical distance measured from the upper edge of the backrest to the horizontal sitting surface.

**Steering wheel clearance (SWC):** The distance measured vertically from the top front edge of the seat to the lowest point on the steering wheel.

**Back support to steering wheel (BSSW):** The minimum distance measured horizontally from the back support to the steering wheel.

**Back support to front of steering wheel (BSFSW):** The maximum horizontal distance measured from the back support to the front of the steering wheel.

### 2.4. Seat measurements and body dimensions mismatch

A potential match/mismatch analysis (which can identify incompatibility between seat dimensions and body dimensions of truck drivers) between the anthropometric

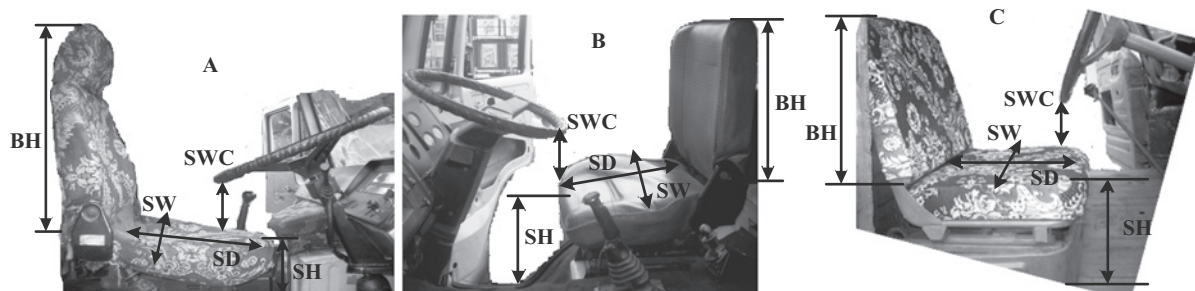

**Fig. 2.** Seat measurements of truck (A) TATA, (B) ASHOK LEYLAND, and (C) ISUZU  
SH= Seat height, BH= Backrest height, SW= Seat width, SD= Seat depth, SWC=Steering wheel clearance

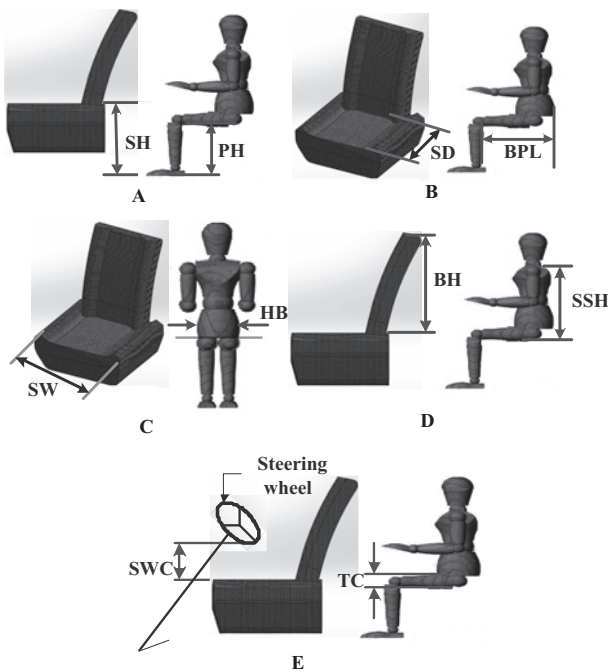

**Fig. 3.** The relationship between (A) PH and SH (B) BPL and SD (C) HB and SW (D) SSH and BH (E) TC and SWC

data and relevant existing seat dimensions is required for recommending optimal seat dimensions. The most commonly recommended relationships for match or mismatch as derived from the literature are described below and shown in Fig. 3.

**2.4.1. Popliteal height (PH) and seat height (SH) match/mismatch**

It is necessary to adjust SH according to PH to ensure comfort during driving. Molenbroek et al.<sup>28)</sup> and Parcels et al.<sup>29)</sup> recommended that PH should be higher than SH and knee should be flexed enough to allow the lower legs to form an angle of 5°-30° with the vertical. The misfit of SH with PH is expected to have harmful effects on the human body. An SH that is too high increases pressure on the popliteal fold while an SH that is too low rises load on the ischia tuberosity. These conditions are responsible for a decrease in blood circulation and an increase in nerve pressure. Parcels et al.<sup>29)</sup> and Gutiérrez and Morgado<sup>30)</sup> recommended that the SH should be less than 4 cm or 88% of the PH to avoid pressure on the buttocks. Moreover, Parcels et al.<sup>29)</sup> reported that an SH between 88% and 95% of PH is sufficient to avoid the above mentioned medical conditions. Evans et al.<sup>31)</sup>, Helander<sup>32)</sup> and Pheasant<sup>33)</sup> suggested using fifth percentile of the PH for estimating the optimum SH value. Therefore, considering 3 cm correction factor for shoe sole height, a match criterion between PH and SH was defined according to equation (1).

$$(PH + 3) \cos 30^\circ \leq SH \leq (PH + 3) \cos 5^\circ \quad (1)$$

**2.4.2. Buttock popliteal length (BPL) and seat depth (SD) match/mismatch**

It is evident from the studies conducted by Evans et al.<sup>31)</sup>, Gutiérrez and Morgado<sup>30)</sup>, Milanese and Grimmer<sup>34)</sup>, and Osborne<sup>35)</sup> and Pheasant<sup>33)</sup> that an SD within the fifth percentile of the BPL distribution is suitable to support the lumbar spine with the backrest avoiding popliteal compression. Oyewole et al.<sup>36)</sup> suggested larger value of the BPL than SD so that the seat dimensions match for large populations. In addition, Poulakakis and Marmaras<sup>37)</sup> reported that the BPL should be 5 cm larger than SD for a proper fit of seats. Parcels et al.<sup>29)</sup> matched SD and BPL using equation (2).

$$0.80 \text{ BPL} \leq SD \leq 0.95 \text{ BPL} \quad (2)$$

**2.4.3. Hip breadth (HB) and seat width (SW) mismatch**

Evans et al.<sup>31)</sup>, Gutiérrez and Morgado<sup>30)</sup>, Milanese and Grimmer<sup>34)</sup>, and Osborne<sup>35)</sup> and Pheasant<sup>33)</sup> suggested that the SW should be selected based on the largest HB, as the smallest HB can be adjusted properly on the largest SW. Oyewole et al.<sup>36)</sup> also suggested that larger SW is more suitable. In addition, Evans et al.<sup>31)</sup>, Gutiérrez and Morgado<sup>30)</sup>, Milanese and Grimmer<sup>34)</sup>, and Osborne<sup>35)</sup> and Pheasant<sup>33)</sup> suggested that the optimal value for the SW is around the 95th percentile of the HB distribution. Gouvali and Boudolos<sup>38)</sup> recommended a match criterion of SW between a minimum of 110% and maximum of 130% of HB as illustrated in equation (3).

$$1.10 \text{ HB} \leq SW \leq 1.30 \text{ HB} \quad (3)$$

**2.4.4. Sitting shoulder height (SSH) and backrest height (BH) match/mismatch**

Evans et al.<sup>31)</sup> and Osborne<sup>35)</sup> showed that the BH should be smaller than SSH. Therefore, the fifth percentile of the SSH distribution is an appropriate choice for BH so that the SSH can accommodate large populations to facilitate arm movement. Agha<sup>39)</sup> and Gouvali and Boudolos<sup>38)</sup> suggested that between 60% and 80% of SSH is a good choice for BH as illustrated by equation (4).

$$0.60 \text{ SSH} \leq BH \leq 0.80 \text{ SSH} \quad (4)$$

**2.4.5. Thigh clearance (TC) and steering wheel clearance (SWC) match/mismatch**

García-Acosta and Lange-Morales<sup>40)</sup> and Molenbroek et al.<sup>28)</sup> found that the lower values of TC compared to desk clearance is suitable for chair and table design. Parcels et al.<sup>29)</sup> and Poulakakis and Marmaras<sup>37)</sup> recommended desk height to be 20 to 50 mm larger than knee height for the optimum design. The TC should ideally be lower than SWC to allow the driver to move comfortably their thigh and lower leg. The match criterion between TC and SWC was established in equation (5).

$$(TC + 2) < SWC \quad (5)$$

**3. Results, Discussion, and Recommendation**

**3.1. Results and discussion**

The analysis of the study found that the Bangladeshi

**Table 1.** Relevant anthropometric data (cm) of Bangladeshi truck drivers (n=120)

Anthropometric measurements	Mean	St. Dev.	Max.	Min.	Percentile (%)		
					5th	50th	95th
Sitting shoulder height	59.0	3.6	67.0	48.0	52.6	59.3	64.0
Thigh clearance	14.6	1.8	19.0	11.0	11.5	15.0	17.5
Popliteal height	43.4	2.5	49.0	37.0	39.1	43.0	47.1
Buttock popliteal length	43.8	3.0	50.2	36.0	39.0	44.0	48.5
Hip breadth	37.7	3.0	45.0	30.0	33.0	37.6	42.5
Abdominal depth	26.4	2.4	27.9	22.9	23.4	27.3	27.9
Arm length	76.8	1.5	78.0	75.5	75.5	76.8	78.0
Stature	164.5	7.0	179.0	151.0	155.0	164.1	177.0

truck drivers face various physical problems due to the improper seat design. Back pain was the most common problem among truck drivers (>90%) and was relatively low in the control group (~40%). About 83% of truck drivers suffered from foot cramps, while only 34% of the control group had this problem. Approximately 77% of the drivers suffered from neck pain whereas, only 23% of the control people experienced from this problem. The seat dimensions of trucks are also inappropriate for Indian drivers. As a result, drivers suffer from various medical conditions like back pain, foot cramp, neck problem etc. during long driving<sup>41</sup>. Therefore, ergonomics should be considered for appropriate seats design<sup>41,42</sup>.

Measurement results of eight anthropometric dimensions including the minimum, maximum, mean, standard deviation, and percentiles (cm) of Bangladeshi truck drivers of different ages are presented in Table 1. The mean of S, SSH, PH, TC, BPL, HP, AD, and AL were 164.5±7.0 cm, 59.0±3.6 cm, 43.4±2.5 cm, 14.6±1.8 cm, 43.8±3.0 cm, 37.7±3.0 cm, 26.4±2.4 cm and 76.8±1.5 cm respectively.

The statistics of the seven existing seat dimensions (cm) of trucks from TATA, ASHOK LEYLAND, and ISUZU are shown in Table 2. The mean values of SH for TATA, ASHOK LEYLAND, and ISUZU were 47.3±0.2 cm, 51.3±0.2 cm, and 36.3±0.2 cm respectively. The mean values of SD were 38.2±0.2 cm, 44.2±0.2 cm, and 41.4±0.3 cm respectively. From Table 2, it is obvious that ISUZU had the largest SW (52.4±0.3 cm), while TATA had the largest BH (48.3±0.2 cm) among the three brands. The BSSW for ASHOK LEYLAND was higher (37.4±0.2 cm) compared to TATA (36.8±0.1 cm) and ISUZU (35.5±0.1 cm). In addition, ASHOK LEYLAND had larger BSFSW (83.7±0.1 cm) than the other two brands.

Two-sample t-tests were performed to investigate the differences between anthropometric data and seat dimensions for TATA, ASHOK LEYLAND and ISUZU as presented in Table 3. The results indicated that the pair of BPL and SD for ASHOK LEYLAND had the lowest calculated t-value (1.4). In this case the calculated t-value

was lower than the critical t-value (2.0). On the other hand, the calculated t-values of all other pairs for all of the truck brands varied from 3.0 to 53.7 which were significantly higher than the critical t-value (2.0). Besides, the p-value (0.163606) for the pair of BPL and SD for ASHOK LEYLAND was not significant at p<0.05 while for all other cases the p-value was significant at p<0.05.

Our results clearly indicate that there are significant differences between the distributions of PH and SH, HB and SW, BPL and SD, SSH and BH, and TC and SWC. The percentages of drivers whose anthropometric measurements matched well or did not match at all (i.e., high mismatch or low mismatch) with the mean values of existing seat dimensions of each truck brand are shown in Table 4. Table 4 clearly shows that SH was too high (high mismatch) for 71% and 98% drivers for TATA and ASHOK LEYLAND respectively, and too low (low mismatch) for 93% of drivers for ISUZU. We found that SH was appropriate for only 29%, 2%, and 7% for the drivers for the truck brands TATA, ASHOK LEYLAND, and ISUZU respectively. Because of the high mismatch between SH and PH, drivers were not able to support their feet on the horizontal surface below the driving seat. This might lead to an increase in the load on the lower legs and cause lower back pain due to prolonged driving in this position. Milanese and Grimmer<sup>34</sup> also found an increase in tissue pressure of the knee because of this high mismatch. On the other hand, the low mismatch might force to fold the leg which increases the pressure on knee and soft hip region.

The mismatch analysis showed that the SW was acceptable for 67% and 51% of the drivers for TATA and ASHOK LEYLAND respectively. In case of ISUZU, SW was suitable only for 16% of the drivers. The SW was too wide (high mismatch) for the majority of drivers (84%) for ISUZU; the SW was too wide for 27% and 47% of drivers and too narrow (low mismatch) for nearly 6% and 2% drivers for TATA and ASHOK LEYLAND respectively. The narrower SW compared to HB might compress the soft hips which induces extra stress on the hip

**Table 2.** Dimensions (cm) of existing truck driver seats of three brands (n=30 each brand)

Seat dimension	Mean	St. Dev.	Percentile (%)		
			5th	50th	95th
<b>TATA</b>					
Seat height	47.3	0.2	47.0	47.3	47.5
Seat width	46.2	0.2	46.0	46.2	46.5
Seat depth	38.2	0.2	38.0	38.2	38.5
Backrest height	48.3	0.2	48.0	48.3	48.6
Steering wheel clearance	16.7	0.2	16.6	16.7	16.9
Back support to steering wheel	36.8	0.1	36.7	36.8	36.8
Back support to front of steering wheel	81.2	0.1	81.2	81.2	81.3
<b>ASHOK LEYLAND</b>					
Seat height	51.3	0.2	51.0	51.3	51.5
Seat width	48.3	0.2	48.0	48.4	48.6
Seat depth	44.2	0.2	44.0	44.2	44.5
Backrest height	47.2	0.2	47.0	47.2	47.5
Steering wheel clearance	12.7	0.1	12.5	12.7	12.9
Back support to steering wheel	37.4	0.2	37.2	37.5	37.5
Back support to front of steering wheel	83.7	0.1	83.6	83.7	83.8
<b>ISUZU</b>					
Seat height	36.3	0.2	36.0	36.3	36.6
Seat width	52.4	0.3	52.1	52.4	52.6
Seat depth	41.4	0.3	41.1	41.4	41.7
Backrest height	45.3	0.2	45.0	45.4	45.6
Steering wheel clearance	14.1	0.2	14.0	14.2	14.2
Back support to steering wheel	35.5	0.1	35.5	35.5	35.6
Back support to front of steering wheel	78.7	0.1	78.6	78.7	78.7

region and causes mobility restrictions. On the other hand, too wide SW might affect esthetics and space economy which are not expected for optimal seat design.

The SD was too deep (high mismatch) for 16%, 79%, and 46% of the drivers for TATA, ASHOK LEYLAND, and ISUZU respectively, and was too shallow (low mismatch) for only 7% of the drivers for TATA. The SD was acceptable for 77%, 21%, and 54% of the drivers for TATA, ASHOK LEYLAND, and ISUZU respectively. Too shallow SD compared to BPL might not be able to support the thigh properly. This situation might cause a potential discomfort and unsteadiness for the drivers. In too large SD, drivers might need to sit with some portion of leg on the seat for backrest support. This sitting position might be responsible for extreme stress on that portion of the leg.

The BH was appropriate for 35%, 49%, and 72% drivers and large (high mismatch) for 65%, 51%, and 28% of drivers for TATA, ASHOK LEYLAND, and ISUZU respectively. The high mismatch between BH and SSH might increase compression in the scapula and restrict the

drivers' arm mobility while, low mismatch might create back pain, and neck pain.

Table 4 shows that the SWC was inappropriate for all (100%) drivers for ASHOK LEYLAND and 53% and 88% drivers for TATA and ISUZU respectively. The higher SWC compared to TC might permit comfortable movement of the drivers' thighs and lower legs. However, too high SWC might create stress on the elbow.

The mean AD ( $26.35 \pm 2.4$  cm) was smaller than its counterpart (i.e., the BSSW for all three truck bands; Table 1 and Table 2). Hence, the drivers might not face any obstacle by the steering wheel for proper sitting. On the contrary, the mean AL ( $76.77 \pm 1.5$  cm) was marginally lower than BSFSW for the truck bands.

### 3.2. Recommended seat dimensions

In this current study, common seat dimensions were proposed for the three types of trucks based on the drivers' anthropometry to ensure a match of the seats with the drivers' body dimensions. The newly proposed optimal seat dimensions appropriate for Bangladeshi drivers are

**Table 3.** T-test analysis of anthropometric dimensions and seat dimensions of the three brands

Anthropometric measurements			Seat dimensions			t <sub>cal.</sub>	t <sub>cri.</sub>	P value
Mean	St. Dev.		Mean	St. Dev.				
<b>TATA</b>								
Popliteal height	43.4	2.5	Seat height	47.3	0.2	16.9	2.0	<0.00001
Hip breadth	37.7	3.0	Seat width	46.2	0.2	31.5	2.0	<0.00001
Buttock popliteal length	43.8	3.0	Seat depth	38.2	0.2	20.2	2.0	<0.00001
Sitting shoulder height	59.0	3.6	Backrest height	48.3	0.2	32.3	2.0	<0.00001
Thigh clearance	14.6	1.8	Steering wheel clearance	16.7	0.2	12.5	2.0	<0.00001
<b>ASHOK LEYLAND</b>								
Popliteal height	43.4	2.5	Seat height	51.3	0.2	34.1	2.0	<0.00001
Hip breadth	37.7	3.0	Seat width	48.3	0.2	39.1	2.0	<0.00001
Buttock popliteal length	43.8	3.0	Seat depth	44.2	0.2	1.4	2.0	0.163606
Sitting shoulder height	59.0	3.6	Backrest height	47.2	0.2	35.6	2.0	<0.00001
Thigh clearance	14.6	1.8	Steering wheel clearance	12.7	0.1	11.7	2.0	<0.00001
<b>ISUZU</b>								
Popliteal height	43.4	2.5	Seat height	36.3	0.2	30.5	2.0	<0.00001
Hip breadth	37.7	3.0	Seat width	52.4	0.3	53.7	2.0	<0.00001
Buttock popliteal length	43.8	3.0	Seat depth	41.4	0.3	8.8	2.0	<0.00001
Sitting shoulder height	59.0	3.6	Backrest height	45.3	0.2	41.4	2.0	<0.00001
Thigh clearance	14.6	1.8	Steering wheel clearance	14.1	0.2	3.0	2.0	0.003169

**Table 4.** Match/mismatch percentages for drivers

Seat dimensions	Match	Low mismatch	High mismatch	Total mismatch
<b>TATA</b>				
Seat height	29	0	71	71
Seat width	67	6	27	33
Seat depth	77	7	16	23
Backrest height	35	0	65	65
Steering wheel clearance	47	-----	-----	53
<b>ASHOK LEYLAND</b>				
Seat height	2	0	98	98
Seat width	51	2	47	497
Seat depth	21	0	79	79
Backrest height	49	0	51	51
Steering wheel clearance	0	-----	-----	100
<b>ISUZU</b>				
Seat height	7	93	0	93
Seat width	16	0	84	84
Seat depth	54	0	46	46
Backrest height	72	0	28	28
Steering wheel clearance	12	-----	-----	88

shown in Fig. 4. The match/mismatch percentage of these optimum seat dimensions maximized the match percent-

age and minimized the mismatch percentages as demonstrated in Table 4. It is evident from Table 5 that the

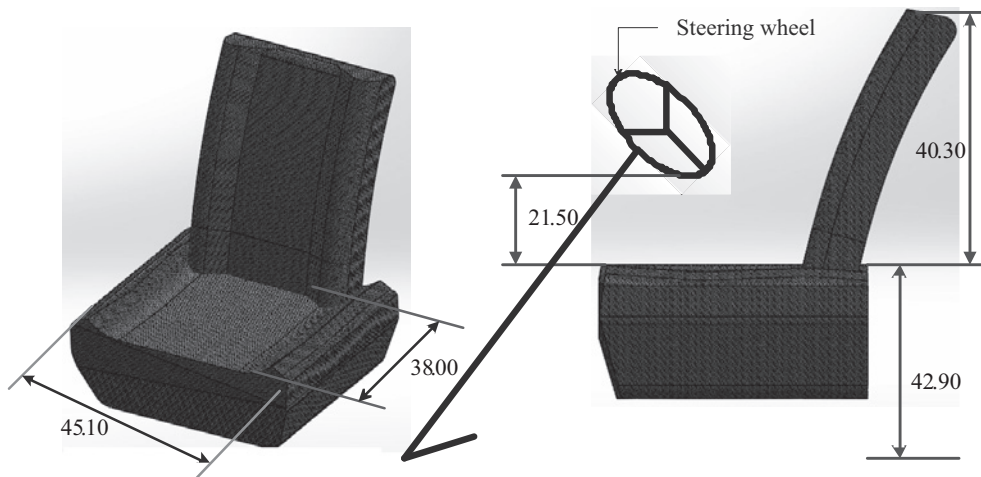

Fig. 4. Proposed seat dimensions (cm) for Bangladeshi truck drivers

Table 5. Proposed seat dimensions (cm) and match/mismatch percentages for drivers

Seat dimensions	Dimension	Match	Low mismatch	High mismatch	Total mismatch
Seat height	42.9	82	10	8	18
Seat width	45.1	76	10	14	24
Seat depth	38.0	79	10	11	21
Backrest height	40.3	98	0	2	2
Steering wheel clearance	21.5	100	0	0	0
Backrest angle to horizontal	95°				
Seat angle to horizontal	0°				

newly proposed dimensions better matched the drivers' anthropometric data with the percentages of 82% for SH, 76% for SW, 79% for SD, 98% for BH, and 100% for SWC. The proposed SH was not appropriate only for 18% of drivers and the SD was not comfortable for 21% of drivers. In addition, SW was unsuitable for 24% and backrest height was not properly fit for only 2% of the drivers.

It is clear from our analysis that in case of TATA, the percentage mismatch was decreased by 53% for SH, 2% for SD, 9% for SW, 53% for SWC, and 63% for BH (Fig. 5). For ASHOK LEYLAND brand, the percentage mismatch was decreased by 80% for SH, 58% for SD, 25% for SW, 100% for SWC, and 49% for BH. For ISUZU, the proposed dimensions reduced about 75%, 25%, 60%, 88%, and 27% of mismatch for SH, SD, SW, SWC, and BH, respectively. This increased match will help to improve the sitting posture of the drivers and therefore reduce their physical problems.

The results of this study suggest that the design of seat dimension should be based on the anthropometric data of the user population. However, the variation of anthropometric characteristics of different populations across countries makes it difficult for designers to design an er-

gonomically correct seat. Therefore, to develop the most generalized design guidelines, linear regression analysis was conducted to establish the relationship between the drivers' anthropometry and seat dimensions. The equations can be used for predicting seat dimensions as illustrated in Table 6. Each of the seat measurements can be determined using only the stature of the population as an independent variable.

#### 4. Conclusion

Prolonged driving on an ergonomically unfit seat exposes truck drivers to numerous health problems. The current study places emphasis on the use of anthropometric data for designing ergonomically correct seats. The current study was limited to three truck brands (i.e., TATA, ASHOK LEYLAND, and ISUZU) and drivers from the Khulna region of Bangladesh. The relationship between the seat dimensions of existing trucks and the drivers' anthropometric data showed a substantial mismatch. The study derived the optimal seat dimensions by statistical modeling. Appropriate dimensions for the truck seats are expected to reduce the mismatch and provide a safe and comfortable driving environment by reducing



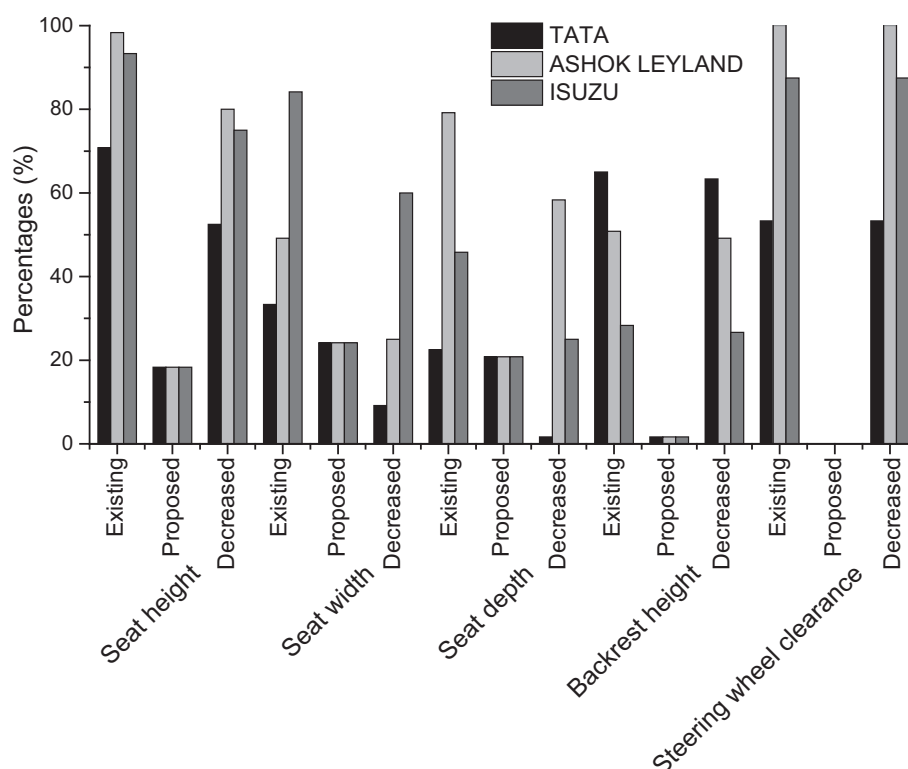

**Fig. 5.** Mismatch percentages of different dimensions for truck brands

**Table 6.** Linear regression between each seat dimension and stature of the driver

Dependent variables (Y)	Calculated equations
Seat height (Popliteal height)	$Y=0.1+0.2\times Stature$
Seat width (Hip breadth)	$Y=31.8+0.1\times Stature$
Seat depth (Buttock popliteal length)	$Y=-5.8+0.3\times Stature$
Backrest height (Sitting shoulder height)	$Y=22.6+0.2\times Stature$
Steering wheel clearance (Thigh clearance)	$Y=10.6+0.1\times Stature$

drivers' health issues and increasing their comfort level. The current study can be used to develop guidelines for the design of truck seats for Bangladeshi drivers.

*Conflicts of interest:* The authors declare that they have no conflict of interest.

## References

- Westgaard RH, Aarås A. Postural muscle strain as a causal factor in the development of musculo-skeletal illnesses. *Appl Ergon* 1984; 15: 162-174.
- Peteri V. Bad enough ergonomics: A case study of an office chair. *SAGE Open* 2017; 7: 1-11.
- Bolstad G, Benum B, Rokne A. Anthropometry of Norwegian light industry and office workers. *Appl Ergon* 2001; 32: 239-246.
- Mahoney JM, Kurczewski NA, Froede EW. Design method for multi-user workstations utilizing anthropometry and preference data. *Appl Ergon* 2015; 46: 60-66.
- Vyavahare RT, Kallurkar SP. Anthropometry of male agricultural workers of western India for the design of tools and equipments. *Int J Ind Ergon* 2016; 53: 80-85.
- Wilder D, Magnusson ML, Fenwick J, Pope M. The effect of posture and seat suspension design on discomfort and back muscle fatigue during simulated truck driving. *Appl Ergon* 1994; 25: 66-76.
- Ghaderi E, Maleki A, Dianat I. Design of combine harvester seat based on anthropometric data of Iranian operators. *Int J Ind Ergon* 2014; 44: 810-816.
- Hiemstra-van Mastrigt S, Kamp I, van Veen SAT, Vink P, Bosch T. The influence of active seating on car passengers' perceived comfort and activity levels. *Appl Ergon* 2015; 47: 211-219.
- Ozsoy B, Ji X, Yang J, Gragg J, Howard B. Simulated effect

- of driver and vehicle interaction on vehicle interior layout. *Int J Ind Ergon* 2015; 49: 11-20.
- 10) Kovačević S, Vučinić J, Kirin S, Pejnović N. Impact of anthropometric measurements on ergonomic driver posture and safety. *Period Biol* 2010; 112: 51-54.
  - 11) Ciloglu H, Alziadeh M, Mohany A, Kishawy H. Assessment of the whole body vibration exposure and the dynamic seat comfort in passenger aircraft. *Int J Ind Ergon* 2015; 45: 116-123.
  - 12) Filtness AJ, Mitsopoulos-Rubens E, Rudin-Brown CM. Police officer in-vehicle discomfort: appointments carriage method and vehicle seat features. *Appl Ergon* 2014; 45: 1247-1256.
  - 13) Mehta CR, Gite LP, Pharade SC, Majumder J, Pandey MM. Review of anthropometric considerations for tractor seat design. *Int J Ind Ergon* 2008; 38: 546-554.
  - 14) Ajayeoba AO, Adekoya LO. Evaluation of the ergonomic suitability of passenger seats in molue buses in Nigeria. *J Mech Eng* 2012; 1: 4-11.
  - 15) Márquez MA, Garcia JM. Ergonomics of urban public passengers transportation. In: 9th Annual Applied Ergonomics Conference 2006.
  - 16) Mazloumi A, Mohammadreza F. Ergonomic evaluation of interior design of Shoka vehicle and proposing recommendations for improvement. *Work* 2012; 41: 1477-1485.
  - 17) Ismaila SO, Akanbi OG, Adekunle NO, Adetunji OR, Kuye SI. An ergonomics assessment of passenger seats in buses in South Western Nigeria. *Sigumost* 2010; 52: 329-334.
  - 18) Jahns SK, Reed MP, Hardee HL. Methods for in-vehicle measurement of truck driver postures. In: SAE Technical Paper; 2001.
  - 19) Tan CF, Chen W, Delbressine FLM, Rauterberg GWM. Objectifying discomfort seat measurement for next generation truck driver's seat. In: FISITA World Automotive Congress. Munich, Germany; 2008.
  - 20) Onawumi AS, Lucas EB. Ergonomic investigation of occupational drivers and seat design of taxicabs in Nigeria. *ARPN J Sci Technol* 2012; 2: 214-220.
  - 21) Zhou Q, Liu Z, Xie F, Zheng S, Zhou S. Measurement and analysis of Anthropometric parameters of young male vehicle drivers. In: Duffy VG, editor. *Digital human modeling applications in health, safety, ergonomics and risk management*. Cham: Springer International Publishing; 2014. p. 174-181 (Lecture Notes in Computer Science; vol. 8529).
  - 22) Hicks C. *Research methods for clinical therapists: applied project design and analysis*. Churchill Livingstone/Elsevier; 2009. p. 406.
  - 23) Pheasant S, Haslegrave CM. *Bodyspace: Anthropometry, Ergonomics and the Design of Work*. Third Edition. CRC Press; 2005. p. 352.
  - 24) Abeysekera JDA. Design requirements and dimensions for a comfortable work seat for Sri Lanka. *J Natl Sci Found Sri Lanka* 1985; 13: 77-88.
  - 25) Chakraborty RK, Asadujjaman M, Nuruzzaman M. Fuzzy and AHP approaches for designing a hospital bed: a case study in Bangladesh. *J. Industrial and Systems Engineering* 2014; 17: 315-328.
  - 26) ISO 7250. Basic human body measurements for technological design—part 3: worldwide and regional design ranges for use in product standards. 2013.
  - 27) Castellucci HI, Catalál M, Arezes PM, Molenbroek JFM. Evaluation of the match between anthropometric measures and school furniture dimensions in Chile. *Work* 2016; 53: 585-595.
  - 28) Molenbroek JFM, Kroon-Ramaekers YMT, Snijders CJ. Revision of the design of a standard for the dimensions of school furniture. *Ergonomics* 2003; 46: 681-694.
  - 29) Parcels C, Stommel M, Hubbard RP. Mismatch of classroom furniture and student body dimensions: empirical findings and health implications. *J Adolesc Health* 1999; 24: 265-273.
  - 30) Gutiérrez M, Morgado P. Guide recommendations for the design of school furniture. 2001.
  - 31) Evans WA, Courtney AJ, Fok KF. The design of school furniture for Hong Kong school children. *Appl Ergon* 1988; 19: 122-134.
  - 32) Helander M. Anthropometry in workstation design. In: Helander M, editor. *A Guide to the Ergonomics of Manufacturing*. London: Taylor and Francis; 1997. p. 17-28.
  - 33) Pheasant S. *Ergonomics, Work and Health*. Aspen Publishers; 1991.
  - 34) Milanese S, Grimmer K. School furniture and the user population: an anthropometric perspective. *Ergonomics* 2004; 47: 416-426.
  - 35) Osborne DJ. *Ergonomics at Work: Human Factors in Design and Development*. Wiley; 1995. p. 462.
  - 36) Oyewole SA, Haight JM, Freivalds A. The ergonomic design of classroom furniture/computer work station for first graders in the elementary school. *Int J Ind Ergon* 2010; 40: 437-447.
  - 37) Poulakakis G, Marmaras N. A model for the ergonomic design of office. In: Scott PA, Bridger RS, Charteris J, editors. *Ergonomics Conference in Cape Town*. Global Ergonomics Elsevier; 1998. p. 500-504.
  - 38) Gouvali MK, Boudolos K. Match between school furniture dimensions and children's anthropometry. *Appl Ergon* 2006; 37: 765-773.
  - 39) Agha SR. School furniture match to students' anthropometry in the Gaza Strip. *Ergonomics* 2010; 53: 344-354.
  - 40) García-Acosta G, Lange-Morales K. Definition of sizes for the design of school furniture for Bogotá schools based on anthropometric criteria. *Ergonomics* 2007; 50: 1626-1642.
  - 41) Chimote K, Gupta M. Integrated approach of ergonomics and fem into truck drivers seat comfort. In: 1st International and 16th National Conference on Machines and Mechanisms. India: IIT Roorkee; 2013. p. 183-188.
  - 42) Powar K, Majumdar S, Unakal P. Interior design of long haul truck cabin for improved Ergonomics and Comforts. *SASTECH Journal* 2009; 8: 47-54.