

Some Reflections on the Mechanism of Renal Tubular Potassium Transport¹

GERHARD GIEBISCH

Department of Physiology, Yale University School of Medicine, New Haven, Connecticut 06510

Received May 8, 1975

Analysis of the driving forces acting on the movement of potassium across individual membranes of tubule cells shows that both active and passive components play an important role in the regulation of potassium transport. Distal and cortical collecting tubule and papillary collecting duct elements are the key nephron sites participating in a complex fashion to translate a wide variety of metabolic challenges into the appropriate excretory response. The latter involves both secretory and reabsorptive activity.

The analysis of the factors modulating tubular potassium transfer has shown that the potassium concentration in the cells of the distal nephron is a key factor regulating the rate of and the direction of potassium transfer. Factors involved in setting the cellular potassium concentration are active potassium uptake at the peritubular and luminal membrane of the cells as well as electrogenic sodium extrusion across the peritubular boundary of the cells. Additional factors regulating potassium transport involve the electrical potential difference, sensitive to changes in the sodium concentration in the lumen, the flow rate past the late distal tubular site of potassium secretion, and the activity of a reabsorptive potassium pump in the luminal membranes of the cells. In the cortical collecting tubule, active potassium secretion is also present at the luminal membrane of the cell, but the role of such an additional secretory mechanism in the late distal tubule is presently unknown. Most of these individual transport mechanisms exist along the whole distal nephron, but their relative prominence varies among the late distal tubule, the cortical collecting tubule, and the papillary collecting duct.

INTRODUCTION

This essay is an attempt at a critical reassessment of our present concepts of tubular potassium transport. Several reviews have recently appeared on the topic of potassium transfer by the renal tubule and should be consulted for a detailed description of the nephron sites, sources of and mechanisms controlling renal potassium excretion (11, 27, 33, 61, 82). Based on this background information and after a brief consideration of the historical development that led to presently held views on this topic, this discussion will focus on some newer and controversial aspects of renal tubular potassium transfer and critically analyze present state of knowledge of this topic.

HISTORICAL BACKGROUND

With the introduction and use of renal clearance methods, it became well established that under conditions of normal or reduced dietary potassium intake, the rate of renal potassium excretion is much less than the rate at which this ion is filtered across the glomerulus. A priori one might have assumed that urinary potassium excretion is determined by the magnitude of and by variations in the rate of potassium reabsorption by the renal tubules. However, the possibility that net

¹Work in the author's laboratory was supported by grants from the NIH, NSF, and the American Heart Association.

transfer of potassium may also proceed in the opposite, that is, in the secretory direction, was suggested by observations that at low rates of glomerular filtration of potassium, the amount of potassium in the final urine may exceed the amount of potassium filtered (36, 48). These findings were soon confirmed and stimulated a series of experimental studies by Berliner and Mudge and their associates (3, 4, 5, 51, 52, 53) in the late 1940s and early 1950s that firmly established that a portion of the excreted potassium may be secreted by the tubules, particularly when glomerular filtration rate is low or urine flow rate enhanced by infusion of hypertonic urea or bicarbonate solutions. Since maintenance of potassium balance in humans and animals on a normal potassium diet does not require more than 10–20% of the filtered potassium load to escape tubular reabsorption and to be excreted into the urine, the newly established secretory mechanism of potassium was first viewed as a sort of reserve mechanism, called upon only when adequate urinary potassium excretion was jeopardized (2).

Renal clearance methods have inherent shortcomings with respect to providing accurate and incisive results concerning the relative contributions of the spatially separated, simultaneously occurring processes of reabsorption and secretion to the excreted moiety of potassium. Nevertheless, the use of these methods by Berliner's and Mudge's groups soon confirmed a suggestion by Gilman that most of the potassium excreted derives from secretion, even under conditions of normal intake (i. e., when urinary excretion rates constitute but a moderate fraction of that filtered) (2, 6). Essentially, this view was based on the remarkable insensitivity of urinary potassium excretion to significant alterations of its filtered moiety. Thus, as long as urinary sodium excretion was maintained at near normal levels, the filtered load of potassium could be reduced by about one-third without producing marked differences in the rate of urinary potassium excretion (18). This is in sharp contrast to the renal handling of sodium ions where a similar acute drop in filtered sodium load leads to a sharp reduction of its excretion rate (18, 71). It was correctly deduced from the demonstrated dramatic dissociation of filtered from excreted potassium moieties that the observed constant excretion rates resulted from "distal" secretion of a fixed amount of potassium into tubular fluid that had passed along "proximal" nephron sites where it had been rendered virtually potassium-free by a powerful, nonsaturable reabsorptive mechanism. According to this view, potassium secretion at some distal nephron site was the main source of urinary potassium. It was also thought to be the nephron site that responded to metabolic disturbances with the appropriate adjustment of tubular potassium transport. Such an adjustment could not only involve varying rates of tubular potassium secretion but could also include a reversal of the direction of transport, i. e., potassium reabsorption. Thus, the distal nephron emerged from these considerations as the main control site of renal potassium excretion.

Additional evidence for the secretory source of urinary potassium was afforded by results from stop-flow experiments (47, 55, 61, 72, 73) in which, under suitable conditions, potassium accumulates in more distal samples, i. e., those fractions that emerge first after release of the ureteral clamp. This observation underscored the notion that potassium secretion occurs at nephron sites distal to those involved in its reabsorption. Finally, the observation that after injection of radioactive potassium (^{42}K), the specific activity of urinary potassium approached that of potassium in renal tubular tissue, and that this was quite different from the specific activity of arterial plasma from which the glomerular filtrate is derived, is also relevant to the mode of potassium transfer (8, 49). This finding demonstrates both the inde-

pendence of the urinary specific activity of potassium from that of the filtered and the involvement of rapidly exchanging cellular potassium stores in the process of potassium secretion.

Clearance experiments also provided the first hints for a more general concept of cellular potassium transport that explained many aspects of tubular potassium transfer. The following were the main points:

1) Since there was no evidence for tubular anion secretion, it was postulated that the secretory movement of potassium must occur by a process of cation exchange. Sodium ions were the most likely candidate since no other cation is available in adequate amounts (2).

2) This tubular exchange of sodium for potassium implied a sensitivity of the process of potassium secretion to the availability of sodium ions at secretory distal nephron sites. Accordingly, it was anticipated that if sodium delivery to the site of potassium secretion were reduced below a critical level, it could become rate-limiting for potassium secretion. This prediction of a critical role of sodium ions in the process of tubular potassium secretion has been borne out by several experimental observations that an acute reduction of urinary sodium excretion may sharply depress the rate of renal potassium excretion (2, 6, 11, 18, 27, 34).

3) Finally, the clearance approach to the study of renal potassium secretion has also defined some important relationships between the process of urinary acidification and that of potassium secretion. In general, alkalization of the urine is frequently found to produce kaliuresis (2, 5, 11, 27, 42, 57, 82), whereas potassium deficiency accelerates hydrogen ion secretion by the kidney (57). In contrast, acute acidosis depresses potassium excretion (20, 42, 57), although prolonged maintenance of either acidotic or alkalotic conditions leads to a more complex pattern of potassium excretion (25). Nevertheless, these findings implied some reciprocity between the distal tubular transport rates of hydrogen and potassium ions and, in particular, linked changes in cellular potassium transport to the acid-base status of distal tubule cells.

Two recent developments have further contributed to our understanding of the process involved in the regulation of renal tubular potassium transport. These methods have in common the study of potassium transport at the single nephron level. First, the application of micropuncture techniques to the study of tubular potassium transport has made possible a more direct appraisal of the suggested nephron sites of reabsorption, of secretion, and of the proposed transport mechanisms. Second, the successful isolation and perfusion of tubular segments *in vitro* has extended the study of potassium transport in single nephrons to those parts of the nephron that are not accessible to puncture from the kidney surface, including the loop of Henle and, in particular, the cortical collecting tubule. Also, it is obvious that the extensive functional isolation of the tubular epithelium *in vitro* is difficult to achieve *in vivo*, although significant progress has been achieved by the simultaneous perfusion of tubules and peritubular capillaries with solutions of widely varying compositions. This has made possible, even *in vivo*, a fairly detailed and incisive analysis of the processes underlying tubular potassium transport.

SEGMENTAL TRANSPORT PATTERNS OF POTASSIUM ALONG THE NEPHRON

Micropuncture and microperfusion studies have fully confirmed the importance of distal tubular secretion as the main source of urinary potassium. The same nephron sites have also been firmly established as the main control site of potassium

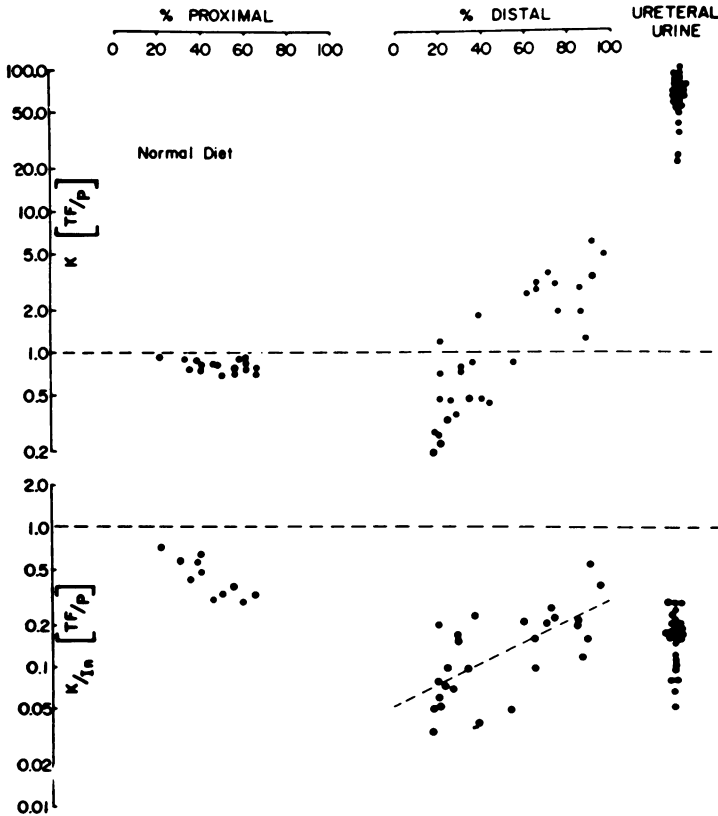

FIG. 1. Summary of potassium and potassium-to-inulin concentration ratios from rats on control diet. Upper panel: tubule fluid-to-plasma concentration ratios along the nephron. Lower panel: potassium-to-inulin concentration ratios along the nephron. These values represent the fraction of filtered potassium remaining within the lumen at varying sites along the proximal and distal tubule. Urinary values are also included. (From Ref. 44.)

excretion. Figures 1–3 provide information on the range of potassium concentrations as well as the range of fraction of the filtered potassium remaining at various points along the nephron (44). From inspection of these figures it is clear that despite an over hundredfold range of urinary fractional excretion rates of potassium, brought about by potassium deprivation or by a stimulation of potassium excretion, neither proximal tubular potassium concentration ratios nor the rates of fractional potassium reabsorption along the proximal tubule differ (44, 45). Thus, the very extensive range of urinary potassium excretion does not result from modifications in proximal tubular potassium transport but depends on the magnitude of the distal tubular secretory process. It is only after osmotic diuresis (44), administration of diuretics such as furosemide that act at the ascending thick limb of Henle's loop (15, 22, 50), or extensive depression of proximal tubular fluid transport such as that observed after extensive extracellular volume expansion (10, 17, 38, 41) that the delivery of larger than normal fluid and potassium loads into the distal tubule contributes significantly to the kaliuresis (27, 39, 40). In all other situations studied, the rate of urinary potassium excretion depends solely on the magnitude of the secretory potassium movement that occurs along the distal tubule or at tubule sites beyond this nephron segment.

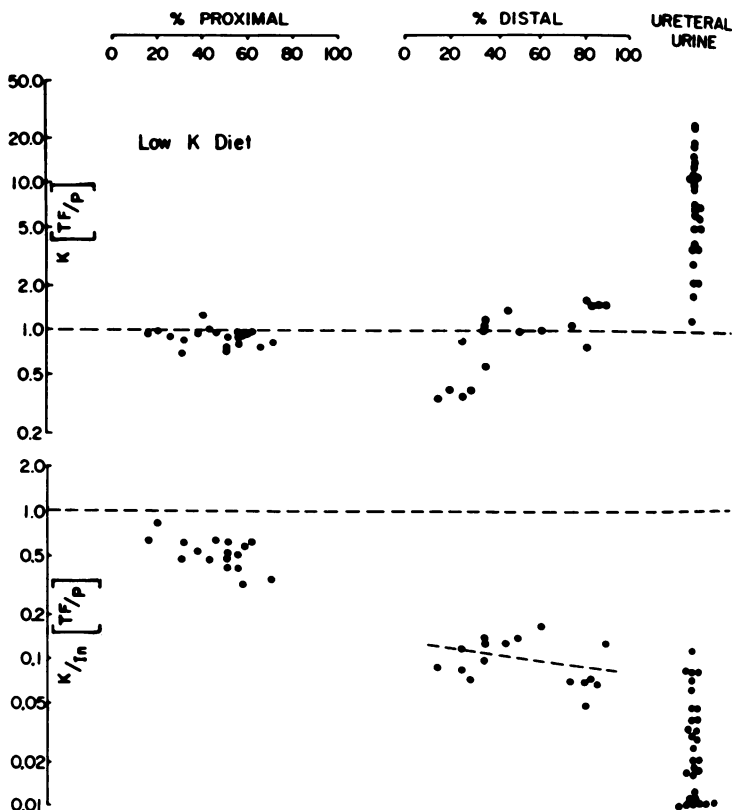

FIG. 2. Summary of potassium and potassium-to-inulin concentration ratios as function of nephron length in animals kept on a low potassium diet for several weeks. (From Ref. 44.)

Both the distal tubular epithelium as well as that of the collecting duct epithelium are also able to effect extensive net reabsorption of potassium. This is apparent from the decline of $TF/P \text{ K}/In$ ratios along the distal tubule in potassium-deprived animals and the frequent observation that the amounts of potassium in the final urine may be significantly less than those present at late distal tubular sites. Thus, dietary deprivation of potassium or sodium has been shown to stimulate potassium reabsorption along the collecting ducts (21, 44, 45). Complete suppression of potassium secretion along the distal tubule can also be achieved by potassium-sparing drugs such as amiloride (22). Net potassium reabsorption, not secretion, is commonly observed to take place along the distal tubule of those aquatic amphibians that have been studied (78). However, just like the mammalian distal tubule, amphibian tubules are also endowed with the ability to secrete potassium. When exposed to a high potassium environment or to the carbonic anhydrase inhibitor acetazolamide, a maneuver that stimulates distal potassium secretion in mammals (44), distal tubules of *Amphiuma* respond with dramatic net secretion of potassium (78).

UNCERTAINTIES ABOUT THE TUBULAR SITES OF POTASSIUM SECRETION

Most studies of potassium transport *in vivo* have been carried out on rat tubules, a species in which the distal tubule is well developed. Morphological evidence indi-

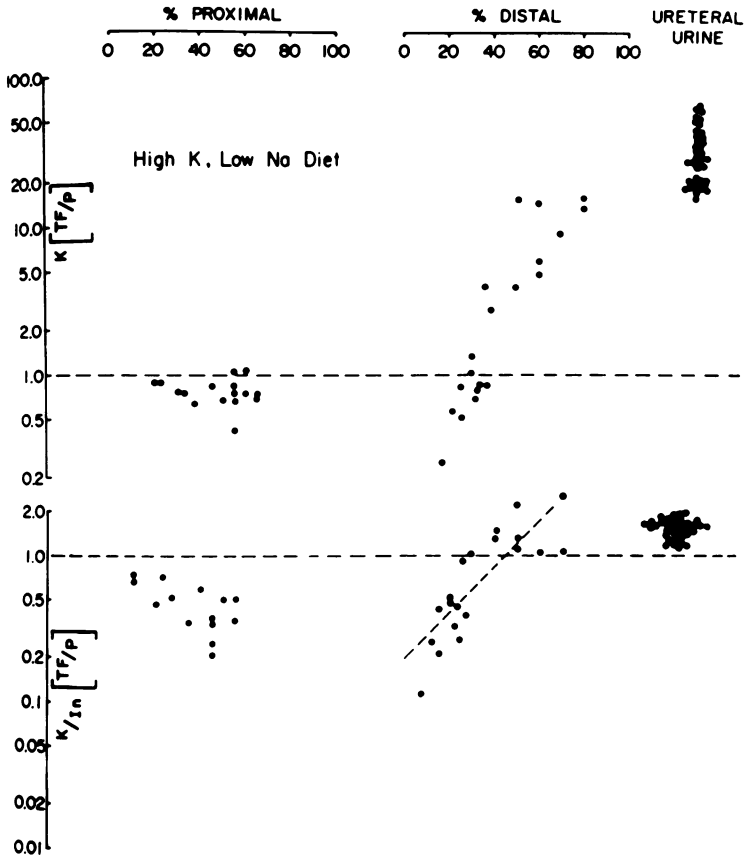

FIG. 3. Summary of potassium and potassium-to-inulin concentration ratios in animals in which urinary potassium excretion had been maximally stimulated. (From Ref. 44.)

cates that the distal tubule is a transitional nephron segment in which a variable number of tubule cells with the typical appearance of collecting tubule cells are also present (70, 79). It is presently not at all clear if such morphological heterogeneity plays a functional role, i.e., whether, for instance, all late distal tubular cells, irrespective of their appearance, participate in potassium secretion or not. It is conceivable that only some do and that in functional states that are associated with prolonged stimulation of distal tubular potassium transport, such as a chronic high potassium intake or metabolic alkalosis, additional cellular elements are recruited into the secretory process. Striking morphological changes at the late distal tubular level have been observed in situations in which the tubular fluid is alkalinized (58, 59), but the relevance of these studies to the problem of distal tubular potassium transport is not clear at all.

Another problem concerns the possibility that the distal tubule may not be the main site of potassium secretion in some species. This could be the case in species such as the rabbit, in which the distal tubule is short and makes up only a small fraction of the nephron. It is also possible that in species in which some properties of the late distal tubule epithelium differ from that found in the rat also differ with respect to their ability to secrete potassium. A relevant example is the dog, in which hypotonic early distal tubular fluid does not become isotonic by the time it reaches

the end of the distal tubule (16). This contrasts with the behavior in the rat and implies a low water permeability. Whether in such species, in which a high water permeability resides further downstream, potassium secretion still occurs along the distal tubule or, alternatively, is also shifted to the cortical collecting tubule is presently not known. Although the dog distal tubule does secrete potassium (11), its functional behavior with respect to potassium transport has not been as extensively studied as in the rat. Thus, the distribution of potassium secretion between the distal tubule and sites beyond it remains uncertain in species other than those rodents in which this problem has been extensively studied.

However, even in the rat, in which the distal tubule has clearly emerged as the main nephron site of potassium secretion, nephron sites beyond the distal tubule can make large contributions to urinary potassium secretion. Thus, not only during states of exogenous potassium loading can the collecting duct epithelium contribute, albeit moderately, to the overall secretory process, but in two other situations has the collecting duct been shown to be the main site of potassium secretion. First, pretreatment with a low sodium diet sensitizes rats to an acute potassium load so that they excrete this potassium load about 50% faster than animals on a normal sodium intake (54, 84). This enhancement of renal potassium excretion is largely due to increased net secretion by portions of the nephron beyond the distal tubule, i.e., the collecting duct epithelium. A similar situation obtains in the "remnant" kidney, i.e., a situation in which renal mass has been reduced by contralateral nephrectomy and additional ablation of renal tissue (1, 24). Again, augmentation of urinary potassium excretion in these animals is largely the result of increased secretion along the collecting duct segment.

From these considerations it is clear that the distal tubule and collecting duct both participate in the control of urinary potassium excretion, but further studies will be necessary to pinpoint the factors that specifically activate either the distal tubular epithelium or the collecting duct epithelium to augment its secretory rate. Some relevant factors will be discussed in the following.

CELLULAR MECHANISM OF RENAL TUBULAR POTASSIUM TRANSPORT

A consideration of the electrochemical potential differences across the individual cell barriers between the lumen of the tubule and the peritubular fluid compartment has permitted some insight into the transport mechanisms regulating potassium movement across the epithelium of both the distal tubule and the collecting tubule.

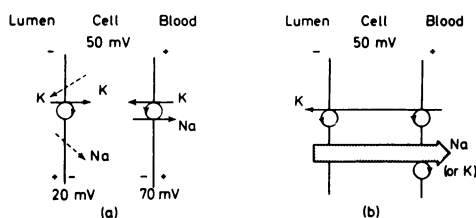

FIG. 4. Schematic representation of possible mechanisms of distal tubular and collecting tubule handling of potassium. Main difference between Model (a) and Model (b) is the presence of higher permeabilities to Na and K across the luminal membrane in Model (a) and the presence of an active reabsorptive pump at the luminal membrane of Model (a). Model (b) is distinguished by the presence of an active secretory K-pump at the luminal cell boundary. Note that active potassium uptake at the peritubular membrane is a common feature of both models. (From Ref. 82.)

Figure 4 provides a schematic presentation of transport mechanisms that are thought to be involved in potassium translocation across the distal nephron. Both models are supported by a considerable amount of experimental evidence, and it is likely that some or all features of Model (a) may be applicable to the distal tubular epithelium (of the rat), whereas Model (b) applies to the isolated collecting tubule (of the rabbit). Since the late portion of the distal tubule shares with the cortical collecting tubule some morphological features such as, for instance, the presence of dark, mitochondria-rich intercalated cells, a comparison of the two proposed transport mechanisms is of interest since it is possible that some of the transport elements may be present at both nephron sites.²

Na-K EXCHANGE ACROSS THE PERITUBULAR CELL MEMBRANE

Basic elements shared by both models are the transport mechanisms for sodium-potassium exchange localized within the peritubular membrane. Elements of Model (a) include as an important part an active component of potassium uptake localized both within the luminal *and* peritubular cell membrane. Active potassium accumulation is also a feature of Model (b). The activity of the peritubular Na-K pump is responsible for the establishment of a high intracellular potassium concentration. Its magnitude is thought to be one of the major factors determining the rate of potassium movement from cell to lumen across the luminal cell membrane. It is generally assumed that as in other animal cells, the active accumulation of potassium across the peritubular cell membrane is coupled to the extrusion of sodium from the cell interior to the peritubular fluid.

Recently, some properties of this peritubular potassium transport mechanism have been explored (19), and from a kinetic analysis using ⁴²K to measure unidirectional fluxes across individual membranes of the tubular cell, the peritubular potassium uptake has clearly emerged as a major site for the control of transepithelial potassium secretion (19, 29, 31, 78). Thus, it could be demonstrated that factors such as changes in the plasma level of potassium, acid-base alterations, and the carbonic anhydrase inhibitor Diamox affect potassium secretion primarily by acting on the rate of peritubular potassium uptake. Additional evidence is available to show that aldosterone also stimulates peritubular potassium uptake (75, 76). It is also quite likely that mercurial diuretics inhibit peritubular potassium transport (23).

Figure 5 summarizes the main kinetic parameters of distal tubular potassium transport in control, potassium-loaded, alkalotic, and potassium-deprived animals (19). It is apparent that compared to control conditions, the rate coefficients of luminal potassium exchange (k_{21} and k_{12}) are not significantly affected, whereas the flux ϕ_{21} , i.e., from cell to lumen, is attenuated in low-K animals and stimulated in high-K and alkalotic animals. Commensurate with the stimulation of tubular potassium secretion is the increase of S_2 , the amount of potassium labeled within cells under the different experimental conditions. This transport pool increases as a con-

²Four morphologically different segments make up the distal nephron (14, 70, 79): (a) the *thick ascending limb* of Henle's loop, or the cortical portion of the thick ascending limb of Henle's loop, shares morphological features of the medullary ascending limb but has thicker cells; (b) the *distal tubule*, morphologically and functionally a heterogeneous structure (being made up of the *early distal convoluted tubule* and being similar to the thick ascending limb of Henle) and the *late distal convoluted tubule* (being similar to the cortical collecting tubule); (c) the *cortical collecting tubule* extends from the junction of several distal tubules to the outer medulla and is unbranched; and (d) the *papillary collecting duct* extending into the medullary region and containing multiple branchings and a thicker epithelium than the cortical collecting tubule.

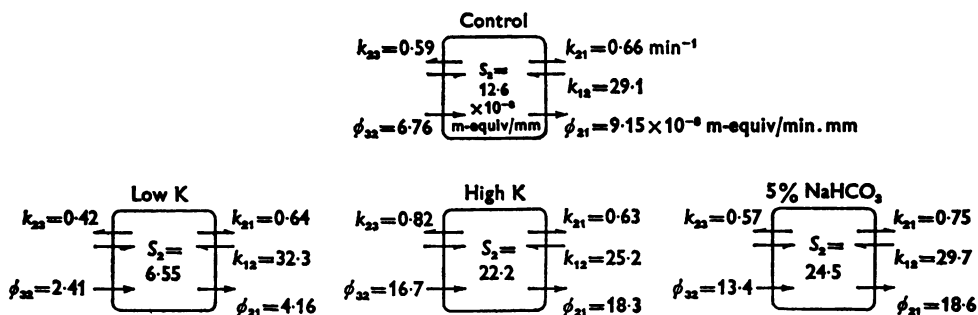

FIG. 5. Summary of main kinetic parameters of distal tubular potassium transfer in control, potassium-loaded, alkalotic, and potassium-deprived animals. For details, see text and caption for Fig. 6. (From Ref. 19.)

sequence of an augmentation of ϕ_{32} , i.e., the flux component of potassium transfer from peritubular fluid into the distal tubule cell. In contrast, during reduced net secretory movement in low-K animals, the uptake of potassium across the peritubular cell boundary is depressed and results in a reduction of the cellular transport pool of potassium. It is virtually certain that the directional changes of the potassium transport pool are paralleled by similar changes in cellular potassium concentrations. Independent evidence from studies using potassium-sensitive microelectrodes (37) and from measurements of the peritubular transmembrane potential difference (81) support the thesis that cellular potassium concentrations in distal tubules are elevated in potassium-loaded and alkalotic animals and reduced in low-potassium and acidotic animals.

An important conclusion from the kinetic analysis of potassium movement across individual tubular cell membranes is that the influx of potassium under the different experimental conditions into the tubular lumen varies widely without changes in the rate coefficients governing potassium transfer across the luminal cell membrane. Hence, it is rather by changes of the driving force acting on potassium transfer than by modifications of the transfer characteristics of the luminal cell membrane that potassium transport is regulated. Thus, the movement of potassium across the luminal cell membrane is critically controlled by changes in the cellular potassium content (S_2), which, in turn, is determined by modulation of the rate of potassium uptake across the peritubular cell membrane (ϕ_{32}). Figure 6 schematically summarizes the transport elements of a distal cell model that incorporates the features just discussed.

The active nature of peritubular potassium uptake has been inferred mainly on the basis of indirect evidence. The principal argument in support is the observation that potassium ions had to accumulate against a chemical concentration gradient since the peritubular potential difference of some 70 mV (cell negative) is not adequate to account for the concentration difference of potassium ions between cell compartment and extracellular fluid (26, 34). It should be realized that the actual concentrations of potassium in distal tubule cells are uncertain because distal tubule cells make up only a small fraction of renal tissue. Nevertheless, in a small number of electrolyte analyses in *Amphiuma* kidneys (68), in which proximal and distal tubules are topographically separate, there were no differences in potassium concentration between distal and proximal tubule cells.

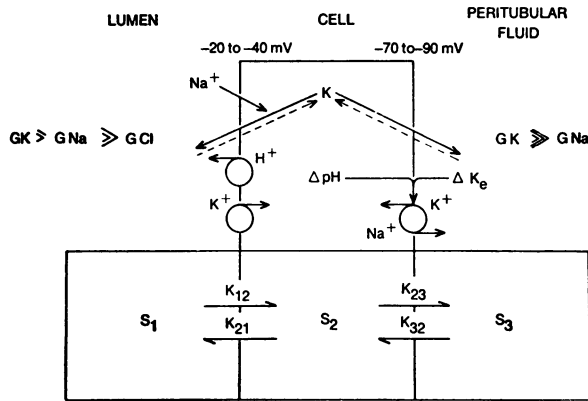

FIG. 6. A somewhat more detailed presentation of some properties of a single distal tubule cell. (a) Note different electrical polarization across the luminal and peritubular cell boundaries. (b) Sodium entry across the luminal cell membrane is facilitated by higher sodium permeability at this site than across the peritubular cell membrane. This process may include some carrier-mediated transfer. (c) The luminal cell membrane includes an active reabsorptive potassium pump. Whether this pump-driven potassium movement is coupled to other ion movement is unknown. (d) The luminal cell membrane is also the site of an active hydrogen ion pump. From the available evidence (42), it is unlikely that secretory movement of hydrogen and potassium are directly coupled. (e) The peritubular membrane has an active Na-K pump whose coupling ratio may vary. Evidence is available (11, 31, 34, 42) to suggest that cellular pH changes and alterations in extracellular potassium concentration as well as changes of the luminal Na concentration affect its pumping rate and electrogenicity.

Lower part: Schematic illustration of three-compartment system consisting of tubular lumen, the cell compartment, and peritubular fluid compartment. S_1 , S_2 , and S_3 denote amount of solute (K) in individual compartments; k_{12} , k_{21} , k_{32} , and k_{23} are rate coefficients defining unidirectional solute (K) movement across the luminal and peritubular cell membrane, respectively. (From Ref. 31.)

EVIDENCE FOR ELECTROGENIC SODIUM TRANSFER ACROSS THE PERITUBULAR CELL MEMBRANE

Recently, Khuri and his associates have analyzed, by means of cation-selective microelectrodes, the range of potassium activities in distal tubule cells of rat kidneys (37). They found potassium activities of only 40–50 mequiv/liter, a value very substantially lower than the chemically measured concentrations, implying that some potassium is chemically bound in an unknown manner. These cellular activities are low enough to allow for the possibility that potassium ions are passively driven into the cell since the magnitude of the electrical potential difference would suffice to establish these lower potassium activity differences. Also, if sodium extrusion were electrogenic, the potential difference generated by active sodium extrusion, possibly superimposed upon a potassium diffusion potential, could induce additional passive uptake of potassium ions across the peritubular membrane of the cells. Stated differently, this means that coupling of potassium accumulation to sodium extrusion would not be, as shown in Fig. 4 (a), by a carrier in which the movement of Na and K, in opposite directions, is carried out by the same mechanism. Rather, sodium ions tend to move from the cell to peritubular fluid at a higher rate than chloride (from cell to peritubular fluid) and also at a rate higher than potassium (from peritubular fluid into the cell). Thus, sodium extrusion is directly electrogenic and renders the cell interior electrically negative. This transport mechanism would be expected to drive potassium into the cell in a passive manner at a rate determined by both the passive resistance to potassium movement (potassium conductance) as

well as by the magnitude of the electrical potential difference generated by the sodium pump. Experimental evidence has clearly shown a high potassium permeability of the peritubular membrane of the cell (68), thus enhancing the efficiency of such a transport mode.

At the moment, critical evidence as to the precise contribution of such an electrogenic sodium transport system to the accumulation of potassium ions across the peritubular membrane of the cell is not available. Since changes in peritubular potassium uptake can occur without changes in polarization of the peritubular membrane, the presence of some electrically neutral Na-K exchange is strongly implied. On the other hand, participation of an electrically driven potassium uptake across the peritubular membrane and directly linked to active sodium extrusion is strongly suggested by a number of recent developments. Thus, electrophysiological evidence obtained in proximal tubule cells of *Necturus* (28, 69) and on guinea pig kidney slices (56, 74) clearly shows the capacity of the peritubular membrane to generate, during conditions of augmented sodium extrusion, a potential difference across the peritubular membrane significantly in excess of that to be expected from the transmembrane difference of potassium concentration (56). Such enhanced sodium extrusion may be brought about either by electrophoretic injection of sodium into single tubule cells (69) or by rewarming renal tissue that had been made sodium-rich by previous leaching in cold, low-K solutions. Since this potential difference was sensitive to ouabain and to lowering of the temperature, and since it correlates with active sodium transport, it is virtually certain that an electrogenic sodium pump was responsible for part of the cell polarization. These findings show clearly that potassium diffusion potentials are not the sole source of the electrical potential difference across the peritubular cell membrane.

The possibility that such a mechanism may also reside within distal tubule cells has recently become amenable to experimental exploration. Thus, when the luminal sodium concentration in *Amphiuma* distal tubules is abruptly increased, for instance, from 10 to 100 mequiv/liter, a rapid and highly significant increase of the peritubular transmembrane potential difference occurs (77). This response is abolished by ouabain. It is best explained by assuming stimulation of an electrogenic sodium extrusion mechanism residing within the peritubular membrane of the cell. Stimulation of electrogenic sodium extrusion would occur in response to the increase in cellular sodium concentration following elevation of the sodium gradient across the luminal cell membrane. Since the peritubular membrane of distal tubule cells has a relatively high potassium permeability (68), it is clear that an increase in cell negativity, following the elevation of the luminal and, by implication, the cellular sodium concentration, is a mechanism that passively augments the accumulation of potassium into tubule cells.

From these considerations it is clear that an electrogenic sodium extrusion mechanism, under the control of luminal and cellular sodium concentration changes, is part of the tubular mechanism that regulates cellular potassium concentration. On the other hand, in situations such as metabolic alkalosis (19), or after administration of acetazolamide (78), the influx of potassium into distal tubule cells increases sharply without changes in the peritubular potential difference. It can thus be "uncoupled" from electrogenic sodium movement and is, accordingly, affected by direct stimulation of an electrically neutral, most likely active, mode of potassium uptake (19).

The active nature of at least a fraction of distal tubular potassium transport is also supported by the demonstration of a metabolic link between renal potassium

transfer and the ATP-ase system. Elevated levels of this enzyme were found in rats chronically adapted to potassium (62). This enzymatic change could be dissociated from tubular sodium transport and seems closely associated with the increased rates of potassium secretion known to take place in rats chronically loaded with potassium (84).

It thus appears safe to conclude that both active, carrier-mediated as well as passive, electrically driven potassium movement takes place across the peritubular membrane of the cell. Both mechanisms appear to be involved in the regulation of potassium secretion. However, the precise contribution of changes in carrier-mediated or electrically driven potassium transport needs further exploration. As in other renal tubular segments (33), the coupling ratio of sodium-potassium exchange may vary under different experimental conditions. It is likely that, as in the proximal tubule (33), a "sliding" exchange ratio between sodium extrusion and potassium accumulation may also be present at the distal tubular level. This is strongly implied by the frequent observation that net sodium reabsorption and net potassium secretion can be effectively dissociated from each other and thus cannot be rigidly coupled. For instance, normally the rate of sodium reabsorption greatly exceeds that of distal potassium secretion (by at least an order of magnitude), and the apparent exchange ratio between sodium reabsorption and potassium secretion varies greatly, depending on the state of both the sodium reabsorptive and the potassium secretory systems (39, 40, 45). Only the measurement of unidirectional fluxes of sodium and potassium across the individual cell membranes will provide information with respect to the relationship between sodium and potassium movement and define its electrogenic properties.

PROPERTIES OF THE LUMINAL CELL MEMBRANE

Further inspection of Fig. 4 indicates important similarities and differences between the transport properties of the luminal and peritubular membranes. The luminal membrane shares with the peritubular membrane both a relatively high permeability to potassium (32, 43) and an active potassium pump oriented toward the cell interior (27, 34, 46). The presence of the latter is supported by the fact that net reabsorption of potassium against an electrochemical potential difference can be induced in the distal tubule in states of potassium deprivation (27). Potassium reabsorption occurs normally along the distal tubule of *Amphiuma* (78), an aquatic amphibian living in a fresh water habitat. Also, both steady-state and free-flow concentrations of potassium in the lumen of the distal convolution are usually below the level that should be maintained at electrochemical equilibrium (34, 46).³ Finally, administration of ouabain in rats (22, 65) and in *Amphiuma* (78) raises the luminal potassium concentration, an effect that could be due to blockade of a potassium reabsorptive mechanism in the luminal membrane of the cell.

An important feature of the luminal membrane of distal tubule cells is its lower electrical potential difference as compared to that of its peritubular counterpart (34, 43, 44, 45, 79). It is this asymmetrical polarization of the cell (luminal pd less than

³Stationary microperfusion techniques are used to study the steady-state distribution of potassium across the tubular epithelium under conditions approximating zero net fluid movement (46). This is achieved by placing, between separating oil droplets, a small volume of an initially electrolyte-free raffinose solution into a tubule. The concentration of potassium increases progressively until a limiting steady-state concentration difference develops. This makes possible the comparison of ionic concentration gradients with those required for equilibrium at the observed transepithelial electrical potential difference.

peritubular pd) that gives rise to the significant transepithelial electrical potential difference (lumen negative) in the second half of the distal tubule. The depolarization of the luminal potential provides a mechanism favoring movement of potassium from cell to lumen.

An unsolved problem at present is the origin of the luminal potential difference of distal tubule cells. Diffusion potentials have been implicated (43, 46, 79). In particular, sodium ions could lower, by their passive movement from lumen to cell, a potassium diffusion potential oriented in the opposite direction (see Figs. 4 and 5). However, some doubt has arisen as to whether the diffusion permeability of the luminal membrane of the cell is as high as had previously been thought to be the case. In distal tubule cells of *Amphiuma* at least, the electrogenic effects of changing the *luminal* sodium concentration manifest themselves predominantly by changes of the potential difference across the *peritubular* cell membrane, a response thought to be due to stimulation of an electrogenic sodium transport system at this site. This means that the entry of sodium ions across the luminal cell boundary does not carry electrical charge (current) and thus proceeds by some electrically neutral mechanism. Such a mode of transport could be similar to the carrier-mediated mechanism that appears to exist in the luminal membrane of the proximal tubule in *Necturus* (63, 66) and in the outward-facing membrane of the isolated frog skin (7).

It follows from these considerations that sodium ions are unlikely to generate directly the depolarization of the luminal cell membrane. In the rat distal tubule, the chloride permeability is also low; the presence of an active reabsorptive chloride pump is implied by the fact that the transepithelial potential difference is too low to accomplish passive chloride translocation at a rate high enough to account for the observed rates of net transport (43). Accordingly, from our present knowledge of permeabilities and concentration differences, it seems that diffusion potentials are probably not the sole source of the electrical potential differences across the luminal boundary of the cell. Rather, it is more likely that some active, directly electrogenic transport process, located within the luminal cell membrane, contributes directly to the lowering of the electrical potential difference across the luminal membrane. The most likely candidates are chloride and hydrogen ions. For instance, it is tempting to speculate that a reduction along the distal tubule of an electrogenic reabsorptive chloride pump in the luminal membrane of the cell, in the presence of a constant or even increasing luminal potassium permeability, might be involved. This hypothesis assumes that along the early distal tubule, chloride transport across the luminal membrane is electrogenic and contributes significantly to the luminal membrane potential. Reduced activity or a less electrogenic mode of pumping could, conceivably, lower the luminal potential difference progressively along the distal tubule and thus contribute to the steeper transepithelial potential difference across the late distal tubule.

It is relevant to consider within this context the subdivisions of the distal nephron; some important functional parameters are summarized in Fig. 7. It is apparent that several distinct segments with different functional properties exist beyond the loop of Henle. The epithelium of the early portion of the distal tubule is morphologically similar to that of the thick ascending limb of Henle's loop. An outstanding feature is the presence of an active chloride pump (13, 14, 60). Whereas the transepithelial potential difference of the thick ascending limb is positive with respect to the peritubular fluid, the transepithelial potential difference of the early distal tubule is intermediate between this positive potential of the thick ascending limb and the strongly negative potential difference of the late distal tubule (13, 14, 60). As dis-

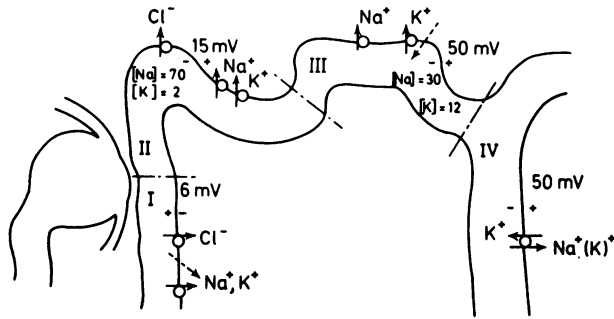

FIG. 7. Subdivisions of the distal nephron. (I) Thick ascending limb of Henle's loop, the site of active chloride reabsorption and an electrical potential difference oriented so as to render the lumen positive. (II) Early part of distal convoluted tubule. Transepithelial potential difference intermediate between that of the thick ascending limb of Henle's loop and the strongly negative potential difference across the late distal tubule. (III) Late part of the distal convoluted tubule; potential difference strongly negative. Main site of tubular potassium secretion, but potassium reabsorption also possible. (IV) Cortical collecting tubule; potential difference strongly negative. Site of active potassium secretion.

Sodium chloride reabsorption and hydrogen ion secretion occur along all divisions of the distal nephron. (From Ref. 82.)

cussed before, the late distal tubule also shares some morphological characteristics with the cortical collecting tubule.

FUNCTIONAL DIFFERENCES BETWEEN THE LATE DISTAL TUBULE AND THE CORTICAL COLLECTING TUBULE

Although the morphology and the electrical potential difference of the late distal tubule and the cortical collecting tubule (about -50 mV , lumen negative) are similar, these segments exhibit at least four significant functional differences: (a) there is present, in the cortical collection tubule, a sodium-sensitive, active potassium pump at the luminal membrane of the cell; (b) the potassium secretory mechanism in the cortical collecting tubule can be shown to be a directly electrogenic process, shifting the luminal potential toward more positive potential values; (c) the time course of attaining steady-state transepithelial concentration differences is rapid in the distal tubule but quite slow in the cortical collecting tubule; and (d) the presence of an active reabsorptive potassium pump has been firmly established at the level of the distal convoluted tubule but not in the cortical collecting tubule. In the following, some of these differences will be considered in some detail.

The presence of an active secretory potassium transport mechanism in the cortical collecting tubule has been established by observing luminal potassium concentrations in excess of those predicted from the measured electrical potential difference (35). In contrast, luminal potassium concentrations in the distal tubule are usually below those predicted from the free-flow and steady-state electrical potential differences (27, 44, 45, 46). Figure 8 depicts the relationship between luminal potassium concentrations and the transepithelial electrical potential differences in distal tubules of the rat and the isolated collecting tubule of rabbits. Inspection of the graph indicates that whereas the potassium concentrations of distal tubular samples clearly fall below those expected from the transepithelial potential difference, the situation is different in cortical collecting tubules. The latter are characterized by their ability to elevate the potassium concentrations, in some instances at least, beyond the levels expected from the electrical potential difference

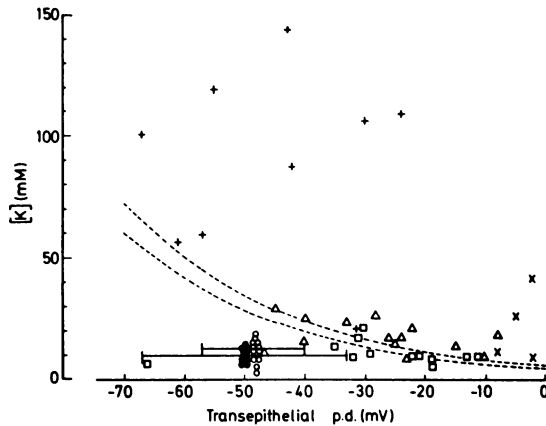

FIG. 8. Relationship between luminal potassium concentration and transepithelial electrical potential in distal tubule of normal rats (\circ , \bullet) and isolated collecting tubule of normal rabbits (\square , Δ , $+$, \times). Broken lines indicate equilibrium K for PD with bath K = 5.0 mequiv/liter (upper) or plasma K = 4.1 mequiv/liter (lower). \circ = data from Ref. 45 under free-flow conditions. \bullet = data from Ref. 46 under stop-flow conditions. \square = data from Ref. 35 contact times 3–28 sec. Δ = data from Ref. 35 contact times 30–47 sec. $+$ = data from Ref. 35 contact times 2.2–22.7 min. \times = data from ref. 35 contact times 2.5–22.5 min. (From Refs. 35 and 82).

and passive distribution. In particular at low flow rates through the cortical collecting tubules (luminal perfusion rate: 0.1 nl min^{-1} , corresponding to contact times in the order of 20 min), the high luminal potassium concentration indicates the presence of an active secretory potassium pump. Accordingly, whereas in the distal tubule the presence of active potassium transport has so far been shown convincingly only in the peritubular cell membrane (see the preceding), such a mechanism has been established in the luminal membrane of the cortical collecting tubule.⁴ That this active potassium pump resides within the luminal cell membrane is highly likely since otherwise unreasonably high cellular potassium activities would be necessary to drive potassium ions passively from cell to the lumen (82). However, final resolution of this problem, i.e., luminal localization of the active potassium transport, must await clarification of the precise electrical potential and chemical activity profile across the collecting tubule epithelium. Such information is presently not available.

Nevertheless, these considerations as well as the direct electrogenic character of potassium secretion (see the following) make it likely that in addition to active peritubular potassium uptake, an additional active transport step should be included at the luminal cell boundary of cortical collecting tubule cells [See Fig. 4 (b)]. Presence of a second active potassium pump would thus constitute one of the main differences between the epithelium of the late distal tubule and that of the cortical collecting duct since active potassium transport is an essential feature of the peritubular membranes of the cells of *both* nephron segments. It is also noteworthy

⁴The fact that active peritubular potassium transport does not manifest itself by transepithelial potassium concentration ratios in excess of those to be expected from the electrical potential difference at the distal tubular level is explained by the presence of active luminal potassium uptake. Apparently, the balance of active secretory (peritubular) and reabsorptive (luminal) mechanisms is poised in favor of reabsorption and results in concentration ratios across the late distal tubular epithelium that are smaller than those predicted from passive distribution despite the fact that peritubular potassium uptake includes an active component.

that the passive potassium conductance of the cortical collecting tubule is much lower than that of the distal tubule (14, 43). This difference is important and may explain the ability of the cortical collecting tubule to sustain and develop the high transepithelial potassium concentration differences found in the final urine.

In passing it should be realized that in view of the presence of active potassium uptake across the peritubular cell membranes, it is quite incorrect to consider potassium secretion in the distal tubule to be a passive consequence of the electrical potential gradient. This neglects the importance of active potassium transfer across both the peritubular and luminal cell membranes in determining the rate of transepithelial potassium movement. Potassium transport in the distal tubule is passive only to the extent that potassium transfer across the *luminal* cell membrane may not necessitate an active transport step since the electrochemical potential gradient could be adequate to drive potassium ions passively across this cell membrane. Clearly, however, such movement "down" an electrochemical potential gradient *per se* does not exclude interaction of potassium ions with the cell membrane. Such interaction may take the form of some carrier-mediated translocations such as facilitated diffusion, exchange diffusion, or active transport, the latter being a process that would extrude potassium from cell to lumen at a rate higher than that to be expected from the electrical and chemical driving forces. These processes could take place *in addition* to passive potassium leakage across the luminal membrane of the cell. The recent observations of rather low potassium activities in the cell (37) and the finding that lowering of the transepithelial electrical potential difference in the immediate proximity of the collecting pipette does not affect the potassium concentration of the collected fluid sample (83) make the presence of such additional transfer mechanisms a possibility to be explored further.

One difficulty in determining the contribution of passive potassium transfer to secretion in both distal tubule and collecting duct is the lack of information concerning the effects on potassium transport of changes in the transepithelial potential difference *per se*. In most instances in which a fall of the transtubular electrical potential difference was found to be associated with a decline in potassium secretion, the electrical potential change was induced by reduction of the sodium concentration in the lumen (32, 35, 43, 79). But the latter change *per se* could affect potassium transport, either by changing the electrical polarization of the cell, thus modulating passive potassium entry across the peritubular membrane, or by directly affecting carrier-mediated sodium-potassium exchange across the luminal or peritubular cell membranes or both. There has been a tendency to interpret changes of potassium transport after such manipulations in the distal tubule as being due primarily to changes in the electrical driving force. In contrast, in the collecting duct changes in potassium transport after sodium-mediated changes in the electrical potential difference have been thought to result specifically from the lack of sodium ions. A critical assessment, however, of the effects of *electrical* voltage clamping, at constant luminal sodium concentrations, of the distal tubule and the collecting duct would be necessary to resolve this problem and to ascertain the precise effect of changes of the electrical potential difference *per se* upon the movement of potassium across these two segments. Nevertheless, since the permeability of the distal tubule to potassium is quite high (43) and that of the cortical collecting tubule appreciably lower (14), it is to be expected that potassium movement will be more affected by electrical potential changes across the late distal tubule than across the cortical collecting tubule.

A second point of interest concerns the direct electrogenicity of the potassium transport system in the distal tubule and the collecting tubule. Recent studies on the isolated cortical collecting tubule have clearly shown that the secretion of both hydrogen and potassium ions generates an electrical potential difference (9, 64). Thus, the lumen of the collecting tubule, normally rendered electrically negative by active sodium reabsorption, is made more negative if either hydrogen ion secretion is reduced by Diamox (64) or potassium secretion is lowered by acidification of the luminal perfusate (9). The interpretation of these voltage changes is that a positive voltage is caused by active hydrogen or potassium secretion into the lumen and that this can modify the transepithelial voltage difference. Thus, assuming a K-Na exchange ratio of the luminal pump to be greater than unity, active potassium secretion carries electrical charge in a direction opposite to that of sodium and lowers the negative potential generated by active sodium reabsorption. Suppression of the pumping rate of the K-Na transport mechanism renders the lumen electrically more negative since the transepithelial potential difference built up by active sodium transport is now unopposed. Hence, under these conditions, increased negativity of the collecting duct lumen is associated with diminished net potassium secretion. In general, just the opposite situation holds for the distal tubular epithelium, in which an increase in luminal negativity is usually associated with enhanced potassium secretion. Only one observation suggests the possibility that electrogenic potassium secretion may also play a role in the late distal tubule. Wright has observed that the transepithelial potential becomes more negative when rats are fed a potassium-rich diet for several weeks (81). This potential difference is reduced upon infusion of potassium salts. The larger potential difference across the luminal membrane of the cells (lumen positive to cell interior) could be due to enhanced electrogenic potassium secretion into the distal tubular lumen subsequent to stimulation of distal tubular potassium secretion in potassium adapted animals (84).

The distal tubule and the cortical collecting tubule also differ sharply with respect to the rate at which luminal steady-state concentration differences are established. In the distal tubule, steady-state concentration differences are established rapidly. Thus, the luminal steady-state concentration of potassium, at each site along the distal convolution, is virtually identical to its normal free-flow value (44, 45, 46). Importantly a dramatic increase in distal tubular flow rate by a factor of 10 does not materially affect this relationship, provided potassium intake has been adequate (39). This very rapid approach to the steady state (within seconds) (K. Hierholzer, F. S. Wright, and G. Giebsich, unpublished observations) means that tubular secretion of potassium is dramatically affected by flow rate along the distal tubule. It is certain that this marked flow sensitivity of distal tubular potassium transport is the main mechanism by which diuretics promote urinary potassium loss (22, 27). Thus, following administration of diuretics, acting at a nephron site upstream of the distal tubule, this nephron segment receives a powerful stimulus for potassium secretion. As the concentration of potassium remains constant with increasing volume flow, secretion rate varies directly and proportionately with flow rate. Thus, most diuretics—with the exception of ouabain (22, 65) and carbonic anhydrase inhibitors (44) which both increase the luminal potassium concentration—act to promote urinary potassium loss by the delivery of larger than normal fluid loads to the distal tubule and not by changing the transepithelial potassium concentration difference. This mechanism may also be involved after interventions that reduce proximal tubular sodium reabsorption such as extracellular volume expansion (10, 17, 38, 39, 41),

contralateral nephrectomy (30), etc. Similarly, it has been pointed out that changes in distal sodium delivery and reabsorption affect the sequence of events with respect to distal tubular potassium transport in acid-base disturbances (42). Thus, metabolic acidosis initially reduces distal tubular potassium secretion, but this potassium-sparing effect is subsequently overridden by enhanced sodium delivery into the distal tubule where it affects potassium secretion probably by augmentation of flow rate (20, 25, 42).

Two mechanisms may account for the flow-sensitivity of distal tubular potassium secretion. First, peritubular potassium uptake may be stimulated by a lowering of the concentration difference against which potassium uptake normally occurs. This assumes that the cellular potassium concentration might be moderately reduced due to the significant egress of cellular potassium into the lumen as a result of increased luminal flow rate. A second link between flow rate in the distal tubule and potassium secretion may be electrical. It has been shown on the one hand that the luminal sodium concentration rises with increasing distal tubular flow rate (38, 41) and on the other that the sodium concentration in the lumen regulates the electrical potential difference across the peritubular cell membrane in such a way that cell negativity increases with elevation of luminal sodium concentration (77). Thus, flow-induced increments of luminal sodium concentration could stimulate uptake of potassium into cells by increasing the electrical driving force that transfers this ion from peritubular fluid into the cell.

Quite different from the behavior of the distal tubule in this respect is that of the cortical collecting tubule. In this nephron segment, as the contact time between the luminal fluid and epithelium is prolonged, the concentration of potassium increases dramatically (35). Usually, contact times had to exceed 50 sec for luminal potassium concentrations to reach levels that reveal active secretion. Hence, changes in flow rate will greatly affect net secretion in the distal tubule but less so or not at all in the cortical collecting tubule. It is presently unclear what factors are responsible for this difference in the functional behavior of the two nephron segments. One might speculate that either the capacity of the collecting duct potassium pump is inherently limited by a low turnover rate or the luminal potassium permeability of the distal tubule, which greatly exceeds that of the collecting tubule, favors rapid equilibration of potassium across the luminal membrane.

Finally, the distal tubule of the rat has the capacity of net potassium reabsorption (22, 24), whereas such potassium reabsorption has not been established in the cortical collecting tubule (14). It is likely that the reversal of the direction of net transport of potassium in the distal tubule is a consequence primarily of diminished peritubular potassium uptake. In kinetic studies of potassium transport in potassium-deprived rats, it can be shown that the transport pool of distal tubule cells falls sharply (19) and that cellular potassium activity declines (37). It is proposed that as a consequence of these changes, net secretion of potassium either ceases or even is changed to net potassium reabsorption as the influx of potassium from cell to lumen drops, leaving unopposed active potassium uptake from lumen to cell.

As in the distal tubule, the collecting duct epithelium is also able to effect net reabsorption of potassium. Particularly in conditions of dietary potassium and sodium deprivation, it can be shown that net reabsorption of potassium occurs beyond the distal tubule (21, 44, 45). Frequently, even under conditions of a normal potassium and sodium intake and particularly at low urine flow rates, it can be shown that the fractional excretion rate of potassium in the final urine is significantly less

than that at the end of distal tubules at the kidney surface (29). Puncture of single collecting tubules in the rat has confirmed the presence of net reabsorption at this terminal nephron segment (21). It is virtually certain that this process of potassium reabsorption is active in nature.

ACKNOWLEDGMENT

I am indebted to Dr. F. S. Wright for stimulating discussion of various aspects of this paper.

REFERENCES

1. Bank, N., and Aynedjian, H. S. A micropuncture study of potassium excretion by the remnant kidney. *J. Clin. Invest.* **52**, 1480-1490 (1973).
2. Berliner, R. W. Renal mechanism for potassium excretion. *Harvey Lect.* **55**, 141-171 (1961).
3. Berliner, R. W., and Kennedy, T. J., Jr. Renal tubular secretion of potassium in the dog. *Proc. Soc. Exp. Biol. Med.* **67**, 542-545 (1948).
4. Berliner, R. W., Kennedy, T. J., Jr., and Hilton, J. G. Renal mechanisms for excretion of potassium. *Amer. J. Physiol.* **162**, 348-367 (1950).
5. Berliner, R. W., Kennedy, T. J., Jr., and Orloff, J. Relationship between acidification of the urine and potassium metabolism. *Amer. J. Med.* **11**, 274-282 (1951).
6. Berliner, R. W., Kennedy, J. T., Jr., and Orloff, J. Factors affecting the transport of potassium and hydrogen ions by the renal tubule. *Arch. Int. Pharmacodyn. Ther.* **97**, 299-312 (1954).
7. Biber, T. U. L., and Curran, P. F. Direct measurement of uptake of sodium at the outer surface of the frog skin. *J. Gen. Physiol.* **56**, 83-99 (1970).
8. Black, D. A. K., Davies, H. E. F., Emery, E. W., and Wade, E. G. Renal handling of radioactive potassium in man. *Clin. Sci.* **15**, 277-283 (1956).
9. Boudry, J. F., Stoner, L. C., and Burg, M. B. The effect of lumen pH on potassium transport in renal cortical collecting tubules. *Amer. J. Physiol.* (in press).
10. Brenner, B. M., and Berliner, R. W. Relationship between extracellular volume and fluid reabsorption by the rat kidney. *Amer. J. Physiol.* **217**, 6-12 (1969).
11. Brenner, B. M., and Berliner, R. W. Transport of potassium. In "Handbook of Physiology" (J. Orloff and R. W. Berliner, Eds.) Sect. 8, pp. 497-520. American Physiological Society, Washington, D. C., 1973.
12. Burg, M. B., Grantham, J. J., Abramov, M., and Orloff, J. Preparation and study of fragments of single rabbit nephrons. *Amer. J. Physiol.* **210**, 1293-1298 (1966).
13. Burg, M. B., and Green, N. Function of the thick ascending limb of Henle's loop. *Amer. J. Physiol.* **224**, 659-668 (1973).
14. Burg, M., and Stoner, L. Sodium transport in the distal nephron. *Fed. Proc.* **33**, 31-36 (1974).
15. Burg, M., Stoner, L., Cardinal, J., and Green, N. Furosemide effect on isolated perfused tubules. *Amer. J. Physiol.* **225**, 119-124 (1973).
16. Clapp, J. R., and Robinson, R. R. Osmolality of distal tubular fluid in the dog. *J. Clin. Invest.* **45**, 1847-1853 (1966).
17. Cortney, M. A., Mylle, M., Lassiter, W. E., and Gottschalk, C. W. Renal tubular transport of water, solute and PAH in rats loaded with isotonic saline. *Amer. J. Physiol.* **209**, 1199-1205 (1965).
18. Davidson, D. G., Levinsky, N. G., and Berliner, R. W. Maintenance of potassium excretion despite reduction of glomerular filtration during sodium diuresis. *J. Clin. Invest.* **37**, 548-555 (1958).
19. De Mello-Aires, M., Giebisch, G., Malnic, G., and Curran, P. F. Kinetics of potassium transport across single distal tubules of rat kidney. *J. Physiol. (London)* **232**, 47-70 (1973).
20. DeSousa, R. C., Harrington, T. J., Ricanati, E. S., Shelkrot, J. W., and Schwartz, W. B. Renal regulation of acid-base equilibrium during chronic administration of mineral acid. *J. Clin. Invest.* **53**, 465-476 (1974).
21. Diezi, J., Michoud, P., Aceves, J., and Giebisch, G. Micropuncture study of electrolyte transport across papillary collecting duct of the rat. *Amer. J. Physiol.* **224**, 623-634 (1973).
22. Duarte, C. G., Chométy, F., and Giebisch, G. Effect of amiloride, ouabain, and furosemide on distal tubular function in the rat. *Amer. J. Physiol.* **221**, 632-639 (1971).
23. Evanson, R. L., Lockhart, E. A., and Dirks, J. H. Effect of mercurial diuretics on tubular sodium and potassium transport in the dog. *Amer. J. Physiol.* **222**, 282-289 (1972).
24. Finkelstein, F. O., and Hayslett, J. P. Role of medullary structures in the functional adaptation of renal insufficiency. *Kidney Int.* **6**, 419-425 (1974).

25. Gennari, F. J., and Cohen, J. J. The role of the kidney in potassium homeostasis: Lessons from acid-base disturbances. *Kidney Int.* **8**, 1-5 (1975).
26. Giebisch, G. Electrical potential measurements on single nephrons of *Necturus*. *J. Cell. Comp. Physiol.* **51**, 221-239 (1958).
27. Giebisch, G. Renal potassium excretion. In "The Kidney, Morphology, Biochemistry, Physiology" (C. Rouiller and A. Muller, Eds.), Vol. 3, pp. 329-382. Academic Press, Inc., New York and London, 1971.
28. Giebisch, G. The effects of drugs on the electrophysiological properties of kidney tubules. In "Drugs and Transport Processes" (E. Callingham, Ed.), pp. 3-22. University Park Press, Baltimore, London, Tokyo, 1974.
29. Giebisch, G. Some recent developments in renal electrolyte transport. In "Recent Advances in Renal Physiology and Pharmacology" (L. Wesson and G. M. Fanelli, Eds.), pp. 125-148. University Park Press, Baltimore, London, Tokyo, 1974.
30. Giebisch, G., Diezi, J., Michoud, P., and Grandchamp, A. The effect of chronic reduction of GFR on tubular sodium and potassium transport in control and contralaterally nephrectomized rats. In "International Symposium on Renal Handling of Sodium" (H. Wirz and F. Spinelli, Eds.), pp. 89-94. S. Karger, Basel, 1972.
31. Giebisch, G., and Malnic, G. Coupled ion movement across the renal tubule. In "Transport Mechanisms in Epithelia" (H. H. Ussing and N. A. Thorn, Eds.), Alfred Benzon Symposium, pp. 537-552. Munksgaard, Copenhagen, 1973.
32. Giebisch, G., Malnic, G., Klose, R. M., and Windhager, E. E. Effect of ionic substitutions on distal potential differences in rat kidney. *Amer. J. Physiol.* **211**, 560-568 (1966).
33. Giebisch, G., Sullivan L. P., and Whittetbury, G. Relationship between tubular net sodium reabsorption and peritubular potassium uptake in the perfused *Necturus* kidney. *J. Physiol.* **230**, 51-74 (1973).
34. Giebisch, G., and Windhager, E. E. Electrolyte transport across renal tubular membranes. In "Handbook of Physiology (J. Orloff and R. W. Berliner, Eds.), Sect. 8, pp. 315-376. American Physiological Society, Washington D.C., 1973.
35. Grantham, J. J., Burg, M. B., and Orloff, J. The nature of transtubular Na and K transport in isolated rabbit renal collecting tubules. *J. Clin. Invest.* **49**, 1815-1826 (1970).
36. Keith, N. M., Osterberg, A. E., and King, H. E. The excretion of potassium by the normal and diseased kidney. *Ass. Amer. Phys.* **55**, 219-222 (1940).
37. Khuri, R. N., Agulian, S. K., and Kalloghlian, A. Intracellular potassium in cells of the distal tubule. *Pflueger's Arch.* **335**, 297-307 (1972).
38. Khuri, R. N., Wiederholt, M., Strieder, N., and Giebisch, G. The effects of graded solute diuresis on renal tubular sodium transport in the rat. *Amer. J. Physiol.* **228**, 1262-1268 (1975).
39. Khuri, R. N., Wiederholt, M., Strieder, N., and Giebisch, G. The effects of flow rate and potassium intake on distal tubular potassium transfer. *Amer. J. Physiol.* **228**, 1249-1261 (1975).
40. Kunau, R. T., Jr., Webb, H. L., and Borman, S. C. Characteristics of the relationship between the flow rate of tubular fluid and potassium transport in the distal tubule of the rat. *J. Clin. Invest.* **54**, 1488-1495 (1974).
41. Landwehr, D. M., Klose, R. M., and Giebisch, G. Renal tubular sodium and water reabsorption in the isotonic sodium chloride loaded rat. *Amer. J. Physiol.* **212**, 1327-1333 (1967).
42. Malnic, G., de Mello-Aires, M., and Giebisch, G. Potassium transport across renal distal tubules during acid-base disturbances. *Amer. J. Physiol.* **221**, 1192-1208 (1971).
43. Malnic, G., and Giebisch, G. Some electrical properties of distal tubular epithelium in the rat. *Amer. J. Physiol.* **223**, 797-808 (1972).
44. Malnic, G., Klose, R. M., and Giebisch, G. Micropuncture study of renal potassium excretion in the rat. *Amer. J. Physiol.* **206**, 647-686 (1964).
45. Malnic, G., Klose, R. M., and Giebisch, G. Micropuncture study of distal tubular potassium and sodium transport in rat nephron. *Amer. J. Physiol.* **211**, 529-547 (1966).
46. Malnic, G., Klose, R. M., and Giebisch, G. Microperfusion study of distal tubular potassium and sodium transfer in rat kidney. *Amer. J. Physiol.* **211**, 548-559 (1966).
47. Malvin, R. L., Wilde, W. S., and Sullivan, L. P. Localization of nephron transport by stop-flow analysis. *Amer. J. Physiol.* **194**, 135-142 (1958).
48. McCance, R. A., and Widdowson, E. M. Alkalosis with distorted kidney function. *Lancet* **2**, 247-249 (1937).
49. Morel, F. Les modalités de l'excretion du potassium par la rein: Etude experimentale à l'aide du radio-potassium chez le lapin. *Helv. Physiol. Pharmacol. Acta* **13**, 276-294 (1955).

50. Morgan, T., Tadakoro, M., Margin, D., and Berliner, R. W. Effect of furosemide on Na⁺ and K⁺ transport studied by microperfusion of the rat nephron. *Amer. J. Physiol.* **218**, 292–297 (1970).
51. Mudge, G. H., Foulks, J., and Gilman, A. The renal excretion of potassium. *Proc. Soc. Exp. Biol. Med.* **67**, 545–547 (1948).
52. Mudge, G. H., Ames, A., Foulks, J., and Gilman, A. Effects of drugs on renal secretion of potassium in the dog. *Amer. J. Physiol.* **161**, 151–158 (1950).
53. Mudge, G. H., Foulks, J., and Gilman, G. Renal secretion of potassium in the dog during cellular dehydration. *Amer. J. Physiol.* **161**, 159–166 (1950).
54. Peterson, L. M. N. The effect of sodium intake on renal potassium excretion. Thesis, Yale University School of Medicine (1975).
55. Pitts, R. F., Gurd, R. S., Kessler, R. H., and Hierholzer, K. Localization of acidification of urine, potassium and ammonia secretion and phosphate reabsorption in the nephron of the dog. *Amer. J. Physiol.* **194**, 125–134 (1958).
56. Proverbio, F., and Whittembury, G. Cell electrical potentials during enhanced sodium extrusion in guinea pig kidney cortex slices. *J. Physiol.* (in press).
57. Rector, F. C., Jr. Acidification of the urine. In "Handbook of Physiology" (J. Orloff and R. W. Berliner, Eds.), Sec. 8, pp. 431–454. American Physiol. Soc., Washington, D.C., 1973.
58. Richet, G., Haegge, J., and Gaha, M. Corrélation entre les transferts de bicarbonate et la morphologie du nephron chez le rat. *Nephron* **7**, 413–429 (1970).
59. Richet, G., Haegge, J., and Gaha, M. Effet de l'acidose gazeuse sur les parties distales du nephron du rat albinos. *C. R. Acad. Sci. Paris, Ser. D* **269**, 1538–1542 (1969).
60. Rocha, A. S., and Kokko, J. P. Sodium chloride and water transport in the medullary thick ascending limb of Henle. Evidence for active chloride transport. *J. Clin. Invest.* **52**, 612–623 (1973).
61. Schultze, R. G. Recent advances in the physiology and pathophysiology of potassium excretion. *Arch. Intern. Med.* **113**, 885–897 (1973).
62. Silva, P., Hayslett, J. P., and Epstein, F. H. Chronic K adaptation: Role of Na-K ATPase. *J. Clin. Invest.* **52**, 2665–2671 (1973).
63. Spring, K. R., and Giebisch, G. Efficiency of Na transport in Necturus proximal tubule. *Kidney Int.* **6**, 100A (1974).
64. Stoner, L. C., Burg, M. B., and Orloff, J. Ion transport in cortical collecting tubule: Effect of amiloride. *Amer. J. Physiol.* **227**, 453–459 (1974).
65. Strieder, N., Khuri, R. N., Wiederholt, M., and Giebisch, G. Studies on the renal action of ouabain in the rat. Effects in the non-diuretic state. *Pfluegers Arch.* **349**, 91–107 (1974).
66. Stroup, R. F., Weinman, E., Hayslett, J. P., and Kashgarian, M. Effect of luminal permeability on net transport across the amphibian proximal tubule. *Amer. J. Physiol.* **226**, 1110–1117 (1974).
67. Sullivan, L. P. Effect of sodium and impermeant anions on renal K transport during stopped flow. *Amer. J. Physiol.* **201**, 774–780 (1961).
68. Sullivan, W. J. Electrical potential differences across distal renal tubules of Amphiuma. *Amer. J. Physiol.* **214**, 1096–1163 (1968).
69. Tadokoro, M., and Boulpaep, E. L. Electrophoretic method of ion injection in single kidney cells. *Yale J. Biol. Med.* **45**, 432–435 (1972).
70. Thoenes, W., and Langer, K. H. Relationship between cell structures of renal tubules and transport mechanisms. In "Renal Transport and Diuretics" (K. Thureau and H. Jahrmärker, Eds.), pp. 37–49. Springer-Verlag, New York, 1969.
71. Thompson, D. D., and Pitts, R. F. Effects of alterations of renal arterial pressure on sodium and water excretion. *Amer. J. Physiol.* **168**, 490–499 (1952).
72. Vander, A. J. Potassium secretion and reabsorption in distal nephron. *Amer. J. Physiol.* **201**, 505–510 (1961).
73. Walker, W. G., Cooke, C. R., Payne, J. W., Baker, C. R. F., and Andrew, D. J. Mechanism of renal potassium secretion studied by a modified stop-flow technique. *Amer. J. Physiol.* **200**, 1133–1138 (1961).
74. Whittembury, G. Relationship between sodium extrusion and electrical potentials in kidney cells. In "Electrophysiology of Epithelial Cells" (G. Giebisch, Ed.), pp. 153–178. F. K. Schattauer Verlag, Stuttgart and New York, 1971.
75. Wiederholt, M., Agulian, S., and Khuri, R. N. Intracellular potassium in the distal tubule of the adrenalectomized and aldosterone treated rat. *Pfluegers Arch.* **347**, 117–123 (1974).
76. Wiederholt, M., Schoormans, W., Fischer, F., and Behn, C. Mechanism of action of aldosterone on potassium transfer in the rat kidney. *Pfluegers Arch.* **345**, 157–178 (1973).

77. Wiederholt, M., and Giebisch, G. Some electrophysiological properties of the distal tubule of *Amphiuma* kidney. *Fed. Proc.* **33**, 387 (1974).
78. Wiederholt, M., Sullivan, W. J., Giebisch, G., Solomon, A. K., and Curran, P. F. Transport of potassium and sodium across single distal tubules of *Amphiuma*. *J. Gen. Physiol.* **57**, 495-529 (1971).
79. Woodhall, P. B., and Tisher, C. C. Response of the distal tubule and cortical collecting duct to vasopressin in the rat. *J. Clin. Invest.* **52**, 3095-3108 (1973).
80. Wright, F. S. Increasing magnitude of electrical potential along the renal distal tubule. *Amer. J. Physiol.* **220**, 624-638 (1971).
81. Wright, F. S. Alterations in electrical potential and ionic conductance of renal distal tubule cells in potassium adaptation. *Proc. Int. Union Physiol. Sci.* **IX**, 609 (1971).
82. Wright, F. S. Potassium transport by the renal tubule. In "MTP International Review of Science" (K. Thirau, Ed.), Series I, Vol. 6, pp. 79-106. Butterworth & Co., London and Washington, D.C., 1974.
83. Wright, F. S. Relation of electrical potential difference to potassium secretion by the distal renal tubule. *Int. Congr. Physiol. Sci. Proc. 26th*, **XI**, 115 (1974).
84. Wright, F. S., Strieder, N., Fowler, H. B., and Giebisch, G. Potassium secretion by the distal tubule after potassium adaptation. *Amer. J. Physiol.* **221**, 437-448 (1971).