

## ORIGINAL ARTICLE

# Design, construction and validation of a nose-only inhalation exposure system to measure infectivity of filtered bioaerosols in mice

B.R. Stone<sup>1,2</sup>, B.K. Heimbuch<sup>1</sup>, C.-Y. Wu<sup>2</sup> and J.D. Wander<sup>3</sup><sup>1</sup> Applied Research Associates, Panama City, FL USA<sup>2</sup> Department of Environmental Engineering Sciences, University of Florida, Gainesville, FL USA<sup>3</sup> Airbase Sciences Branch, Air Force Research Laboratory, Tyndall AFB, FL USA**Keywords**

antimicrobials, infection, polymerase chain reaction, viruses.

**Correspondence**

Joseph D. Wander, Air Force Research Laboratory, 139 Barnes Drive, Suite 2, Tyndall AFB, FL 32403, USA. E-mail: Joe.wander@tyndall.af.mil

2012/0335: received 22 February 2012, revised 14 May 2012 and accepted 16 May 2012

doi:10.1111/j.1365-2672.2012.05403.x

**Abstract****Aims:** The aim of this project was to validate a method to deliver a reproducible, selected dose of infective bioaerosol through a respiratory protective technology to an animal that exhibits a proportional clinical response.**Methods and Results:** The Controlled Aerosol Test System (CATS) was designed to generate and condition a viable infective aerosol, pass it through a treatment technology and thence to the breathing zone of a mouse constrained in a Nose-Only Inhalation Exposure System (NOIES). A scanning mobility particle sizer and impingers at sampling ports were used to show that viability is preserved and particle size distribution (PSD) is acceptably uniform throughout the open CATS, including the 12 ports of the NOIES, and that a particle filter used caused the expected attenuation of particle counts.**Conclusions:** Controlled Aerosol Test System delivers uniformly to mice constrained in the NOIES a selectable dose of viral bioaerosol whose PSD and viable counts remain consistent for an hour.**Significance and Impact of the Study:** This study's characterization of CATS provides a new test system in which a susceptible small-animal model can be used as the detector in a quantitative method to evaluate the ability of respiratory protective technologies to attenuate the infectivity of an inspired pathogenic aerosol. This provides a major improvement over the use of viable bioaerosol collectors (e.g. impactors and impingers), which provide data that are difficult to relate to the attenuation of pathogenicity.**Introduction**

Bioaerosols are known to be a transmission mechanism for many disease-causing organisms, including *Legionella*, smallpox, severe acute respiratory syndrome (SARS) coronaviruses and rhinovirus (Fiegel *et al.* 2006). However, the role of bioaerosols as an important natural transmission mechanism for influenza is actively debated (Tellier 2006, 2007a,b; Brankston *et al.* 2007; Gardam and Lemieux 2007; Lee 2007; Lemieux *et al.* 2007; Tang and Li 2007). One approach proposed to reduce the risk of infection by pathogenic bioaerosols, particularly to healthcare workers and first responders, is to incorporate

an antimicrobial agent into the air filters of respiratory protection devices. Common antimicrobials can be applied to the surfaces of filtering facepiece respirators (FFRs), including quaternary ammonium compounds (Price *et al.* 1993), *N*-halamines and silver (Foarde *et al.* 2000; Verdenelli *et al.* 2003; Cecchini *et al.* 2004; Sullivan 2006), but these are expected to act only on captured particles to suppress contact transfer.

Taylor *et al.* (1970) and Marchin and Fina (1989) showed the antimicrobial resin poly(styrene-4-[trimethylammonium]methyl triiodide) (PSTI) to be an effective, broad-spectrum disinfectant in aqueous environments. A patent (Messier 2000) has been issued for the use of PSTI

as a constituent at the fibre surface of air filtration media, and *in vitro* studies have reported a 2-log (99%) increase in viable removal efficiency (VRE) after passage through air purification media incorporating PSTI compared to standard filtration systems (Heimbuch *et al.* 2004; Heimbuch and Wander 2006; Lee and Wu 2006; Lee *et al.* 2009). However, one PSTI-coated material rated as an N95 medium performed mechanically as an N99 filter (Stone 2010, pp. 54), which obscured the role of PSTI in the measured VRE.

Ratnesar-Shumate *et al.* (2008) proposed that the water-based mechanism proposed by Taylor *et al.* – capture of I<sub>2</sub> from the surface of the I<sub>3</sub><sup>-</sup> complex during collisions with passing microbes – can be extended to describe a short, through-space capture process from treated fibres, induced by near collisions with bioaerosols as they penetrate an air filter medium. However, the *in vitro* assay they used includes a transfer step in water – which can interact indiscriminately with either background I<sub>2</sub> or I<sub>2</sub> captured by passing micro-organisms to provide a fast mechanism of devitalization. Lee *et al.* (2009) and Rengasamy *et al.* (2010) showed that water vapour has a role in the disinfection mechanism, and numerous examples have been reported in which proteins react competitively to consume I<sub>2</sub> (McFarlane 1956; Eninger *et al.* 2008; Lee *et al.* 2009) by several mechanisms. Quenching experiments collecting filtered bioaerosols in solutions containing thiosulfate or bovine serum albumin showed the process of devitalization by captured I<sub>2</sub> in air to be relatively slow (Lee *et al.* 2009) and possibly unimportant on the time scale of inspiration behind an FFR. Thus, if protection is to be improved significantly by passing exposure to PSTI during filtration, the protective process must occur at the point of contact with the respiratory mucosal surface (an aqueous medium containing potentially interfering proteins), which can be tested only by controlled, quantitative exposure experiments using an animal model.

Experimental inhalation exposure systems are an established tool and the subject of several reviews (Drew and Laskin 1973; MacFarland 1983; Cheng and Moss 1995; Jaeger *et al.* 2006; Wong 2007). Unrelated studies have demonstrated reduced rates of infection by adding filters to livestock housing (Hopkins and Drury 1971; Burmesster and Witter 1972; Dee *et al.* 2005, 2006a,b). However, the inhalation studies did not include filters and the animal studies examined only casual transmission between animals and did not expose the animals to a metered challenge of aerosol in a controlled design. Controlled delivery of graduated doses of infective aerosols through reactive and inert filters is a novel approach to measure the clinical significance of respiratory protection devices. Development and characterization of the delivery system

described below is the necessary enabling step to realize this capability.

## Materials and methods

### System description

The aerosol delivery system, called the Controlled Aerosol Test System (CATS) and illustrated in Fig. 1, was designed and built in house, using both commercial and fabricated components. By design, the CATS enables experiments measuring infection rates of homogeneous (same strain, age, weight and sex) groups of a common laboratory mouse to discriminate the extent, if any, to which a reactive air filter medium diminishes the exposure risk from an aerosolized pathogen challenge compared to the same challenge delivered through a mechanically equivalent, inert medium. The CATS generates a biological aerosol at a range of constant concentrations, passes the aerosol through a filter and delivers the penetrating particles to the nose of a mouse model of human respiration. An earlier version of the CATS is described by Stone (2010).

Tubing used to connect components containing aerosol flows is ½-inch stainless steel. All curves in the tubing containing the main aerosol flow are gradual and smooth, with an inner curvature radius greater than an inch. All valves carrying aerosol flow are ½-inch stainless-steel ball valves. Flows of make-up and purge air are controlled by ¼-inch needle valves followed by rotameters to verify the flow rate. To contain the aerosol challenge, the CATS fits inside a SterilGARD III Advanced Animal Transfer Station (SG603-ATS; Baker Company, Sanford, ME, USA), which has interior dimensions of 27 inches H × 20 inches D × 68 inches W.

### Aerosol generation

In the CATS, air is supplied to the system by an air compressor. For this work, the laboratory air line was filtered first through an oil trap and then a DFC-21 HEPA canister particle trap (Porous Media Corp., St Paul, MN, USA) to feed the nebulizer and porous tube diluters. The animal studies require a source of breathable air free of both particles and toxic gases and vapours, to be provided onsite. If needed, a porous tube humidifier (PermaPure LLC, Toms River, NJ, USA; model MH-070), which contains a Nafion<sup>®</sup> membrane tube, can be used to adjust humidity of the air at this stage.

The airflow then enters a manifold. Part of the air is regulated to 30 psig and flowed into the system as make-up air as required. The rest of the flow is regulated to 25–30 psig and flowed to a Collison nebulizer (BGI Inc.,

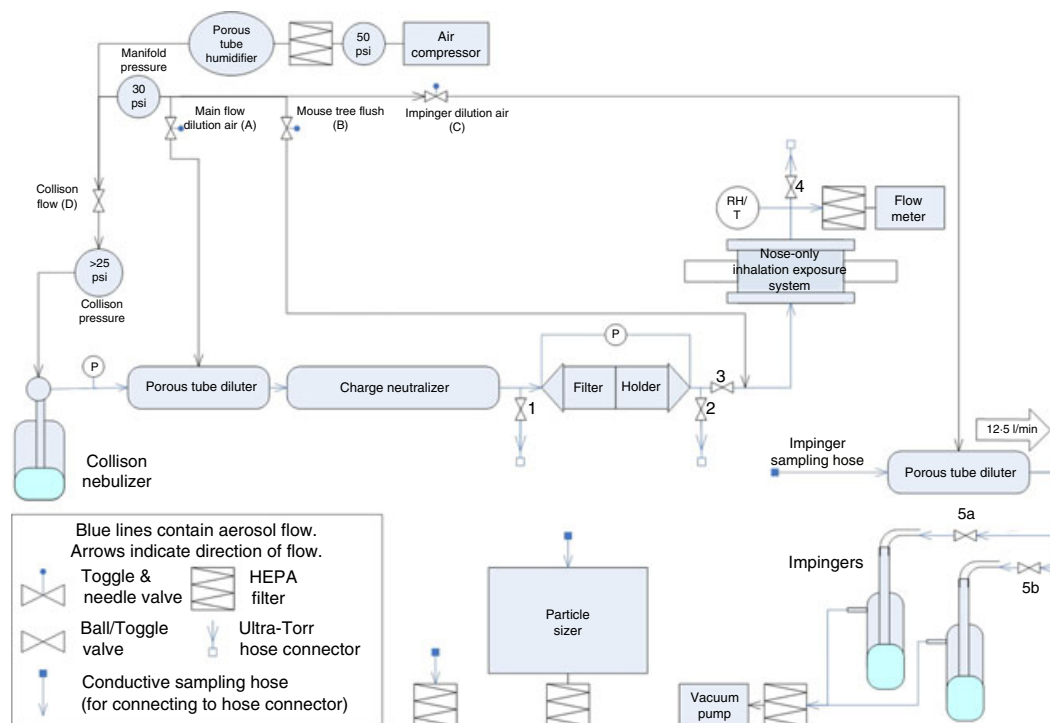

**Figure 1** Process-flow diagram of Controlled Aerosol Test System. The porous tube diluter may be replaced with a diffusion dryer, or the diffusion dryer may be inserted after the porous tube diluter.

Waltham, MA, USA), which generates the bioaerosol. The system is limited by flow capacity to a single-jet Collison nebulizer. A pressure gauge (Dwyer Instruments, Houston, TX, USA; Magnehelic series 2000) tees off directly after the nebulizer. A porous tube diluter (Mott Corp., Farmington, CT, USA; model no. 7610105-020) can be used to deliver make-up air through Valve A (Fig. 1) and to adjust the flow rate after the nebulizer. A diffusion dryer (Air Techniques International, Owings Mill, MD, USA; Model 250) may also be used to dry the droplets down to condensation nuclei. In this validation, only the porous tube diluter was used. It was found during later tests that, at low flow rates, not using the diffusion dryer causes the filters to become wet, distorting particle removal efficiency (PRE) and increasing pressure drop ( $\Delta p$ ).

A 370-MBq  $^{85}\text{Kr}$  beta-emitting charge neutralizer (model no. 3012A; TSI Inc., Shoreview, MN, USA) normalizes the electrical charge put on the particles by the nebulization process. A length of tubing guides the flow to an intersection at which the first sampling guides the flow to an intersection at which the first sampling point in the system, Valve and Port 1, tees off and can be connected via  $\frac{1}{2}$ -inch conductive silicone tubing (TSI; part no. 3001789) to sampling instrumentation. The output from the aerosol generation section can be sampled here. O-Ring compression fittings (Ultra-Torr hose connectors, Swagelok, Solon,

OH, USA) used at the sampling ports allow the operator to easily connect and disconnect instrumentation.

#### Filter holder

The straight arm of the tee enters a custom-built sample holder (Triosyn Corp, Williston, VT, USA) comprising milled inner and outer sleeves that hold a disc of filter medium compressed (by bolts around the edges) between elastomeric annular seals. The sleeve has a tapered chamber 10 cm long before the filter to allow the aerosol to spread and then a tapered chamber 10 cm long after the filter to return to the tubing. The holder can hold circular filters 47 mm in diameter, and smaller discs can be accommodated with the use of reducers.

A second sampling point tees off immediately downstream of the sample holder to Valve and Port 2, which are used to measure the aerosol passing through the filter holder. A differential pressure gauge (Dwyer, Magnehelic series 2000) is connected before and after the sample holder to measure  $\Delta p$  across the filter. Valve 3, following the tee for Valve 2, is necessary to divert the aerosol flow from the animal subjects during postexposure samplings of the aerosol. Downstream of Valve 3, flow from Valve B can be supplied immediately after the exposure is terminated to deliver clean breathing air to maintain the

animals until they are removed from the exposure system.

### Exposure chamber

Exiting Valve 3, the aerosol enters the exposure system – a Jaeger–NYU Modular Nose-Only Directed-Flow Rodent Inhalation Exposure Unit (CH Technologies, Westwood, NJ, USA) (Jaeger 1994) (Nose-Only Inhalation Exposure System (NOIES), also commonly referred to as a *mouse tree*) – which exposes individual mice to the aerosolized agent. A nose-only system was chosen primarily to eliminate ophthalmic and enteric infections to the mice. The capacity of the NOIES to deliver infectious aerosol to mice was validated and verified by Jaeger *et al.* (2006).

Each mouse is placed in a polycarbonate holder and constrained with a sealed restraint inserted in the rear opening of the holder so that only the tip of the mouse's nose projects out of an opening in the front of the holder. The holder inserts securely into a socket on the NOIES, forming a seal. Vents inside the body of the NOIES blow an airstream containing the filtered aerosol at the nares of the mouse as her only source of breathing air, and sweeps away exhaled air and excess flow. The NOIES is a directed-flow system, and no mouse rebreathes flow from other mice. It can expose up to 12 mice at a time. A rotating joint inserted at the inlet to the NOIES allows it full range of rotation and makes all the sockets accessible.

Relative humidity (r.h.) and temperature of the effluent from the NOIES are measured by a National Institute of Standards and Technology (NIST)-traceable digital hygrometer (Control Company, Friendswood, TX, USA; Model 35519-020). The flow may be either sampled at Valve and Port 4 or exhausted through another HEPA canister filter, after which a flow meter (TSI; model no. 4143D) measures the flow rate.

### Viable measurements

The CATS is configured for sampling with impingers before (Port/Valve 1) and after the filter holder (Port/Valve 2) and in the effluent from the NOIES (Port/Valve 4). Aerosol flow from the port selected is combined with flow from needle Valve C in another porous tube diluter to achieve the design airflow rate ( $12.5 \text{ l min}^{-1}$ ) for the AGI-4 impingers (Ace Glass Inc., Vineland, NJ, USA). This combined flow is drawn through Valve and Port 5a or 5b into the impinger for a period of 5 min. Two impinger hook-ups are present in the system to allow the operator to switch quickly to a fresh impinger. A vacuum pump is used to draw air through the impingers and thence through a HEPA filter to capture uncollected

aerosol. The operator can also make measurements through the same ports (without dilution air) using particle sizing instruments.

### Initial validation of system engineering and function

After final assembly, the CATS was leak-checked by closing the system, pressurizing it to three inches of water and observing the pressure gauge. If leaks were detected, they were found and fixed, and the system was leak-checked again until the slight overpressure was maintained for an hour. Then, the CATS was run with DI water as the nebulizer medium and the filter holder empty, and the flow rate (set to  $5.3 \text{ l min}^{-1}$ ), temperature and r.h. at the exhaust were monitored over a period longer than an hour.

### Correlation of sampling ports

To determine the loss of particles within the system, and to ensure that samples from different ports can be compared with one another, a correlation of sampling ports on the instrument was performed by nebulizing two separate suspensions, one of 250-nm polystyrene latex (PSL) beads (Duke Scientific, Palo Alto, CA; G250) and one of  $1\text{-}\mu\text{m}$  PSL beads (Duke Scientific; 4009A). The suspension of beads supplied was diluted in 10 volumes of DI water as the nebulization liquid. The make-up airflow was adjusted to deliver a total flow of  $5.3 \text{ l min}^{-1}$ , and the system was allowed to equilibrate. No filter was used in this test.

Each of the sampling ports (1, 2 and 4) and the ports on the impinger hook-up (5a and 5b) was sampled repeatedly with the particle sizer, as were ports on each quadrant of the NOIES. Collections from the NOIES were accomplished by inserting the sampling tube into the tip of a mouse restraint device and installing the tube into a socket of the NOIES at each of the four quadrants. Valve C was closed during sampling through Ports 5a and 5b on the impinger hook-up. Because those connections are closed, adding dilution air would have flooded the particle sizer.

For  $1\text{-}\mu\text{m}$  beads, only one reading was taken at a time. The consistency was calculated based on the combined concentration at the aerodynamic diameter at which the peak occurred and the two surrounding data points. For 250-nm beads, readings were taken in triplicate at each port and the arithmetic mean of those three readings was used.

### Biological sampling validation

To test the consistency of the challenge delivered, a bioaerosol was created and flowed through the system, and

its viability (matched with its particle size distribution: see next section) was measured by collection in impingers and plating. At the time of this work, it was not known what challenge organism would be used in the animal trials, so two nonpathogenic test micro-organisms were chosen for this work: MS2 coliphage virus and *Bacillus atrophaeus* bacterial spores. The nominal particle size of an individual MS2 virus is about 27 nm (Prescott *et al.* 2002), and that of *B. atrophaeus* is 0.8–1.2  $\mu\text{m}$  (Pinzón-Arango *et al.* 2009).

Stock of MS2 virus, from American Type Culture Collection (ATCC) 15597-B1, was grown in *E. coli* (ATCC 15597) in tryptic soy broth (TSB) according to standard EPA protocols (EPA 2001), at a titre of  $10^{11}$  PFU  $\text{ml}^{-1}$ . The stock was diluted in filter-sterilized water to a nominal titre ranging from  $10^8$  to  $10^{10}$  PFU  $\text{ml}^{-1}$  and delivered into the nebulizer's reservoir. (The nominal titre is the concentration of viable micro-organisms in the liquid, calculated based on the original titre of the stock and the dilution ratio.) To determine the viability, a single-layer plaque assay was performed (EPA 2001).

*Bacillus atrophaeus* spores, from ATCC 9372 stock, were grown in TSB according to standard methods (Nicholson and Setlow 1990), at a titre of approximately  $10^8$  CFU  $\text{ml}^{-1}$ . The stock was diluted to a nominal titre of  $10^7$  to  $8 \times 10^7$  CFU  $\text{ml}^{-1}$  and delivered into the nebulizer. Samples containing *B. atrophaeus* were applied with a spiral plater (Microbiology International, Frederick, MD, USA) onto TSA plates and incubated overnight. Colonies were counted the next day using an automated colony counter (Microbiology International).

Three different filter media were used in these tests. A 47-mm circular punch and mallet were used to cut circular coupons from two filtering facepiece respirators (FFRs) available on the market, Safe Life T-5000 N95 FFRs (which contain the PSTI resin) and 3M 1860S N95 FFRs. Coupons were also cut from a NIOSH-approved N95 Filtering Facepiece Respirator (3M 1860S) media after treatment with isopropyl alcohol vapours and after prolonged exposure to medium-intensity X-rays in unsuccessful efforts to decrease the surface charge on the electret medium and lower the PRE.

After installation of a coupon of air filter medium in the holder, the Collison nebulizer was started and make-up flow was adjusted to deliver a total flow of  $5.3 \text{ l min}^{-1}$ , to match the face velocity employed in respirator testing at  $85 \text{ l min}^{-1}$ . Experiments took place at the ambient room temperature, 22–27°C; r.h. of the gas stream ranged from 45% to 65% but was consistent throughout each experiment. The CATS was allowed to equilibrate for 15 min before particle size measurements were taken at Ports 1 and 2, coordinated with impinger samples (see next section). Each MS2 experiment included 30 min of

post-equilibration run time; run times with *B. atrophaeus* were slightly longer (40 min) because impingers could not be operated simultaneously with the particle sizer.

Alternating between sampling Ports 1 and 2, air samples were drawn for 5 min into an AGI-4 impinger charged with  $1 \times$  phosphate-buffered saline (PBS) medium upstream and downstream of the filter. A practiced sequence of movements was used to prevent splash from the impingers. Another impinger was operated near the instrument during these tests to detect fugitive viable organisms.

### Particle size validation with bioaerosols

Paired with the impinger sampling, aerosol size measurements were taken using particle sizers at Ports 1 and 2. The particle size distribution (PSD) of the MS2 bioaerosol was measured using a scanning mobility particle sizer (SMPS; TSI). The SMPS consists of a Model 3080 electrostatic classifier with a 3081 long differential mobility analyzer and a 3785 condensation particle counter. Particles from 10 to 400 nm were sized using a scanning period of 135 s. For the SafeLife T-5000 medium, a PRE of 99.87% was measured from 100 to 300 nm by comparing PSDs before and after penetration of the filter. The PSD of the *B. atrophaeus* bioaerosol was measured from 0.5 to 20  $\mu\text{m}$  using an aerodynamic particle sizer (APS, Model 3321; TSI Inc.). The APS was operated for a sampling period of 20 s.

### Results

Variations in flow rate, r.h. and temperature affect both the PSD and the airborne viable concentration of bioaerosols. After system leaks had been eliminated, deviations from the mean for the temperature and the exhaust flow rate were lower than 1% for observations during a 90-min period, during which the r.h. remained constant within 5%. Toggling Valve C to turn flow to the impingers on or off caused a deviation in flow of about 2%.

Good uniformity of delivery to the individual ports of the NOIES was also observed. From tests using 1- $\mu\text{m}$  beads, the worst-case difference between ports was 4.8% of the overall mean and the largest deviation of any point from the mean of all measurements was 2.7%. In measurements using 250-nm beads, deviations were within 10% of the overall mean. The worst-case difference between ports was 15% of the overall mean. Single impingers sampling the air space around the CATS during tests that included aerosolization of bacteria or viruses detected no fugitive microbes during any trial.

Viable counts of *B. atrophaeus* micro-organisms were measured upstream, but concentrations of viable micro-



organisms downstream of the filter – even past the IPA-treated and X-irradiated 1860S samples – were below the detection limit of the impinger method. Plates from downstream samples grew an occasional lone colony, which was not enough to support reliable calculation of a PRE. This observation narrowed the list of candidate organisms by eliminating all but a very few bacteria. Viable counts of *B. atrophaeus* measured upstream of the filter are presented in Table 1. Viable penetration of MS2 through the same media in filter holders of the same design has been reported as a routine procedure (Heimbuch and Wander 2006; Franzot *et al.* 2008), and infectivity of bioaerosols delivered through the NOIES has been demonstrated by Jaeger *et al.* (2006).

From a linear regression analysis between the post-experiment titre of liquid recovered from the nebulizer reservoir (in CFU ml<sup>-1</sup>) and the airborne viable concentration measured in impingers sampling upstream from the filter (in CFU m<sup>-3</sup>), the viable spray factor (VSF) for *B. atrophaeus* in the CATS was determined to be  $7.8 \times 10^{-7}$  ml m<sup>-3</sup>. Including the reported collection efficiency of the impinger (Hogan *et al.* 2005) raises this value to  $\sim 9 \times 10^{-7}$  ml m<sup>-3</sup>. From this, the VSF at the Collison nozzle can be calculated to be  $\sim 2.4 \times 10^{-6}$  ml m<sup>-3</sup> by scaling by the ratio of total flow (5.3 l min<sup>-1</sup>) to flow through the Collison (2 l min<sup>-1</sup>). This is comparable to VSFs measured by Henderson (1952) for *B. subtilis* at the end of the spray tube in his apparatus ( $3.5 \times 10^{-6}$  to  $4.1 \times 10^{-6}$  ml m<sup>-3</sup>), which indicates that the nebulization method is operating without unusual losses in the CATS.  $R^2$  for the regression used to determine the VSF was a bit higher than 0.90, which demonstrates that the challenge atmosphere is acceptably repeatable as well.

Among the five experiments, the largest coefficient of variation (CV) for upstream airborne viable concentration in a single *B. atrophaeus* experiment was 26%;

however, the average of the coefficient of variations (CVs) is within the target value of 20% and the excursions are only slightly higher.

The PSD of aerosolized MS2 was observed to be approximately log-normal: a representative plot is given in Fig. 2. The diffusion dryer was not used in these tests, and it appears from the PSD that the particles may not have entirely dried; however, wetting of the filter was not observed. The PSD produced by aerosolizing *B. atrophaeus* was bimodal, particles in the peak near 1  $\mu$ m containing bacteria, and a broad peak of much smaller particles presumed to contain only dissolved solids from the aerosolization medium. Based on the representative distribution in Fig. 3, the dividing point between the two modes was taken as 0.8  $\mu$ m, the concentration of particles larger than 0.8  $\mu$ m was calculated, and the CV of that concentration was measured.

From each time step, the mean and standard deviation of the total particle count (TPC), count median diameter (CMD), and geometric standard deviation (GSD) of the aerosol distribution and the airborne viable concentration were calculated. For each individual experiment, the CV was calculated as the ratio of standard deviation of the time-based data points to the mean. CVs were calculated for each individual experiment: data were not pooled between experiments. The standard deviation was calculated for some experiments to show that it does not grow wildly compared to the GSD (Stone 2010). In no experiment were the statistics of the PSD observed to trend upward or downward. The moments of the PSD measured while aerosolizing MS2 are given in Table 2. As the data clearly show, the PSD for MS2 varied very little over the 30 min observed, as reflected in the very low CVs of the moments, all 6% or less. The corresponding data for *B. atrophaeus* appear in Table 3. The PSDs of *B. atrophaeus* were slightly more variable but the CVs of all sets of measurements were within 10%.

**Table 1** Viable concentrations and coefficient of variation (CVs) of viable concentration for *Bacillus atrophaeus* experiments

	Collison (10 <sup>6</sup> CFU ml <sup>-1</sup> )		Upstream (10 <sup>6</sup> CFU m <sup>-3</sup> )	CV of upstream (%)
	Nominal	Post exp.		
	10	26.30	23.30	19.21
	10	14.00	7.15	24.02
	16	2.80	3.04	18.23
	40	5.57	5.10	25.54
	80	18.00	12.40	5.00
Minimum	10	2.80	3.04	5.00
Maximum	80	26.30	23.30	25.54
Mean	32	13.30	10.20	18.40

Each maximum is the largest entry of data in the above column. Each minimum is, similarly, the smallest entry. Each mean averages the data in the corresponding column. A coefficient of variation (CV) is calculated for each individual experiment. These data are based on  $n = 3$  time-series measurements.

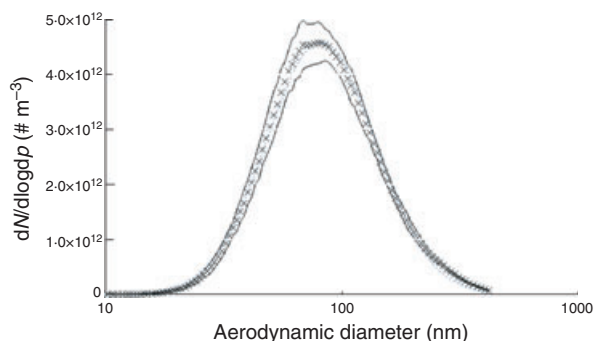

**Figure 2** Representative particle size distribution from MS2 nebulization and 95% confidence intervals for each individual diameter. Based on six samples in one experiment. x, measured datum; - - -, fitted log-normal curve; —, 95% confidence interval.

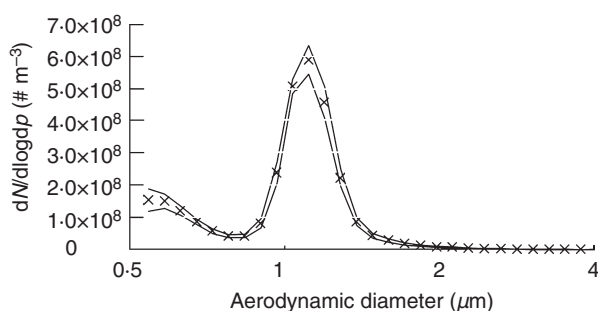

**Figure 3** Representative particle size distribution from nebulization of *Bacillus atrophaeus* and 95% confidence intervals. Taken from seven samples in one experiment. x, measured datum; —, 95% confidence interval.

Particle counts at Port 2 were too close to the instrument measurement limit to be useful for measuring consistency (because of the high filtration efficiency of the test filter), but downstream measurements were taken to verify filter integrity. Because the measurements of penetration were too close to the instrument detection limit, the most useful observable parameter of the filter was its  $\Delta p$ , which did not observably change over the course of any experiment.

## Discussion

A systematic evaluation of the CATS began with mechanical and environmental properties of the airstream and its containment. Uniformity of temperature and that of flow rate were shown to be excellent,  $\pm 1\%$  for each, for longer than the maximum duration (60 min) planned for animal exposure studies; r.h. concurrently varied by  $\pm 5\%$ . These values compare well with the literature – Bonnet *et al.* (2000) maintained r.h. within  $\pm 5\%$  in their system to simulate exposure to polynuclear aromatics in asphalt vapour and minimize excursions in flow rate, r.h. and temperature as sources of experimental noise.

Uniformity of delivery of particles to the NOIES ports was next demonstrated: deviations at individual ports from the measured mean were  $< 3\%$  at the dimension of bacteria ( $\sim 1 \mu\text{m}$ ) and  $< 10\%$  at a dimension typical of many viruses (250 nm), a value smaller than that measured on the much larger animal exposure system built by Oldham *et al.* (2009) for toxicology studies. Larger particles were not examined for two reasons: the polypropylene electret air filter media used in this study functionally exclude particles

**Table 2** Particle size distribution statistics and coefficient of variations (CVs) for MS2 experiments

	TPC ( $10^{12} \# \text{m}^{-3}$ ) *	CMD (nm) †	GSD‡	CV of§		
				TPC (%)	CMD (%)	GSD (%)
	2.65	81.41	1.70	4.66	1.23	0.19
	4.51	74.22	1.69	5.21	3.09	1.02
	4.16	75.72	1.68	3.31	1.20	0.21
	5.13	75.62	1.72	3.16	1.93	0.56
	4.51	76.53	1.70	6.00	0.49	0.08
	4.11	77.96	1.70	5.15	0.37	0.29
Minimum	2.65	74.22	1.68	3.16	0.37	0.08
Maximum	5.13	81.41	1.72	6.00	3.09	1.02
Mean	4.18	76.91	1.70	4.58	1.38	0.39

The lower portion of the table is calculated as in Table 1. All experiments used the T-5000 filter medium. These data are based on  $n = 6$  time-series measurements.

\*Total particle count.

†Count median diameter.

‡Geometric standard deviation.

§Coefficient of variation.

**Table 3** Particle size distribution statistics for *Bacillus atrophaeus* experiments

	Total particle count (TPC) ( $10^6 \# \text{ m}^{-3}$ )	TPC > 0.8 $\mu\text{m}$ ( $10^6 \# \text{ m}^{-3}$ )	CMD ( $\mu\text{m}$ ) ‡	GSD†	Coefficient of variation of			
					TPC (%)	TPC > 0.8 $\mu\text{m}$ (%)	CMD (%)	GSD (%)
	123.0	73.30	1.080	1.33	5.21	3.12	0.69	0.42
	59.2	49.30	1.100	1.21	7.42	5.26	0.60	0.58
	30.8	6.56	0.705	1.35	9.77	9.66	6.18	0.77
	254.0	121.00	0.953	1.33	6.81	3.64	0.70	0.15
	259.0	120.00	0.942	1.34	5.00	4.58	0.35	0.08
	528.0	254.00	0.948	1.34	3.84	4.21	0.42	0.22
	1208.0	580.00	0.951	1.34	9.21	4.97	0.91	0.19
	1174.0	590.00	0.960	1.34	3.52	4.94	0.30	0.14
Minimum	30.8	6.56	0.705	1.21	3.52	3.12	0.30	0.08
Maximum	1208.0	590.00	1.100	1.35	9.77	9.66	6.18	0.77
Mean	455.0	224.00	0.955	1.32	6.35	5.05	1.27	0.32

The lower portion of the table is calculated the same as Table 1. These data are based on  $n = 7$  time-series measurements.

‡Count median diameter.

†Geometric standard deviation.

larger than  $\sim 1 \mu\text{m}$ , and during testing of practical media and other devices, penetrating particles will almost exclusively be smaller than  $1 \mu\text{m}$ .

Barret and Rousseau (1998) showed that the behaviour of polypropylene electret filters varies widely depending on how the fibres of the media were made, and that some can be made to lose PRE without showing a change in  $\Delta p$ . However, their experiments delivered NaCl and dioctyl phthalate (DOP) aerosols specifically intended to lower the PRE of electrets. DOP is a strong plasticizer, and plasticizers do not appear in bioaerosol tests. Whereas salt may appear in a microbial stock, Barret and Rousseau were delivering a challenge of  $15 \text{ mg m}^{-3}$  of NaCl particles – a far larger mass concentration than encountered in a realistic bioaerosol test – at similar face velocity for nearly 3 h. In a representative experiment in the CATS, the total mass concentration of the challenge was only about  $0.6 \text{ mg m}^{-3}$  for no more than an hour, and a small fraction of that mass was salt. No previous studies challenging PSTI electret media have shown a significant change in PRE under moderate bioaerosol loading, and the bioaerosol challenges delivered by the CATS do not approach the capacity of Barret and Rousseau's aerosol challenges to reduce PRE.

As expected, the final property, viability, showed the largest variability. The criterion of an average CV of 20% was met, but the variation was larger than that observed by Henderson (1952), who reported a worst-case CV of 10.4% for a *Bacillus* spore. As CVs for concurrent particle dimension measurements were within a 10% window, we attribute part of the CV in viability measurements to the plating process.

A practical limitation was illustrated during this study: the Collision nebulizer delivers a small volume of aerosol

and some loss of viability accompanies the aerosolization of microbes. The two factors combine to impose a cap on the bioaerosol challenge that can be delivered and, in turn, on the upper limit of removal efficiency that can be measured. Until a mechanism is available for the delivery of viable aerosols at higher concentration, this constraint will continue.

In sum, the CATS, as designed and built, provides a novel experimental capability – to expose rodents, by inhalation alone, to infective (and, by extension, other toxic) aerosols that have passed through a filter or other air treatment device – and its mechanical performance has been validated. From the data measured in this work, and reasoning based on the literature, one can conclude that the downstream PSD and viable airborne concentration remain steady for long enough to accurately deliver the challenges. The next step is to select an appropriate viral pathogen and susceptible animal to illustrate the use of the CATS. To evaluate the clinical merit of PSTI in the N99 medium, it will be necessary either to substitute an aerosolization technique that delivers a more-concentrated viable aerosol or to concentrate the aerosol after generation. The latter approach is plausible because viable concentration is measured in the stream delivered to the animals. Other noncontact antimicrobial principles (e.g. an energy-based technology such as singlet oxygen or ultraviolet radiolysis) could likewise be tested in the CATS, and this demonstration also implies that the effect of leakage around the protective device can be evaluated using the same technology.

The CATS is a prototype device, tailored to fit a specific aerosol containment enclosure.

Several enhancements are possible: temperature is controlled at the conditions in the enclosure, which could be



regulated to operate at higher or lower temperatures; in an enclosure of more-forgiving dimensions, the tubing runs could be shortened considerably and the turns eliminated to decrease losses to the walls; redesigning the filter holder to increase the area tested would support testing at lower face velocities, permitting characterization of dependence of the efficacy of the treatment being examined on peak instantaneous airflow. The desirability of concentrating the aerosol to lower the detection limit is mentioned above.

## References

- Barret, L.W. and Rousseau, A.D. (1998) Aerosol loading performance of electret filter media. *Am Ind Hyg Assoc J* **59**, 532–539.
- Bonnet, P., Binet, S., Brandt, H., Kriech, A.J., Lafontaine, M., Nunge, H., Morel, Y., de Groot, P. *et al.* (2000) Inhalation study on exposure to bitumen fumes. Part 1: development and Validation of the Equipment. *Ann Occup Hyg* **44**, 15–29.
- Brankston, G., Gitterman, L., Hirji, Z., Lemieux, C. and Gardam, M. (2007) Transmission of influenza a in human beings. *Lancet Infect Dis* **7**, 257–265.
- Burmester, B.R. and Witter, L. (1972) Efficiency of commercial air filters against Marek's disease virus. *Appl Microbiol* **23**, 505–508.
- Cecchini, C., Verdenelli, M.C., Orpianesi, C., Dadea, G.M. and Cresci, A. (2004) Effects of antimicrobial treatment on fiberglass–acrylic filters. *J Appl Microbiol* **97**, 371–377.
- Cheng, Y.S. and Moss, O.R. (1995) Inhalation exposure systems. In *Concepts in Inhalation Toxicology* eds McClellan, R.O. and Henderson, R.F. pp. 25–66. Boca Raton, FL: CRC.
- Dee, S., Batista, L., Deen, J. and Pijoan, C. (2005) Evaluation of an air-filtration system for preventing aerosol transmission of porcine reproductive and respiratory syndrome virus. *Can J Vet Res* **69**, 293–298.
- Dee, S., Batista, L., Deen, J. and Pijoan, C. (2006a) Evaluation of systems for reducing the transmission of porcine reproductive and respiratory syndrome virus by aerosol. *Can J Vet Res* **70**, 28–33.
- Dee, S., Deen, J., Cano, J.P., Batista, L. and Pijoan, C. (2006b) Further evaluation of alternative air-filtration systems for reducing the transmission of porcine reproductive and respiratory syndrome virus by aerosol. *Can J Vet Res* **70**, 168–175.
- Drew, R.T. and Laskin, S. (1973) Environmental inhalation chambers. In *Methods of Animal Experimentation Vol. 4* ed. Gay, W.I. pp. 1–41. New York, NY: Academic Press.
- Eninger, R.M., Adhikari, A., Reponen, T. and Grinshpun, S.A. (2008) Differentiating between physical and viable penetrations when challenging respirator filters with bioaerosols. *Clean* **36**, 615–621.
- EPA (2001) *US EPA Manual of Methods for Virology*. Ohio, OH: Cincinnati.
- Fiegel, J., Clarke, R. and Edwards, D.A. (2006) Airborne infectious disease and the suppression of pulmonary bioaerosols. *Drug Discovery Today* **11**, 51–57.
- Foarde, K.K., Hanley, J.T. and Veeck, A.C. (2000) Efficacy of antimicrobial filter treatments. *ASHRAE Journal* **42**, 52–58.
- Franzot, S., Gendron, A.-M., Staffa, A., Ohayon, D., SansCartier, M.-É., St-Denis, C. and Low, K. (2008) *Individual and Collective Protection Program—Final Report*. Technical report 48637-CH. 1, NC: Army Research Office, Research Triangle Park.
- Gardam, M. and Lemieux, C. (2007) Reflection and reaction—transmission of influenza a in human beings—authors' reply. *Lancet Infect Dis* **7**, 761–763.
- Heimbuch, B.K. and Wander, J. (2006) *Bioaerosol Challenges to Antimicrobial Surface Treatments: Enhanced Efficacy against MS2 Coli Phage of Air Filter Media Coated with Polystyrene-4-methyltrimethylammonium Triiodide*. Technical report AFRL-ML-TY-TR-2006-4527. FL: Air Force Research Laboratory, Tyndall AFB.
- Heimbuch, B.K., Proudfoot, E., Wander, J., Laventure, G., McDonald, R. and Burr, E. (2004) Antimicrobial Efficiency of Iodinated Individual Protection Filters. Proceedings of the Scientific Conference on Chemical and Biological Defense Research, Hunt Valley, MD, Nov 15–17; Technical Report ECBC-SP-020, Edgewood Arsenal, MD.
- Henderson, D.W. (1952) An apparatus for the study of airborne infection. *J Hyg* **50**, 53–68.
- Hogan, C.J., Kettleison, E.M., Lee, M.-H., Ramaswami, B., Angenent, L.T. and Biswas, P. (2005) Sampling methodologies and dosage assessment techniques for submicrometre and ultrafine virus aerosol Familynameprefixs. *J Appl Microbiol* **99**, 1422–1434.
- Hopkins, S.R. and Drury, L.N. (1971) Efficacy of air filters in preventing transmission of newcastle disease. *Avian Dis* **15**, 596–603.
- Jaeger, R.J. (1994) *Modular Reversible-Flow-Past Nasopulmonary Respiratory Dosing System for Laboratory Animals*. U.S. Patent 5,297,502.
- Jaeger, R.J., Shami, S.G. and Tsenova, L. (2006) Directed-flow aerosol inhalation exposure systems: applications to pathogens and highly toxic agents. In *Inhalation Toxicology*, 2nd edn. eds Salem, H. and Katz, S.A. pp. 73–90. FL: CRC, Boca Raton.
- Lee, V.R. (2007) Reflection and reaction—transmission of influenza a in human beings. *Lancet Infect Dis* **7**, 760–761.
- Lee, J.-H. and Wu, C.-Y. (2006) *Evaluation of the Performance of Iodine-Treated Biocide Filters Challenged with Bacterial Spores and Viruses*, Technical report AFRL-ML-TY-TR-2007-4510. Tyndall AFB, FL: Air Force Research Laboratory.
- Lee, J.-H., Wu, C.-Y., Lee, C.N., Anwar, D., Wysocki, K.M., Lundgren, D.A., Farrah, S., Wander, J. *et al.* (2009)

- Assessment of iodine-treated filter media for removal and inactivation of MS2 Bacteriophage aerosols. *J Appl Microbiol* **107**, 1912–1923.
- Lemieux, C., Brankston, G., Gitterman, L., Hirji, Z. and Gardam, M. (2007) Questioning aerosol transmission of influenza. *Emerg Infect Dis* **13**, 173–174.
- MacFarland, H.N. (1983) Designs and operational characteristics of inhalation exposure equipment—a review. *Fund Appl Toxicol* **3**, 603–613.
- Marchin, G. and Fina, L. (1989) Contact and demand–release disinfectants. *Crit Rev Environ Sci Technol* **19**, 277–290.
- McFarlane, A.S. (1956) Labeling of plasma proteins with radioactive iodine. *Biochem J* **62**, 135–143.
- Messier, P.J. (2000) *Iodine/resin disinfectant [,] a procedure for the preparation thereof* U.S. Patent 6045820.
- Nicholson, W.L. and Setlow, P. (1990) Sporulation, germination and outgrowth. In *Molecular Biology Methods* for eds Harwood, C.R. and Cutting, S.M. pp. 391–450. New York, NY: Bacillus Wiley.
- Oldham, M.J., Phalen, R.F. and Budiman, T. (2009) Comparison of predicted and experimentally measured aerosol deposition efficiency in BALB/c mice in a new nose-only exposure system. *Aerosol Sci Technol* **43**, 970–977.
- Pinzón-Arango, P.A., Scholl, G., Nagarajan, R., Mello, C.M. and Camesano, T.A. (2009) Atomic force microscopy study of germination and killing of *Bacillus atrophaeus* spores. *J Molecular Recognition* **22**, 373–379.
- Prescott, L.M., Harley, J.P. and Klein, D.A. (2002) *Microbiology*. New York, NY: McGraw–Hill Companies Inc.
- Price, D.L., Simmons, R.B., Ramey, D.L., Crow, S.A. and Ahearn, D.G. (1993) Assessment of Air Filters Treated with a Broad Spectrum Biostatic Reagent. In *Indoor Air '93*, Proceedings of the 6th International Conference on Indoor Air Quality and Climate, Helsinki, Finland, July 4–8. pp. 572–532.
- Ratnesar-Shumate, S., Wu, C.-Y., Wander, J., Lundgren, D., Farrah, S., Lee, J.-H., Wanakule, P., Blackburn, M. et al. (2008) Evaluation of Physical Capture Efficiency and Disinfection Capability of an Iodinated Biocidal Filter Medium. *Aerosol Air Qual Res* **8**, 1–18.
- Rengasamy, S., Fisher, E. and Shaffer, R.E. (2010) Evaluation of the survivability of MS2 viral aerosols deposited on filtering face piece respirator samples incorporating antimicrobial technologies. *Am J Infect Control* **38**, 9–17.
- Stone, B.R. (2010) *Consistency and Reproducibility of Bioaerosol Delivery for Infectivity Studies on Mice*. M.S. thesis, University of Florida, Gainesville, FL, 2010; reprinted as AFRL-TY-TP-2010-0037, Air Force Research Laboratory, Tyndall AFB, FL.
- Sullivan, P.D. (2006) *Evaluation of Low-Pressure Drop Antimicrobial and Hybrid Air Filters*, Technical report AFRL-ML-TY-TR-2006-4526. Tyndall AFB, FL: Air Force Research Laboratory.
- Tang, J.W. and Li, Y. (2007) Reflection and reaction—transmission of influenza a in human beings. *Lancet Infect Dis* **7**, 758.
- Taylor, S.L., Fina, L.R. and Lambert, J.L. (1970) New water disinfectant: an insoluble quaternary ammonium resin–triiodide combination that releases bactericide on demand. *Appl Microbiol* **20**, 720–722.
- Tellier, R. (2006) Review of aerosol transmission of influenza a virus. *Emerg Infect Dis* **12**, 1657–1662.
- Tellier, R. (2007a) Questioning aerosol transmission of influenza: in response. *Emerg Infect Dis* **13**, 174–175.
- Tellier, R. (2007b) Reflection and reaction—transmission of influenza a in human beings. *Lancet Infect Dis* **7**, 759–760.
- Verdenelli, M.C., Cecchini, C., Orpianesi, C., Dadea, G.M. and Cresci, A. (2003) Efficacy of antimicrobial filter treatments on microbial colonization of air panel filters. *J Appl Microbiol* **94**, 9–15.
- Wong, B.A. (2007) Inhalation exposure systems: design, methods, and operation. *Toxicol Path* **35**, 3–14.