INTERCELLULAR COMMUNICATION AND TISSUE GROWTH

I. Cancerous Growth

WERNER R. LOEWENSTEIN and YOSHINOBU KANNO

From the Cell Physics Laboratory, Department of Physiology, College of Physicians and Surgeons, Columbia University, New York

ABSTRACT

Intercellular communication was examined with intracellular electrical techniques in primary and transplanted rat liver cancers. Normal liver cells communicate rather freely with each other through permeable junctional membranes. Cancer liver cells show no communication at all; their surface membrane is a strong barrier to diffusion all around the cell. Cancer cells induce alterations in membrane permeability in normal liver cells; communication among the latter is markedly reduced when cancer cells grow near them.

INTRODUCTION

Evidence for direct cell-to-cell communication is now available for a wide variety of epithelial tissues (12, 12 *a*, 17). At the surfaces of cell contact (*junctional surfaces*), the cell membranes in, at least, some of these tissues are normally so permeable that many cellular substances may diffuse rather freely from one cell interior to the next. The present series of papers deals with the question of whether cellular communication of this sort is involved in the control of tissue growth.

It has long been evident that normal growth of tissues depends on some form of contact interaction between cells. Harmonious growth requires, among other things, that cells recognize each other and stop moving and growing at the right place. Instructive, in this respect, is the movement of epidermal cells over a wound; the movement stops when the cells meet (10). Particularly in-

structive is the behavior of cells in tissue culture growing on glass surfaces. The cells stop moving and dividing when they establish contact with each other, and stop only then (1, 24). Some kind of signal appears to be transmitted from cell to cell upon contact. The question here, then, is whether diffusion of substances from cell interior to cell interior is involved in the signal transmission.

A direct approach to the question seems hopeless until specific signal substances are identified. But one may try an indirect approach and see whether cellular communication is altered in situations of uncontrolled cellular growth. Here, we shall explore this point in cells showing the most notorious lack of growth control, cancer cells. Cancer cells, unlike normal ones, neither stop moving nor dividing upon cellular contact, as is seen particularly clearly in tissue culture (2, 5-7, 23*a*).

Among the techniques now available for testing intercellular communication (cf. reference 12), we chose an electrical one. It consisted essentially of injecting a current of ions into a cell and determining what fraction of the current passes into an adjacent cell. The method is readily applicable to many cell systems and provides quantitative information (9, 13, 17). Liver cells were used for the study. These provide a suitable material: the cells are sufficiently large and stable to be impaled with micropipettes; they have, normally, good intercellular communication (20); and their cancerous counterparts are readily available in a variety of transplantable forms.

A brief account of the present results has already appeared (14).

METHODS

ELECTRICAL MEASUREMENTS: The experiments were done on rat liver. The animals were killed by rapid traction on the first cervical vertebrae. The normal or cancerous liver was isolated from the animal within 1-2 min after death and set up in a bath of Krebs' solution for measurement of intercellular

communication. Four microelectrodes were inserted, under observation in a compound microscope, into two adjacent liver cells, as illustrated in Fig. 1 *a*. Two electrodes served to pass rectangular pulses of current between the interior and exterior (grounded) of each cell, and the other two, to record the resulting membrane voltages (V_I , V_{II}) across the cell membranes of each cell. In our later experiments, a single electrode connected to a balanced bridge circuit performed both the current-passing and the voltage-recording functions in one of the cells (Fig. 1 *b*). The constant current generator (P) was coupled to the bridge by means of an electro-optical isolating circuit developed in our laboratory (3), which minimized capacitive imbalance of the bridge. The ratio of membrane voltages V_{II}/V_I provided a convenient index of intercellular communication. The method provides, at the same time, direct measures of the resistance between cell interior and exterior. Thus, cell membrane integrity and cell membrane sealing around the microelectrodes could be tested continuously during the measurements. (For a detailed description of the general technique, see references 13 and 15).

Most measurements were done on cells of the liver surface and, whenever possible, on the surface of the liver edge. At the liver edge, cells could be viewed di-

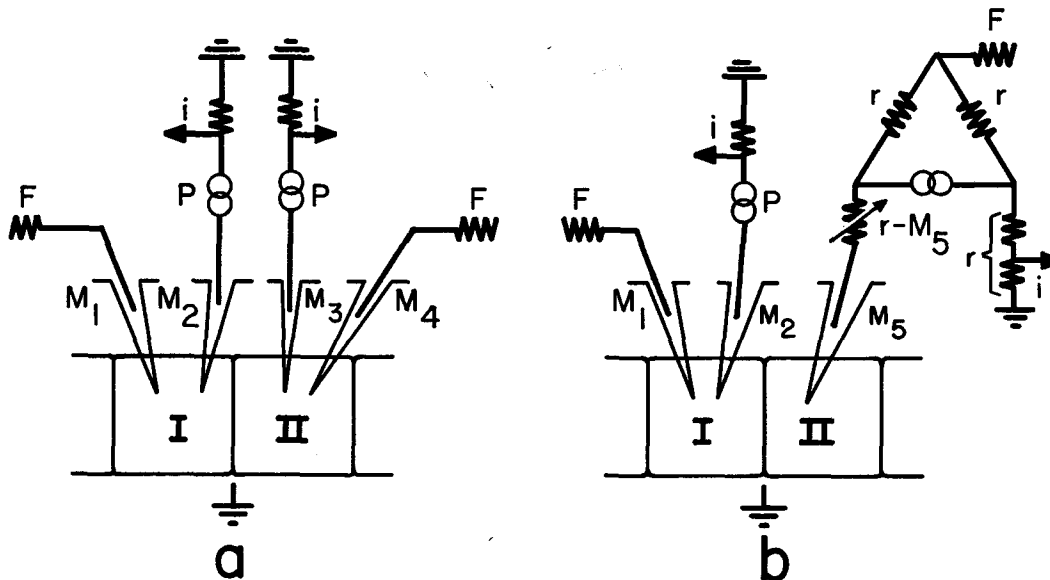

FIGURE 1 Arrangements for measuring intercellular communication. M_2 , M_3 , current-passing microelectrodes. M_1 , M_4 , voltage-recording microelectrodes. M_5 , microelectrode connected to a balanced bridge serving both current-passing and voltage-recording functions ($r = 30 \text{ m}\Omega$; $M_5 = 10 \text{ to } 30 \text{ M}\Omega$). Currents are supplied by constant current generators (P) coupled electro-optically to the electrodes. Voltages are fed into two separate beams of an oscilloscope through field transistor input stages (F) compensating for electrode impedance. Currents are measured across $1 \text{ M}\Omega$ resistors (i) and displayed on the other two oscilloscope beams.

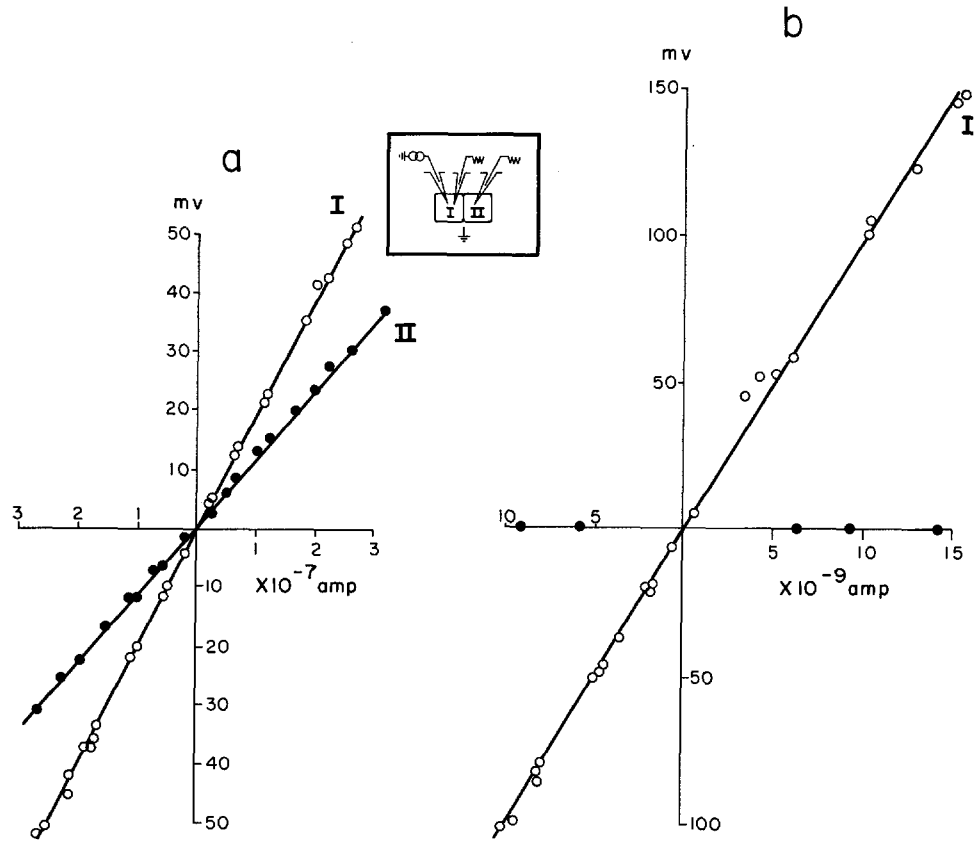

FIGURE 2 Membrane current-voltage relation in normal (a) and cancer liver cells (azodye-induced primary liver cancer) (b). Current (abscissae) is passed between the cell interior of one cell (I) and the cell exterior, and the resulting resistive membrane voltage (ordinates) is measured simultaneously in cell I and in adjacent cell II. Outward current, right; depolarization, upwards. Note different scales in a and b.

rectly in transillumination, which facilitated greatly the insertion and precise positioning of the electrodes. For measurements on the remainder of the liver surface and in the depth of the liver, intracellular positions of the electrodes were recognized by membrane potentials (at zero current) and membrane resistances. The measurements, including the time of liver isolation, lasted from 20 min to 1½ hr. The livers were kept at 4–6°C throughout the measurements. At this temperature, the conductive properties of the normal and cancerous liver cells were stable for the entire duration of the measurement.

CONTROL MEASUREMENTS: A series of control experiments was performed in livers with intact circulation *in situ* in unanesthetized decerebrate and spinal animals. The resting cell membrane potentials averaged 38 mv (inside negative) as against 30 mv in isolated liver. However, the ratios V_{II}/V_I and resist-

ances between cell interior and exterior were similar to those in isolated liver, and hence the conductive properties of both junctional and nonjunctional cell membranes were similar; these are the properties with which we are concerned in the present study.

HISTOLOGICAL EXAMINATION: Standard histopathological techniques were used to examine the cancer material. Generally, a sample of the cancerous tissue on which electrical measurements had been made was examined histologically. This was sufficient for most experiments, since the cells of any given cancer nodule were quite homogeneous in their electrical properties. In the kind of experiments, such as those exemplified in Figs. 6 and 7, in which a close correspondence between electrical and histological examinations was desired, the cells or cell region from which electrical recordings were taken were marked with dyes.

MATERIALS: The following types of liver cancer were used. Primary cancer: induced by 3'-methyl-4-dimethylamino-azo-benzene, fed in a modified diet, No. 3 of Miller et al. (18), for 25 wk to rats of the Carwork CFN strain (Carwork Farms, New York, N.Y.). The diet contained 18% casein, 1.0 mg Riboflavin per kg; and 0.058% of the azo dye above. Transplanted cancers: Morris' hepatoma Nos. 7793 and 7787; and Novikoff's hepatoma. The cancer-carrying animals were kindly provided to us, in order of quotation, by Dr. S. Sorof, Institute for Cancer Research, Philadelphia, Dr. J. Roth, University of Connecticut, and Dr. E. Hirschberg, Columbia University.

The normal liver material was obtained from animals of the same genetic strain used for transplanting Novikoff's hepatoma, and from unselected white laboratory rats.

across the junctional membrane surfaces. Ion communication between liver cells is thus detectable electrically over distances many cells long in all directions throughout the liver (Fig. 6 *a* and 7). All parenchymal cells of the normal liver are interconnected (20).

Cancerous liver cells, on the other hand, have no detectable communication at all. Fig. 2 *b* shows an example in a primary liver cancer, the counterpart of the experiments of Fig. 2 *a*. Here there is no resistive voltage at all recordable in cell *II*. The communication ratio is less than 0.002, the limit of resolution of our method.

The communication ratio in a connected cell system, as illustrated in Fig. 3, decreases with increasing resistance of the junctional membrane

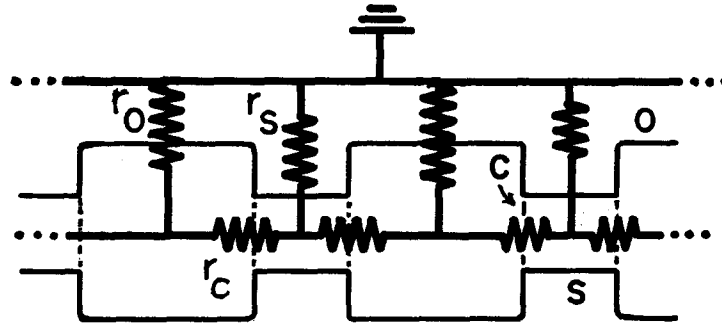

FIGURE 3 Two-dimensional scheme and electrical equivalent of communicating cell system. r_c , junctional membrane resistance; r_o and r_s , resistance components of the nonjunctional membranes (see reference 12 for requirements of r_s).

RESULTS AND DISCUSSION

Lack of Communication between Cancer Cells

Fig. 2 *a* illustrates an experiment in which an ion current is passed between the interior and exterior of a cell (*I*) of the rat liver surface, and the resulting resistive membrane voltages are measured in this cell and simultaneously in an adjacent one (*II*). As in many other types of epithelial cells (12, 17), the resistance of the surface membrane of the liver cell is quite ohmic: the membrane shows no sign of electrical excitation and little or no rectification to a wide range of current. Most striking is the small difference in resistive membrane voltage in the two cells. The ratio of the voltages, V_{II}/V_I , (hereafter referred to as *communication ratio*) is, on the average, 0.6; which means that a considerable fraction of the current injected into cell *I* flowed into the adjacent cell *II*

(*junctional membrane resistance, r_c*) and increases with the surface resistance of the system (*nonjunctional surface membrane resistance*, in effect a parallel combination of the r_o and r_s elements). A low communication ratio, such as the one found in cancer cells, may thus conceivably be due to: (*a*) a high junctional membrane resistance, that is, to truly poor intercellular communication; (*b*) a low nonjunctional surface membrane resistance; and (*c*)—a more trivial cause—leaks in the nonjunctional membrane surface introduced by the experimental procedures (for instance, a possibility to be considered was that cancer cells rupture more easily or seal less perfectly upon electrode penetration than do normal cells). Possibility (*b*) is eliminated as a sufficient cause by the results of experiments of the type illustrated in Fig. 2 *b* which show the resistance measured between cell interior and exterior (hereafter called *input resistance*) to be

actually larger in the cancer cell ($10^7 \Omega$) than in the normal cell ($10^5 \Omega$) (see also Table I). This, however, does not necessarily eliminate possibility (c) without statistical analysis of data of many experiments of the kind illustrated in Fig. 2 b (for instance, cell II could conceivably be leaky in many trials). Rather than rely on such statistical analysis, we preferred the more direct approach of measuring the input resistance simultaneously in the two test cells by placing a current source inside each of the two (Fig. 1 a and b, Methods). In this way, cell membrane integrity could be checked

routinely and simultaneously with measurements of communication ratio. The somewhat more elaborate circuitry which this procedure required was well worth making, in view of the quality of the information and the certainty which it provided. The procedure, in its four-electrode and three-electrode forms, became our standard method for testing cell communication in cancer cells.

Fig. 4 a-c illustrates a typical result. Two adjacent cancer cells with clearly intact surface membrane barriers (a) show no intercellular communication (b, c). Fig. 4 e-f shows the excellent

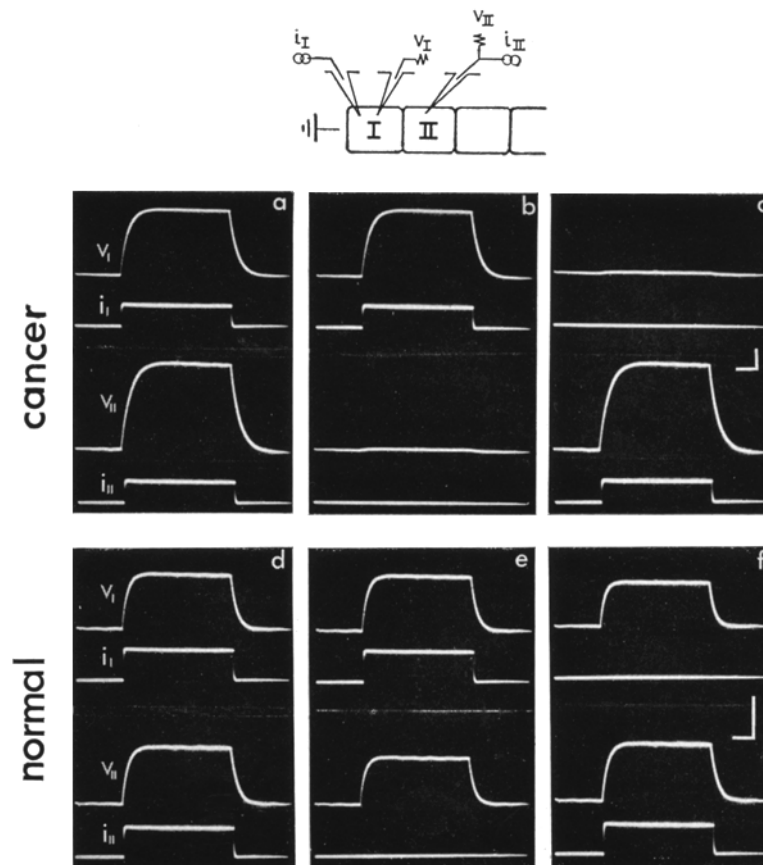

FIGURE 4 Lack of communication in cancer cells (Novikoff rat liver cancer). a: To test integrity of surface membranes, current ($i_I = 9 \times 10^{-9}$ A) is passed from a microelectrode inside cell I to cell exterior (grounded), and the resulting voltage (V_I) is recorded with another microelectrode in this cell (upper two oscilloscope traces). Current is then passed through the adjacent cell II ($i_{II} = 1.8 \times 10^{-8}$ A) and voltage recorded in cell II (lower two traces). (In cell II the same microelectrode, connected to a balanced bridge circuit, serves for both passing of current and recording of voltage). b and c: To test intercellular communication, current is passed alternatively from cell I (b) and from cell II (c), and the voltages are recorded simultaneously in the two cells. For a comparison a similar sequence is shown in d-f for normal rat liver cells ($i_I = 1.3 \times 10^{-7}$ A; $i_{II} = 2.8 \times 10^{-7}$ A). Calibration all records: voltage, 10 mv; time, 20 msec.

communication between normal cells, for a comparison.

This is illustrated further by measurements of cell-to-cell resistance in which the cell exterior is effectively bypassed as a medium for current flow by surrounding the cells by isotonic sucrose, a medium of high resistivity, and current is passed directly from one cell to the next, as diagrammed in Fig. 5. The resistances so measured between cancer cells were 10^7 – $10^8 \Omega$, in all cases several orders of magnitude greater than the resistances between normal cells.

A major difference between cancer and normal cells resides thus in the resistance to ion diffusion from cell to cell. While the cells of normal liver form a functional continuum, so far as at least some of their ion content is concerned, the cells of cancerous liver behave like functional units.

An estimate of the difference in terms of membrane permeability was recently obtained by three-dimensional analog computation, aided in part by solutions kindly provided to us by Dr.

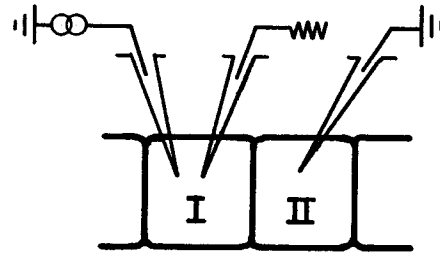

FIGURE 5 Electrode arrangement for measuring junctional resistance. In cell I, current source and voltage-recording electrodes. In cell II, electrode common to current-passing and recording circuits. Preparation lies in isotonic sucrose. (The resistance of the electrode in II is determined with a current pulse equal to that used for junctional resistance determination.)

Westcott Vayo. The procedural aspects of the computations and the details of the results will be published elsewhere; but the chief result is of sufficient interest here to be mentioned: the computed junctional membrane permeabilities in

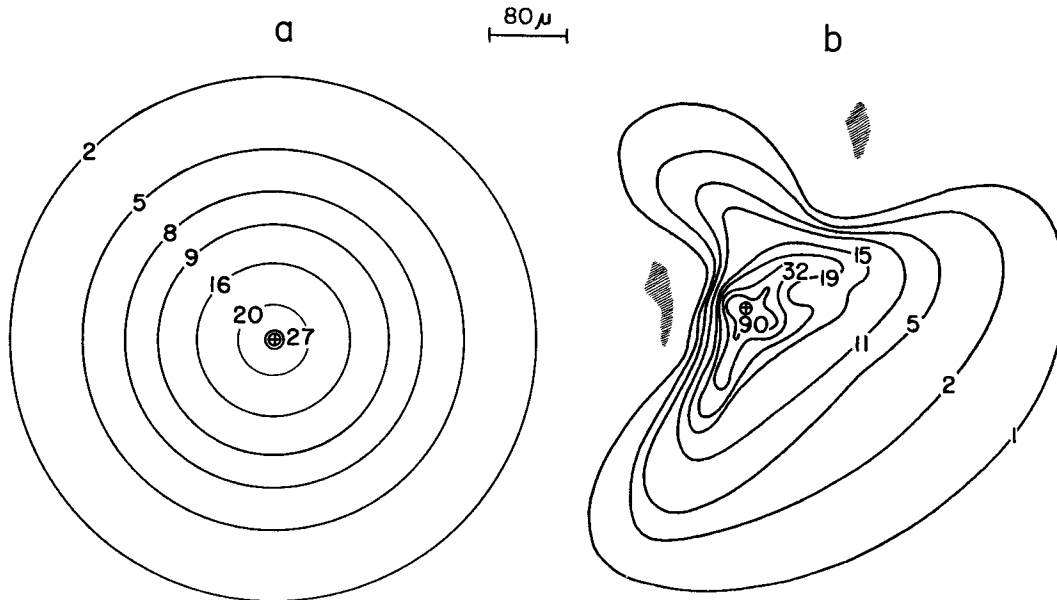

FIGURE 6 Changes in cell communication during cancer invasion. Current pulses of constant intensity are passed with a microelectrode fixed inside a cell of the liver surface (marked by cross), and the field of resulting resistive membrane voltage is probed with a roving microelectrode from inside cells of the liver surface. The figures are surface maps with roughed-in lines of equipotentials; the numbers give the resistive voltages. A rough representation of the electrical field is shown in *a*, normal liver (current, 1.7×10^{-7} A); and *b*, a liver region with histologically normal appearance in the vicinity of which the first groups of transplanted cancer cells are attaching (hatched area) (1.1×10^{-7} A). Each equipotential line is constructed from 5 to 20 recording points.

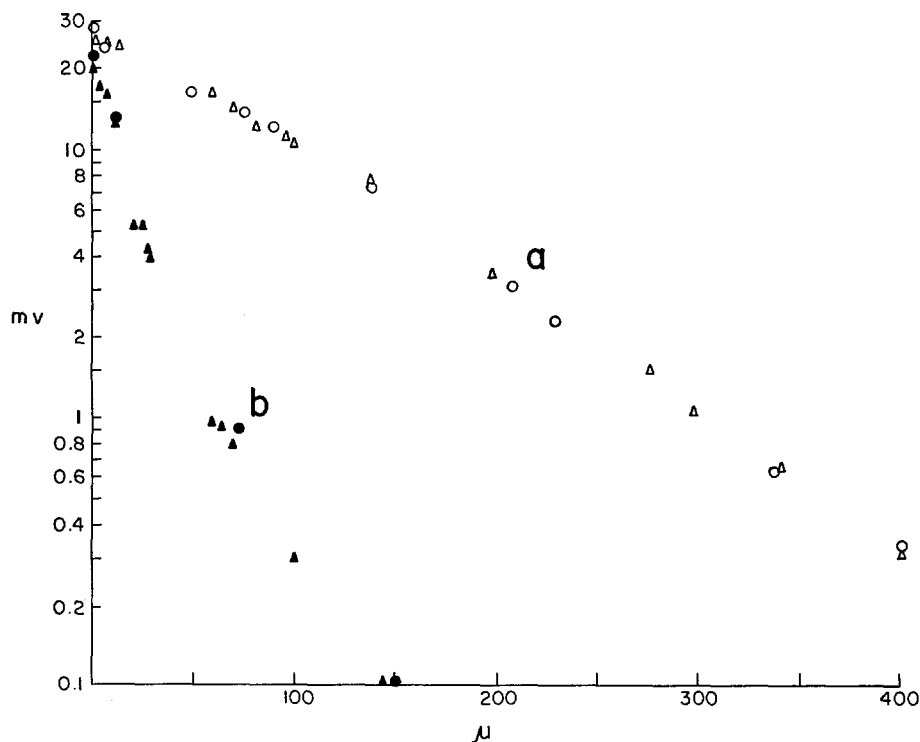

FIGURE 7 Alterations in communication induced by cancer cells. Current is passed with an electrode inside one cell of the liver surface, and the resulting resistive membrane voltages (ordinates) are recorded from inside cells of the liver surface located at varying distances (abscissae) from the current source. Current source is at length zero. (a) Spatial decrement of the voltage in normal liver. o , Δ , Data obtained in two normal livers from animals of the same genetic strains as in *b*. (b) Spatial decrement of voltage in liver regions with normal histological appearance in the neighborhood of which the first cancer cell transplants (\blacktriangle , Novikoff; \bullet , Morris, No 7787) are growing. Current in (a) 1.7×10^{-7} A; in (b) 1.7×10^{-8} A.

cancer cells are, at least, three orders of magnitude smaller than in normal cells.¹ Moreover, the perijunctional insulation, r_s , appears to be weaker than in normal cells.

Effects of Communication in Normal Cells Induced by Invading Cancer Cells

Cancer cells induce changes in communication among normal cells. This became apparent early

¹ Normal liver cells are closely bound together by junctional complexes which Farquhar and Palade (8) termed zonulae occludentes (4). This structural complex is likely to be conterminous with the functional complex delimited by the elements *C* and *S* of Fig. 3 (cf. reference 12). For cancer cells, we have no structural information in this regard. The estimate of junctional membrane permeability rests on the assumption that the *C* areas of cancer and normal cells are of the same order of magnitude.

in our work in the course of systematic explorations of the electrical field around an intracellular current source. In the normal liver, the lines of equipotential, as determined by intracellular measurements of resistive voltage along smooth regions of the liver surface, were roughly circular and concentric around the current source (Fig. 6). In livers invaded by transplanted cancer cells, this pattern was markedly distorted. Along certain directions of the liver surface, resistive voltage decremented as in normal liver (space constants of voltage decrement to $1/e$, 100–125 μ), whereas along others, the decrement was much steeper (Figs. 6 and 7). Histopathological examination showed then, invariably, presence of cancer cells in the neighborhood of the region with subnormal communication, although the region itself appeared normal by histological standards.

This effect of induced cell uncoupling is seen

most clearly during the early stages of cancer invasion, at a time when the first cancer cells originating, for example, from a cancer cell suspension injected into the peritoneum are seen to attach and to grow on the normal liver. Around the cancer cells was then often found a fringe of cells normal by histological standards but with significantly smaller communication ratios (and higher input resistances) than normal cells; cells beyond the fringe presented normal communication. For instance, in an early phase of liver invasion by Morris' cancer cells No. 7793, the communication ratio in the fringe was 0.3, the space constant of potential decrement was 19μ , and the input resistance was $12 \times 10^5 \Omega$, all three values differing from normal values at a level of statistical significance better than 0.001.

The ability of inducing changes in communication was found in all transplanted cancers examined; in the fast growing ones, such as Novikoff's, as well as in the slowly growing ones, such as Morris' No. 7787. The values given above for the Morris' No. 7793 are quite typical for all.

This result immediately poses two questions. Do the induced changes in communication represent intermediate stages in the genesis of cancer, that is, intermediate stages in the transformation of normal into cancer cells? Does the phenomenon reflect a genetic or a purely somatic change? We have no answers as yet to these questions.

Distinctive Electrical Parameters of Cancer Cells

Table I summarizes some of the electrical parameters of cancer and normal liver cells. The po-

tential between cell interior and exterior at zero current (cell resting potential) in all types of cancer cells is quite similar to that in normal cells (28–30 mv). Where cancer cells differ strikingly from normal ones is in certain membrane permeability properties. Their communication ratio is several orders of magnitude lower, and their input resistance is 20 to 100 times greater than in normal cells (Table I). The differences are so marked that they offer a means for identifying cancer at the cellular level. The input resistance is a particularly convenient diagnostic index, since it is so easy to measure, especially with the single-electrode version of the methods (Fig. 1 *b*). The cell material used for electrical measurements was examined histologically, and it was very satisfying that there were no discrepancies between the histopathological diagnosis, kindly given to us by Dr. R. Lattes, and the electrical one.

Implications

In liver cells with cancerous growth the picture of the cell membrane surface which emerges from the present results is in striking contrast to that of cells with normal growth. In the normal liver cell system, the junctional membrane surfaces are freely permeable to small ions (20) and possibly also to large ions and molecules, as in other connected cell systems (11, 13, 22). In the cells with cancerous growth, the junctional membranes, if they exist at all as functional entities in these cells, are relatively impermeable even to the smaller ions. In this respect, the behavior of the cancer cells is similar to that of normal cells after their junctional membranes are sealed off by certain

TABLE I
Distinctive Parameters of Normal and Cancer Cells

Liver preparation	Communication ratio* V_{II}/V_I	Input resistance* $10^5 \Omega$	No. of cases
Normal	0.6 ± 0.01	2.57 ± 0.05	100
Primary cancer, azo-dye induced	<0.002	98	10
Transplanted cancers, Morris' No. 7787	<0.002	60 ± 7	24
Morris' No. 7793	<0.002	243 ± 16	29
Novikoff's	<0.002	88 ± 10	13

* Mean values with their standard errors. The differences in communication ratio and input resistance between normal and cancer liver cells are in all cases significant at a level better than 0.001.

uncoupling agents (12, 12 a, 15, 19, 21). Thus, while in the cell system with normal growth there seems to be ample room for possible growth-controlling substances to flow from one cell interior to another, there is virtually none in the systems with abnormal growth here.

The result bears on the question of control of tissue growth and differentiation in general, as well as on its more restricted aspect of cancerous growth. In respect to the first question, an interesting situation of contrast is provided by liver regenerating after surgical ablation. During such regeneration, multiplication of liver cells is as fast as or even faster than that in some of the aforementioned cancers. Yet, in this type of growth, which shapes a normal organ and which stops when a normal organ mass is attained, there is good cellular communication at all times (16).

As to the question of cancerous growth, junctional impermeability emerges from the present results as a possible factor in cancer etiology. One is now in the advantageous position of formulating etiological questions in terms of junctional membrane permeability; the first steps in this direction are just being made (12 b). A major question is now what place within the causal chain of cancer

is occupied by junctional communication. Before speculating in this direction, one would wish to know the range of generality of bad junctional communication in cancer and in other cell systems lacking "contact inhibition," especially since good electrical communication has just been shown to exist between certain mouse and hamster fibroblasts in tissue culture transformed by viruses (22). We are greatly indebted to Dr. R. Lattes, Columbia University, for histopathological examinations of our cell material, and to Dr. E. Hirschberg, Columbia University, Dr. S. Sorof, Institute of Cancer Research, Philadelphia, and Dr. J. Roth, University of Connecticut, for supplying us with the cancer material. We thank Mr. I. Baird, of our laboratory, for valuable assistance in the design and construction of the electronic equipment.

Dr. Kanno is a Visiting Fellow from the Physiology Department of Tokyo Medical and Dental University. His present address is Department of Physiology, Hiroshima University, Japan.

The work was supported in part by grants from the National Science Foundation and National Institutes of Health.

Received for publication 15 August 1966.

REFERENCES

1. ABERCROMBIE, M., and E. M. HEAYSMAN. 1954. Social behavior of cells in tissue culture. II. Monolayering of fibroblasts. *Exptl. Cell Res.* **6**: 293.
2. ABERCROMBIE, M., E. M. HEAYSMAN, and H. M. KARTHAUSER. 1957. Social behavior of cells in tissue culture. III. Mutual influence of sarcoma cells and fibroblasts. *Exptl. Cell Res.* **13**:276.
3. BAIRD, I., 1967. A new stimulus isolator for biological preparations. *Med. Electron. Biol. Eng.* In press.
4. BENEDETTI, E. L., and P. EMMELOT. 1965. Electron microscopic observations on negatively stained plasma membranes isolated from rat liver. *J. Cell Biol.* **26**:299.
5. BERWALD, Y., and L. SACHS. 1963. In vitro cell transformation with chemical carcinogens. *Nature.* **200**:1182.
6. DULBECCO, R. 1963. Transformation of cells in vitro by viruses. *Science.* **142**:932.
7. ENDERS, J. F. 1964. Cell transformation by viruses, as illustrated by the response of human and hamster renal cells to Simian virus 40. *Harvey Lectures (1962-1963)*. 113.
8. FARQUHAR, M. G., and G. E. PALADE. 1963. Junctional complexes in various epithelia. *J. Cell Biol.* **17**:375.
9. FURSHPAN, E. J., and D. D. POTTER. 1958. Transmission at the giant motor synapses of the crayfish. *J. Physiol.* **145**:289.
10. LASH, J. W. 1955. Studies on wound closure in Urodeles. *J. Exptl. Zool.* **128**:13.
11. KANNO, Y., and W. R. LOEWENSTEIN. 1967. Cell-to-cell passage of large molecules. *Nature.* **212** 629.
12. LOEWENSTEIN, W. R. 1966. Permeability of membrane junctions. In Conference on Biological Membranes: Recent Progress. *Ann. N. Y. Acad. Sci.* **137**:441.
- 12 a. LOEWENSTEIN, W. R. 1964. Surface membranes in close contact. Role of Calcium and Magnesium ions. *J. Colloid Interface Sci.* In press.
- 12 b. LOEWENSTEIN, W. R. 1967. Some reflections on growth and differentiation. *Perspect. Biol. Med.* In press.
13. LOEWENSTEIN, W. R., and Y. KANNO. 1964. Studies on an epithelial (gland) cell junction. I. Modifications of surface membrane permeability. *J. Cell Biol.* **22**:565.

14. LOEWENSTEIN, W. R., and Y. KANNO. 1966. Intercellular communication and the control of tissue growth. Lack of communication between cancer cells. *Nature*. **209**:1248.
15. LOEWENSTEIN, W. R., M. NAKAS, and S. J. SOCOLAR. 1967. Junctional membrane uncoupling: Permeability transformations at a cell membrane junction. *J. Gen. Physiol.* In press.
16. LOEWENSTEIN, W. R., and R. D. PENN. 1967. Intercellular communication and tissue growth. II. Tissue regeneration. *J. Cell Biol.* **33**:235.
17. LOEWENSTEIN, W. R., S. J. SOCOLAR, S. HIGASHINO, Y. KANNO, and N. DAVIDSON. Intercellular communication: renal, urinary bladder, sensory, and salivary gland cells. *Science*. **149**:295.
18. MILLER, E. C., T. A. MILLER, B. E. KLINE, and H. P. RUSH. 1948. Correlation of the level of Riboflavin with the appearance of liver tumors in rats fed aminoazo dyes. *J. Exptl. Med.* **88**:89.
19. NAKAS, M., S. HIGASHINO, and W. R. LOEWENSTEIN. 1966. Uncoupling of an epithelial cell membrane junction by calcium-ion removal. *Science*. **151**:89.
20. PENN, R. D. 1966. Ionic communication between liver cells. *J. Cell Biol.* **29**:171.
21. PENN, R. D., and W. R. LOEWENSTEIN. 1966. Uncoupling of a nerve cell membrane junction by calcium-ion removal. *Science*. **151**:88.
22. POTTER, D. D., E. J. FURSHPAN, and E. S. LENNOX. 1966. Connections between cells of the developing squid as revealed by electrophysiological methods. *Proc. Natl. Acad. Sci. U. S. A.* **55**:328
23. RUBIN, H. 1961. Influence of tumor virus infection on the autogeneity and behavior of cells. *Cancer Res.* **21**:1244
- 23 a. STOKER, M. 1963. Neoplastic transformation by polyoma virus and its wider implications. *Brit. Med. J.* **1**:1305.
24. WEISS, P. 1958. Cell contact. *Intern. Rev. Cytol.* **7**:391.