



Since January 2020 Elsevier has created a COVID-19 resource centre with free information in English and Mandarin on the novel coronavirus COVID-19. The COVID-19 resource centre is hosted on Elsevier Connect, the company's public news and information website.

Elsevier hereby grants permission to make all its COVID-19-related research that is available on the COVID-19 resource centre - including this research content - immediately available in PubMed Central and other publicly funded repositories, such as the WHO COVID database with rights for unrestricted research re-use and analyses in any form or by any means with acknowledgement of the original source. These permissions are granted for free by Elsevier for as long as the COVID-19 resource centre remains active.

# Dengue Virus

---

*Amudhan Murugesan and Mythreyee Manoharan*

Department of Microbiology, Government Theni Medical College, Theni, India

---

## ABBREVIATIONS

---

|                  |                                  |
|------------------|----------------------------------|
| <b>ADE</b>       | antibody-dependent enhancement   |
| <b>cDNA</b>      | complementary DNA                |
| <b>CM</b>        | convoluted membrane              |
| <b>CS</b>        | complementary sequence           |
| <b>DALYs</b>     | disability-adjusted life years   |
| <b>DENV</b>      | dengue virus                     |
| <b>DF</b>        | dengue fever                     |
| <b>DHF</b>       | dengue hemorrhagic fever         |
| <b>dsRNA</b>     | double-stranded RNA              |
| <b>DSS</b>       | dengue shock syndrome            |
| <b>E protein</b> | envelope protein                 |
| <b>ER</b>        | endoplasmic reticulum            |
| <b>GWAS</b>      | genome-wide association studies  |
| <b>HI</b>        | hemagglutination inhibition      |
| <b>HLA</b>       | human leukocyte antigen          |
| <b>MBFV</b>      | mosquito-borne flaviviruses      |
| <b>NS</b>        | nonstructural                    |
| <b>NTPase</b>    | nucleoside triphosphatase        |
| <b>ORF</b>       | open reading frame               |
| <b>RC</b>        | replication complex              |
| <b>RdRp</b>      | RNA-dependent RNA polymerase     |
| <b>RNA</b>       | ribonucleic acid                 |
| <b>RTPase</b>    | RNA nucleoside 5' triphosphatase |
| <b>SSL</b>       | side stem loop                   |
| <b>TBFV</b>      | Tick-Borne Flaviviruses          |
| <b>TGF</b>       | tumor growth factor              |
| <b>TNF</b>       | tumor necrosis factor            |
| <b>UAR</b>       | upstream AUG region              |
| <b>UTR</b>       | untranslated region              |
| <b>VPs</b>       | vesicle packets                  |

---

## INTRODUCTION

---

Dengue viruses (DENVs) form dengue complex in genus *Flavivirus*, family Flaviviridae, and consists of four antigenically related but distinct DENV serotypes (DENV-1, DENV-2, DENV-2, DENV-3, and DENV-4). These DENV can cause a spectrum of illness ranging from asymptomatic dengue infection to dengue fever (DF) to dengue hemorrhagic fever (DHF) to dengue shock syndrome (DSS). It is estimated that close to 3.6 billion are at risk with 390 million infections of which 96 million are symptomatic. Among the 96 million symptomatic cases, 2 million end in severe form of infections, that is, DHF and DSS, and around 21,000 fatal cases occur annually around the world. Most of these infections occur in the developing and underdeveloped countries where the surveillance network for infectious diseases are not robust which means there is a possibility of gross underreporting of dengue. In this chapter we will discuss the evolution of virus and its vector, epidemiology of dengue, molecular and genomic structure of DENV, their pathogenesis, immune response of the host to the infection, laboratory diagnosis, management, and recent developments in dengue drug and vaccine development.

---

## EVOLUTION AND DISCOVERY OF DENGUE VIRUS

---

All four DENV original serotypes have similar natural histories, including an enzootic cycle involving nonhuman primates and canopy-dwelling mosquitoes in Asia, and an urban cycle involving humans as the primary vertebrate host and *Aedes* mosquitoes of the subgenus *Stegomyia* as the primary mosquito vectors globally in the tropics. Some authors speculated an African origin and subsequent distribution around the world with the slave trade (Ehrenkranz et al., 1971; Smith, 1956a). It has also been proposed that the viruses may have originated in a forest cycle involving lower primates and canopy-dwelling mosquitoes in the Malay Peninsula (Halstead, 1992; Smith, 1956a). Recent studies based on sequence data of dengue and other flaviviruses have suggested an African origin of the progenitor flavivirus, which ultimately branched into three genera, *Flavivirus*, *Pestivirus*, and *Hepacivirus*.

The DENVs belong to the genus *Flavivirus*, which branched into four subgroups: (1) the insect-specific viruses that have only been isolated from various mosquito species; (2) the vertebrate viruses that have no known arthropod vector, and which have been isolated only from rodents and bats; (3) the mosquito-borne viruses; and (4) the tick-borne

viruses (Cook et al., 2012; Crabtree et al., 2005; Kuno et al., 1998; Uzcategui et al., 2003). It seems plausible that the ancestral flavivirus was a mosquito or tick virus that diverged by adapting to a variety of vertebrate hosts, including rodents, birds, bats, and nonhuman primates.

That the tick-borne and mosquito-borne viruses had a common ancestor is supported by the fact that several mosquito-borne flaviviruses (MBFV) [Koutango, Saboya, West Nile, and yellow fever (YF)] have all been isolated from ticks (Attoui et al., 2000). Also, it has been reported that some tick-borne viruses replicate in mosquitoes or mosquito cell cultures (Clifford et al., 1971). It is not known whether the divergence of the four *Flavivirus* subgroups occurred in Africa, in Asia, or in both areas.

The Asian origin of DENVs is supported by both ecological and phylogenetic evidence (Vasilakis et al., 2008). Thus all four dengue serotypes have been documented in a sylvatic cycle involving nonhuman primates and arboreal mosquitoes in the Malay Peninsula (Marchette et al., 1978), whereas only DENV-2 has been documented in a similar cycle in Africa (Robert et al., 1993).

These data collectively suggest that the DENVs most likely evolved as viruses of mosquitoes before becoming adapted to lower primates and then to humans, an estimated 1500–2000 years ago (Moncayo et al., 2004; Wang et al., 2000a). DENVs are highly adapted to their mosquito hosts, being maintained by vertical transmission in mosquito species responsible for sylvatic cycles, with periodic amplification in lower primates.

Hotta and Kimura were the first to isolate the virus in 1943, by intracranial inoculation of serum from an acutely ill patient into suckling mice (Hotta, 1952, 1953). Sabin et al. similarly isolated viruses from US soldiers stationed in India, New Guinea, and Hawaii in 1944 (Sabin and Schlesinger, 1945). Some virus strains from all three geographic locations were antigenically similar. This virus was called dengue 1. Several isolates of another antigenically distinct virus strain from New Guinea were called dengue 2.

Two more serotypes, dengue 3 and dengue 4, were subsequently isolated from patients with a hemorrhagic disease during an epidemic in Manila, the Philippines, in 1956 (Hammon et al., 1960b). The recent isolate from Malaysia, however, may increase the dengue complex to five serotypes (Normile, 2013).

## EVOLUTION AND SPREAD OF DENGUE VIRUS VECTOR

---

*Aedes aegypti* is most likely of African origin for the following reasons. First, there are no closely related *Stegomyia* species in the Americas, whereas there are numerous such species of the same subgenus in both

the Ethiopian and Oriental regions. Second, *A. aegypti* occurs in Africa as a widespread feral species, breeding in the forest, independent of humans. It is primarily an urban species in both of these regions and only rarely occurs in the absence of man. Current thinking is that *A. aegypti* had an African origin and had adapted to the peridomestic environment, breeding in water storage containers in West African villages prior to the slave trade, which provided the mechanism for the species to be introduced to the New World. By 1800, *A. aegypti* had already become established in many large tropical cities around the world, especially in port cities in Asia and the New World. *A. aegypti* did not become the predominant *Stegomyia* species in many noncoastal cities until during and after the Second World War (Smith, 1956b).

It is clear that the species is very strictly limited by latitude and rarely persists for any time beyond 45°N and 35°S. In the 18th and 19th centuries, *A. aegypti* commonly expanded its geographic distribution to more northern and southern latitudes during the warm summer months, breeding in stored water containers aboard river boats, ships, and other means of transportation, ultimately infesting northern cities in North America and Europe and frequently transmitting epidemic dengue and YF (Kuno, 2012).

During the winter months, the species would disappear from areas above and below the January and July isotherms of 10°C in the northern and southern latitudes, respectively. Secondary mosquito vectors of human infections include *Aedes albopictus*, which was most likely the original epidemic vector of DENVs (Smith, 1956a). An Asian mosquito, it was the predominant day-biting *Stegomyia* species in Asian villages and cities until the Second World War. DENVs are transmitted in sylvatic cycles in Asia and Africa. The principal sylvatic cycle occurs in the Malay Peninsula, where all four serotypes are transmitted to nonhuman primates by species of the *Aedes (Finlaya) niveus* complex (Marchette et al., 1978).

## Evolution and Spread of Vector

At some point in the past 2000–4000 years, DENVs moved out of the Asian jungle and into rural villages, where they were, and still are, transmitted to humans by peridomestic mosquitoes such as *A. albopictus*. Migration of people and commerce ultimately moved the viruses into larger villages, towns, and cities of tropical Asia, where the viruses were most likely transmitted sporadically by *A. albopictus* and possibly other closely related peridomestic *Stegomyia* species (Halstead, 2007). The slave trade and the resulting commerce were responsible for the introduction and the widespread distribution of an African mosquito,

*A. aegypti*, into the New World, most likely during the 17th century. This species became highly adapted to humans and the urban environment, and was ultimately spread throughout the tropics by the shipping industry. The species most likely first infested port cities and then moved inland as urbanization expanded (Gubler, 2012).

First reports of major epidemics of an illness compatible with and thought possibly to be dengue was published during the Jin Dynasty (CE 265-420), this encyclopedia was formally edited in CE 610 (Sui Dynasty) and again in CE 992 during the Northern Sung Dynasty. The disease was called “water poison” by the Chinese and was thought to be somehow connected with flying insects associated with water (Gubler, 2014).

It is uncertain that the epidemics in Batavia (Jakarta), Indonesia, and Cairo, Egypt, in 1779 were dengue. Serologic studies have identified DENV-1 as the predominant virus in the Philippines and Greece in the 1920s and in the South Pacific in the 1930s (Halstead and Papaevangelou, 1980; Simmons, 1931; Rosen, 1986). It was this serotype that also caused the major regional epidemic that occurred in the Pacific and Asia during the Second World War (Hotta, 1953; Kuno, 2009; Sabin and Schlesinger, 1945).

A particular virus serotype persisted in some geographic regions for several years, emerging periodically to cause epidemics, as herd immunity in the human population waned, and as new epidemic strains of virus emerged. This is supported by recent studies that have shown that a single serotype and genotype have remained dominant in a country causing periodic epidemics for as long as 20 years (Gubler, 2014). It has also been documented that some virus subtypes persist in urban communities with “silent” transmission, causing mild nonspecific febrile illness not recognized as dengue (Gubler et al., 1978; Yoon et al., 2012).

The most likely origin of the word dengue is from Swahili. In both the 1823 and 1870 epidemics of dengue-like illness in Zanzibar and the East African coast the disease was called Ki-Dinga pepo, which meant “a disease characterized by a sudden cramp-like seizure, caused by an evil spirit.” During the 1828 epidemic in Cuba, the illness was first called Dunga but was later called dengue, the name by which it has been known ever since (Gubler, 2014).

## Mosquito Transmission of Dengue Viruses

With documentation that YF was transmitted by mosquitoes (Reed et al., 1900), many early workers suspected that DF was also a mosquito-borne disease. It was the first documentation that mosquitoes could transmit DF (Graham, 1903). This work was followed, which

showed conclusively that *A. aegypti* could transmit the disease to volunteers following a 10-day incubation period after the mosquitoes had fed on a person acutely ill with DF.

## Factors Responsible for the Global Resurgence of Dengue

Disease such as dengue was not considered a major public health problem in the first place, and this led to policy changes, a redirection of resources and decay in the public health infrastructure to deal with infectious disease in general and vector-borne diseases in particular (Gubler, 1989b, 1994, 1998b, 2001). In addition to the lack of political will, successful mosquito control programs were replaced by emergency response programs that relied on high-technology outdoor space spraying with nonresidual insecticides. Although very popular politically, these programs were never effective in interrupting transmission because they were usually initiated too late and in geographically limited areas. Moreover, the insecticide did not reach its targets, the adult *A. aegypti*, which were resting in secluded places inside houses (Gubler, 2011).

The failure to control the mosquito vectors of dengue unfortunately coincided with a period of dramatic urban growth, globalization, and changing lifestyles. Contributing to the problem were water storage practices in the cities where water supplies were unreliable, the use of nonbiodegradable containers for packaging consumer goods, and the rapidly growing automobile industry. Water storage containers such as plastics and used automobile and truck tyres provided ideal oviposition sites and larval habitats for *A. aegypti* mosquitoes (Gubler, 1994). Most mosquito control efforts since the early 1970s were directed toward adult mosquitoes using expensive methods that were ineffective, while changing lifestyles were providing increasingly more larval habitats. The result was large mosquito populations and crowded human populations living in intimate contact with each other and increased dengue transmission. Urban growth has been dramatic since the early 1960s, driven primarily by economic expansion, the cities of tropical developing countries exploded, with millions of susceptible people migrating from rural areas (Gubler, 2011).

In 1999 global urban population was estimated to be 5 billion people and currently the population has crossed 7.6 billion; it is projected that 6.3 billion people will live in urban areas. Economic growth has also been the principal driver of globalization. Intercontinental travel now poses a major risk for pandemic spread of pathogens, as illustrated by the recent spread of dengue, influenza, and severe acute respiratory syndrome (SARS)-coronaviruses (Gubler, 2011). In this era, major cities of the tropical world have crowded human populations, no effective

mosquito control, and are hyperendemic, with multiple DENV serotypes cocirculating. The DENVs have fully adapted to humans, no longer requiring the sylvatic cycles for survival (Gubler, 1998a). The large crowded tropical cities of the world, all of which have modern airports, provide the perfect environment for the maintenance, propagation, and spread of dengue and other *A. aegypti*-transmitted diseases.

DF/DHF is the most important arboviral disease of humans occurring in all major tropical areas of the world, with over 3.6 billion people living in areas at risk for infection. An estimated 390 million infections and 96 million symptomatic cases of dengue, including more than 2 million cases of DHF and 15,000 deaths (range: 6100–24,300), occur annually (Bhatt et al., 2013). The case-fatality rate of DHF averages ~5%; World Health Organization estimates more than 20,000 deaths each year (Bhattacharya et al., 2013). The estimated lifetime number of infections per person in Southeast Asia was estimated at 3.3, with an overall annual infection rate of 5% (12.5% annual infection rate among children under 15 and 2.8% among adults).

The current global pandemic of DF/DHF began in the Asia during the Second World War, when both the viruses and the mosquito vector, *A. aegypti*, were spread widely throughout the regions (Halstead, 1992). During the war, existing water systems were destroyed, and water was stored for domestic use as well as for fire control. Military equipment and junk were left behind, making ideal larval habitats for *A. aegypti*. The movement of equipment and other war activities resulted in the transport of mosquitoes and their eggs to new geographic areas (Guzman et al., 2010). The result was a greatly expanded geographic distribution and increased densities of *A. aegypti* and increased epidemic dengue activity (Bhatia et al., 2013). The economic expansion was the driving force of unprecedented urban growth that continues today (Ferreira, 2012). Housing, water, sewer, and waste management were inadequate. The vector population thus increased dramatically in the crowded, unhygienic cities of Asia, as mosquito control measures was not effective. The economic expansion also led to increased movement of people (along with them the viruses also moved among cities and countries in the region). Those countries that did not already have hyperendemic rapidly became hyperendemic (Gubler, 2011).

The first recorded epidemic occurred in Manila, the Philippines, in 1953/54, followed by another in 1956 (also in Manila) and a third epidemic in Bangkok in 1958 (Hammon et al., 1960a). During the 1960s and 1970s the disease caused outbreaks in India, Malaysia, Singapore, Vietnam, Indonesia, and Myanmar. From the 1970s to the present time, there has been a dramatic geographic expansion of epidemic DHF in



the countries of Asia and from there to the Pacific and the Americas (Bhatia et al., 2013). Japan routinely experienced dengue epidemics in its southern islands of Okinawa and Formosa (Taiwan), but the Japanese mainland was not affected until the Second World War (Hotta, 1953). Following the Second World War, the isolation of the Pacific resulted in the disappearance of DENVs from the area for 20 years. In the late 1971, explosive epidemics of DF were caused by DENV-2 (Moreau et al., 1973). In 1974 DENV-1 was reintroduced into the Pacific from Asia and rapidly spread throughout the islands in a pattern similar to that of DENV-2 (Kuberski et al., 1977). DENV-4 (1979) and DENV-3 (1980) were also introduced from Asia and spread in a similar fashion.

The first reports of DF in Australia were in the late 1800s and, from 1880 to 1955. Although *A. aegypti* was probably never eradicated from Northern Queensland, a combination of improved water systems and control programs reduced the populations to very low levels during the 1960s and 1970s, when dengue transmission was not reported. After an absence of 26 years, dengue reappeared in Northern Queensland in 1981/82 with DENV-1 causing an outbreak in several cities (Kay et al., 1984). In the Americas, from 1946 to 1963, there was no evidence of dengue epidemic, and this quiescence was due to several factors, but of importance was the *A. aegypti* eradication program by Pan America Health Organization which was aimed at reducing the YF outbreaks (Gubler, 2014). The eradication program was discontinued in the early 1970s because urban epidemics of dengue and YF were no longer a problem. Failure to eradicate *A. aegypti* from the whole region, however, resulted in repeated reinvasions by this mosquito into those countries that had achieved eradication. During the 1970s, support for mosquito surveillance and control programs waned, and by the end of the decade, many countries had been reinfested with *A. aegypti* (Gubler, 1989a). In 2012 *A. aegypti* had a distribution similar to that in the 1940s, before eradication was initiated; only Bermuda and Chile remain free of this mosquito. A characteristic of dengue in the Americas from 1963 through the early 1980s was hypoendemicity, that is, only a single serotype was present at any one time in most countries (Gubler, 1989b). Thus reinvasion of Central and South America by *A. aegypti* in the 1970s and 1980s, combined with increased urbanization and movement of people, and with them DENVs and mosquito vectors, which spread via commerce, resulted in most countries evolving from nonendemicity (no viruses present) or hypoendemicity (one virus present) to hyperendemicity (multiple virus serotypes present) (Rigau-Pérez et al., 1998).

Surveillance for dengue in Africa was exceptionally poor during the 20th century, and endemic transmission of DENV-1 and DENV-2 was documented in Nigeria. Reports of epidemic DF have increased dramatically since 1980. Outbreaks have occurred in both East and West Africa (Amarasinghe et al., 2011; Were, 2012).

To summarize, the current dengue pandemic was originated in Southeast Asia following the Second World War. During the postwar years, when the DHF syndrome was first described, the severe disease was sporadic and localized in a few Southeast Asian countries. In the 1970s, however, the disease began to spread, first within Asia and then to the Pacific and tropical America. Due to factors such as lack of political will, successful mosquito control programs were replaced by emergency response programs that relied on high-technology outdoor space spraying with nonresidual insecticides. Although very popular politically, these programs were never effective in interrupting transmission, because they were usually initiated too late, and in geographically limited areas. Moreover, the insecticide did not reach its targets, the adult *A. aegypti*, which were resting in secluded places inside houses (Gubler, 2011; Murray et al., 2013).

The failure to control the mosquito vectors of dengue unfortunately coincided with a period of dramatic urban growth, globalization, and changing lifestyles. Contributing to the problem were water storage practices in the cities where water supplies were unreliable, the use of nonbiodegradable containers for packaging consumer goods, and the rapidly growing automobile industry. Water storage containers such as plastics and used automobile and truck tyres provided ideal oviposition sites and larval habitats for *A. aegypti* mosquitoes. Most mosquito control efforts since the early 1970s were directed toward adult mosquitoes using expensive methods that were ineffective, while changing lifestyles were providing increasingly more larval habitats. The result was large mosquito populations and crowded human populations living in intimate contact with each other, and increased dengue transmission (Banerjee et al., 2015) (Fig. 16.1).

## ECONOMIC BURDEN

---

Dengue represents a substantial economic and disease burden to communities and health systems in endemic countries, with a 30-fold increase in reported cases since the early 1960s. Factors that contribute to the increased incidence of dengue include the following: a rise in global commerce and tourism, population growth and rapid urbanization, inadequate water, sewer, and waste management systems, and inadequate vector control policies (Shepard et al., 2014). The expansion

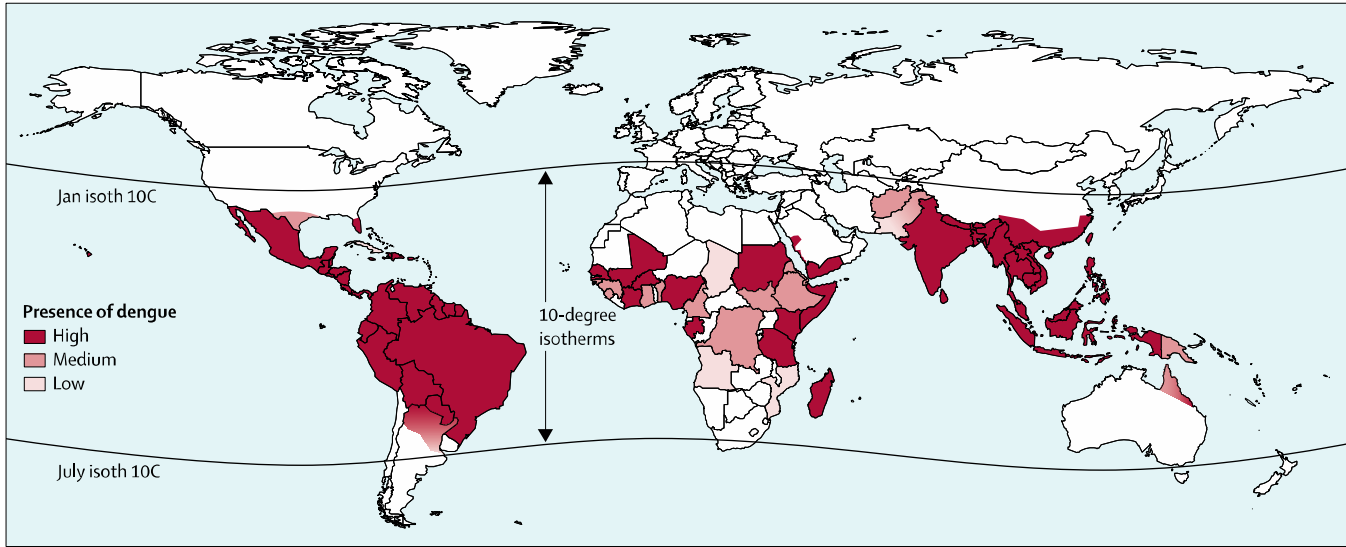

**FIGURE 16.1** Global dengue burden. Source: Adapted from Bhatt, S., Gething, P.W., Brady, O.J., Messina, J.P., Farlow, A.W., Moyes, C.L., et al., 2013. The global distribution and burden of dengue. *Nature* 496 (7446), 504507. Available from: <https://doi.org/10.1038/nature12060>.

of dengue poses a serious economic and disease burden in more than 100 countries across the world. Economic burden estimation of dengue is critical to provide policymakers, researchers, developers, and drug and vaccine manufacturers, and donors with reliable and comparable measures to inform decisions about health policy, research, and health service priorities. Disease burden refers to the impact of a disease on mortality and morbidity in a population and is represented by disability-adjusted life years (DALYs), a nonmonetary index that estimates a person's years of life lost due to premature mortality.

The economic burden of dengue has three main components: (1) illness costs are costs directly related to the disease; (2) surveillance and control costs are costs related to dengue surveillance, vector control, and other preventive activities; and (3) other costs, which are harder to measure, encompass the effects of seasonal clustering of dengue on health systems, decreases in tourism during dengue outbreaks (Shepard et al., 2014) or comorbidities and complications associated with dengue infection (Davis and Bourke, 2004; Laoprasopwattana et al., 2010; Seet et al., 2007a; Wills et al., 2009) The economic cost of dengue can be estimated as the total number of dengue episodes times the unit costs per episode.

Surveillance systems in most countries are passive, that is, they are dependent on the case presenting to the healthcare system. While passive surveillance systems are adequate for monitoring general trends in dengue infections and promptly detecting dengue outbreaks, they usually underreport the total episodes of symptomatic dengue. Common limitations of passive surveillance systems include variations in the definitions of reportable dengue, misdiagnosis of dengue episodes, unrecognized dengue symptoms, misinterpretation of diagnostic tests, reliance on reports by healthcare professionals and laboratory staff, limited surveillance budgets, and variability in reporting rates between inpatient and outpatient settings, public or private facilities, or between epidemic and nonepidemic cycles (Beatty et al., 2010; Gubler, 2002; Kuno, 2007; Siqueira et al., 2004a).

Direct unit costs include direct medical costs such as diagnostic tests, drugs and medications, and medical personnel salaries and fringe benefits. Nonmedical costs include costs such as transport, lodging, or food. The main source of indirect costs of dengue is work-time loss (i.e., productivity loss) caused by disability and, in some cases, death. The resources and time spent by the patients' caregivers are also included in the nonmedical direct and indirect unit costs of dengue (Shepard et al., 2014).

Unfortunately, there are only a few studies that estimate the economic and disease burden of dengue by region. There are areas of uncertainty in measuring the economic loss associated with dengue.

First, estimating the total episodes of dengue is difficult due to paucity of data. Second, there is some evidence suggesting that the rate of underreporting varies by the severity of dengue, with better reporting for more severe cases of dengue (Duarte and Franca, 2006). Third, most estimates of the economic cost of dengue only include the febrile (1–7 days) and subsequent critical phase of dengue, totaling ~12 days (Lum et al., 2008; Suaya et al., 2009). But dengue leads to substantial reduction in the patients' quality of life during and after the febrile period. Last, there is considerable uncertainty in the burden of dengue in large parts of the world, including the Western Pacific, South Asia, and Africa. While there have been several reports of dengue outbreaks occurring in these regions, many countries do not have surveillance systems to monitor and report dengue episodes, or lack accurate identification methods. Another area of uncertainty includes population's health-seeking behavior and the multiplicity of sites for treatment with privately treated patients having modest rate of reporting and near nil reporting from patients seeking alternate method of treatment such as pharmacy or traditional medicine (Suaya et al., 2009).

Currently, there is no effective dengue vaccine or specific antiviral treatment for dengue. The only way to prevent and control the spread of dengue infection is to suppress the vector population through an active vector control system, based on a strong and active surveillance system (Gubler and Clark, 1995). Surveillance and early detection of dengue cases are the first line of defense against potential epidemic. They guide health agencies response, optimize the use of scarce resources by focusing on infected areas, and generate invaluable information for both health providers and policymakers (Guzman et al., 2010). The cost of dengue vector control and surveillance encompasses the following: cost of surveillance, clean-up campaigns, fumigation, inspection, and education of general public.

Traditional dengue control strategies focus on reducing mosquito abundance, reducing adult mosquitoes life span, and preventing mosquito–human contact through: (1) source reduction (locating and destruction of mosquito breeding sites); (2) use of larvicides to control juvenile mosquitoes (life stages that occur in water); and (3) use of ultra-volume aerosolized adulticides to control adult mosquitoes (Baly et al., 2012; Massad and Coutinho, 2011). However, integrated vector management is the recommended strategy for all vector-borne diseases, including dengue. This strategy involves social mobilization, environmental management, epidemiological and entomological surveillance, and chemical and biological control (Tapia-Conyer et al., 2012a). However, due to budget constraints and competing priorities, effective mosquito control is weak in most dengue-endemic countries (Tapia-Conyer et al., 2012b), resulting in a “crisis mentality” focusing on implementing emergency control methods in response to epidemics (Gubler, 2002).

Vector control is currently the only intervention against dengue. However, ineffective vector control programs allowed the spread of *Aedes* mosquito species and with it dengue illness. Community-based dengue control programs alone or in combination with other control activities can enhance the effectiveness of dengue control programs (Heintze et al., 2007). In addition, insecticide resistance is a challenge that can lead to failure of dengue control programs and complicates the control activities further by increasing the magnitude of future dengue epidemics. Economic analysis of other dengue control technologies under development, such as genetics-based sterile insect methods, infection of mosquitoes with *Wolbachia*, and vaccination, are important to guide investment for these technologies, policy formulation, adaptation, and adoption of these technologies, and thereby mitigate the economic and burden of dengue illness in the future (Luz et al., 2011).

Another technology that might prove to be more effective is a human dengue vaccine. Immunization was the most cost-effective at US\$2435 per DALY averted, compared to US\$3368 per DALY averted for vector control of adult *A. aegypti*, and US\$6883 per DALY for immunization, case management, and environmental control—all costs (Shepard et al., 2004). This analysis concluded that vaccination, when available, will be the most cost-effective policy. In addition, it is much more favorable than the US\$3368 per DALY saved from environmental management (Zeng et al., 2018). The incremental cost-effectiveness ratio for a dengue vaccine in Southeast Asia, estimated at US\$62.47 per DALY saved (in 2011 US\$), is comparable to most favorable public health programs for children, which cost on average <US\$100 per DALY saved (in 2011 US\$) (Shepard et al., 2012). The economic burden of dengue in the absence of any effective vaccine for the cohort was US\$123.70 per 1000 population per year, of which 67% is due to DHF. The situation with the highest incidence of DHF and lower vaccine price in the public sector makes the vaccine the most cost-effective (Shepard et al., 2004).

A drug that would help reduce symptoms and possible mortality would be a valuable and complementary tool for reducing the health and economic burden of dengue. Researchers have been testing several antiviral drugs. While the latest published results—like earlier ones—have proved disappointing, there have been notable advances in recent years. Although the need for such therapeutic agents would be reduced if effective preventive measures (vaccination and vector control) are developed and implemented, the remaining need and demand are still substantial. This quantification of the economic burden will contribute toward better decisions about the current, and promising new preventive and curative approaches to reduce the burden of dengue (Shepard et al., 2014).

## TAXONOMY AND EVOLUTIONARY RELATIONSHIP OF DENGUE WITH OTHER FLAVIVIRUSES

The flaviviruses form a well-defined genus based on shared antigenic and genetic properties. Many flaviviruses are important human pathogens, and most of these are zoonotic; in addition to dengue (DENV), the genus contains YF virus (YFV), Japanese encephalitis virus, West Nile virus (WNV), and tick-borne encephalitis viruses. The *Flavivirus* genus is classified in the family Flaviviridae, which it shares with two other recognized genera, *Pestivirus* and *Hepacivirus*, and a newly proposed genus consisting of G Barker Virus (GBV) isolates. The family is defined by similar morphology, genome organization, and replication, although each genus is distinct in antigenic and other biological properties. The genus *Flavivirus* is officially divided by the International Committee on Taxonomy of Viruses (ICTV) into 14 serogroups, consisting of 53 formally recognized species but up to 74 reported viruses (Adams et al., 2017; Wylie et al., 2017). For example, the dengue serotypes 1–4 are considered a single species even though they are genetically and antigenically quite distinct, because they have similar geographic distributions, host/vector associations, and disease syndromes.

### GENUS-LEVEL MORPHOLOGICAL AND GENOMIC PROPERTIES

All the Flaviviridae are spherical enveloped viruses with single-protein capsids, two to three membrane proteins (two in the flaviviruses, envelope and membrane), and single-stranded positive-sense ribonucleic acid (RNA) genomes lacking poly A tails at the 3' end. The Flaviviridae genome has single open reading frame (ORF) which is translated single complete polyprotein, with RNA helicase and RNA-dependent RNA polymerase (RdRp). The ORF is flanked by two noncoding regions. The flavivirus genome is ~11 kb in length. The coding region of flaviviruses includes, in the following order of three structural genes encoding for the proteins capsid (C), precursor membrane (prM, cleaved to membrane protein M during maturation) and envelope (E), and seven nonstructural (NS) genes encoding for NS1, NS2A, NS2B, NS3, NS4A, NS4B, and NS5. NS2B and NS3 form the protease, and NS3 also has helicase and RNA triphosphatase activity; NS5 is the RdRp and also has methyltransferase activity (Bennett, 2014).

Flavivirus genomic RNA serves as the only viral messenger RNA. Translation of the complete polyprotein begins at the first or a second AUG codon of the ORF. The polyprotein is cleaved at conserved sites



by either the viral serine protease (NS2B/NS3), a host-derived signalase, except for pr/M, which is cleaved after assembly by host-derived furin or a furin-like protease.

## REPLICATION STRATEGY OF FLAVIVIRUS

Flavivirus replication ensues in the cytoplasm on host endoplasmic reticular (ER) membranes that are modified into vesicular packets where replication probably occurs. Full-length complementary negative-sense RNA strands are produced that serve as templates for the positive-sense genome copies. Flavivirus assembly into virus particles probably occurs on the rough ER (RER), where they acquire their membranes. Virus particles mature as they pass through the host secretory system and exocytosis pathway by the cleavage of prM to M, eventually budding off the host cell. Interestingly, virions may be released that are coated with a mixture of both mature (cleaved) and immature (uncleaved) M/prM proteins.

Flaviviruses are defined by their antigenic relatedness, among other things, and all exhibit various degrees of cross-reactivity profiles in serological tests (Mansfield et al., 2011). Flaviviruses were first grouped together as Group B arboviruses based on cross-species hemagglutination inhibition (HI) and later divided into eight serocomplexes comprised of 49 viruses on the basis of cross-neutralization tests (Calisher et al., 1989). Serocomplexes correspond to amino acid distances over the E protein. Serocomplexes themselves exhibit varying degrees of antigenic similarity.

Phylogenetic structure across the highly ecologically diverse flaviviruses based on the entire coding region reflects the antigenic groups as well as host and/or vector associations. Three main clades emerge from the flaviviruses recognized by the ICTV the MBFV, the tick-borne flaviviruses (TBFV), and those restricted to vertebrate hosts or with no known vector (NKV). The most divergent taxon represented in the phylogeny of the flaviviruses is another candidate flavivirus, Tamana bat virus (Adams et al., 2017).

Most flaviviruses are zoonotic, transmitted to humans from animals via vectors such as ticks or mosquitoes, suggesting that they retain the evolutionary capacity to host-switch in spite of phylogenetic patterns (Mackenzie and Williams, 2009). Genome observations for the different flaviviral groups further support host- and/or vector-specific adaptations. Within the TBFV, viruses cluster according to antigenic groups and host associations, which are tightly correlated. Associated more closely with the TBFV than the MBFV is the lineage of flaviviruses restricted to vertebrates or with NKV. Within the MBFV, viruses are



phylogenetically subdivided largely in keeping with their antigenic groups.

Within the dengue serocomplex of currently described serotypes 1–4, the E protein consists of conserved and variable regions, with up to 37% amino acid divergence (Heinz and Stiasny, 2012). The presence of conserved regions accounts for the brief (in the order of months) cross-protection between serotypes (Sabin, 1952) and the diminishing and/or weakly neutralizing cross-reactive antibodies that contribute to severe disease in dengue through antibody-dependent enhancement (ADE) of infection (Bashyam et al., 2006; Halstead and Simasthien, 1970; Mady et al., 1991). In the end, the degree of variability in the E protein and resulting serological distinctiveness among dengue serotypes means there is no cross-protection for second, third, or fourth infections, although clinical illness is mild in third and fourth infections (Halstead et al., 1973a,b,c,d; Halstead and Palumbo, 1973).

The E protein is the primary target for neutralizing antibody formation due to its critical role in host cell receptor-mediated endocytosis and fusion. Epitopes have been mapped to all three of the E protein domains, I, II, and III: domain II near the fusion loop and the lateral ridge of domain III are both important neutralization targets (Ansaiah-Sobrinho et al., 2008; de Alwis et al., 2011; Wahala and Silva, 2011).

## MOLECULAR ARCHITECTURE OF DENGUE VIRUS

In recent years a great deal of research on DENV biology has provided an enormous amount of information about molecular aspects of its replication. Studies on molecular virology of viruses have been made possible by the use of full-length complementary DNA (cDNA) clones, genomic RNA with reporter genes and replicons. Full-length cDNA clones of four serotypes of dengue have been constructed and is being used to study their molecular biology (Kapoor et al., 1995; Kinney et al., 1997; Lai et al., 1991; Suzuki et al., 2007). These infectious clones have been used to genetically manipulate different regions of the viral RNA to define functions of viral proteins and RNA structures, to study virus–cell interactions, and to generate live-attenuated vaccine candidates. Another important advance has been the development of genomic and subgenomic DENV RNAs containing reporter genes, such as luciferase or green fluorescent protein (GFP) (Schoggins et al., 2012; Zou et al., 2011). These tools have been used to study functions of viral proteins and RNAs in each step of the viral life cycle (Samsa et al., 2012). Also reporter-containing viruses have been employed to study viral functions and host–virus interactions during viral entry, viral translation, RNA synthesis, and formation of infectious viral particles. Replicons are yet

another useful tool to evaluate translation and viral RNA amplification, which can be followed by measuring reporter activity as a function of time after RNA transfection.

Mature DENV particles have a diameter of  $\sim 500$  Å with an electron-dense core surrounded by a lipid bilayer, in which two transmembrane viral proteins are inserted forming a glycoprotein shell. The core contains the nucleocapsid formed by the viral RNA genome in complex with multiple copies of the capsid protein. The glycoprotein shell is well defined and consists of 180 copies of the envelope (E) and membrane protein (prM/M). The E protein is found as 90 head-to-tail homodimers that lie flat on the viral surface forming a smooth protein shell (Kuhn et al., 2002). The M protein is a small proteolytic fragment of its precursor prM that after cleavage of “pr” peptide during viral maturation remains as a transmembrane protein beneath the E protein shell. Inside the lipid bilayer, there is a low-density gap of  $\sim 12$  Å followed by the density contributed by the capsid protein with the viral genome.

Viral particles are initially assembled as immature virus with a distinct structural organization. In immature viral particles, the E glycoprotein is associated with the glycoprotein prM forming heterodimers (Zhang et al., 2003). The immature particle is converted into an infectious form by cleavage and release of “pr” peptide of the prM protein during viral.

## OVERVIEW OF THE VIRAL LIFE CYCLE

DENV enters host cells by receptor-mediated endocytosis, which involves binding of E to cellular receptors. DENV must recognize a ubiquitous cell surface molecule or utilize multiple receptors for cell entry. The interaction of E with glycosaminoglycans, such as heparan sulfate, at the cell surface and also several other surface proteins is implicated in the process of internalization such as heat-shock proteins 90 and 70, GRP78 (BiP) (Jindadamrongwech et al., 2004), neolactotetraosylceramide (Aoki et al., 2006), the lipopolysaccharide receptor CD14 (Chen et al., 2008b), and the 37/67 kDa high-affinity laminin (Thepparit et al., 2004), C-type lectins such as dendritic cell (DC)-specific intercellular adhesion molecule-3-grabbing nonintegrin (SIGN), the mannose receptor (Miller et al., 2008) and C-type lectin domain family 5, member A (Chen et al., 2008a) DENV enters mosquito and human cells through clathrin-mediated endocytosis (Krishnan et al., 2007).

DENV particles diffuse along the cell surface toward a preexisting clathrin-coated pit. With the aid of dynamin, the clathrin-coated pit evolves to a clathrin-coated vesicle, and this virus-containing vesicle is delivered to early endosomes, which subsequently mature into late

endosomes. Upon internalization and acidification of the endosome, fusion of viral and vesicular membranes mediated by conformational changes in the E protein (Modis et al., 2004; Nayak et al., 2009) allows the release of the nucleocapsid.

After the nucleocapsid is delivered into the cytoplasm, uncoating of the genome, which involves dissociation of the capsid protein from the RNA, takes place by an unknown process. The positive-sense viral RNA is released in the cytoplasm to function as mRNA. Translation of the single ORF at the RER produces a large polyprotein, which displays a complex topology on the ER membrane. The viral polyprotein is cleaved co- and posttranslationally into at least 10 mature proteins. The N-terminus of the polyprotein encodes three structural proteins (capsid, prM, and E), and the rest of the ORF encodes the seven NS proteins (*NS1–NS2A–NS2B–NS3–NS4A–NS4B–NS5*). Polyprotein maturation is carried out by host and viral proteases. The host signal peptidase at the ER lumen is responsible for the N-terminus cleavage of prM, E, NS1, and NS4B, whereas the processing of most of the other NS proteins, as well as the C-terminus of the capsid protein, is carried out by the viral protease NS2B3 in the cytoplasm of infected cells (Falgout et al., 1991). Finally, furin is the protease responsible of processing prM in the Golgi apparatus during viral particle maturation.

After the viral proteins have been translated and processed, virus-induced hypertrophy of intracellular membranes occurs, creating structures known as convoluted membranes (CMs) and vesicle packets (VPs). RNA synthesis takes place in close association with cellular membranes inside VP in the so-called viral replication complexes (RCs).

The process of replication begins with the synthesis of a complementary negative-strand RNA, which serves as template for the amplification of additional positive-strand genomic RNA. The enzymatic reaction is catalyzed by NS5, in association with NS3, other viral NS proteins, and presumably host factors. The newly synthesized genomes can be used for translation of more viral proteins or associate with capsid to generate new viral particles. Capsid distributes between ER membranes, nucleus, and the surface of lipid droplets (Samsa et al., 2012).

Once formed, the nucleocapsid buds into the ER lumen acquiring the lipid bilayer, together with the viral E and prM proteins. The newly produced particles travel through the secretory pathway. Furin-mediated proteolysis of prM in the trans-Golgi network triggers rearrangement, homodimerization of E, and formation of mature viral particles (Yu et al., 2008). Secreted viruses are a mixture of mature, immature, and partially mature particles.

## Genomic Structure of Dengue Virus

The DENV genome consists of a single, positive-strand RNA of ~11 kb. A type I cap is present at the 5' end, followed by the conserved dinucleotide 5'-AG-3' (Cleaves and Dubin, 1979). The 3' end of the genome lacks a polyadenylate tail and terminates in a conserved 5'-CU-OH 3' (Wengler and Wengler, 1981). The genome encodes a single ORF flanked by highly structured 5' and 3' untranslated regions (UTRs). The 5' and 3' terminal RNA sequences of the genome form large stem loop structures known as stem loop A (SLA) and 3' stem loop (3' SL), respectively, both essential for viral replication. The 5' UTR sequences of the four DENV serotypes (DENV-1 to DENV-4) are between 95 to 101 nucleotides long, while the 3' UTRs range from 470 nucleotides in the case of DENV-1 to ~385 nucleotides in DENV-4. An important feature of DENV and other flavivirus genomes is the presence of inverted complementary sequences (CSs) at the ends of the RNA. These sequences mediate long-range RNA–RNA interactions and cyclization of the viral genome (Villordo and Gamarnik, 2009) (Figs. 16.2 and 16.3).

Inverted CSs have been suggested to allow the ends of the genome to associate through base pairing, leading to circular conformations of the RNA. DENV-5' CS element was found within the coding sequence of capsid, and its CS 3' CS was identified within the 3' UTR, just upstream of the conserved 3' SL. Additional inverted complementary nucleotides, besides the original 5'–3' CS, were noticed using folding prediction algorithms (Leyssen et al., 2001; Thurner et al., 2004). A sequence located just upstream of the translation initiator AUG at the 5' UTR of DENV was found to be complementary to a region present within the stem of the 3' SL. This pair of CSs was named cyclization sequence

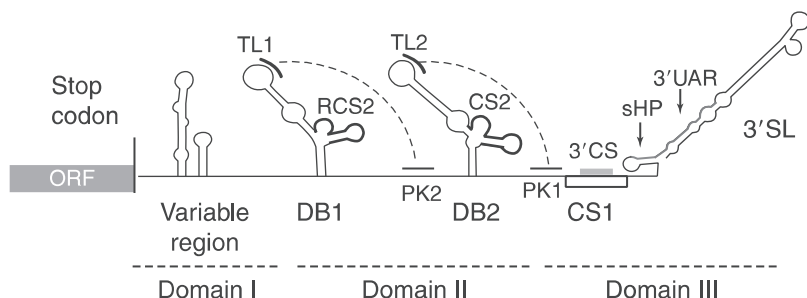

**FIGURE 16.2** Schematic representation of predicted RNA elements at the 3' UTR of the DENV genome. *DENV*, Dengue virus; *RNA*, ribonucleic acid; *UTR*, untranslated regions. Source: Adapted from Iglesias, N.G., Byk, L.A., Gamarnik, A.V., 2013. *Molecular virology of dengue virus*. In: Ooi, A.P.E.E., Gubler, D.J., Vasudevan, S., Farrar, J. (Eds.), *Dengue and Dengue Hemorrhagic Fever*. CAB International. pp. 334–365 (Iglesias et al., 2013).

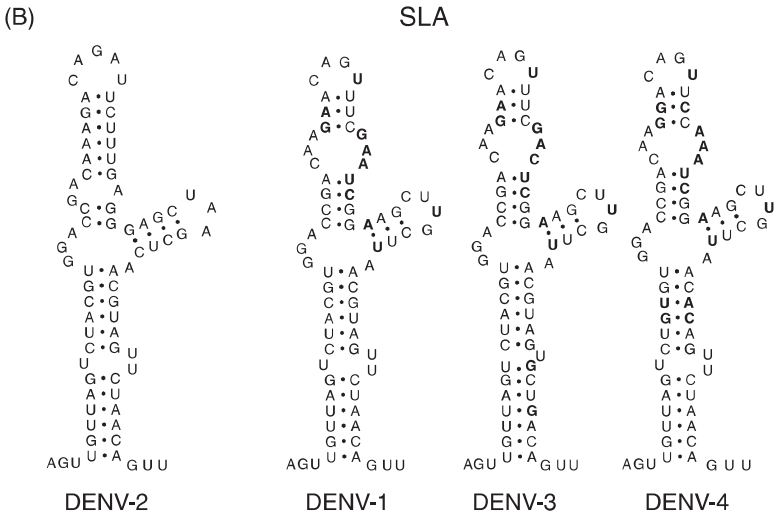
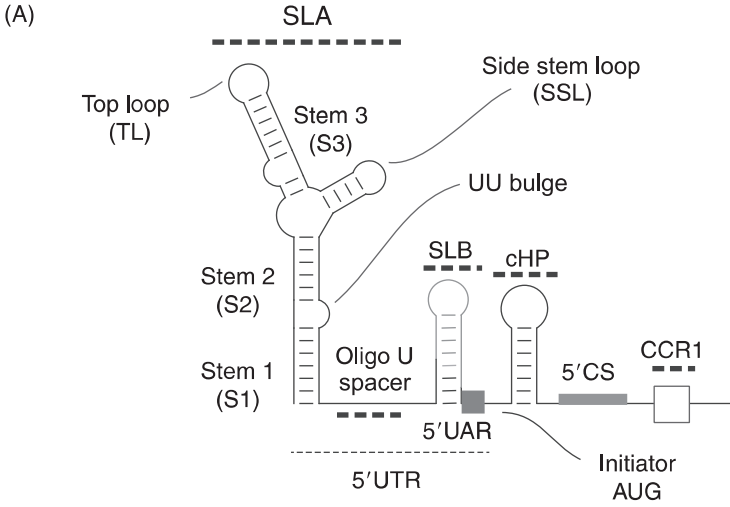

**FIGURE 16.3** (A) Structural elements located at the 5' end: SLA, SLB, UAR, oligo(U) spacer, translation initiator AUG, cHP, and the 5' CS element are indicated. Regions within the SLA including the TL, stem S1, stem S2, stem S3, and the SSL are shown. (B) Schematic representation of differences found between Side Stem Loop (SSL) DENV-2 and other DENV. *cHP*, Capsid region hairpin; *CS*, complementary sequence; *SLA*, stem loop A; *SLB*, stem loop B; *SSL*, side stem loop; *TL*, top loop; *UAR*, upstream AUG region. *Source:* Adapted from Iglesias, N.G., Byk, L.A., Gamarnik, A.V., 2013. *Molecular virology of dengue virus*. In: Ooi, A.P.E.E., Gubler, D.J., Vasudevan, S., Farrar, J. (Eds.), *Dengue and Dengue Hemorrhagic Fever*. CAB International. pp. 334–365.

5'–3' UAR (the name stands for upstream AUG region) (Alvarez et al., 2005a).

More recently, complementary nucleotides located between 5'–3' UAR and 5'–3' CS were found to be also important for efficient DENV replication. These sequences were named 5'–3' downstream AUG region (Friebe et al., 2012). Atomic force microscopy showed that long-range RNA–RNA interaction occurs in DENV genome (Alvarez et al., 2005b), also it showed that full-length DENV genomic RNA occurred in linear and circular conformations.

## 5' Untranslated Region

Alignment of the 5' UTRs from different DENV serotypes shows high sequence conservation. RNA-folding predictions of these sequences indicate the formation of a large 5' terminal SLA followed by a smaller stem loop structure [stem loop B (SLB)]. SLB ends in the translation initiation AUG codon and contains the CS 5' UAR. These two stem loop structures are separated by a short oligo(U) sequence. SLA portion of DENV genome shows three helical regions (S1, S2, and S3), a side stem loop (SSL) and a top loop (TL), and these structures play important role in viral replication. Between the SLA and the SLB structures, there is an oligo(U) track conserved in DENV and other flavivirus genomes that functions as spacer that enhances viral RNA synthesis (Lodeiro et al., 2009). The 5' UTR is followed by a structured RNA region in the coding sequence of capsid. This region, which is ~100 nucleotides long, contains three important RNA elements: (1) the highly conserved 5' CS, which is complementary to the 3' CS present at the viral 3' UTR; (2) a stable hairpin known as capsid region hairpin (cHP); and (3) an RNA element that modulates DENV replication in mosquito and mammalian cells (Fig. 16.3).

The 5' CS is 11 nucleotides long (134-UCAAUAUGCUG) and is absolutely conserved among the four DENV serotypes. This region mediates long-range RNA–RNA interactions between the ends of the genome and is essential for viral RNA replication. The cHP was originally described as an element that regulates the start codon selection during protein synthesis. RNA structures located within the protein coding sequence were found to play a regulatory role in DENV replication (Polacek et al., 2009). Mutations and deletions within a predicted hairpin (CCR1) resulted in important defects in DENV replication in mosquito and mammalian cells (Fig. 16.3).

## 3' Untranslated Region

The 3' UTRs of the four DENV genomes contain highly conserved RNA elements (Shurtleff et al., 2001). However, the length of this region

is different for the four serotypes. In the case of DENV-1 the 3' UTR is ~470 nucleotides long, 450 nucleotides for DENV-2, 430 nucleotides for DENV-3, and the shortest is for DENV-4 with 385 nucleotides 3' UTR can be divided in three domains (Proutski et al., 1997; Rauscher et al., 1997). Domain I is located immediately after the stop codon of NS5 and is considered the most variable region within the viral 3' UTRs. Domain II is of moderate conservation, comprising several hairpin motifs, including a characteristic dumbbell structure in DENV-1, DENV-2, and DENV-3, and a turret structure proposed in DENV-4 (Shurtleff et al., 2001; Silva et al., 2008). Domain III is the most conserved region of the 3' UTR, bearing a conserved sequence (CS1) followed by the terminal stem loop structure (3' SL). CS1 contains the cyclization sequence 3' CS involved in long-range RNA–RNA interactions (Hahn et al., 1987). Between serotypes there are few nucleotide variations in this region. Altered sHP formation impaired DENV replication (Villordo et al., 2010). The TL of the large terminal stem loop in DENV has a highly conserved ACAGAAC sequence.

In DENV the 3' SL contains a total of 93 nucleotides. The long stem is interrupted by mismatches in conserved locations, a six-nucleotide bulge is predicted near the top, and the loop contains seven nucleotides. Between serotypes there are few nucleotide variations in this region. Specific nucleotides of the 3' SL interact with other RNA elements of the viral genome to provide the correct conformation for initiation of RNA synthesis. It is also possible that the 3' SL provides a recognition site for protein binding during assembly of the RNA RC (Fig. 16.1).

The 5' and 3' ends of the flavivirus RNA genome contain complementary ribonucleotide sequences that lead to cyclization of the genome (Alvarez et al., 2006) (Fig. 16.4).

## VIRAL REPLICATION

Replication of DENV is associated with a dramatic rearrangement of host cellular membranes (Mackenzie et al., 1996; Uchil and Satchidanandam, 2003; Welsch et al., 2009). At least three different membranous structures have been described in flavivirus-infected cells. These structures were originally described as CM, paracrystalline arrays, and VPs. Most current studies support the ER origin of the VPs and CMs induced during DENV infection. CMs have been proposed as putative sites for flavivirus polyprotein processing. Role of CMs as storage site for proteins and lipids involved in viral replication has been proposed. Intermediate forms of RNA replication and most of the NS viral proteins have been observed inside VPs by electron microscopy (EM)

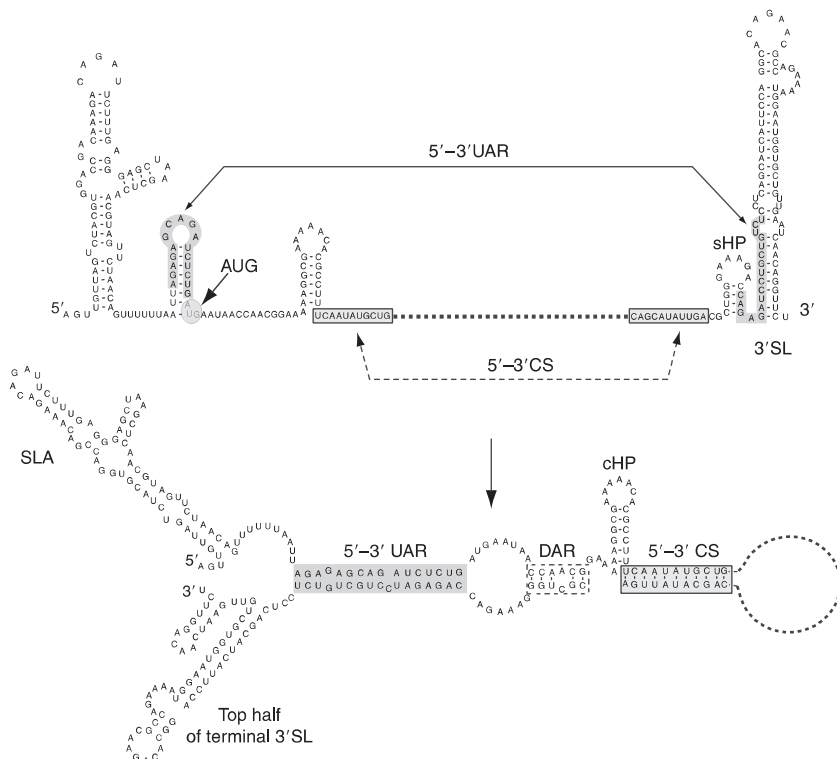

**FIGURE 16.4** Long-range RNA interactions between the ends of the DENV genome. *DENV*, Dengue virus; *RNA*, ribonucleic acid.

and confirmed by biochemical analysis (Mackenzie et al., 1996; Welsch et al., 2009; Westaway et al., 1997).

Viral RNA replication begins with the synthesis of a negative-strand RNA, which then serves as a template for the synthesis of additional positive strands. This process occurs in close association with cellular membranes (likely VPs) in the so-called viral RCs. The enzymatic reaction is catalyzed by the RdRp activity of NS5, together with NS3, other viral NS proteins, and presumably host factors. RNA synthesis is semiconservative and asymmetric, leading to 10-fold excess of positive over negative strands (Cleaves and Dubin, 1979). Three species of viral RNA can be metabolically labeled: (1) a ribonuclease-resistant double-stranded RNA (dsRNA) called replicative form; (2) a form partially resistant to ribonucleases, likely composed by RNAs with complementary nascent elongating strands, known as replicative intermediates; and (3) the genomic RNA that is fully sensitive to ribonucleases.



Studies show that viral proteins NS1, NS2B, NS3, NS4A, NS5, and for some viruses NS4B colocalize with dsRNA (Mackenzie et al., 1996; Welsch et al., 2009; Westaway et al., 1997). RNA synthesis occurs within the lumen of the vesicles, and the newly synthesized RNA genome exits via the identified pores that communicate with the cytosol.

Two viral proteins, NS5 and NS3, bear enzymatic activities directly involved in RNA replication. These proteins interact with different viral and host components and display multiple functions during viral infection. NS1, NS2A, NS2B, NS4A, and NS4B are also a part of the RCs involved in viral RNA amplification (Mackenzie et al., 1996; Westaway et al., 1997).

Upon entry, the viral genome is directly used as messenger for protein synthesis associated with the RER. The mature viral proteins reorganize cellular membranes to generate structures known as VPs, which will contain the RCs. After sufficient viral proteins are synthesized, translation stops, and the RNA is transported to the VPs by an unknown mechanism. It is possible that accumulated viral proteins or host factors induced by these proteins coordinate the switch from translation to RNA synthesis. Inside the VPs, the viral proteins NS4A, NS4B, and likely NS2A bind to the internal side of the membrane, while NS1 stays in the outer side (corresponding to the ER lumen). The viral polymerase NS5 and NS3 must be transported inside the VPs, presumably bound to the viral RNA. RNA transport could be mediated by NS proteins and possibly host factors. For RNA synthesis, NS5 specifically interacts with the SLA promoter at the 5' end of the genome. Base pairings between the ends of the RNA and cyclization of the genome allows relocation of NS5 to the 3' end of the molecule to initiate RNA synthesis. Hybridization between CSs 5'–3' UAR opens the bottom half of the highly structured 3' SL allowing initiation of negative-strand synthesis. NS5 synthesizes a dinucleotide CU de novo, which serves as the primer for RNA elongation. It has been proposed that the negative-strand RNA remains bound to the positive strand in a dsRNA form. The negative strand then serves as a template for positive-strand amplification. Multiple copies of positive-strand RNA are made from the negative strand, leading to an excess of positive versus negative strands.

The newly made genomes exit the VPs by pores that connect to the cytoplasm. These molecules either associate with the reorganized ER, presumably in CM structures, to mediate new rounds of translation of viral proteins, or associate with the capsid protein to form the nucleocapsid. The nucleocapsid then buds into the ER to generate a new viral particle (Fig. 16.5).

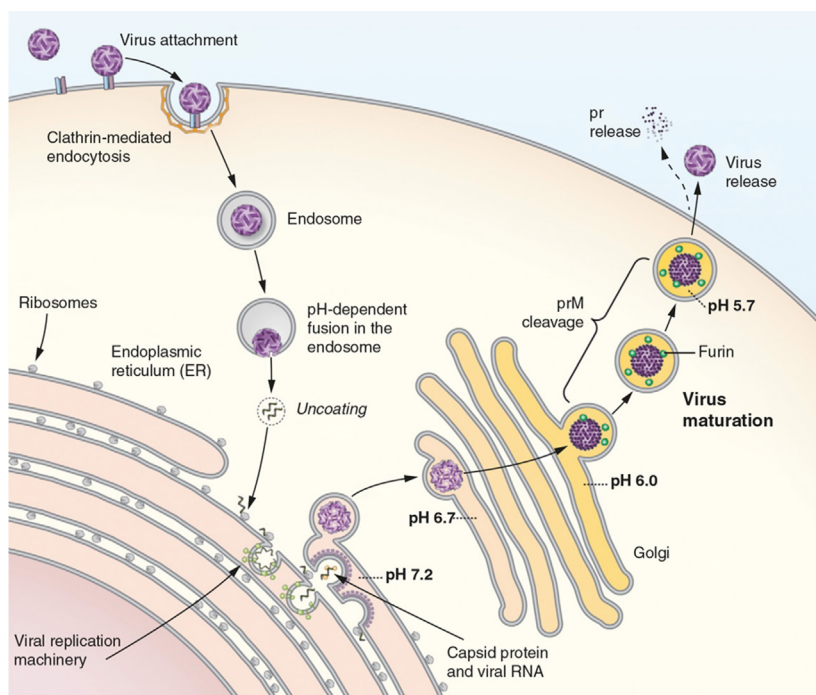

**FIGURE 16.5** The DENV life cycle. Source: Fischl, W., Bartenschlager, R., 2011. *Exploitation of cellular pathways by dengue virus*. *Curr. Opin. Microbiol.* 14 (4), 470475. Available from: <https://doi.org/10.1016/j.mib.2011.07.012>.

## Nonstructural Proteins

NS1 (48–50 kDa glycoprotein) (Muller et al., 2012) is found to interact with virus-induced vesicles inside the cell, secreted to the cell surface, or released into the bloodstream of infected individuals (Flamand et al., 1999; Winkler et al., 1988). It is thought to play an important role in virus replication because it is shown to colocalize with the viral RNA RC. Secreted NS1 (sNS1) is highly immunogenic and is involved in stimulating protective response against DENV (Mackenzie et al., 1996). It has been implicated in the early stages of flavivirus RNA synthesis (Lindenbach and Rice, 1997). This protein exists in multiple oligomeric forms and is found in different cellular locations. It can be associated with vesicular compartments, found in the cell surface or secreted and colocalizes with the RCs together with dsRNA, NS2A, NS3, NS4A, NS4B, and NS5 in VPs (Mackenzie et al., 1996; Westaway et al., 1997).

NS1 can exist in different oligomeric states. When it is associated with membranes, that is, in virus-induced vesicles or cell plasma membrane, NS1 exists in a dimeric form. When NS1 is secreted out of the cell, sNS1 becomes a hexamer (Gutsche et al., 2011). The structure is ~10 nm in diameter and 9 nm in height and exists as a barrel-like structure with dimers of sNS1 arranged as trimers and contain triglycerides, cholesterol, and charged lipids such as phosphatidylcholine and phosphatidylethanolamine (Muller et al., 2012).

NS2A (~22 kDa) is a small hydrophobic integral membrane protein that has been implicated in viral RNA synthesis, viral particle assembly (Xie et al., 2013). NS2A is an essential component of the replicase and also an inhibitor of interferon (IFN) production. Two forms of this protein (NS2A and NS2Aa) are observed as a result of an internal cleavage by the viral NS2B–NS3 protease. This suggests a physical interaction between NS2A and NS3. Interactions between NS2A and NS5 and with RNA transcripts of the 3' UTR have also been suggested (Lindenbach et al., 2007).

NS2B protein has 130 residues produced by posttranslational cleavage of the NS2B–NS3 protease at its terminal ends. NS2B is predicted to comprise three hydrophobic regions that span the membrane. In addition, a short and highly conserved hydrophilic stretch of residues (amino acids 49–95) is involved in the catalytic activation of the NS3 protease by acting as a cofactor (D'Arcy et al., 2006) and is essential for viral polyprotein processing (Anglero-Rodriguez et al., 2014).

NS3 protein (69 kDa) has various enzymatic activities essential for replication of viral genomic RNA: viral polyprotein proteolytic processing via its serine protease N-terminal domain, RNA helicase, nucleoside triphosphatase (NTPase), and RNA nucleoside 5' triphosphatase (RTPase) via its C-terminal domain. To be catalytically active, the N-terminal domain of NS3 must associate with a hydrophilic domain of the membrane-associated NS2B protein that acts as a cofactor. NS3 represents an important target for the development of specific antiviral inhibitors (Patkar and Kuhn, 2008; Reiser et al., 2005). NS3 bears multiple essential enzymatic activities. Besides the N-terminal two-component serine protease domain necessary for polyprotein processing, it contains three different enzymatic activities in the C-terminal domain: NTPase, RNA triphosphatase (RTPase), and RNA helicase (Benarroch et al., 2004; Yon et al., 2005). Other possible functions include unwinding dsRNA intermediates that arise during RNA amplification, destabilizing secondary structures of the RNA to increase polymerase processivity, participating in RNA recruitment at specific subcellular locations, acting as RNPs stripping proteins from the viral RNA, and remodeling RNA structures that may function as modulators of the viral processes. NS4B with NS3 was found to induce NS3 dissociation from

ssRNA and promote dsRNA unwinding activity (Umareddy et al., 2006). NS3 has been implicated in infectious viral particle formation (Patkar and Kuhn, 2008).

NS4A, a small transmembrane hydrophobic protein, is one of the least characterized proteins of the RC and is involved in the formation of VPs and CMs (Miller et al., 2007). NS4B contains several hydrophobic regions and colocalizes with dsRNA in DENV-infected cells (Miller et al., 2006). A topology model was proposed in which the N-terminal region of NS4A localizes in the cytoplasm while the remaining contains three transmission electron microscopy (TEM) segments (Miller et al., 2007).

NS4B is a hydrophobic protein of ~28 kDa. NS4B partially blocks activation of STAT1 and IFN-stimulated genes (ISGs) in cells stimulated with IFN.

NS5 is the viral enzyme responsible for RNA capping and RNA synthesis of positive and negative RNA strands (Issur et al., 2009; Yap et al., 2007). It is the largest and the most conserved of the viral proteins and contains an N-terminal S-adenosyl-methionine-dependent MTase involved in RNA cap formation and the C-terminal RdRp domain RdRp required for viral RNA synthesis (Bartholomeusz et al., 1994; Egloff et al., 2002). NS5 specifically copies the viral RNA. This specificity depends on a viral RNA structure that acts as a promoter present at the 5' end of the viral genome, known as SLA (Filomatori et al., 2006; Lodeiro et al., 2009). The N-terminal of NS5 from DENV is shown to possess guanine N7 and ribose 2'-O MTase activities involved in the formation of the 5' cap (Egloff et al., 2002).

NS5 also blocks type I IFN by binding and promoting STAT2 degradation (Ashour et al., 2009). DENV RNA synthesis requires specific interaction of NS5 with the SLA structure present at the 5' end of the viral genome. Both the 5' and the 3' ends of the RNA were necessary for polymerase activity. NS5 also has terminal transferase activity, which can interfere with in vitro studies to analyze the ability of the NS5 protein to copy RNA from a template. Specificity for NS5 RNA synthesis was provided by viral sequences present at the 5' end of the genome, and that 3' UTR elements were not necessary to promote RNA synthesis in vitro (Filomatori et al., 2006). DENV NS5 binds to the promoter SLA mainly through the RdRp domain (Filomatori et al., 2011; Iglesias et al., 2011). Crystallographic structures for the RdRp domain of WNV and DENV (serotype 3) (Egloff et al., 2007; Yap et al., 2007) show a right hand-like structure composed of fingers, palm, and thumb subdomains. An unexpected observation in the structure of the RdRp from DENV was the presence of two zinc ions in the thumb and fingers subdomains, respectively.

## Structural Proteins

*Capsid* (12 kDa) is a highly charged basic protein. It is detected in both the cytoplasm and nucleus (Sangiambut et al., 2008). The primary role of the capsid in the cytoplasm is to assemble virus particles by interacting with both the viral RNA genome and the ER membrane (Markoff et al., 1997) and is known to interact with some nuclear proteins (e.g., histones, nucleolar RNA helicase, importin-a/b) (Bhuvanakantham et al., 2009; Netsawang et al., 2010; Xu et al., 2011) and is able to cause apoptosis. Capsid protein consists of a disordered N-terminal end, followed by four helices ( $\alpha 1$ ,  $\alpha 2$ ,  $\alpha 3$ , and  $\alpha 4$ ). The disordered N-terminal end and  $\alpha 1$  are highly positively charged. This is followed by hydrophobic helices  $\alpha 2$  and  $\alpha 3$ , and the amphipathic  $\alpha 4$ . The highly charged N-terminal end and  $\alpha 4$  could be important for RNA binding (Westaway et al., 1997) while helices  $\alpha 2$  and  $\alpha 3$  interact with the lipid membrane (Markoff et al., 1997).

*E protein* is the major antigenic structure on DENV. It is involved in both host cell receptor recognition and fusion of the virus to the endosomal membrane during cell entry (Rey et al., 1995). The E protein is thought to exist as dimers and when exposed to low pH, which mimics the condition in the endosome, the E protein rearranges to form trimers (Bressanelli et al., 2004; Modis et al., 2004). E protein is an elongated protein mainly composed of  $\beta$ -strands. It is organized into three domains: the central domain I, the dimerization domain II, and the IgC-like domain III. Each dimer is assembled from two monomers arranged in a head-to-tail format. The tip of domain II contains the fusion loop, which interacts with the endosomal membrane during the fusion event (Modis et al., 2004).

The mechanism of fusion of E protein leads to internalization of DENV has been proposed by (Modis et al., 2004) and involves domain II and domain III in the following manner. In the low pH environment of the endosome, the domain II of the E protein flips up, exposing its fusion loop, thereby leading to the insertion of the fusion loop into the endosomal membrane. The membrane may then catalyze trimerization, causing the formation of a prefusion intermediate. Trimerization then spreads from the fusion tip of E protein downward to domain I at the base of the trimer. Domain III then rotates and shifts, displacing the trimers, which in turn cause the endosomal and viral membrane to fuse. The fusion of membranes may require concerted twisting of a few trimeric E proteins.

*prM* protein is present at the newly synthesized immature virus surface, while its furin protease-cleaved derivative, the M protein, is present on the mature infectious virus. The prM protein consists of a 91-residue N-terminal pr molecule followed by a 38-residue M ectodomain and a

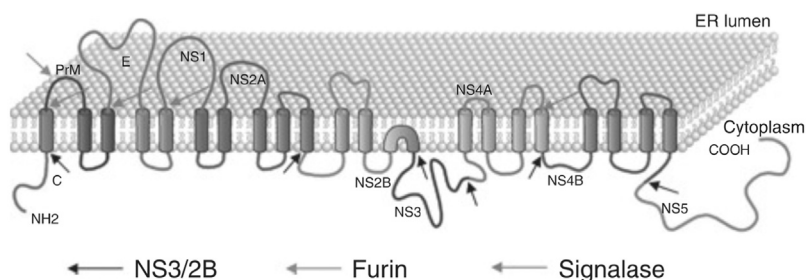

**FIGURE 16.6** Arrangement of nonstructural and structural proteins of dengue in replication complex.

35-residue TM region. The primary role of the pr molecule is to cap the fusion loop of the E protein, thus preventing the newly synthesized virus from fusing back into the cell, when moving through the acidic compartments of the trans-Golgi network. On the other hand, the function of the M protein remains largely unknown. The pr peptide consists of mainly antiparallel  $\beta$  strands. It caps the fusion loop of the E protein, which is consistent with its proposed function in preventing virus from fusing back into the cell during exocytosis (Li et al., 2008) (Fig. 16.6).

## Pathogenesis of Dengue

### **Viral Factors**

Viral virulence is influenced by viral genetics (which is “intrinsic” to the virus) and by host factors such as preexisting immunity and host genetics (factors that are “extrinsic” to the virus). Certain DENV strains demonstrate greater epidemic potential, as they replicate better either in humans or in the mosquito vector and, therefore, have the potential to displace strains with lower relative replicative ability in either host. Enhanced replication in mosquitoes may contribute to global spread and success of a strain due to faster dissemination in the mosquito and a shorter extrinsic incubation period (Anderson and Rico-Hesse, 2006; Gubler and Rosen, 1977). Also cross-reactive immune responses in human populations may also confer a selective advantage to particular clades or genotypes of DENV, such that strains capable of evading host adaptive immune responses are able to outcompete other strains in the population (OhAinle et al., 2011; Vu et al., 2010).

Halstead proposed that DENVs share common immunodominant epitopes due to their amino acid identity which may be 60%–70% between the four serotypes which was termed as “sequential infection” (Halstead, 1970). Genetic changes in certain viral strains confers in them



greater virulence compared to others and is probably the reason for variation in severity of dengue epidemics as per then-proposed alternate hypothesis called the “virus virulence” hypothesis (Rosen, 1977) and is supported by the several studies. DENV virulence is often tightly linked to host immune status, and it is particularly difficult to separate the role of viral versus host factors, including host genetics (OhAinle et al., 2011; Steel et al., 2010).

More fit DENV strains have been proposed to pose increased risk of causing severe disease than less fit strains due to their propensity for higher replication in the human host (Rico-Hesse, 2010). Viremia levels in patients have been associated with disease severity in several studies (Avirutnan et al., 2006; Libraty et al., 2002b; Tricou et al., 2011).

Three mechanisms of increased viral replication have been proposed that would allow for higher viral replication in the human host, leading to higher pathogenicity through more robust infection of target cells and resultant exacerbated cytokine cascade: (1) More pathogenic DENV strains replicate more productively in human cells and thereby replicate to higher titers (Cologna and Rico-Hesse, 2003); (2) more pathogenic DENV strains may evade host adaptive, cross-reactive immune responses (Kochel et al., 2002; Mongkolsapaya et al., 2006); or (3) antibody-mediated infection may increase viral replication through infection of more target cells (Balsitis et al., 2010; Boonnak et al., 2008; Zellweger et al., 2010) or increased viral output from infected cells. Also inappropriate cross-reactive adaptive immune response during sequential DENV infection may lead to the more severe immunopathogenesis, that is, characteristic of DHF/DSS. Changes in viral proteins that interact with the host may impact viral virulence. Such interactions include the interaction of NS1 with the host complement pathway (Avirutnan et al., 2006), potential immune recognition of NS1 bound to endothelial cells of the vascular system (Avirutnan et al., 2007; Chen et al., 1997), or cleavage during maturation of NS4B that appears to induce immunomodulators from monocytes that increase endothelial cell permeability (Kelley et al., 2012). Finally, differences in the breadth of diversity of circulating DENV genomes during acute infection (“intra-host diversity”) have been hypothesized to play a role in determining disease outcome (Descloux et al., 2009).

Halstead et al. have demonstrated that isolates from cases of severe dengue disease grew better in human monocytic cells than isolates from mild symptomatic illness. Also increased virulence of Asian DENV-2 in human infections has been linked to its enhanced replication *in vitro*. Mutations at certain position might increase or decrease their virulence based on the site of mutagenesis. In addition to mutations that may alter the replicative ability of DENV viruses in human cells, some viruses may also be less sensitive to elimination by the host immune system,

including reduced neutralization by the host humoral (antibody-mediated) response.

The four DENV serotypes all have the ability to cause severe and fatal disease in humans, although DENV-2 and DENV-3 are more often associated with severe disease. Some serotypes are less symptomatic as a primary infection, while others are often symptomatic and can even lead to severe disease during primary infection (Balmaseda et al., 2006; Fried et al., 2010; Nisalak et al., 2003). In addition, viral strains within each serotype may differ from one another in their ability to both infect and cause symptomatic disease in either naïve or DENV-immune individuals (primary or secondary infection). Specific sequence of infection by heterologous serotypes may be important in determining disease outcome (OhAinle et al., 2011).

In interepidemic periods, DENV is thought to be maintained in endemic populations through silent transmission, during which time the virus may undergo significant evolution. Also it is seen that DENV evolves over a single epidemic season, such that viruses isolated at the end of an epidemic differ from viruses isolated earlier but mechanism for such changes are unclear (OhAinle et al., 2011).

### **Host Factors**

Age is a risk factor for the development of severe disease and death from DENV infection. Many studies indicate that the incidence of DSS was highest in children aged between 6 and 10 years, and younger children had a significantly higher chance of dying from their infection (Anders et al., 2011). And may be due to reason that younger children have an intrinsically more permeable vascular endothelium and are therefore more prone to significant plasma leak (Gamble et al., 2000).

Host genetics play a vital role in susceptibility to DENV infection and studies show that people with an African ancestry have a reduced risk of developing severe disease as compared to those with European ancestry (Bernardo et al., 2005; Guzman et al., 2002). Recent genome-wide association studies (GWAS) has helped in establishing link between host genetics and disease susceptibility. Highly polymorphic human leukocyte antigen (HLA) alleles have been proposed to have an association with either disease susceptibility or protection (Coffey et al., 2009). HLA-A\*0203 was associated with less severe disease irrespective of the infecting serotype, whereas HLA-A\*0207 was associated with more severe disease only in patients with secondary DENV-1 and DENV-2. In contrast, HLA-A\*B51 was associated with more severe disease irrespective of serotype, and HLA-A\*B52 was associated with a less severe disease phenotype in secondary infections with DENV-1 and DENV-2. In addition, various HLA-B alleles (B44, B62, B76, and B77) appeared to protect against the development



of clinical disease from secondary DENV infection (Stephens et al., 2002). Also, HLA-A\*24 was overrepresented in patients with severe disease, whereas HLA-DRB1\*0901 was underrepresented, suggesting an association with susceptibility and protection, respectively (Nguyen et al., 2008).

Several other gene polymorphisms are also associated with DENV infection few such are tumor necrosis factor (TNF)-308A allele and increased susceptibility to severe manifestations of DENV infection (Perez et al., 2010), and a possible protective association between the TNF-238A allele and severe DENV infection (Garcia et al., 2011) and increased frequency of the transforming growth factor - beta 1 (TGF- $\beta$ 1) 509 CC genotype in cases of DHF, as compared to the milder DF (Cheng et al., 2009). The genotype of a single nucleotide polymorphism (SNP) at position 352 of the VDR gene was associated with protection from severe dengue (Loke et al., 2002). They also showed that homozygotes for the arginine variant at position 131 of the Fc $\gamma$  receptor (Fc $\gamma$ R) II gene appeared to be protected from the development of severe DENV infection. Viral binding to platelets via human platelet antigens may result in the thrombocytopenia observed in severe infection. The G allele of DC-SIGN1-336 appears to protect against milder DENV infection, DF, but not against more serious disease (Sakuntabhai et al., 2005).

GWAS demonstrated susceptibility loci for severe dengue at major histocompatibility (MHC) class I (MHC I) polypeptide-related sequence B (*MICB*) (rs3132468) on chromosome 6 and phospholipase C, epsilon 1 (*PLCE1*) (rs3765524) on chromosome 10 (Khor et al., 2011). *MICB* and other genes associated with natural killer (NK) cell activation are highly expressed in acute dengue infection.

Host immune response is considered to contribute to many of the clinical complications associated with severe dengue. Capillary permeability develops at a time when the viral burden is in sharp decline, arguing against a direct virus mediated effect on the vascular endothelium. Further, the most severe complication of capillary permeability, DSS, manifests when many patients have low or undetectable viremia levels and are already or very nearly afebrile (Simmons et al., 2012). A second line of evidence in support of the immune pathogenesis model of severe dengue lies in the observation that the vast majority of severe dengue complications occur in patients with immunological evidence of a previous history of DENV exposure or, in the case of infants, those with maternally acquired anti-DENV antibody.

Production of proinflammatory cytokines by immune cells during the course of infection is a key mechanistic process of capillary permeability and that the vasodilatory potential of some cytokines that occur in elevated concentrations during acute dengue and are linked to endothelial cell dysfunction. This hypothesis of a "cytokine storm"-mediating capillary permeability supports the ADE hypothesis (greater virus burden)

with the concept of immune activation of memory, cross-reactive T cells in secondary infection.

## Host Immune Response

### ***Antibody Response in Primary and Secondary Infection***

The kinetics of antibody production in dengue follow the typical course found in many viral infections with an initial phase of IgM production followed by IgG. During a primary DENV infection, antidengue IgM levels will begin to rise 3–5 days following the onset of fever and are detected in almost all cases following defervescence. Over the next 2–3 months, IgM levels fall and are replaced by IgG, which can be detected lifelong and are proposed to provide protection from repeat infection with that serotype, but not against reinfection with a different serotype (Halstead, 1988; Innis et al., 1989; Kurane, 2007; Sabin, 1952; Summers et al., 1984).

Following a secondary infection, the rise of IgM is much less marked than following primary infection and can be absent; instead, IgG levels rise more rapidly and to a higher peak. This difference forms the basis of tests to distinguish primary from secondary dengue infections; a primary infection is inferred if the IgM:IgG ratio is  $>1.8$  and conversely a secondary infection is inferred if the ratio is  $<1.8$  (Innis et al., 1989).

ADE was proposed by Halstead and O'Rourke to explain the increase in severity seen in secondary dengue infections. This proposes that due to the large sequence diversity in DENVs, antibody made to the primary infecting virus will not be of sufficient avidity or titer to neutralize a secondary infecting virus. Instead these low avidity cross-reactive antibodies may opsonize the virus and lead to its targeting of FcR bearing cells such as macrophage/monocytes, leading to internalization and increased virus replication. Fc-RIa and Fc-RIIa have been shown to promote ADE and cytoplasmic domains that contain immuno-tyrosine activation motifs are essential for this function by promoting endocytosis of immune complexes (Halstead and O'Rourke, 1977a,b).

ADE is therefore a phenomenon of failed neutralization where the density of antibody binding is insufficient to cause neutralization but large enough to pass the threshold required to direct opsonized virions to Fc receptor-mediated internalization. ADE has been demonstrated to increase virus replication in primate models following passive transfer of polyclonal human serum or monoclonal antibodies (mAbs) (Gonzalez et al., 2007; Halstead et al., 1973a). Anti-prM antibodies are a particularly interesting group of antibodies with respect to ADE. Anti-prM antibodies show poor neutralization and typically, even at high concentrations, neutralization plateaus at 30%–50%. The reason for this

is likely to do with virus maturation; fully mature virus particles do not contain prM and are thus not neutralized, whereas many partially mature virus particles contain enough prM to bind antibody and drive ADE but do not have enough prM epitopes to allow sufficient antibody density for neutralization. Furthermore, virions with high levels of prM are not infectious but can be driven to infect cells by ADE with anti-prM antibodies (Dejnirattisai et al., 2010; Rodenhuis-Zybert et al., 2010). This results in endocytosis and sufficient prM processing to allow membrane fusion.

There are a number of ways in which antibodies can protect from viral infection; in simple terms, antibodies may block adhesion to a cellular receptor, block fusion with host cell membranes, or alternatively destroy virus or virus-infected cells via complement or antibody-dependent cell-mediated cytotoxicity. Finally, antibody may opsonize virus and direct it for disposal via Fc receptor–mediated uptake.

How an antibody blocks viral entry is being explained by a number of theories of which the two being prominent are the single-hit model and multiple-hit model. The single-hit model proposes that interaction of antibody with a single or small number of critical epitopes may lock the virus into a conformation that prevents infection (Dulbecco et al., 1956). The multiple-hit model conversely proposes that rather than there being critical epitopes, neutralization is achieved when a proportion of the virion surface is occluded by antibody, thus interfering with viral attachment and/or fusion (Della-Porta and Westaway, 1978).

Anti-NS1 has been shown to reduce virus replication *in vivo*, which has been proposed to be mediated by either antibodies/complement or cell-mediated cytotoxicity (Amorim et al., 2012; Costa et al., 2006; Wu et al., 2003). NS1/anti-NS1 immune complexes can activate complement and have been proposed to drive complement consumption and promote vascular leak (Avirutnan et al., 2006). Finally, anti-NS1 antibodies have been shown to cross-react with unknown epitopes on platelets and endothelium and have been proposed to drive dengue pathogenesis (Lin et al., 2006). The ability of an antibody to neutralize a virus is thus related to its functional avidity for the whole virion.

### ***T-Cell Responses in Dengue Infection***

T cells recognize short antigenic peptides bound in the peptide binding groove of MHC I or MHC class II (MHC II) molecules. The peptides bound by these molecules are normally short fragments derived from the degradation of normal cellular proteins. However, during infection they can acquire and present peptides from a replicating pathogen. In general, MHC I molecules bind peptides derived from proteins expressed intracellularly such as a virus replicating in its host cell and present these to cytotoxic CD8 T cells. MHC II molecules on

the other hand present peptides derived from endocytosed antigens to CD4 T cells.

Peptide prediction algorithms and the ability to synthesize large numbers of peptides has helped us in understanding the T-cell response in a DENV person. Using these techniques, a large number of epitopes for MHC I and MHC II have been mapped. And NS3 seems to be the most immunodominant region of the virus with many CD4 and CD8 epitopes described in humans (Duangchinda et al., 2010; Kurane et al., 1989).

### ***T-Cell Responses in Secondary Dengue Infection***

Many of the T cells induced in the secondary infection showed poor responses to secondary infecting virus and T cells in DHF produced more cytokines and showed less degranulation than in DF, where T cells showed much higher levels of degranulation in the absence of cytokine production (Duangchinda et al., 2010). Many of these are raised, and in some the peak in their levels coincides with the onset of severe symptoms. High levels of TNF- $\alpha$ , IFN- $\gamma$ , IL-1RA, IL-6, IL-8, IL10, IL-12, IL-13, IL-18, TGF- $\beta$ 1, MCP-1, MIF, soluble TNFR-I, soluble TNFR-II, CXCL-9, CXCL-10, CXCL-11, and RANTES have been recorded, and many of these can be the products of activated T cells (Dejnirattisai et al., 2008). DHF may result from T cell-mediated immunopathology. Immunopathology is being increasingly recognized in a number of viral diseases where the protective antiviral response, although capable of controlling a virus, may cause considerable inflammation and tissue damage that can in some instances be fatal (Friberg et al., 2011; Mongkolsapaya et al., 2006).

### ***Innate Immune Responses in Dengue Virus Infection***

DENV counteracts two important elements of innate immunity, namely, the complement and the type I IFN pathways. These counteracting mechanisms allow the virus to establish infection in humans and possibly affect the generation of effective adaptive immune responses that are initiated and regulated by DCs. Moreover, some of the elements involved in antiviral innate immune responses are targeted by DENV.

DENV has been shown to trigger complement activation *in vitro* and *in vivo* (Avirutnan et al., 2006). Complement likely functions to limit DENV infection by stimulating adaptive immune responses and by neutralizing infection. Fc $\gamma$ R engagement by antibodies *in vitro* and *in vivo* can paradoxically enhance replication of DENV (Balsitis et al., 2010; Zellweger et al., 2010). Complement also augments antibody-mediated neutralization of flaviviruses, including YFV, DENV, and WNV (Mehlhof et al., 2009). In myeloid cells that express complement receptors, antibody-dependent complement activation paradoxically may enhance flavivirus infection (Cardosa et al., 1983).

Antibody and complement-dependent opsonization may augment DENV infection in myeloid cells. In early clinical studies, reduced levels of C3, C4, and factor B, and increased catabolic rates of C3 and C1q were observed, particularly in patients with severe DENV disease during secondary infection (Bokisch et al., 1973). In addition, C3 split products and anaphylatoxins (C3a and C5a) accumulated in the circulation of ill patients and peaked at the day of maximum vascular leakage (Malasit, 1987). DENV-infected cells may display sufficient amounts of DENV antigens (prM, E, or NS1 proteins) on their surface to facilitate immune complex formation and complement deposition. Indeed, DENV-infected endothelial cells activate human complement in the presence of antibodies resulting in C5b-9 deposition (Avirutnan et al., 2006).

Type I IFN production cascade is triggered after virus infection, because the sensors for this cascade, including Toll-like receptors (TLRs), and cytoplasmic receptors, such as retinoic acid-inducible gene 1 (RIG I) and MDA5, or RIG I–like receptors (RLRs) can detect virus-specific elements (PAMPs) and initiate the cascade (Ashour et al., 2010). The activation of this cascade results in the production of IFN $\alpha$  and IFN $\beta$  (type I IFNs) by cells and the subsequent secretion of these antiviral cytokines that can act in an autocrine or paracrine manner by binding to the IFN $\alpha\beta$  receptors and triggering the IFN signaling cascade; this culminates in the activation of ISGs-containing IFN-stimulated response elements that have antiviral activity (Kawai and Akira, 2007). DENV has been reported to be sensed by several TLRs and RLRs, including TLR3, TLR7, RIG I and MDA5 (Nasirudeen et al., 2011). Several DENV proteins had been identified as inhibitors of type I IFN signaling. By inhibiting both the detection and effector arms of this important pathway, the virus can stop the production of type I IFNs that would trigger the induction of hundreds of ISGs. Also DENV can inhibit the production of type I IFN in infected primary human cells, such as monocytes, monocyte-derived DCs, and monocyte-derived macrophages. This inhibition is mediated by an active protease complex (NS2B3) which targets a key host factor, STING (also named MITA) (Morrison et al., 2012). STING is an adaptor molecule for type I IFN production that mediates the phosphorylation of the transcription factor IRF3, which then translocates to the nucleus and participates in the activation of the IFN $\beta$  promoter. In addition to the direct effects on viral replication, by inhibiting type I IFN production in human DCs, DENV may affect the quality of the adaptive immune response generated after infection.

## Clinical Features of Dengue

### *Symptomatic Dengue*

Following an infectious mosquito bite there is an incubation period of up to 2 weeks (commonly 5–7 days), after which the individual

develops symptoms suddenly and the illness typically follows three phases—an initial febrile phase, a critical phase starting around 4–5 days from fever onset when complications may develop, followed by a spontaneous recovery phase.

### ***Febrile Phase—Commonly Lasts for 3–7 Days***

The patient experiences sudden onset of high fever (39°C–40°C) accompanied by nonspecific constitutional symptoms, including headache, general malaise, nausea, vomiting, myalgia, and joint pain (Biswas et al., 2012; Sirivichayakul et al., 2012).

Other common symptoms include altered taste sensation, colicky abdominal pain, constipation or diarrhea, and occasionally dysuria. Cough, sore throat, and rhinorrhea are sometimes present (Gregory et al., 2010). Occasionally the temperature may rise as high as 40°C–41°C during these first few days, and febrile convulsions may occur in susceptible children.

On examination during this phase of the illness facial flushing, conjunctival suffusion, and generalized truncal erythema may be noted. A faint macular or maculopapular rash is present in some cases. Generalized mild enlargement of the lymph nodes is common. The liver is often palpable, soft, and a little tender, although rarely markedly enlarged and jaundice is unusual. Splenomegaly is occasionally observed in small infants. Mild hemorrhagic manifestations such as skin petechia and/or bruising at venepuncture sites are sometimes noted. Mucosal bleeding, from the nose, gums, gastrointestinal, or genitourinary tracts, does sometimes occur.

Laboratory findings include mild-to-moderate thrombocytopenia and leukopenia, often with mild elevation of hepatic transaminases (Biswas et al., 2012; Kalayanarooj et al., 1997).

### ***Critical Phase***

Critical phase onset occurs from around days 3–6 of illness, lasting for 48–72 hours. A number of systemic problems may develop during this phase of the illness. The most feared complication is an unexplained “vasculopathy,” whereby an increase in vascular permeability results in a capillary leakage syndrome. Profound plasma losses leading to potentially fatal hypovolemic shock occur in a small proportion of cases. The altered capillary permeability is often accompanied by hemorrhagic manifestations and hematological abnormalities. No specific event defines the timing of onset of this phase, but vascular leakage often becomes apparent from around days 3–4 of illness, with shock (if it occurs) typically developing within 24 hours of defervescence.

A major increase in vascular permeability resulting in severe plasma leakage will typically result in cardiovascular collapse within hours.

Pleural effusions, ascites, and overt signs of cardiovascular decompensation will become apparent in the end. DSS is estimated to be developed in <10% of cases (Trung et al., 2012). Ultrasound studies indicate that pleural effusions, ascites, and gall bladder wall edema are commonly present during the critical phase and correlate with disease severity. Hypoproteinemia is well recognized during the critical phase and correlates with the severity of leakage (Wills et al., 2004). However, clinical identification of increased permeability is difficult until or unless DSS develops.

The most common method of monitoring leakage relies on identification of relative hemoconcentration. Unfortunately, the method is rather insensitive, particularly if the patient is receiving parenteral fluid therapy, and suffers from the serious limitation that an individual's baseline value is rarely known, so that final assessment of hemoconcentration may not be possible until the acute illness has resolved. Narrowing of the pulse pressure indicates that plasma volume depletion has reached a critical point and implies that decompensated shock will soon follow. If fluid resuscitation is not instituted promptly as soon as the pulse pressure narrows, the ongoing depletion of plasma rapidly becomes critical, the systolic pressure falls and irreversible shock and death may follow despite aggressive resuscitation. Profound or prolonged shock is often complicated by tissue hypoxia, metabolic acidosis, and disseminated intravascular coagulation (DIC). Also liver failure, renal failure, and encephalopathy are seen in association with profound shock.

### **Hemorrhagic Manifestation**

Bleeding in gastrointestinal tract is typically seen in patients with profound or prolonged shock complicated by metabolic acidosis and/or DIC. Minor epistaxis, gum bleeding, and gastrointestinal bleeding are sometimes observed in children without shock (Carlos et al., 2005), but bleeding from mucosal surfaces tends to be both more common and more severe in adult. Intracranial hemorrhage is a very rare but often fatal complication (Wani et al., 2010).

### **Hematological Abnormalities**

Some degree of thrombocytopenia, leukopenia, and deranged hemostasis is virtually universal during the critical phase (Biswas et al., 2012; Trung et al., 2012). Moderate-to-severe thrombocytopenia is common. The typical evolution of the thrombocytopenia is consistent with early marrow suppression of megakaryocytopoiesis, followed by increased peripheral destruction of platelets from the late febrile to the early convalescent phase of the disease probably mediated by the evolving immune response to the infection. During the febrile phase, there is also



a reduction in the number of total leukocytes and neutrophils, together with a relative increase in lymphocyte numbers that often includes a high proportion of atypical lymphocytes (Kalayanarooj et al., 1997; Khan et al., 2010).

### ***Recovery Phase***

#### **Recovery Phase Is Around Days 6–8 of Illness**

The increased vascular permeability and abnormal hemostasis are transient and usually resolve within 48–72 hours. However, convalescence may be prolonged in adults, who sometimes experience profound tiredness, esthenia, and depression for several weeks after recovery (Seet et al., 2007b). Loss of hair has also been reported during convalescence. Dysfunction of specific organs (e.g., hepatic failure or myocarditis) may persist for several weeks after resolution of the vasculopathy (Qiu et al., 1993).

### ***Factors Influencing Dengue Disease Severity***

Children and the elderly have a lower threshold for leakage than adults (Gamble et al., 2000). Primary infections in children are often asymptomatic or may cause a relatively benign nonspecific febrile illness (Endy et al., 2002). Studies have shown that children have greater risk for vascular leakage and development of DSS compared with adults (Anders et al., 2011; Trung et al., 2012).

Dengue associated mortality also appears to be higher in pregnant than nonpregnant women with dengue (Adam et al., 2010). With respect to fetal outcomes, infection is not known to be associated with fetal malformations (Tsai et al., 2010).

Comorbidities such as bronchial asthma, sickle cell anemia, and diabetes mellitus could be risk factors for development of severe disease forms (Gonzalez et al., 2005). Diabetes mellitus and hypertension were associated with severe disease (Pang et al., 2012). Also diabetes mellitus, asthma, hypertension, ischemic heart disease, and chronic kidney disease were present in the majority of those who died (Leo et al., 2011).

## **Complications**

### ***Skin***

Prominent flushing of the skin, especially the face, neck, and chest, may be seen in around 20% of dengue patients. A blanching macular or maculopapular rash has been described in up to 30% of patients, first developing between days 2 and 6 of illness (Trung et al., 2012).



## **Eye**

Mild nonspecific symptoms to severe complications can result in permanent visual loss, conjunctival injection, and subconjunctival hemorrhage. Retinal hemorrhage, retinal edema, macular ischemia, macular edema, vitreous hemorrhage, vitritis, and optic neuritis or papillitis have been reported infrequently (Siqueira et al., 2004b).

Musculoskeletal symptoms are a prominent feature of dengue, particularly among adult patients. Almost all adults experience some degree of myalgia, with associated arthralgia in around one-third of patients, and these features can be helpful in distinguishing dengue from other febrile illnesses. Creatine kinase levels are sometimes said to be markedly elevated, lactate dehydrogenase, and/or aspartate aminotransferase levels were found to be higher in dengue-infected subjects (Wang et al., 2009).

## **Gastrointestinal Tract**

Anorexia, nausea, vomiting, diarrhea, and abdominal pain were all reported more commonly. Nausea, vomiting, and anorexia are usually found in the first 5 days of illness, while abdominal pain tends to develop slightly later, between days 3 and 6 of illness. Persistent vomiting and increasingly severe abdominal pain or tenderness are considered as warning signs for likely progression to severe disease. Liver dysfunction, described in terms of increased hepatic transaminase levels, is very common (Sirivichayakul et al., 2012).

Potential mechanisms for hepatic injury involve a variety of possible insults, including direct effects of the virus or host immune response on liver cells, circulatory compromise, and/or hypoxia due to hypotension or localized vascular leakage inside the liver capsule, hepatotoxic effects of drugs such as acetaminophen or traditional herbal remedies, and tissue tropism of particular viral serotypes or genotypes.

## **Kidney and Genitourinary Tract**

Microscopic hematuria is found in around 20%–30% of dengue patients during the acute illness. Acute renal failure is a rare complication, usually found in association with severe DSS, typically in patients with prolonged shock and multiorgan involvement.

## **Heart**

The most common cardiac manifestations of dengue are arrhythmias. Several case reports have also described disturbances such as sinoatrial block with atrioventricular dissociation, and atrial fibrillation, during the critical phase (Kaushik et al., 2010; Mahmud et al., 2009). During convalescence, rhythm disturbances such as sinus

pauses, first-degree heart block, and Mobitz type I atrioventricular block have all been described, as well as atrial and ventricular ectopy.

## Laboratory Diagnosis

Diagnosis is important for clinical care, surveillance support, pathogenesis studies, vaccine, and drug development and clinical trials (Guzman and Kouri, 2004). Direct (virus isolation, RNA, and antigen detection) and indirect methods (serological investigations) constitute the dengue diagnostic tools (Hunsperger et al., 2009; Peeling et al., 2010). Diagnostic markers to be studied during a dengue infection depend on the time of the infection, the immune response, and the methods and techniques to be used. During the early stages of illness, virus isolation, antigen, and nucleic acid detection can be used to diagnose the infection. Serology is the method of choice for diagnosis at the end of the acute phase of illness. Once an individual is bitten by an infected mosquito, an incubation period of 4–10 days ensues. Viremia is observed 2–3 days before fever onset to 5–6 days after onset. During the viremic period, virus can be isolated and RNA and sNS1 protein can be detected.

Depending on the number of infections, the individual develops a primary, secondary, tertiary, or a quaternary response to infection. Antidengue IgM antibodies are detected in most of cases 5–6 days after onset of fever and usually for 60–90 days, but sometimes up to 6 months (Kuno et al., 1998). In primary infections, IgG antibody begins to appear a few days after the IgM antibody, usually at days 7–9 of fever. Antibody titers continue to rise slowly over a period of weeks and remain detectable probably for a lifetime. In secondary infections, IgG antibody rapidly rises almost immediately after fever onset, with high levels in most patients IgM antibody as well as a high titer of IgG in a single serum are used as markers of a recent dengue infection. The detection of a fourfold IgG or IgM increase or antibody seroconversion in paired sera is considered to be confirmatory for infection. Depending on the time of collection, they can be tested for virus/RNA/antigen detection or for serological studies.

## Acute Dengue Diagnosis

Diagnosis during the acute phase of illness allows early case diagnosis, which may be important for case management. Clinical samples should be collected as early as possible and preferably in the first 3 days of fever onset. Tools available for early diagnosis include

molecular diagnosis such as reverse transcriptase/polymerase chain reaction (RT/PCR) and real-time RT/PCR (allowing confirmation of the infection and serotype identification) as well as NS1 detection. This acute sample is also useful for virus isolation.

## Molecular Diagnosis of Dengue

DENV RNA can be extracted from serum or plasma, as well as from whole blood (WB), blood leukocytes, fresh or paraffin-embedded tissues, mosquitoes, etc. (Klungthong et al., 2007; Wang et al., 2000b). For storage up to 24 hours, specimens can be kept at 2°C–8°C. For longer storage, samples should be frozen at –80°C or at –196°C in liquid nitrogen. Repeated freeze–thaw cycles should be avoided for all RNA viruses. WB samples can also be spotted onto filter paper and viral RNA can then be detected for weeks or even months (Prado et al., 2005).

Nested RT/PCR uses universal dengue primers targeting the conserved C/prM region of the DENV genome for an initial reverse transcription and amplification step, followed by a nested PCR amplification that is serotype-specific (Lanciotti et al., 1992).

The nucleic acid sequence-based amplification assay is a single-step isothermal RNA-specific amplification assay that does not require thermal cycling instrumentation (Jittmittraphap et al., 2006; Wu et al., 2001).

The reverse-transcription loop-mediated isothermal amplification assay is based on the principle of a strand displacement reaction and stem loop structure that amplifies the target under isothermal conditions as well (Lau et al., 2015; Sahni et al., 2013). Recent technologies using mass spectrometry have led to the development of powerful systems that can provide rapid discrimination of biological components in complex mixtures (Gijavanekar et al., 2012; Voge et al., 2016) (Fig. 16.7).

## Antigen Detection

Immunohistochemical methods are using cross-reactive polyclonal or type-specific mAbs against viral structure antigens (Miagostovich et al., 1997) or NS proteins such as NS3 (Balsitis et al., 2009). These antibodies can be conjugated to fluorescein (Boonpucknavig et al., 1981), avidin–biotin peroxidase (Waterman and Monath, 1982), or alkaline phosphatase (Hall et al., 1991).

NS1 exists as cell-associated, cell surface, and extracellular forms. The amount of NS1 in the serum (sNS1) has been shown to directly correlate with viremia (Libraty et al., 2002a). The concentration of sNS1 in plasma is highest during the acute phase of the infection (from day 1

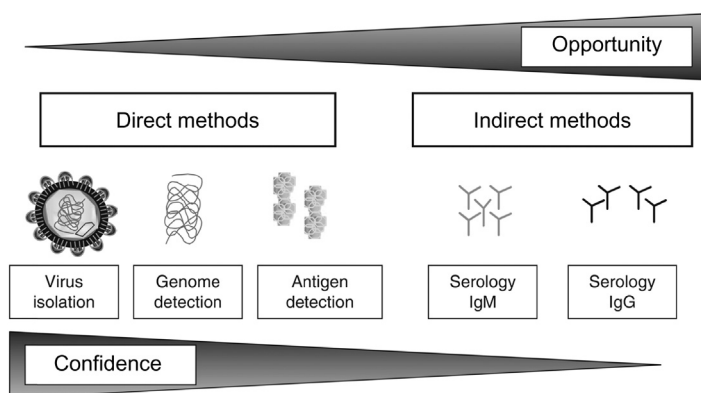

**FIGURE 16.7** Laboratory diagnosis of dengue. *Source: Adapted from Guzman, M.G., Gubler, D.J., Iizquierdo, A., Martinez, E., Halstead, S.B., 2016. Dengue infection. Nat. Rev. Dis. Primers 2, 16055. doi:10.1038/nrdp.2016.55.*

until days 2–4 after onset of fever) and then decreases and is usually not detected after day 14 (Duyen et al., 2011).

## Early and Late Convalescent Diagnosis

Dengue viremia correlates with fever onset, with peak levels at 2–3 days of fever. After this period, viremia as well as sNS1 diminishes, coinciding with antibody development. Serology is the method of choice for late and acute convalescent diagnosis. Specific IgM detection as well as high levels of specific IgG in a monosera allow confirmation of a probable and recent infection, while IgM and/or IgG seroconversion or fourfold increase of IgG titers in paired sera allow infection confirmation (Gubler, 1998a).

The humoral immune dengue response is characterized by the production of antidengue IgM and IgG antibodies. IgM titers in primary infections are significantly higher than in secondary infections (Gubler, 1989b). Currently, IgM antibody capture ELISA in serum samples collected at 5 or 6 days of fever onset constitutes the most important method for serological dengue diagnosis of recent infection and is being widely applied in dengue surveillance (Vazquez et al., 2005).

The HI test is considered the “gold standard” for classifying a case as a primary or secondary infection using paired sera. However, because it is time-consuming and because of the difficulties of obtaining the second serum sample, ELISA is most often chosen (Lukman et al., 2016).

In people suffering a primary dengue infection, the specific IgG antibodies increase slowly at days 7–9 after fever onset, with highest values

at days 15–21. Later on, antibody titer declines, but low levels are detected for a lifetime. In the course of a secondary infection, IgG antibodies rise early during the infection, remaining at high levels for several weeks to months, declining later. These high levels of IgG antibodies during the acute phase of illness allow a presumptive diagnosis (Guzman and Kouri, 2002).

IgG seroconversion (a fourfold increase in titer) is a criterion for dengue diagnosis. Innis et al. applied IgM and IgG capture ELISA to detect both immunoglobulins, defining a primary case by optical density ratios of IgM/IgG  $\geq 1.78$  and a secondary dengue infection by ratios  $< 1.78$ . Kuno et al. using an indirect ELISA, reported IgM/IgG ratios  $> 1.4$  as primary infection and  $< 1.4$  as secondary infection.

The assays used for detecting a past DENV infection are HI, IgG ELISA (Vazquez et al., 1997), and neutralization assay to detect DENV neutralizing antibodies (Alvarez et al., 2008).

## Viral Isolation and Identification

DENVs have been among the most difficult arboviruses to isolate. Virus isolation is considered the gold standard for dengue diagnosis but is only performed in laboratories with an adequate infrastructure and technical expertise. The viruses may be recovered from serum, plasma, peripheral mononuclear cells, and tissues collected at autopsy.

### Mouse Inoculation

The inoculum consists of 0.02 mL of undiluted or 1:10–1:50 of diluted sample in culture medium or phosphate buffer saline (PBS) plus antibiotics and 2% fetal calf serum. Animals should be observed for at least 2–3 weeks. Rapid identification is achieved by indirect immunofluorescent assay, using dengue hyperimmune ascitic fluid, specific dengue mAbs, by RT/PCR or by neutralization assay.

*Mammalian cell lines:* With the development of mammalian cell lines, VERO, BKH21, and LLC-MK<sub>2</sub> were introduced for DENV isolation. These cell lines have a low sensitivity for wild-type viruses. As a result, they are not used for routine DENV isolation, although they are useful for the quantitative plaque assays using solid or semisolid overlays.

*Mosquito inoculation:* The intrathoracic inoculation of adult mosquitoes opened a new sensitive way for DENV isolation. In addition, a method to inoculate mosquito larvae was developed. The mosquito species that have been used include *A. aegypti*, *A. albopictus*, *Toxorhynchites splendens*, and *Toxorhynchites amboinensis* (Gubler et al., 1979).

*Mosquito cell culture:* Mosquito cell lines developed in the 1970s and 1980s provide sensitive systems for DENV isolation. Three cell lines

have commonly been used: AP-61 from *Aedes pseudoscutellaris*, C6/36 from *A. albopictus* and TRA-284 from *T. amboinensis*. Although TRA-284 is the most sensitive cell line, C6/36 is more widely used. Identification can also be done by plaque reduction neutralisation assay (PRNT) and RT/PCR. Viruses may also be identified using serotype-specific mAbs in an indirect immunofluorescence test. An antigen capture enzyme linked immunosorbent assay (ELISA) can be used in the absence of a fluorescence microscope. More recently, flow cytometry as well as NS1 detection have been employed for DENV identification (Jarman et al., 2011; Kao et al., 2001).

## Management of Dengue

Management of suspected dengue patients depends on the clinical illness, of which there are three phases: febrile, critical (leakage), and convalescence. The convalescent phase can be further divided into early (>24–36 hours after shock or >48–60 hours after leakage) and late convalescence (>36 hours after shock or 60 hours after leakage). The three latter disease manifestations, DHF (DHF grades I and II), DSS (DHF grades III and IV), and expanded dengue syndrome, are considered severe because they may lead to complications and death if there is not appropriate and timely management. DHF and DSS patients are different from DF patients in that they have plasma leakage during the critical phase (Halstead and Lum, 2009). The percentage of DHF/DSS patients is also minimal compared to viral-like illness and DF patients, but it is very important that clinician/healthcare personnel diagnose and properly manage these patients in order to prevent shock, severe illness, complications, and death.

Management of patients in the febrile phase is mostly symptomatic and supportive treatment. Dengue patients usually have high sustained fever ranging from 2 to 7 days, mean duration 4–5 days. Common signs and symptoms are severe headache, retro-orbital pain, body ache (myalgia), arthralgia/joint pain, and minor bleeding manifestations, such as petechiae, epistaxis, gum bleeding, and coffee-ground vomiting. Hematemesis and melena are commonly found. Hemoglobinuria is not uncommon, especially in thalassemia, hemoglobinopathy or G-6-PD deficiency patients. Rash (erythematous or maculopapular or petechial) is commonly observed, especially in adult patients. Malaise, poor appetite, nausea/vomiting are common nonspecific signs and symptoms (Vaughn et al., 1997).

Tourniquet test is helpful in diagnosing DHF and DSS. The way to do this test is by the following method. Blood pressure should be measured using an appropriate cuff size. Cuff pressure is increased to half

way between systolic and diastolic pressure for 5 minutes, then released. After 1 minute, or after normal skin circulation is observed, the result can be read. The test is considered positive if there are 310 petechiae/mm<sup>3</sup> (Gubler, 2014).

In case of antipyretics, only paracetamol is recommended to reduce the height of fever, both in children and in adults. Aspirin and NSAID are contraindicated. An antiemetic may be given if the patients have nausea/vomiting. Other supportive and symptomatic medicines may be given according to the clinical signs and symptoms, for example, anticonvulsants, H2-blocker, or proton pump inhibitors. Antibiotic is not indicated if there are no associated bacterial infections. To prevent paracetamol overdose and hepatotoxicity, a tepid sponge should be used to reduce temperature (Kalayanarooj, 2011a).

The following are indications for shock or impending shock:

- Narrowing of pulse pressure to  $\leq 20$  mmHg.
- Hypotension is commonly observed.
- Some patients may present with clinical signs of shock, that is, rapid and weak pulse, delayed capillary refill time ( $> 2$  seconds), cold-clammy skin, or skin mottling with normal blood pressure.
- Rising Hct 320% and thrombocytopenia. Leukopenia and/or thrombocytopenia, poor appetite, clinical deterioration, and significant bleeding during defervescence are all indications for hospitalization (Kalayanarooj, 2011b).

## Management During the Critical Phase

Detect early plasma leakage and volume replacement is indicated. The principle of volume replacement in DHF/DSS patients is to give the minimal amount to maintain effective circulation (intravascular volume). Intravenous fluid has to be similar to the plasma that has been lost into the pleural and peritoneal spaces, for example, normal saline solution (NSS), lactate ringer solution, acetate ringer. The total volume replacement during the critical period is about maintenance (M) + 5% deficit (D) ( $\sim 4.6$  L in adult), and the estimated total duration is  $\sim 36$ – $60$  hours. Intravenous fluid is to be given only in those patients who enter the critical period (Kalayanarooj and Nimmannitya, 2003).

Colloidal solutions should be used for DHF/DSS patients with signs of fluid overload. The colloidal solution to be used is only plasma expander; 10% dextran-40 in NSS. Six percent Heta-starch (Voluven) may be used instead if dextran-40 is not available (Kalayanarooj, 2008).

*Blood/blood component transfusion:* WB is preferred, if available. Plasma has little role in the treatment of uncomplicated DHF/DSS. Hct before and after blood transfusion is a very important measure for



management and follow-up to assess the degree of bleeding. Blood is usually transfused at the rate of 5 mL/kg/h. Platelet transfusion is indicated in those patients who have significant bleeding. Without clinical bleeding, there is no value for platelet transfusion prophylaxis in children regardless of how low the platelet count has fallen. Prophylaxis platelet transfusion may be given when the platelet count is  $<10,000$  cells/mm<sup>3</sup>.

Signs of recovery in most cases are the return of the appetite and an improvement of general conditions. Vital signs are stable. Hct returns to baseline level. WBC returns to normal. Platelet count will return to normal within 3–5 days (80%) in the majority of cases. Increase in urine output is observed. Management of complications that arise as a result of DHF/DSS may be done as per existing protocols (Gubler, 2014).

## Prevention and Control

### ***Dengue Vector Control***

There is little to no effective vector control in many dengue-endemic countries. Even where robust programs are implemented, the disease remains an ongoing risk (Elder and Ballenger-Browning, 2009). Vector control tools are limited in number and not as efficacious as needed. The logistical challenges associated with insecticide applications (adulticides and larvicides), the primary tools used for vector control, result from the need for these agents to come in direct contact with the target vector. In large urban settings the scale and timing of applications are impractical, especially where resources are limited. Furthermore, many protocols show no benefit to disease control. The ineffectiveness of these efforts is due in part to insufficient monitoring and a lack of well-designed programs but is exacerbated by the rise in the level of insecticide resistance.

Community-based source reduction by treating mosquito breeding sites has been tried in a number of locations (Al-Muhandis and Hunter, 2011; Ballenger-Browning and Elder, 2009; Erlanger et al., 2008). However, even the most site-specific community-based campaigns have limitations. These strategies require education of local people and resource-intensive education is needed to reach the large number of people necessary to wage an effective campaign. Community-based campaigns struggle with campaign fatigue.

The following methods and indices are used to surveillance of dengue vector:

- Container index: Percentage of water-holding containers positive for *A. aegypti* larvae or pupae.
- House (or premise) index: Percentage of houses positive for containers with *A. aegypti* larvae or pupae.

- Breteau index: Number of containers positive for *A. aegypti* larvae or pupae per 100 houses.
- Collection of eggs by ovitrap: Ovitrap are small containers set out in the field to collect mosquito eggs.
- Collection of adults using a device is the battery-powered backpack aspirator developed by the American Biophysics Corporation “Standard Professional Light Trap,” the Omni-Directional Fay-Prince trap (with and without CO<sub>2</sub>) and the Centers for Disease Control and Prevention (CDC) Wilton trap or B-G Sentinel trap.

Container surveys are a useful measure of the impact of source reduction efforts. Classic source reduction—the elimination of breeding sites—is conducted by trained inspectors under expert supervision but is highly laborious and ineffective.

Control of larvae uses the following methods such as use of kerosene, diesel oil, and similar products kill larvae and pupae by penetrating the tracheal system and preventing respiration, and monomolecular films of amphoteric surfactants, both natural (soya lecithin) and synthetic, have repeatedly surfaced as a putative control method (Webb and Russell, 2009, 2012).

Insecticides such as DDT were effective against *A. aegypti* with a 24-hour LC<sub>50</sub> for larvae as low as 0.002 ppm. An example of initial success followed by failure is the remarkable success that was obtained in Americas from 1948 to 1952 by “perifocal” treatments: a 3%–5% suspension of DDT applied to the inside and outside of potential breeding sites. By 1952, the species could no longer be found in Argentina, Bolivia, Brazil, British Guiana, Chile, nearly all of Colombia, Ecuador, French Guiana, Mexico, Paraguay, Peru, Uruguay, and the Central American countries, and in 1962, it was declared fully eradicated from 22 countries in the Americas and in 1972 from all Mediterranean countries. Hopes for permanent eradication began to fade, however, with the rapid appearance of resistance to DDT and other organochlorine insecticides.

So when resistance became a major problem organophosphorous larvicides, particularly temephos (Abate), were adopted. Alternatives to temephos are methoprene, a synthetic compound that interferes with insect metamorphosis, and bti, a mosquito-specific, gut-toxic protein suspension derived from the bacterium *Bacillus thuringiensis* serotype H-14. Numerous larvicidal plant extracts have been identified in the laboratory (Giatropoulos et al., 2012; Kovendan et al., 2012, 2013; Mahesh Kumar et al., 2013).

## Biological Control

The concept of using live predators to kill *A. aegypti* is attractive, but although many organisms have been studied, few are in routine use.

Larvivorous fish have been used for many years in cisterns and other large containers (Wu et al., 1987).

Control of adults is being achieved using residual insecticides. Insecticides that are chemically stable can be applied as a residue to surfaces onto which mosquitoes alight. Transient contact with these residues may be sufficient to kill susceptible insects. "Fogging" and other aerosol treatments are used where insecticidal aerosols are widely used for mosquito control. It is generally accepted that the mosquito must be in flight to collide with enough particles to kill it. For this reason, such aerosols are only effective while the particles are airborne for a short time period (Hayes et al., 2006).

Ultralow volume (ULV) aerosols of concentrated insecticide (generally >50% active ingredient) are usually referred to as ULV; the quantity of liquid dispensed can be as little as 50 mL/ha. Indoor space sprays with low volume and ULV aerosols are more effective when applied as indoor space sprays, because adult *A. aegypti* are highly endophilic (Lofgren, 1972).

Protection of water storage containers will eliminate the breeding source and reliable water supply should eliminate the need to store water, but in many communities, storage is a cultural habit, reinforced by failures of the piped supply. Intermittent use of stored water will enhance mosquito production if vessels accumulate leaves and other litter as sources of larval nutrition. Personal protection should be maintained using screens, bed nets, mosquito repellents, and antimosquito sound devices.

So with the failure of these control measures vector control agencies need new affordable, efficacious tools that are safe for people and the environment. Ideally, these tools should be scalable from small villages to large cities, and be socially acceptable and economically and politically sustainable. Furthermore, they should be compatible with current and developing control tools, including vaccines, antiviral drugs, and new insecticides. Genetic-based strategies targeting the vector mosquitoes have the potential to fill these needs and are poised to contribute to future vector control efforts (Alphey et al., 2010; Wilder-Smith et al., 2012).

Genetic strategies are based on the widely accepted theory that disruption of the vector phase of the pathogen life cycle will reduce or eliminate transmission to humans. Disruption can be achieved by eliminating or reducing mosquito densities below transmission thresholds or by making the mosquitoes refractory to virus infection. Novel strategies are being developed based on genetically engineered strains of mosquitoes with design features that maximize utility and safety profiles (Alphey et al., 2011).

Some strategies are designed to be resilient to the immigration of wild mosquitoes originating temporally and spatially. Others have the potential to lower population densities below the transmission threshold of one or more vector-borne pathogens. These genetic-based tools offer access to mosquito breeding sites that would otherwise be inaccessible or cryptic using conventional tools. Genetic approaches in principle should be safer than vector control strategies employing insecticides. Strains can be designed to lower or minimize vector competence for all known pathogens transmitted by the targeted species and increase insecticide susceptibility (Aksoy et al., 2001).

Engineered strains are species-specific, and because *A. aegypti* and *A. albopictus* are invasive species throughout most regions in the world and are preyed upon opportunistically, deployment of these strategies is anticipated to have a negligible impact on ecosystems. Adopting any of these strategies will require site-specific risk assessment prior to release, and monitoring and surveillance during and following releases. Successful genetic strategies will have to be affordable to have a meaningful impact on dengue transmission (Allen et al., 2009; Sinkins and Gould, 2006).

Strategy impact and field properties can be combined as follows:

- Self-limiting population suppression—Periodic releases of genetically engineered mosquitoes suppress population size followed by the elimination of the engineered insects at the cessation of releases.
- Self-sustaining population suppression—Fewer periodic releases needed to suppress population sizes.
- Self-limiting population replacement—Eliminates ability of the mosquitoes to transmit the virus.
- Self-sustaining population replacement—Eliminates ability of the mosquito to transmit the virus.

## Antidengue Drug Development

Current absence of antiviral for dengue has triggered much research in the field of dengue drug discovery and many hypotheses that treatment with an effective antiviral within 48 hours of the onset of the disease may lead to rapid reduction in viral load and limit the development of severe dengue. It may also lead to reduced disease morbidity in DF patients as well as reduced transmission. Few experiments revealed that levels of proinflammatory cytokines and the extent of splenomegaly were also reduced with the drug treatment. Human clinical trials in patients with acute dengue have been conducted with chloroquine (Tricou et al., 2010) and balapiravir (Nguyen et al., 2013).

One of the approaches is to develop drugs that inhibit or modulate host targets that lead to triggering of the inflammation cascade.

Given the complexity of dengue disease pathogenesis, it is critical to establish a set of characteristics that an ideal drug for treatment of DF should possess. Briefly, an effective drug must be active against all four dengue serotypes. It should be an oral drug, because it is the least expensive form to manufacture and distribution, an important consideration for a disease endemic in developing countries. The drug ideally would be effective with once a day dosing, but for acute dengue, a dosing frequency as often as three times a day, if needed to maintain drug levels above a minimally effective concentration, would be acceptable.

The viral processes that can be targeted by antivirals include (1) entry/fusion inhibitors; (2) translation/polyprotein processing inhibitors; (3) replication inhibitors; and (4) packaging/virus maturation inhibitors (Noble et al., 2010).

*Entry inhibitors:* Inhibitors that bind directly to the viral E protein (Schmidt et al., 2010, 2012) or those that can interfere with the steps in the viral and host membrane fusion can be used to effectively block viral entry. Similarly, peptide-based inhibitors that target the stem region of the E protein or therapeutic antibodies that bind to E domain III (DIII) or other parts of the E ectodomain can neutralize the virus in cell-based infections assays. mAbs against E protein domain III that potently neutralized dengue infection that are either serotype-specific or cross-reactive (Beltramello et al., 2010).

## Polyprotein Processing and Translation Inhibitors

Following entry into the cell the dengue viral mRNA is recognized by the host translational machinery to produce the polyprotein that is processed into mature structural and NS proteins by the action of host proteases resident in the ER lumen and the viral NS2B/NS3 protease in the cytoplasm. Active site-directed tetrapeptide and tripeptide inhibitors were synthesized to probe the dynamics of the DENV protease active site with different functional groups that compete with the substrate. These active site serine-trap inhibitors contained either boronic acid, trifluoromethylketone, or aldehyde as the electrophilic warhead (Schuller et al., 2011) and showed potent protease inhibitor activity against DENV-1–4 NS2B/NS3 protease as well as other flaviviral proteases, thus demonstrating that pan-dengue or pan-flaviviral protease inhibitors can be developed (Chu et al., 2015; Dwivedi et al., 2016; Pelliccia et al., 2017; Soares et al., 2018; Tan et al., 2018; Wu et al., 2015). In addition to targeting polyprotein processing, it has been shown that specific translational inhibitors can be developed. Peptide-conjugated

phosphorodiamidate morpholino oligomers that specifically inhibit viral RNA translation or viral RNA synthesis by mimicking the 5' SL or 3' SL, respectively, have been investigated (Holden et al., 2006).

*Replication inhibitors* targeting NS1, NS3 helicase, NS4A, NS4B, NS5 methyl transferase, and NS5 RdRp are being considered and many in vitro studies have proved their efficacy (Abdel-Magid, 2017; da Costa et al., 2013; Pelliccia et al., 2017; Yeo et al., 2015).

*Viral packaging inhibitors* where the interaction between capsid, NS3, and RNA during encapsidation has been alluded to and preventing this important interaction could lead to discovery of new antiviral compounds. Also furin inhibitors provide a strategy for inhibiting virus replication and potent inhibitors that may be broad acting antivirals have been pursued (Becker et al., 2012).

## Dengue Vaccine Development

The potential use of safe and effective dengue vaccines is a very attractive dengue control in addition to vector control. Even if only partially effective, the use of dengue vaccines could be highly beneficial in blunting dengue epidemics, and for increasing population-level immunity to the level where vector control could be more effective (Halstead and Deen, 2002). Dengue vaccines could have beneficial individual-level effects by reducing the probability of infection given exposure to an infected mosquito, that is, vaccine efficacy (VE) for susceptibility to infection, reducing the probability of clinical disease given infection or the probability of severe disease, that is, VE for disease progression, or reducing the probability that an infected vaccinated person will transmit virus to a mosquito that bites him or her, that is, VE for direct transmission.

In addition, with increasing vaccine coverage in a population, vaccines could reduce the overall transmission in the entire community, even to unvaccinated people, and thus have indirect or herd effects. All of these individual-level and community-level vaccine effects need to be taken into account when assessing the potential effectiveness and impact of dengue vaccines (Halstead, 2016).

A potential vaccine must provide a delicate balance between the level of immunogenicity it evokes and the attenuation of DENV pathogenicity. The immunogenicity induced by the vaccine should be such that the level of neutralizing antibodies produced is high enough to provide complete protection against all four serotypes, but also sufficiently attenuated so as not to cause unacceptable pathogenicity (underattenuation) or fail to induce an effective immune response (overattenuation) (Halstead and Aguiar, 2016).

Some of the dengue vaccines that have developed or under development are discussed below.

### ***Yellow Fever Virus as Molecular Backbone Acambis/Sanofi Pasteur Vaccine (CYD)***

DENV vaccine is based on dengue–YF vaccine virus chimeras Chimeric yellow fever virus attenuated 17D (CYD). The operative hypothesis was that the attenuation characteristics of 17D YF vaccine virus will impart similar attenuation attributes to the chimera (Guirakhoo et al., 2002). Chimeric viruses are replicated by the YF RNA polymerase. The CYD tetravalent vaccine is produced by combining the four CYD viruses into a single vaccine preparation, and the vaccine is freeze–dried and contains no adjuvant or preservative.

### ***Takeda/Inviragen/Centers for Disease Control and Prevention Vaccine***

The US CDC developed a tetravalent chimeric dengue vaccine by splicing the prM and E genes of attenuated DENV-1, -3, and -4 into NS RNA of the successfully attenuated DENV-2 16681 PDK-53. The tetravalent vaccine candidate has undergone preclinical testing in mice and nonhuman primates comparing intradermal and subcutaneous routes of delivery. The intradermal delivery of a tetravalent preparation of DENVax (10<sup>5</sup> pfu per DENV-type) produced superior immune responses in cynomolgous monkeys (Osorio et al., 2011a,b).

### ***NIH Vaccine***

They developed vaccines that contained molecularly attenuated viruses, a DENV-4 mutant (DENV-4 2AD30), transcribed from recombinant cDNA, with a 30-nucleotide deletion in the 3' UTR (10,478–10,507), produced lower viremia and slightly decreased neutralizing antibody responses compared with wild-type DENV-4 (Bray et al., 1996). A similar rDENV-1 D30 construct was made and evaluated in animal models and found to be attenuated and immunogenic. To make recombinant (r) DENV-2/4 D30(ME), the prM and E structural proteins of the DEN4 candidate vaccine rDENV-4 D30 were those of DENV-2 NGC. Yet another approach uses a capsid-deleted WNV vector to produce DENV pseudoinfectious derivatives (Suzuki et al., 2009). The DENV-WNV chimeras are expected to retain the wild-type WNV attribute of high replicative efficiency enhancing the productive potential of such an approach.

Another vaccine candidate, rDENV-3/4 D30(ME), was made that contains the membrane (M) precursor and envelope (E) genes of DENV-3 inserted into DENV-4 with a 30-nucleotide deletion in the 3' UTR.



***Tetravalent NIH Vaccine***

National Institute of Health (NIH) has chosen to generate tetravalent dengue vaccines either by separately introducing 3' terminus changes into each of the four DENV or by making structural gene chimeras, including all four sets of dengue antigens or by using a combination of these approaches.

***Live-Attenuated Vaccines: US FDA Vaccine***

Investigators at the Center for Biologics Evaluation and Research at the US FDA created a chimeric virus combining a DENV-2 with the terminal 3' stem and loop structure of WNV. This virus grew normally in mammalian LLC-MK<sub>2</sub> cells but was severely restricted for growth in C6/36 insect cells and was designated "mutant F" or "mutF." And in rhesus monkey, immune responses were similar to those of the wild-type virus (Li et al., 2014; Yang et al., 2016).

***University of Hawaii Vaccine***

United States Armed Forces Epidemiology Board initiated a cooperative scientific effort to develop vaccines against the four DENV. Workers at the Department of Tropical Medicine and Medical Microbiology of the University of Hawaii Medical School anticipated this effort by screening tissue culture-passaged wild-type DENV-1, -2, and -4 and mouse-passaged DENV-3 in cell systems that had been used to propagate viral vaccines licensed for use in the United States. These included WI-38 continuous human embryo lung, primary chick and duck embryo fibroblasts, primary rabbit kidney cells, primary dog (PDK) kidney cells and primary African green monkey kidney cells. Serial passage of different wild-type DENV (2 DENV-1, 2 DENV-2, and 3 DENV-4) resulted in phenotypic changes. These phenotypic changes were used successfully to identify human dengue vaccine candidates at Mahidol University and when this vaccine was introduced to human trials, all human volunteers at Thailand developed classical DF, and this result led to the abandonment of further development of the Mahidol LAV (Goh et al., 2016; Huang et al., 2003; Rabablt and Yoksan, 2009).

***Vectored Vaccines***

With the advent of genetic engineering, many attempts have been made to develop vaccines by inserting genes for structural proteins in replicative carriers. The virus most commonly used vector early in this era was vaccinia virus (Deubel et al., 1988; Men et al., 2000).

### **Measles Virus as Vector**

In this technology, genes coding for 100 amino acids of the envelope domain III (EDIII) fused to 40 amino acids of the ectodomain of the membrane protein (ectoM) from DENV-1 were inserted into the genome of the Schwarz strain of measles vaccine (Brandler et al., 2007, 2010).

### **Adenovirus as Vector**

At least two laboratories have developed second-generation adenovirus complex vectors to express and present dengue antigen. Two constructs were developed, one with prM and E genes of DENV-1 and -2, and the other with the same genes of DENV-3 and -4. These vaccines were mixed and given to a large group of rhesus monkeys. Twenty percent of animals raised tetraivalent-neutralizing antibodies following one dose, but 100% developed high-titered neutralizing antibodies when boosted with a second dose 3 months later. When challenged with live DENV-1–4 at 1 or 6 months, all animals were protected against DENV-1–3, with moderate protection to DENV-4 challenge (Holman et al., 2007; Raviprakash et al., 2008).

### **Alphavirus Vector**

The University of North Carolina has developed a vaccine in which DENV E protein is produced by a Venezuelan encephalitis virus replicon (VRP). A gene cassette encoding envelope proteins (E proteins) prM and E from mouse-adapted DENV-2 strain NGC was cloned into a VRP that programmed proper in vitro expression and processing of DENV-2 E proteins on infection of Vero cells. Immunization in BALB/c mice resulted in high levels of DENV-specific serum IgG and significant levels of neutralizing antibodies (Khalil et al., 2014; White et al., 2007, 2013).

### **Walter Reed Army Institute of Research Vaccine**

The Walter Reed Army Institute of Research also developed a tetraivalent live-attenuated dengue vaccine based on serial passage of wild-type DENV in PDK cells. Among the selected passage levels, the seroconversion rates were 100%, 92%, 46%, and 58% for a single dose of DENV-1, -2, -3, and -4, respectively (Kanesa-Thanan et al., 2003).

### **Recombinant Subunit Vaccines**

T- and B-cell epitopes have been mapped on DENV structural proteins such as EDIII and NS proteins (Kurane et al., 1998). The right combination of epitopes expressed in protein subunit vaccines could be the basis for an effective and safe vaccine at moderate cost. Structural and NS DENV proteins have been produced in adequate amounts in

many expression systems including *Escherichia coli* (Simmons et al., 1998) baculovirus in *Spodoptera frugiperda* insect cells and *Drosophila* cells (Velzing et al., 1999), yeast (Tan et al., 2007), and vaccinia virus (Men et al., 2000).

### **DNA Vaccines**

DNA vaccines consist of a plasmid or plasmids containing dengue genes reproduced to high copy number in bacteria such as *E. coli* (Whalen, 1996). The plasmid contains a eukaryotic promoter and termination sequence to drive transcription in the vaccine recipient. The transcribed RNA is translated to produce proteins to be processed and presented to the immune system in the context of MHC molecules. Additional genes such as intracellular trafficking and immunostimulatory sequences can be added to the plasmid. The target organism's immune system recognizes the expressed antigen, and generates antibodies and/or cell-mediated immune responses. DNA-based vaccine constructs can be modified without the need for subsequent viability as required when working with infectious clones. DNA vaccines afford numerous advantages over conventional vaccines, including ease of production, stability, and transport at room temperature, and they provide a possibility to immunize against multiple pathogens with a single vaccine. Workers at the US Naval Medical Research Institute evaluated two eukaryotic plasmid expression vectors (pkCMVint-Polyli and pVR1012,) expressing the PrM protein and 92% of the E protein for DENV-2 (New Guinea C strain). Both constructs induced neutralizing antibody in all mice (Kochel et al., 1997). But various improvements to the original construct have been made, and animal trials are underway to evaluate their immunogenicity and efficacy.

### **References**

- Abdel-Magid, A.F., 2017. Viral replication inhibitors may treat the dengue virus infections. ACS Med. Chem. Lett. 8 (1), 14–16. Available from: <https://doi.org/10.1021/acsmchemlett.6b00513>.
- Adam, I., Jumaa, A.M., Elbashir, H.M., Karsany, M.S., 2010. Maternal and perinatal outcomes of dengue in PortSudan, Eastern Sudan. Virol. J. 7, 153. Available from: <https://doi.org/10.1186/1743-422X-7-153>.
- Adams, M.J., Lefkowitz, E.J., King, A.M.Q., Harrach, B., Harrison, R.L., Knowles, N.J., et al., 2017. Changes to taxonomy and the International Code of Virus Classification and Nomenclature ratified by the International Committee on Taxonomy of Viruses (2017). Arch. Virol. 162 (8), 2505–2538. Available from: <https://doi.org/10.1007/s00705-017-3358-5>.
- Aksoy, S., Maudlin, I., Dale, C., Robinson, A.S., O'Neill, S.L., 2001. Prospects for control of African trypanosomiasis by tsetse vector manipulation. Trends Parasitol. 17 (1), 29–35.

- Allen, R.A., Lewis, C.N., Meisch, M.V., Dame, D.A., 2009. Comparison of three residential mosquito traps against riceland mosquitoes in southeast Arkansas. *J. Am. Mosq. Control. Assoc.* 25 (1), 110–112. Available from: <https://doi.org/10.2987/08-5805.1>.
- Al-Muhandis, N., Hunter, P.R., 2011. The value of educational messages embedded in a community-based approach to combat dengue fever: a systematic review and meta regression analysis. *PLoS Negl. Trop. Dis.* 5 (8), e1278. Available from: <https://doi.org/10.1371/journal.pntd.0001278>.
- Alphay, L., Benedict, M., Bellini, R., Clark, G.G., Dame, D.A., Service, M.W., et al., 2010. Sterile-insect methods for control of mosquito-borne diseases: an analysis. *Vector Borne Zoonotic Dis.* 10 (3), 295–311. Available from: <https://doi.org/10.1089/vbz.2009.0014>.
- Alphay, N., Bonsall, M.B., Alphay, L., 2011. Modeling resistance to genetic control of insects. *J. Theor. Biol.* 270 (1), 42–55. Available from: <https://doi.org/10.1016/j.jtbi.2010.11.016>.
- Alvarez, D.E., De Lella Ezcurra, A.L., Fucito, S., Gamarnik, A.V., 2005a. Role of RNA structures present at the 3' UTR of dengue virus on translation, RNA synthesis, and viral replication. *Virology* 339 (2), 200–212. Available from: <https://doi.org/10.1016/j.virol.2005.06.009>.
- Alvarez, D.E., Lodeiro, M.F., Luduena, S.J., Pietrasanta, L.I., Gamarnik, A.V., 2005b. Long-range RNA-RNA interactions circularize the dengue virus genome. *J. Virol.* 79 (11), 6631–6643. Available from: <https://doi.org/10.1128/JVI.79.11.6631-6643.2005>.
- Alvarez, D.E., Lodeiro, M.F., Filomatori, C.V., Fucito, S., Mondotte, J.A., Gamarnik, A.V., 2006. Structural and functional analysis of dengue virus RNA. *Novartis Found. Symp.* 277, 120–132. discussion 132-125, 251-123.
- Alvarez, M., Pavon-Oro, A., Rodriguez-Roche, R., Bernardo, L., Morier, L., Sanchez, L., et al., 2008. Neutralizing antibody response variation against dengue 3 strains. *J. Med. Virol.* 80 (10), 1783–1789. Available from: <https://doi.org/10.1002/jmv.21234>.
- Amarasinghe, A., Kuritsk, J.N., Letson, G.W., Margolis, H.S., 2011. Dengue virus infection in Africa. *Emerg. Infect. Dis.* 17 (8), 1349–1354. Available from: <https://doi.org/10.3201/eid1708.101515>.
- Amorim, J.H., Diniz, M.O., Cariri, F.A., Rodrigues, J.F., Bizerra, R.S., Goncalves, A.J., et al., 2012. Protective immunity to DENV2 after immunization with a recombinant NS1 protein using a genetically detoxified heat-labile toxin as an adjuvant. *Vaccine* 30 (5), 837–845. Available from: <https://doi.org/10.1016/j.vaccine.2011.12.034>.
- Anders, K.L., Nguyet, N.M., Chau, N.V., Hung, N.T., Thuy, T.T., Lien le, B., et al., 2011. Epidemiological factors associated with dengue shock syndrome and mortality in hospitalized dengue patients in Ho Chi Minh City, Vietnam. *Am. J. Trop. Med. Hyg.* 84 (1), 127–134. Available from: <https://doi.org/10.4269/ajtmh.2011.10-0476>.
- Anderson, J.R., Rico-Hesse, R., 2006. *Aedes aegypti* vectorial capacity is determined by the infecting genotype of dengue virus. *Am. J. Trop. Med. Hyg.* 75 (5), 886–892.
- Anglero-Rodriguez, Y.I., Pantoja, P., Sariol, C.A., 2014. Dengue virus subverts the interferon induction pathway via NS2B/3 protease-IkappaB kinase epsilon interaction. *Clin. Vaccine Immunol.* 21 (1), 29–38. Available from: <https://doi.org/10.1128/CVI.00500-13>.
- Ansarah-Sobrinho, C., Nelson, S., Jost, C.A., Whitehead, S.S., Pierson, T.C., 2008. Temperature-dependent production of pseudoinfectious dengue reporter virus particles by complementation. *Virology* 381 (1), 67–74. Available from: <https://doi.org/10.1016/j.virol.2008.08.021>.
- Aoki, C., Hidari, K.I., Itonori, S., Yamada, A., Takahashi, N., Kasama, T., et al., 2006. Identification and characterization of carbohydrate molecules in mammalian cells recognized by dengue virus type 2. *J. Biochem.* 139 (3), 607–614. Available from: <https://doi.org/10.1093/jb/mvj067>.

- Ashour, J., Laurent-Rolle, M., Shi, P.Y., Garcia-Sastre, A., 2009. NS5 of dengue virus mediates STAT2 binding and degradation. *J. Virol.* 83 (11), 5408–5418. Available from: <https://doi.org/10.1128/JVI.02188-08>.
- Ashour, J., Morrison, J., Laurent-Rolle, M., Belicha-Villanueva, A., Plumlee, C.R., Bernal-Rubio, D., et al., 2010. Mouse STAT2 restricts early dengue virus replication. *Cell Host Microbe* 8 (5), 410–421. Available from: <https://doi.org/10.1016/j.chom.2010.10.007>.
- Attoui, H., Billoir, F., Biagini, P., Cantaloube, J.F., de Chesse, R., de Micco, P., et al., 2000. Sequence determination and analysis of the full-length genome of Colorado tick fever virus, the type species of genus *Coltivirus* (family Reoviridae). *Biochem. Biophys. Res. Commun.* 273 (3), 1121–1125. Available from: <https://doi.org/10.1006/bbrc.2000.3057>.
- Avirutnan, P., Punyadee, N., Noisakran, S., Komoltri, C., Thiemmecca, S., Auethavornanan, K., et al., 2006. Vascular leakage in severe dengue virus infections: a potential role for the nonstructural viral protein NS1 and complement. *J. Infect. Dis.* 193 (8), 1078–1088. Available from: <https://doi.org/10.1086/500949>.
- Avirutnan, P., Zhang, L., Punyadee, N., Manuyakorn, A., Puttikhunt, C., Kasinrer, W., et al., 2007. Secreted NS1 of dengue virus attaches to the surface of cells via interactions with heparan sulfate and chondroitin sulfate. *PLoS Pathog.* 3 (11), e183. Available from: <https://doi.org/10.1371/journal.ppat.0030183>.
- Ballenger-Browning, K.K., Elder, J.P., 2009. Multi-modal *Aedes aegypti* mosquito reduction interventions and dengue fever prevention. *Trop. Med. Int. Health* 14 (12), 1542–1551. Available from: <https://doi.org/10.1111/j.1365-3156.2009.02396.x>.
- Balmaseda, A., Hammond, S.N., Perez, L., Tellez, Y., Saborio, S.I., Mercado, J.C., et al., 2006. Serotype-specific differences in clinical manifestations of dengue. *Am. J. Trop. Med. Hyg.* 74 (3), 449–456.
- Balsitis, S.J., Coloma, J., Castro, G., Alava, A., Flores, D., McKerrow, J.H., et al., 2009. Tropism of dengue virus in mice and humans defined by viral nonstructural protein 3-specific immunostaining. *Am. J. Trop. Med. Hyg.* 80 (3), 416–424.
- Balsitis, S.J., Williams, K.L., Lachica, R., Flores, D., Kyle, J.L., Mehlhop, E., et al., 2010. Lethal antibody enhancement of dengue disease in mice is prevented by Fc modification. *PLoS Pathog.* 6 (2), e1000790. Available from: <https://doi.org/10.1371/journal.ppat.1000790>.
- Baly, A., Toledo, M.E., Rodriguez, K., Benitez, J.R., Rodriguez, M., Boelaert, M., et al., 2012. Costs of dengue prevention and incremental cost of dengue outbreak control in Guantanamo, Cuba. *Trop. Med. Int. Health* 17 (1), 123–132. Available from: <https://doi.org/10.1111/j.1365-3156.2011.02881.x>.
- Banerjee, S., Aditya, G., Saha, G.K., 2015. Household wastes as larval habitats of dengue vectors: comparison between urban and rural areas of Kolkata, India. *PLoS One* 10 (10), e0138082. Available from: <https://doi.org/10.1371/journal.pone.0138082>.
- Bartholomeusz, A., Tomlinson, E., Wright, P.J., Birch, C., Locarnini, S., Weigold, H., et al., 1994. Use of a flavivirus RNA-dependent RNA polymerase assay to investigate the antiviral activity of selected compounds. *Antiviral Res.* 24 (4), 341–350.
- Bashyam, H.S., Green, S., Rothman, A.L., 2006. Dengue virus-reactive CD8+ T cells display quantitative and qualitative differences in their response to variant epitopes of heterologous viral serotypes. *J. Immunol.* 176 (5), 2817–2824.
- Beatty, M.E., Stone, A., Fitzsimons, D.W., Hanna, J.N., Lam, S.K., Vong, S., et al., 2010. Best practices in dengue surveillance: a report from the Asia-Pacific and Americas Dengue Prevention Boards. *PLoS Negl. Trop. Dis.* 4 (11), e890. Available from: <https://doi.org/10.1371/journal.pntd.0000890>.
- Becker, G.L., Lu, Y., Hards, K., Strehlow, B., Levesque, C., Lindberg, I., et al., 2012. Highly potent inhibitors of proprotein convertase furin as potential drugs for treatment of infectious diseases. *J. Biol. Chem.* 287 (26), 21992–22003. Available from: <https://doi.org/10.1074/jbc.M111.332643>.

- Beltramello, M., Williams, K.L., Simmons, C.P., Macagno, A., Simonelli, L., Quyen, N.T., et al., 2010. The human immune response to dengue virus is dominated by highly cross-reactive antibodies endowed with neutralizing and enhancing activity. *Cell Host Microbe* 8 (3), 271–283. Available from: <https://doi.org/10.1016/j.chom.2010.08.007>.
- Benarroch, D., Selisko, B., Locatelli, G.A., Maga, G., Romette, J.L., Canard, B., 2004. The RNA helicase, nucleotide 5'-triphosphatase, and RNA 5'-triphosphatase activities of dengue virus protein NS3 are Mg<sup>2+</sup>-dependent and require a functional Walker B motif in the helicase catalytic core. *Virology* 328 (2), 208–218. Available from: <https://doi.org/10.1016/j.virol.2004.07.004>.
- Bennett, S.N., 2014. Taxonomy and evolutionary relationship of flaviviruses. In: Ooi, E.E., Gubler, D.J., Vasudevan, S., Farrar, J. (Eds.), *Dengue and Dengue Hemorrhagic Fever*, Vol. 322–333. CAB International.
- Bernardo, L., Yndart, A., Vazquez, S., Morier, L., Guzman, M.G., 2005. Antibody responses to Asian and American genotypes of dengue 2 virus in immunized mice. *Clin. Diagn. Lab. Immunol.* 12 (2), 361–362. Available from: <https://doi.org/10.1128/CDLI.12.2.361-362.2005>.
- Bhatia, R., Dash, A.P., Sunyoto, T., 2013. Changing epidemiology of dengue in South-East Asia. *WHO South East Asia J. Public Health* 2 (1), 23–27. Available from: <https://doi.org/10.4103/2224-3151.115830>.
- Bhatt, S., Gething, P.W., Brady, O.J., Messina, J.P., Farlow, A.W., Moyes, C.L., et al., 2013. The global distribution and burden of dengue. *Nature* 496 (7446), 504–507. Available from: <https://doi.org/10.1038/nature12060>.
- Bhattacharya, M.K., Maitra, S., Ganguly, A., Bhattacharya, A., Sinha, A., 2013. Dengue: a growing menace—a snapshot of recent facts, figures & remedies. *Int. J. Biomed. Sci.* 9 (2), 61–67.
- Bhuvanakantham, R., Chong, M.K., Ng, M.L., 2009. Specific interaction of capsid protein and importin-alpha/beta influences West Nile virus production. *Biochem. Biophys. Res. Commun.* 389 (1), 63–69. Available from: <https://doi.org/10.1016/j.bbrc.2009.08.108>.
- Biswas, H.H., Ortega, O., Gordon, A., Standish, K., Balmaseda, A., Kuan, G., et al., 2012. Early clinical features of dengue virus infection in Nicaraguan children: a longitudinal analysis. *PLoS Negl. Trop. Dis.* 6 (3), e1562. Available from: <https://doi.org/10.1371/journal.pntd.0001562>.
- Bokisch, V.A., Top Jr, F.H., Russell, P.K., Dixon, F.J., Muller-Eberhard, H.J., 1973. The potential pathogenic role of complement in dengue hemorrhagic shock syndrome. *N. Engl. J. Med.* 289 (19), 996–1000. Available from: <https://doi.org/10.1056/NEJM197311082891902>.
- Boonnak, K., Slike, B.M., Burgess, T.H., Mason, R.M., Wu, S.J., Sun, P., et al., 2008. Role of dendritic cells in antibody-dependent enhancement of dengue virus infection. *J. Virol.* 82 (8), 3939–3951. Available from: <https://doi.org/10.1128/JVI.02484-07>.
- Boonpucknavig, S., Vuttiviroj, O., Boonpucknavig, V., 1981. Infection of young adult mice with dengue virus type 2. *Trans. R. Soc. Trop. Med. Hyg.* 75 (5), 647–653.
- Brandler, S., Lucas-Hourani, M., Moris, A., Frenkiel, M.P., Combredet, C., Fevrier, M., et al., 2007. Pediatric measles vaccine expressing a dengue antigen induces durable serotype-specific neutralizing antibodies to dengue virus. *PLoS Negl. Trop. Dis.* 1 (3), e96. Available from: <https://doi.org/10.1371/journal.pntd.0000096>.
- Brandler, S., Ruffie, C., Najburg, V., Frenkiel, M.P., Bedouelle, H., Despres, P., et al., 2010. Pediatric measles vaccine expressing a dengue tetravalent antigen elicits neutralizing antibodies against all four dengue viruses. *Vaccine* 28 (41), 6730–6739. Available from: <https://doi.org/10.1016/j.vaccine.2010.07.073>.
- Bray, M., Men, R., Lai, C.J., 1996. Monkeys immunized with intertypic chimeric dengue viruses are protected against wild-type virus challenge. *J. Virol.* 70 (6), 4162–4166.

- Bressanelli, S., Stiasny, K., Allison, S.L., Stura, E.A., Duquerroy, S., Lescar, J., et al., 2004. Structure of a flavivirus envelope glycoprotein in its low-pH-induced membrane fusion conformation. *EMBO J.* 23 (4), 728–738. Available from: <https://doi.org/10.1038/sj.emboj.7600064>.
- Calisher, C.H., Karabatsos, N., Dalrymple, J.M., Shope, R.E., Porterfield, J.S., Westaway, E. G., et al., 1989. Antigenic relationships between flaviviruses as determined by cross-neutralization tests with polyclonal antisera. *J. Gen. Virol.* 70 (Pt 1), 37–43. Available from: <https://doi.org/10.1099/0022-1317-70-1-37>.
- Cardosa, M.J., Porterfield, J.S., Gordon, S., 1983. Complement receptor mediates enhanced flavivirus replication in macrophages. *J. Exp. Med.* 158 (1), 258–263.
- Carlos, C.C., Oishi, K., Cinco, M.T., Mapua, C.A., Inoue, S., Cruz, D.J., et al., 2005. Comparison of clinical features and hematologic abnormalities between dengue fever and dengue hemorrhagic fever among children in the Philippines. *Am. J. Trop. Med. Hyg.* 73 (2), 435–440.
- Chen, Y., Maguire, T., Hileman, R.E., Fromm, J.R., Esko, J.D., Linhardt, R.J., et al., 1997. Dengue virus infectivity depends on envelope protein binding to target cell heparan sulfate. *Nat. Med.* 3 (8), 866–871.
- Chen, S.T., Lin, Y.L., Huang, M.T., Wu, M.F., Cheng, S.C., Lei, H.Y., et al., 2008a. CLEC5A is critical for dengue-virus-induced lethal disease. *Nature* 453 (7195), 672–676. Available from: <https://doi.org/10.1038/nature07013>.
- Chen, W., Gao, N., Wang, J.L., Tian, Y.P., Chen, Z.T., An, J., 2008b. Vimentin is required for dengue virus serotype 2 infection but microtubules are not necessary for this process. *Arch. Virol.* 153 (9), 1777–1781. Available from: <https://doi.org/10.1007/s00705-008-0183-x>.
- Cheng, H.J., Lin, C.F., Lei, H.Y., Liu, H.S., Yeh, T.M., Luo, Y.H., et al., 2009. Proteomic analysis of endothelial cell autoantigens recognized by anti-dengue virus nonstructural protein 1 antibodies. *Exp. Biol. Med.* (Maywood) 234 (1), 63–73. Available from: <https://doi.org/10.3181/0805-RM-147>.
- Chu, J.J., Lee, R.C., Ang, M.J., Wang, W.L., Lim, H.A., Wee, J.L., et al., 2015. Antiviral activities of 15 dengue NS2B-NS3 protease inhibitors using a human cell-based viral quantification assay. *Antiviral Res.* 118, 68–74. Available from: <https://doi.org/10.1016/j.antiviral.2015.03.010>.
- Cleaves, G.R., Dubin, D.T., 1979. Methylation status of intracellular dengue type 2 40 S RNA. *Virology* 96 (1), 159–165.
- Clifford, C.M., Yunker, C.E., Thomas, L.A., Easton, E.R., Corwin, D., 1971. Isolation of a group B arbovirus from *Ixodes uriae* collected on Three Arch Rocks National Wildlife Refuge, Oregon. *Am. J. Trop. Med. Hyg.* 20 (3), 461–468.
- Clyde, K., Kyle, J.L., Harris, E., 2006. Recent advances in deciphering viral and host determinants of dengue virus replication and pathogenesis. *J. Virol.* 80 (23), 11418–11431. Available from: <https://doi.org/10.1128/JVI.01257-06>.
- Coffey, L.L., Mertens, E., Brehin, A.C., Fernandez-Garcia, M.D., Amara, A., Despres, P., et al., 2009. Human genetic determinants of dengue virus susceptibility. *Microbes Infect.* 11 (2), 143–156. Available from: <https://doi.org/10.1016/j.micinf.2008.12.006>.
- Cologna, R., Rico-Hesse, R., 2003. American genotype structures decrease dengue virus output from human monocytes and dendritic cells. *J. Virol.* 77 (7), 3929–3938.
- Cook, A.R., Carrasco, L.R., Lee, V.J., Ooi, E.E., Chen, M.L., Lye, D.C., et al., 2012. Higher risk of infection with dengue at the weekend among male Singaporeans. *Am. J. Trop. Med. Hyg.* 87 (6), 1116–1118. Available from: <https://doi.org/10.4269/ajtmh.2012.11-0648>.
- Costa, S.M., Freire, M.S., Alves, A.M., 2006. DNA vaccine against the non-structural 1 protein (NS1) of dengue 2 virus. *Vaccine* 24 (21), 4562–4564. Available from: <https://doi.org/10.1016/j.vaccine.2005.08.022>.



- Crabtree, M.B., Kinney, R.M., Miller, B.R., 2005. Deglycosylation of the NS1 protein of dengue 2 virus, strain 16681: construction and characterization of mutant viruses. *Arch. Virol.* 150 (4), 771–786. Available from: <https://doi.org/10.1007/s00705-004-0430-8>.
- da Costa, E.C., Amorim, R., da Silva, F.C., Rocha, D.R., Papa, M.P., de Arruda, L.B., et al., 2013. Synthetic 1,4-pyran naphthoquinones are potent inhibitors of dengue virus replication. *PLoS One* 8 (12), e82504. Available from: <https://doi.org/10.1371/journal.pone.0082504>.
- D'Arcy, A., Chaillet, M., Schiering, N., Villard, F., Lim, S.P., Lefevre, P., et al., 2006. Purification and crystallization of dengue and West Nile virus NS2B-NS3 complexes. *Acta Crystallogr. Sect. F. Struct. Biol. Cryst. Commun.* 62 (Pt 2), 157–162. Available from: <https://doi.org/10.1107/S1744309106001199>.
- Davis, J.S., Bourke, P., 2004. Rhabdomyolysis associated with dengue virus infection. *Clin. Infect. Dis.* 38 (10), e109–111. Available from: <https://doi.org/10.1086/392510>.
- de Alwis, R., Beltramello, M., Messer, W.B., Sukupolvi-Petty, S., Wahala, W.M., Kraus, A., et al., 2011. In-depth analysis of the antibody response of individuals exposed to primary dengue virus infection. *PLoS Negl. Trop. Dis.* 5 (6), e1188. Available from: <https://doi.org/10.1371/journal.pntd.0001188>.
- Dejnirattisai, W., Duangchinda, T., Lin, C.L., Vasanawathana, S., Jones, M., Jacobs, M., et al., 2008. A complex interplay among virus, dendritic cells, T cells, and cytokines in dengue virus infections. *J. Immunol.* 181 (9), 5865–5874.
- Dejnirattisai, W., Jumnainsong, A., Onsirirakul, N., Fitton, P., Vasanawathana, S., Limpitikul, W., et al., 2010. Cross-reacting antibodies enhance dengue virus infection in humans. *Science* 328 (5979), 745–748. Available from: <https://doi.org/10.1126/science.1185181>.
- Della-Porta, A.J., Westaway, E.G., 1978. A multi-hit model for the neutralization of animal viruses. *J. Gen. Virol.* 38 (1), 1–19. Available from: <https://doi.org/10.1099/0022-1317-38-1-1>.
- Descloux, E., Cao-Lormeau, V.M., Roche, C., De Lamballerie, X., 2009. Dengue 1 diversity and microevolution, French Polynesia 2001-2006: connection with epidemiology and clinics. *PLoS Negl. Trop. Dis.* 3 (8), e493. Available from: <https://doi.org/10.1371/journal.pntd.0000493>.
- Deubel, V., Kinney, R.M., Esposito, J.J., Cropp, C.B., Vorndam, A.V., Monath, T.P., et al., 1988. Dengue 2 virus envelope protein expressed by a recombinant vaccinia virus fails to protect monkeys against dengue. *J. Gen. Virol.* 69 (Pt 8), 1921–1929. Available from: <https://doi.org/10.1099/0022-1317-69-8-1921>.
- Duangchinda, T., Dejnirattisai, W., Vasanawathana, S., Limpitikul, W., Tangthawornchaikul, N., Malasit, P., et al., 2010. Immunodominant T-cell responses to dengue virus NS3 are associated with DHF. *Proc. Natl. Acad. Sci. U.S.A.* 107 (39), 16922–16927. Available from: <https://doi.org/10.1073/pnas.1010867107>.
- Duarte, H.H., Franca, E.B., 2006. Data quality of dengue epidemiological surveillance in Belo Horizonte, Southeastern Brazil. *Rev. Saude Publica* 40 (1), 134–142. S0034-89102006000100021.
- Dulbecco, R., Vogt, M., Strickland, A.G., 1956. A study of the basic aspects of neutralization of two animal viruses, western equine encephalitis virus and poliomyelitis virus. *Virology* 2 (2), 162–205.
- Duyen, H.T., Ngoc, T.V., Ha do, T., Hang, V.T., Kieu, N.T., Young, P.R., et al., 2011. Kinetics of plasma viremia and soluble nonstructural protein 1 concentrations in dengue: differential effects according to serotype and immune status. *J. Infect. Dis.* 203 (9), 1292–1300. Available from: <https://doi.org/10.1093/infdis/jir014>.
- Dwivedi, V.D., Tripathi, I.P., Bharadwaj, S., Kaushik, A.C., Mishra, S.K., 2016. Identification of new potent inhibitors of dengue virus NS3 protease from traditional

- Chinese medicine database. *Virusdisease* 27 (3), 220–225. Available from: <https://doi.org/10.1007/s13337-016-0328-6>.
- Egloff, M.P., Benarroch, D., Selisko, B., Romette, J.L., Canard, B., 2002. An RNA cap (nucleoside-2'-O)-methyltransferase in the flavivirus RNA polymerase NS5: crystal structure and functional characterization. *EMBO J.* 21 (11), 2757–2768. Available from: <https://doi.org/10.1093/emboj/21.11.2757>.
- Egloff, M.P., Decroly, E., Malet, H., Selisko, B., Benarroch, D., Ferron, F., et al., 2007. Structural and functional analysis of methylation and 5'-RNA sequence requirements of short capped RNAs by the methyltransferase domain of dengue virus NS5. *J. Mol. Biol.* 372 (3), 723–736. Available from: <https://doi.org/10.1016/j.jmb.2007.07.005>.
- Ehrenkrantz, N.J., Ventura, A.K., Cuadrado, R.R., Pond, W.L., Porter, J.E., 1971. Pandemic dengue in Caribbean countries and the southern United States—past, present and potential problems. *N. Engl. J. Med.* 285 (26), 1460–1469. Available from: <https://doi.org/10.1056/NEJM197112232852606>.
- Elder, J.P., Ballenger-Browning, K., 2009. Community involvement in dengue vector control. *BMJ* 338, b1023. Available from: <https://doi.org/10.1136/bmj.b1023>.
- Endy, T.P., Chunsuttiwat, S., Nisalak, A., Libraty, D.H., Green, S., Rothman, A.L., et al., 2002. Epidemiology of inapparent and symptomatic acute dengue virus infection: a prospective study of primary school children in Kamphaeng Phet, Thailand. *Am. J. Epidemiol.* 156 (1), 40–51.
- Erlanger, T.E., Keiser, J., Utzinger, J., 2008. Effect of dengue vector control interventions on entomological parameters in developing countries: a systematic review and meta-analysis. *Med. Vet. Entomol.* 22 (3), 203–221. Available from: <https://doi.org/10.1111/j.1365-2915.2008.00740.x>.
- Falgout, B., Pethel, M., Zhang, Y.M., Lai, C.J., 1991. Both nonstructural proteins NS2B and NS3 are required for the proteolytic processing of dengue virus nonstructural proteins. *J. Virol.* 65 (5), 2467–2475.
- Ferreira, G.L., 2012. Global dengue epidemiology trends. *Rev. Inst. Med. Trop. Sao Paulo* 54 (Suppl. 18), S5–6.
- Filomatori, C.V., Lodeiro, M.F., Alvarez, D.E., Samsa, M.M., Pietrasanta, L., Gamarnik, A.V., 2006. A 5' RNA element promotes dengue virus RNA synthesis on a circular genome. *Genes Dev.* 20 (16), 2238–2249. Available from: <https://doi.org/10.1101/gad.1444206>.
- Filomatori, C.V., Iglesias, N.G., Villordo, S.M., Alvarez, D.E., Gamarnik, A.V., 2011. RNA sequences and structures required for the recruitment and activity of the dengue virus polymerase. *J. Biol. Chem.* 286 (9), 6929–6939. Available from: <https://doi.org/10.1074/jbc.M110.162289>.
- Fischl, W., Bartenschlager, R., 2011. Exploitation of cellular pathways by dengue virus. *Curr. Opin. Microbiol.* 14 (4), 470–475. Available from: <https://doi.org/10.1016/j.mib.2011.07.012>.
- Flamand, M., Megret, F., Mathieu, M., Lepault, J., Rey, F.A., Deubel, V., 1999. Dengue virus type 1 nonstructural glycoprotein NS1 is secreted from mammalian cells as a soluble hexamer in a glycosylation-dependent fashion. *J. Virol.* 73 (7), 6104–6110.
- Friberg, H., Bashyam, H., Toyosaki-Maeda, T., Potts, J.A., Greenough, T., Kalayanaraj, S., et al., 2011. Cross-reactivity and expansion of dengue-specific T cells during acute primary and secondary infections in humans. *Sci. Rep.* 1, 51. Available from: <https://doi.org/10.1038/srep00051>.
- Friebe, P., Pena, J., Pohl, M.O., Harris, E., 2012. Composition of the sequence downstream of the dengue virus 5' cyclization sequence (dCS) affects viral RNA replication. *Virology* 422 (2), 346–356. Available from: <https://doi.org/10.1016/j.virol.2011.10.025>.
- Fried, J.R., Gibbons, R.V., Kalayanaraj, S., Thomas, S.J., Srikiatkachorn, A., Yoon, I.K., et al., 2010. Serotype-specific differences in the risk of dengue hemorrhagic fever: an

- analysis of data collected in Bangkok, Thailand from 1994 to 2006. *PLoS Negl. Trop. Dis.* 4 (3), e617. Available from: <https://doi.org/10.1371/journal.pntd.0000617>.
- Gamble, J., Bethell, D., Day, N.P., Loc, P.P., Phu, N.H., Gartside, I.B., et al., 2000. Age-related changes in microvascular permeability: a significant factor in the susceptibility of children to shock? *Clin. Sci. (Lond.)* 98 (2), 211–216.
- Garcia, G., del Puerto, F., Perez, A.B., Sierra, B., Aguirre, E., Kikuchi, M., et al., 2011. Association of MICA and MICB alleles with symptomatic dengue infection. *Hum. Immunol.* 72 (10), 904–907. Available from: <https://doi.org/10.1016/j.humimm.2011.06.010>.
- Giatropoulos, A., Papachristos, D.P., Kimbaris, A., Koliopoulos, G., Polissiou, M.G., Emmanouel, N., et al., 2012. Evaluation of bioefficacy of three Citrus essential oils against the dengue vector *Aedes albopictus* (Diptera: Culicidae) in correlation to their components enantiomeric distribution. *Parasitol. Res.* 111 (6), 2253–2263. Available from: <https://doi.org/10.1007/s00436-012-3074-8>.
- Gijavanekar, C., Drabek, R., Soni, M., Jackson, G.W., Strych, U., Fox, G.E., et al., 2012. Detection and typing of viruses using broadly sensitive cocktail-PCR and mass spectrometric cataloging: demonstration with dengue virus. *J. Mol. Diagn.* 14 (4), 402–407. Available from: <https://doi.org/10.1016/j.jmoldx.2012.02.006>.
- Goh, K.C., Tang, C.K., Norton, D.C., Gan, E.S., Tan, H.C., Sun, B., et al., 2016. Molecular determinants of plaque size as an indicator of dengue virus attenuation. *Sci. Rep.* 6, 26100. Available from: <https://doi.org/10.1038/srep26100>.
- Goncalvez, A.P., Engle, R.E., St Claire, M., Purcell, R.H., Lai, C.J., 2007. Monoclonal antibody-mediated enhancement of dengue virus infection in vitro and in vivo and strategies for prevention. *Proc. Natl. Acad. Sci. U.S.A.* 104 (22), 9422–9427. Available from: <https://doi.org/10.1073/pnas.0703498104>.
- Gonzalez, D., Castro, O.E., Kouri, G., Perez, J., Martinez, E., Vazquez, S., et al., 2005. Classical dengue hemorrhagic fever resulting from two dengue infections spaced 20 years or more apart: Havana, Dengue 3 epidemic, 2001–2002. *Int. J. Infect. Dis.* 9 (5), 280–285. Available from: <https://doi.org/10.1016/j.ijid.2004.07.012>.
- Graham, J.D., 1903. A unique pig-sticking accident. *Ind. Med. Gaz.* 38 (10), 376–377.
- Gregory, C.J., Santiago, L.M., Arguello, D.F., Hunsperger, E., Tomashek, K.M., 2010. Clinical and laboratory features that differentiate dengue from other febrile illnesses in an endemic area—Puerto Rico, 2007–2008. *Am. J. Trop. Med. Hyg.* 82 (5), 922–929. Available from: <https://doi.org/10.4269/ajtmh.2010.09-0552>.
- Gubler, D., 2001. Dengue and West Nile virus—an interview with Duane Gubler, Sc.D., reported by Vicki Glaser. *Vector Borne Zoonotic Dis.* 1 (1), 81–88. Available from: <https://doi.org/10.1089/153036601750137741>.
- Gubler, D.J., 1989a. Active surveillance for dengue and dengue hemorrhagic fever. *Bol. Oficina. Sanit. Panam.* 107 (1), 22–30.
- Gubler, D.J., 1989b. Surveillance for dengue and dengue hemorrhagic fever. *Bull. Pan Am. Health Organ.* 23 (4), 397–404.
- Gubler, D.J., 1994. Perspectives on the prevention and control of dengue hemorrhagic fever. *Gaoxiong Yi Xue Ke Xue Za Zhi* 10 (Suppl.), S15–18.
- Gubler, D.J., 1998a. Dengue and dengue hemorrhagic fever. *Clin. Microbiol. Rev.* 11 (3), 480–496.
- Gubler, D.J., 1998b. The global pandemic of dengue/dengue haemorrhagic fever: current status and prospects for the future. *Ann. Acad. Med. Singapore* 27 (2), 227–234.
- Gubler, D.J., 2002. Epidemic dengue/dengue hemorrhagic fever as a public health, social and economic problem in the 21st century. *Trends Microbiol.* 10 (2), 100–103.

- Gubler, D.J., 2011. Dengue, urbanization and globalization: the unholy trinity of the 21(st) century. *Trop. Med. Health* 39 (4 Suppl.), 3–11. Available from: <https://doi.org/10.2149/tmh.2011-S05>.
- Gubler, D.J., 2012. The economic burden of dengue. *Am. J. Trop. Med. Hyg.* 86 (5), 743–744. Available from: <https://doi.org/10.4269/ajtmh.2012.12-0157>.
- Gubler, D.J., 2014. Dengue viruses: their evolution, history and emergence as a global public health problem. In: Ooi, E.E., Gubler, D.J., Vasudevan, S., Farrar, J. (Eds.), *Dengue and Dengue Hemorrhagic Fever*. CAB International.
- Gubler, D.J., Clark, G.G., 1995. Dengue/dengue hemorrhagic fever: the emergence of a global health problem. *Emerg. Infect. Dis.* 1 (2), 55–57. Available from: <https://doi.org/10.3201/eid0102.952004>.
- Gubler, D.J., Rosen, L., 1977. Quantitative aspects of replication of dengue viruses in *Aedes albopictus* (Diptera: Culicidae) after oral and parenteral infection. *J. Med. Entomol.* 13 (4–5), 469–472.
- Gubler, D.J., Reed, D., Rosen, L., Hitchcock Jr., J.R., 1978. Epidemiologic, clinical, and virologic observations on dengue in the Kingdom of Tonga. *Am. J. Trop. Med. Hyg.* 27 (3), 581–589.
- Gubler, D.J., Suharyono, W., Sumarmo, Wulur, H., Jahja, E., Sulianti Saroso, J., 1979. Virological surveillance for dengue haemorrhagic fever in Indonesia using the mosquito inoculation technique. *Bull. World Health Organ.* 57 (6), 931–936.
- Guirakhoo, F., Pugachev, K., Arroyo, J., Miller, C., Zhang, Z.X., Weltzin, R., et al., 2002. Viremia and immunogenicity in nonhuman primates of a tetravalent yellow fever-dengue chimeric vaccine: genetic reconstructions, dose adjustment, and antibody responses against wild-type dengue virus isolates. *Virology* 298 (1), 146–159. Available from: <https://doi.org/10.1006/viro.2002.1462>.
- Gutsche, I., Coulibaly, F., Voss, J.E., Salmon, J., d’Alayer, J., Ermonval, M., et al., 2011. Secreted dengue virus nonstructural protein NS1 is an atypical barrel-shaped high-density lipoprotein. *Proc. Natl. Acad. Sci. U.S.A.* 108 (19), 8003–8008. Available from: <https://doi.org/10.1073/pnas.1017338108>.
- Guzman, M.G., Kouri, G., 2002. Dengue: an update. *Lancet Infect. Dis.* 2 (1), 33–42.
- Guzman, M.G., Kouri, G., 2004. Dengue diagnosis, advances and challenges. *Int. J. Infect. Dis.* 8 (2), 69–80.
- Guzman, M.G., Kouri, G., Bravo, J., Valdes, L., Vazquez, S., Halstead, S.B., 2002. Effect of age on outcome of secondary dengue 2 infections. *Int. J. Infect. Dis.* 6 (2), 118–124.
- Guzman, M.G., Halstead, S.B., Artsob, H., Buchy, P., Farrar, J., Gubler, D.J., et al., 2010. Dengue: a continuing global threat. *Nat. Rev. Microbiol.* 8 (12 Suppl.), S7–16. Available from: <https://doi.org/10.1038/nrmicro2460>.
- Guzman, M.G., Gubler, D.J., Izquierdo, A., Martinez, E., Halstead, S.B., 2016. Dengue infection. *Nat. Rev. Dis. Primers* 2, 16055. Available from: <https://doi.org/10.1038/nrdp.2016.55>.
- Hahn, C.S., Hahn, Y.S., Rice, C.M., Lee, E., Dalgarno, L., Strauss, E.G., et al., 1987. Conserved elements in the 3′ untranslated region of flavivirus RNAs and potential cyclization sequences. *J. Mol. Biol.* 198 (1), 33–41.
- Hall, W.C., Crowell, T.P., Watts, D.M., Barros, V.L., Kruger, H., Pinheiro, F., et al., 1991. Demonstration of yellow fever and dengue antigens in formalin-fixed paraffin-embedded human liver by immunohistochemical analysis. *Am. J. Trop. Med. Hyg.* 45 (4), 408–417.
- Halstead, S.B., 1970. Observations related to pathogenesis of dengue hemorrhagic fever. VI. Hypotheses and discussion. *Yale J. Biol. Med.* 42 (5), 350–362.
- Halstead, S.B., 1988. Pathogenesis of dengue: challenges to molecular biology. *Science* 239 (4839), 476–481.

- Halstead, S.B., 1992. The XXth century dengue pandemic: need for surveillance and research. *World Health Stat. Q.* 45 (2–3), 292–298.
- Halstead, S.B., 2007. Dengue. *Lancet* 370 (9599), 1644–1652. Available from: [https://doi.org/10.1016/S0140-6736\(07\)61687-0](https://doi.org/10.1016/S0140-6736(07)61687-0).
- Halstead, S.B., 2016. Dengue vaccine efficacy: not a zero sum game. *J. Infect. Dis.* 214 (12), 2014. Available from: <https://doi.org/10.1093/infdis/jjw458>.
- Halstead, S.B., Aguiar, M., 2016. Dengue vaccine and the 2016 Olympics. *Lancet* 388 (10041), 237–238. Available from: [https://doi.org/10.1016/S0140-6736\(16\)31048-0](https://doi.org/10.1016/S0140-6736(16)31048-0).
- Halstead, S.B., Deen, J., 2002. The future of dengue vaccines. *Lancet* 360 (9341), 1243–1245. Available from: [https://doi.org/10.1016/S0140-6736\(02\)11276-1](https://doi.org/10.1016/S0140-6736(02)11276-1).
- Halstead, S.B., Lum, L.C., 2009. Assessing the prognosis of dengue-infected patients. *F1000 Med. Rep.* 1. Available from: <https://doi.org/10.3410/M1-73>.
- Halstead, S.B., O'Rourke, E.J., 1977a. Antibody-enhanced dengue virus infection in primate leukocytes. *Nature* 265 (5596), 739–741.
- Halstead, S.B., O'Rourke, E.J., 1977b. Dengue viruses and mononuclear phagocytes. I. Infection enhancement by non-neutralizing antibody. *J. Exp. Med.* 146 (1), 201–217.
- Halstead, S.B., Palumbo, N.E., 1973. Studies on the immunization of monkeys against dengue. II. Protection following inoculation of combinations of viruses. *Am. J. Trop. Med. Hyg.* 22 (3), 375–381.
- Halstead, S.B., Papaevangelou, G., 1980. Transmission of dengue 1 and 2 viruses in Greece in 1928. *Am. J. Trop. Med. Hyg.* 29 (4), 635–637.
- Halstead, S.B., Simasthien, P., 1970. Observations related to the pathogenesis of dengue hemorrhagic fever. II. Antigenic and biologic properties of dengue viruses and their association with disease response in the host. *Yale J. Biol. Med.* 42 (5), 276–292.
- Halstead, S.B., Chow, J.S., Marchette, N.J., 1973a. Immunological enhancement of dengue virus replication. *Nat. New Biol.* 243 (122), 24–26.
- Halstead, S.B., Casals, J., Shotwell, H., Palumbo, N., 1973b. Studies on the immunization of monkeys against dengue. I. Protection derived from single and sequential virus infections. *Am. J. Trop. Med. Hyg.* 22 (3), 365–374.
- Halstead, S.B., Shotwell, H., Casals, J., 1973c. Studies on the pathogenesis of dengue infection in monkeys. I. Clinical laboratory responses to primary infection. *J. Infect. Dis.* 128 (1), 7–14.
- Halstead, S.B., Shotwell, H., Casals, J., 1973d. Studies on the pathogenesis of dengue infection in monkeys. II. Clinical laboratory responses to heterologous infection. *J. Infect. Dis.* 128 (1), 15–22.
- Hammon, W.M., Rudnick, A., Sather, G., Rogers, K.D., Morse, L.J., 1960a. New hemorrhagic fevers of children in the Philippines and Thailand. *Trans. Assoc. Am. Phys.* 73, 140–155.
- Hammon, W.M., Rudnick, A., Sather, G.E., 1960b. Viruses associated with epidemic hemorrhagic fevers of the Philippines and Thailand. *Science* 131 (3407), 1102–1103.
- Hayes, J.M., Rigau-Perez, J.G., Reiter, P., Effler, P.V., Pang, L., Vorndam, V., et al., 2006. Risk factors for infection during a dengue-1 outbreak in Maui, Hawaii, 2001. *Trans. R. Soc. Trop. Med. Hyg.* 100 (6), 559–566. Available from: <https://doi.org/10.1016/j.trstmh.2005.08.013>.
- Heintze, C., Velasco Garrido, M., Kroeger, A., 2007. What do community-based dengue control programmes achieve? A systematic review of published evaluations. *Trans. R. Soc. Trop. Med. Hyg.* 101 (4), 317–325. Available from: <https://doi.org/10.1016/j.trstmh.2006.08.007>.
- Heinz, F.X., Stiasny, K., 2012. Flaviviruses and flavivirus vaccines. *Vaccine* 30 (29), 4301–4306. Available from: <https://doi.org/10.1016/j.vaccine.2011.09.114>.
- Holden, K.L., Stein, D.A., Pierson, T.C., Ahmed, A.A., Clyde, K., Iversen, P.L., et al., 2006. Inhibition of dengue virus translation and RNA synthesis by a morpholino oligomer

- targeted to the top of the terminal 3' stem-loop structure. *Virology* 344 (2), 439–452. Available from: <https://doi.org/10.1016/j.virol.2005.08.034>.
- Holman, D.H., Wang, D., Raviprakash, K., Raja, N.U., Luo, M., Zhang, J., et al., 2007. Two complex, adenovirus-based vaccines that together induce immune responses to all four dengue virus serotypes. *Clin. Vaccine Immunol.* 14 (2), 182–189. Available from: <https://doi.org/10.1128/CVI.00330-06>.
- Hotta, S., 1952. Experimental studies on dengue. I. Isolation, identification and modification of the virus. *J. Infect. Dis.* 90 (1), 1–9.
- Hotta, S., 1953. Dengue epidemics in Japan, 1942–1945. *J. Trop. Med. Hyg.* 56 (4), 83.
- Huang, C.Y., Butrapet, S., Tsuchiya, K.R., Bhamarapavati, N., Gubler, D.J., Kinney, R.M., 2003. Dengue 2 PDK-53 virus as a chimeric carrier for tetravalent dengue vaccine development. *J. Virol.* 77 (21), 11436–11447.
- Hunsperger, E.A., Yoksan, S., Buchy, P., Nguyen, V.C., Sekaran, S.D., Enria, D.A., et al., 2009. Evaluation of commercially available anti-dengue virus immunoglobulin M tests. *Emerg. Infect. Dis.* 15 (3), 436–440. Available from: <https://doi.org/10.3201/eid1503.080923>.
- Iglesias, N.G., Filomatori, C.V., Gamarnik, A.V., 2011. The F1 motif of dengue virus polymerase NS5 is involved in promoter-dependent RNA synthesis. *J. Virol.* 85 (12), 5745–5756. Available from: <https://doi.org/10.1128/JVI.02343-10>.
- Iglesias, N.G., Byk, L.A., Gamarnik, A.V., 2013. Molecular virology of dengue virus. In: Ooi, A.P.E.E., Gubler, D.J., Vasudevan, S., Farrar, J. (Eds.), *Dengue and Dengue Hemorrhagic Fever*. CAB International, pp. 334–365.
- Innis, B.L., Thirawuth, V., Hemachudha, C., 1989. Identification of continuous epitopes of the envelope glycoprotein of dengue type 2 virus. *Am. J. Trop. Med. Hyg.* 40 (6), 676–687.
- Issur, M., Geiss, B.J., Bougie, I., Picard-Jean, F., Despains, S., Mayette, J., et al., 2009. The flavivirus NS5 protein is a true RNA guanylyltransferase that catalyzes a two-step reaction to form the RNA cap structure. *RNA* 15 (12), 2340–2350. Available from: <https://doi.org/10.1261/rna.1609709>.
- Jarman, R.G., Nisalak, A., Anderson, K.B., Klungthong, C., Thaisomboonsuk, B., Kanechit, W., et al., 2011. Factors influencing dengue virus isolation by C6/36 cell culture and mosquito inoculation of nested PCR-positive clinical samples. *Am. J. Trop. Med. Hyg.* 84 (2), 218–223. Available from: <https://doi.org/10.4269/ajtmh.2011.09-0798>.
- Jindadamrongwech, S., Thepparit, C., Smith, D.R., 2004. Identification of GRP 78 (BiP) as a liver cell expressed receptor element for dengue virus serotype 2. *Arch. Virol.* 149 (5), 915–927. Available from: <https://doi.org/10.1007/s00705-003-0263-x>.
- Jittmittraphap, A., Thammapalo, S., Ratanasetyuth, N., Wongba, N., Mammen, M.P., Jampangern, W., 2006. Rapid detection of dengue viral RNA in mosquitoes by nucleic acid-sequence based amplification (NASBA). *Southeast Asian J. Trop. Med. Public Health* 37 (6), 1117–1124.
- Kalayanarooj, S., 2008. Choice of colloidal solutions in dengue hemorrhagic fever patients. *J. Med. Assoc. Thai.* 91 (Suppl. 3), S97–103.
- Kalayanarooj, S., 2011a. Clinical manifestations and management of dengue/DHF/DSS. *Trop. Med. Health* 39 (4 Suppl.), 83–87. Available from: <https://doi.org/10.2149/tmh.2011-S10>.
- Kalayanarooj, S., 2011b. Dengue classification: current WHO vs. the newly suggested classification for better clinical application? *J. Med. Assoc. Thai.* 94 (Suppl. 3), S74–84.
- Kalayanarooj, S., Nimmannitya, S., 2003. Clinical presentations of dengue hemorrhagic fever in infants compared to children. *J. Med. Assoc. Thai.* 86 (Suppl. 3), S673–680.



- Kalayanarooj, S., Vaughn, D.W., Nimmannitya, S., Green, S., Suntayakorn, S., Kunentrasai, N., et al., 1997. Early clinical and laboratory indicators of acute dengue illness. *J. Infect. Dis.* 176 (2), 313–321.
- Kanasa-Thanan, N., Edelman, R., Tacket, C.O., Wasserman, S.S., Vaughn, D.W., Coster, T. S., et al., 2003. Phase 1 studies of Walter Reed Army Institute of Research candidate attenuated dengue vaccines: selection of safe and immunogenic monovalent vaccines. *Am. J. Trop. Med. Hyg.* 69 (6 Suppl.), 17–23.
- Kao, C.L., Wu, M.C., Chiu, Y.H., Lin, J.L., Wu, Y.C., Yueh, Y.Y., et al., 2001. Flow cytometry compared with indirect immunofluorescence for rapid detection of dengue virus type 1 after amplification in tissue culture. *J. Clin. Microbiol.* 39 (10), 3672–3677. Available from: <https://doi.org/10.1128/JCM.39.10.3672-3677.2001>.
- Kapoor, M., Zhang, L., Mohan, P.M., Padmanabhan, R., 1995. Synthesis and characterization of an infectious dengue virus type-2 RNA genome (New Guinea C strain). *Gene* 162 (2), 175–180.
- Kaushik, J.S., Gupta, P., Rajpal, S., Bhatt, S., 2010. Spontaneous resolution of sinoatrial exit block and atrioventricular dissociation in a child with dengue fever. *Singapore Med. J.* 51 (9), e146–148.
- Kawai, T., Akira, S., 2007. Antiviral signaling through pattern recognition receptors. *J. Biochem.* 141 (2), 137–145. Available from: <https://doi.org/10.1093/jb/mvm032>.
- Kay, B.H., Barker-Hudson, P., Stallman, N.D., Wiemers, M.A., Marks, E.N., Holt, P.J., et al., 1984. Dengue fever. Reappearance in northern Queensland after 26 years. *Med. J. Aust.* 140 (5), 264–268.
- Kelley, J.F., Kaufusi, P.H., Nerurkar, V.R., 2012. Dengue hemorrhagic fever-associated immunomodulators induced via maturation of dengue virus nonstructural 4B protein in monocytes modulate endothelial cell adhesion molecules and human microvascular endothelial cells permeability. *Virology* 422 (2), 326–337. Available from: <https://doi.org/10.1016/j.virol.2011.10.030>.
- Khalil, S.M., Tonkin, D.R., Mattocks, M.D., Snead, A.T., Johnston, R.E., White, L.J., 2014. A tetravalent alphavirus-vector based dengue vaccine provides effective immunity in an early life mouse model. *Vaccine* 32 (32), 4068–4074. Available from: <https://doi.org/10.1016/j.vaccine.2014.05.053>.
- Khan, E., Kisat, M., Khan, N., Nasir, A., Ayub, S., Hasan, R., 2010. Demographic and clinical features of dengue fever in Pakistan from 2003–2007: a retrospective cross-sectional study. *PLoS One* 5 (9), e12505. Available from: <https://doi.org/10.1371/journal.pone.0012505>.
- Khor, C.C., Chau, T.N., Pang, J., Davila, S., Long, H.T., Ong, R.T., et al., 2011. Genome-wide association study identifies susceptibility loci for dengue shock syndrome at MICB and PLCE1. *Nat. Genet.* 43 (11), 1139–1141. Available from: <https://doi.org/10.1038/ng.960>.
- Kinney, R.M., Butrapet, S., Chang, G.J., Tsuchiya, K.R., Roehrig, J.T., Bhamarapravati, N., et al., 1997. Construction of infectious cDNA clones for dengue 2 virus: strain 16681 and its attenuated vaccine derivative, strain PDK-53. *Virology* 230 (2), 300–308. Available from: <https://doi.org/10.1006/viro.1997.8500>.
- Klungthong, C., Gibbons, R.V., Thaisomboonsuk, B., Nisalak, A., Kalayanarooj, S., Thirawuth, V., et al., 2007. Dengue virus detection using whole blood for reverse transcriptase PCR and virus isolation. *J. Clin. Microbiol.* 45 (8), 2480–2485. Available from: <https://doi.org/10.1128/JCM.00305-07>.
- Kochel, T., Wu, S.J., Raviprakash, K., Hobart, P., Hoffman, S., Porter, K., et al., 1997. Inoculation of plasmids expressing the dengue-2 envelope gene elicit neutralizing antibodies in mice. *Vaccine* 15 (5), 547–552.
- Kochel, T.J., Watts, D.M., Halstead, S.B., Hayes, C.G., Espinoza, A., Felices, V., et al., 2002. Effect of dengue-1 antibodies on American dengue-2 viral infection and dengue



- haemorrhagic fever. *Lancet* 360 (9329), 310–312. Available from: [https://doi.org/10.1016/S0140-6736\(02\)09522-3](https://doi.org/10.1016/S0140-6736(02)09522-3).
- Kovendan, K., Arivoli, S., Maheshwaran, R., Baskar, K., Vincent, S., 2012. Larvicidal efficacy of *Sphaeranthus indicus*, *Cleistanthus collinus* and *Murraya koenigii* leaf extracts against filarial vector, *Culex quinquefasciatus* Say (Diptera: Culicidae). *Parasitol. Res.* 111 (3), 1025–1035. Available from: <https://doi.org/10.1007/s00436-012-2927-5>.
- Kovendan, K., Murugan, K., Mahesh Kumar, P., Thiyagarajan, P., John William, S., 2013. Ovicidal, repellent, adulticidal and field evaluations of plant extract against dengue, malaria and filarial vectors. *Parasitol. Res.* 112 (3), 1205–1219. Available from: <https://doi.org/10.1007/s00436-012-3252-8>.
- Krishnan, M.N., Sukumaran, B., Pal, U., Agaisse, H., Murray, J.L., Hodge, T.W., et al., 2007. Rab 5 is required for the cellular entry of dengue and West Nile viruses. *J. Virol.* 81 (9), 4881–4885. Available from: <https://doi.org/10.1128/JVI.02210-06>.
- Kuberski, T., Rosen, L., Reed, D., Mataika, J., 1977. Clinical and laboratory observations on patients with primary and secondary dengue type 1 infections with hemorrhagic manifestations in Fiji. *Am. J. Trop. Med. Hyg.* 26 (4), 775–783.
- Kuhn, R.J., Zhang, W., Rossmann, M.G., Pletnev, S.V., Corver, J., Lenches, E., et al., 2002. Structure of dengue virus: implications for flavivirus organization, maturation, and fusion. *Cell* 108 (5), 717–725.
- Kuno, G., 2007. Research on dengue and dengue-like illness in East Asia and the Western Pacific during the First Half of the 20th century. *Rev. Med. Virol.* 17 (5), 327–341. Available from: <https://doi.org/10.1002/rmv.545>.
- Kuno, G., 2009. Emergence of the severe syndrome and mortality associated with dengue and dengue-like illness: historical records (1890 to 1950) and their compatibility with current hypotheses on the shift of disease manifestation. *Clin. Microbiol. Rev.* 22 (2), 186–201. Available from: <https://doi.org/10.1128/CMR.00052-08>. Table of Contents.
- Kuno, G., 2012. Revisiting Houston and Memphis: the background histories behind the discovery of the infestation by *Aedes albopictus* (Diptera: Culicidae) in the United States and their significance in the contemporary research. *J. Med. Entomol.* 49 (6), 1163–1176.
- Kuno, G., Cropp, C.B., Wong-Lee, J., Gubler, D.J., 1998. Evaluation of an IgM immunoblot kit for dengue diagnosis. *Am. J. Trop. Med. Hyg.* 59 (5), 757–762.
- Kurane, I., 2007. Dengue hemorrhagic fever with special emphasis on immunopathogenesis. *Comp. Immunol. Microbiol. Infect. Dis.* 30 (5–6), 329–340. Available from: <https://doi.org/10.1016/j.cimid.2007.05.010>.
- Kurane, I., Innis, B.L., Nisalak, A., Hoke, C., Nimmannitya, S., Meager, A., et al., 1989. Human T cell responses to dengue virus antigens. Proliferative responses and interferon gamma production. *J. Clin. Invest.* 83 (2), 506–513. Available from: <https://doi.org/10.1172/JCI113911>.
- Kurane, I., Zeng, L., Brinton, M.A., Ennis, F.A., 1998. Definition of an epitope on NS3 recognized by human CD4+ cytotoxic T lymphocyte clones cross-reactive for dengue virus types 2, 3, and 4. *Virology* 240 (2), 169–174. Available from: <https://doi.org/10.1006/viro.1997.8925>.
- Lai, C.J., Zhao, B.T., Hori, H., Bray, M., 1991. Infectious RNA transcribed from stably cloned full-length cDNA of dengue type 4 virus. *Proc. Natl. Acad. Sci. U.S.A.* 88 (12), 5139–5143.
- Lanciotti, R.S., Calisher, C.H., Gubler, D.J., Chang, G.J., Vorndam, A.V., 1992. Rapid detection and typing of dengue viruses from clinical samples by using reverse transcriptase-polymerase chain reaction. *J. Clin. Microbiol.* 30 (3), 545–551.
- Laoprasopwattana, K., Pruekprasert, P., Dissaneewate, P., Geater, A., Vachvanichsanong, P., 2010. Outcome of dengue hemorrhagic fever-caused acute kidney injury in Thai

- children. *J. Pediatr.* 157 (2), 303–309. Available from: <https://doi.org/10.1016/j.jpeds.2010.02.008>.
- Lau, Y.L., Lai, M.Y., Teoh, B.T., Abd-Jamil, J., Johari, J., Sam, S.S., et al., 2015. Colorimetric detection of dengue by single tube reverse-transcription-loop-mediated isothermal amplification. *PLoS One* 10 (9), e0138694. Available from: <https://doi.org/10.1371/journal.pone.0138694>.
- Leo, Y.S., Thein, T.L., Fisher, D.A., Low, J.G., Oh, H.M., Narayanan, R.L., et al., 2011. Confirmed adult dengue deaths in Singapore: 5-year multi-center retrospective study. *BMC Infect. Dis.* 11, 123. Available from: <https://doi.org/10.1186/1471-2334-11-123>.
- Leyssen, P., Van Lommel, A., Drosten, C., Schmitz, H., De Clercq, E., Neyts, J., 2001. A novel model for the study of the therapy of flavivirus infections using the Modoc virus. *Virology* 279 (1), 27–37. Available from: <https://doi.org/10.1006/viro.2000.0723>.
- Li, L., Lok, S.M., Yu, I.M., Zhang, Y., Kuhn, R.J., Chen, J., et al., 2008. The flavivirus precursor membrane-envelope protein complex: structure and maturation. *Science* 319 (5871), 1830–1834. Available from: <https://doi.org/10.1126/science.1153263>.
- Li, Z., Yang, H., Yang, J., Lin, H., Wang, W., Liu, L., et al., 2014. Construction and preliminary investigation of a novel dengue serotype 4 chimeric virus using Japanese encephalitis vaccine strain SA14-14-2 as the backbone. *Virus Res.* 191, 10–20. Available from: <https://doi.org/10.1016/j.virusres.2014.07.017>.
- Libraty, D.H., Young, P.R., Pickering, D., Endy, T.P., Kalayanarooj, S., Green, S., et al., 2002a. High circulating levels of the dengue virus nonstructural protein NS1 early in dengue illness correlate with the development of dengue hemorrhagic fever. *J. Infect. Dis.* 186 (8), 1165–1168. Available from: <https://doi.org/10.1086/343813>.
- Libraty, D.H., Endy, T.P., Houg, H.S., Green, S., Kalayanarooj, S., Suntayakorn, S., et al., 2002b. Differing influences of virus burden and immune activation on disease severity in secondary dengue-3 virus infections. *J. Infect. Dis.* 185 (9), 1213–1221. Available from: <https://doi.org/10.1086/340365>.
- Lin, C.F., Wan, S.W., Cheng, H.J., Lei, H.Y., Lin, Y.S., 2006. Autoimmune pathogenesis in dengue virus infection. *Viral Immunol.* 19 (2), 127–132. Available from: <https://doi.org/10.1089/vim.2006.19.127>.
- Lindenbach, B.D., Rice, C.M., 1997. trans-Complementation of yellow fever virus NS1 reveals a role in early RNA replication. *J. Virol.* 71 (12), 9608–9617.
- Lindenbach, B.D., Pragai, B.M., Montserret, R., Beran, R.K., Pyle, A.M., Penin, F., et al., 2007. The C terminus of hepatitis C virus NS4A encodes an electrostatic switch that regulates NS5A hyperphosphorylation and viral replication. *J. Virol.* 81 (17), 8905–8918. Available from: <https://doi.org/10.1128/JVI.00937-07>.
- Lodeiro, M.F., Filomatori, C.V., Gamarnik, A.V., 2009. Structural and functional studies of the promoter element for dengue virus RNA replication. *J. Virol.* 83 (2), 993–1008. Available from: <https://doi.org/10.1128/JVI.01647-08>.
- Lofgren, C.S., 1972. Ultralow volume (ULV) application of insecticides. *Am. J. Trop. Med. Hyg.* 21 (5), 819–824.
- Loke, H., Bethell, D., Phuong, C.X., Day, N., White, N., Farrar, J., et al., 2002. Susceptibility to dengue hemorrhagic fever in Vietnam: evidence of an association with variation in the vitamin d receptor and Fc gamma receptor IIa genes. *Am. J. Trop. Med. Hyg.* 67 (1), 102–106.
- Lukman, N., Salim, G., Kosasih, H., Susanto, N.H., Parwati, I., Fitri, S., et al., 2016. Comparison of the hemagglutination inhibition test and IgG ELISA in categorizing primary and secondary dengue infections based on the plaque reduction neutralization test. *Biomed. Res. Int.* 2016, 5253842. Available from: <https://doi.org/10.1155/2016/5253842>.
- Lum, L.C., Suaya, J.A., Tan, L.H., Sah, B.K., Shepard, D.S., 2008. Quality of life of dengue patients. *Am. J. Trop. Med. Hyg.* 78 (6), 862–867.

- Luz, P.M., Vanni, T., Medlock, J., Paltiel, A.D., Galvani, A.P., 2011. Dengue vector control strategies in an urban setting: an economic modelling assessment. *Lancet* 377 (9778), 1673–1680. Available from: [https://doi.org/10.1016/S0140-6736\(11\)60246-8](https://doi.org/10.1016/S0140-6736(11)60246-8).
- Mackenzie, J.S., Williams, D.T., 2009. The zoonotic flaviviruses of southern, south-eastern and eastern Asia, and Australasia: the potential for emergent viruses. *Zoonoses Public Health* 56 (6–7), 338–356. Available from: <https://doi.org/10.1111/j.1863-2378.2008.01208.x>.
- Mackenzie, J.M., Jones, M.K., Young, P.R., 1996. Immunolocalization of the dengue virus nonstructural glycoprotein NS1 suggests a role in viral RNA replication. *Virology* 220 (1), 232–240. Available from: <https://doi.org/10.1006/viro.1996.0307>.
- Mady, B.J., Erbe, D.V., Kurane, I., Fanger, M.W., Ennis, F.A., 1991. Antibody-dependent enhancement of dengue virus infection mediated by bispecific antibodies against cell surface molecules other than Fc gamma receptors. *J. Immunol.* 147 (9), 3139–3144.
- Mahesh Kumar, P., Kovendan, K., Murugan, K., 2013. Integration of botanical and bacterial insecticide against *Aedes aegypti* and *Anopheles stephensi*. *Parasitol. Res.* 112 (2), 761–771. Available from: <https://doi.org/10.1007/s00436-012-3196-z>.
- Mahmod, M., Darul, N.D., Mokhtar, I., Nor, N.M., Anshar, F.M., Maskon, O., 2009. Atrial fibrillation as a complication of dengue hemorrhagic fever: non-self-limiting manifestation. *Int. J. Infect. Dis.* 13 (5), e316–318. Available from: <https://doi.org/10.1016/j.ijid.2009.01.017>.
- Malasit, P., 1987. Complement and dengue haemorrhagic fever/shock syndrome. *Southeast Asian J. Trop. Med. Public Health* 18 (3), 316–320.
- Mansfield, K.L., Horton, D.L., Johnson, N., Li, L., Barrett, A.D., Smith, D.J., et al., 2011. Flavivirus-induced antibody cross-reactivity. *J. Gen. Virol.* 92 (Pt 12), 2821–2829. Available from: <https://doi.org/10.1099/vir.0.031641-0>.
- Marchette, N.J., Rudnick, A., Garcia, R., MacVean, D.W., 1978. Alphaviruses in Peninsular Malaysia: I. Virus isolations and animal serology. *Southeast Asian J. Trop. Med. Public Health* 9 (3), 317–329.
- Markoff, L., Falgout, B., Chang, A., 1997. A conserved internal hydrophobic domain mediates the stable membrane integration of the dengue virus capsid protein. *Virology* 233 (1), 105–117. Available from: <https://doi.org/10.1006/viro.1997.8608>.
- Massad, E., Coutinho, F.A., 2011. The cost of dengue control. *Lancet* 377 (9778), 1630–1631. Available from: [https://doi.org/10.1016/S0140-6736\(11\)60470-4](https://doi.org/10.1016/S0140-6736(11)60470-4).
- Mehlhop, E., Fuchs, A., Engle, M., Diamond, M.S., 2009. Complement modulates pathogenesis and antibody-dependent neutralization of West Nile virus infection through a C5-independent mechanism. *Virology* 393 (1), 11–15. Available from: <https://doi.org/10.1016/j.virol.2009.08.019>.
- Men, R., Wyatt, L., Tokimatsu, I., Arakaki, S., Shameem, G., Elkins, R., et al., 2000. Immunization of rhesus monkeys with a recombinant of modified vaccinia virus Ankara expressing a truncated envelope glycoprotein of dengue type 2 virus induced resistance to dengue type 2 virus challenge. *Vaccine* 18 (27), 3113–3122.
- Miagostovich, M.P., dos Santos, F.B., de Araujo, E.S., Dias, J., Schatzmayr, H.G., Nogueira, R.M., 1997. Diagnosis of dengue by using reverse transcriptase-polymerase chain reaction. *Mem. Inst. Oswaldo Cruz* 92 (5), 595–599.
- Miller, S., Sparacio, S., Bartenschlager, R., 2006. Subcellular localization and membrane topology of the dengue virus type 2 non-structural protein 4B. *J. Biol. Chem.* 281 (13), 8854–8863. Available from: <https://doi.org/10.1074/jbc.M512697200>.
- Miller, S., Kastner, S., Krijnse-Locker, J., Buhler, S., Bartenschlager, R., 2007. The non-structural protein 4A of dengue virus is an integral membrane protein inducing membrane alterations in a 2K-regulated manner. *J. Biol. Chem.* 282 (12), 8873–8882. Available from: <https://doi.org/10.1074/jbc.M609919200>.

- Miller, J.L., de Wet, B.J., Martinez-Pomares, L., Radcliffe, C.M., Dwek, R.A., Rudd, P.M., et al., 2008. The mannose receptor mediates dengue virus infection of macrophages. *PLoS Pathog.* 4 (2), e17. Available from: <https://doi.org/10.1371/journal.ppat.0040017>.
- Modis, Y., Ogata, S., Clements, D., Harrison, S.C., 2004. Structure of the dengue virus envelope protein after membrane fusion. *Nature* 427 (6972), 313–319. Available from: <https://doi.org/10.1038/nature02165>.
- Moncayo, A.C., Fernandez, Z., Ortiz, D., Diallo, M., Sall, A., Hartman, S., et al., 2004. Dengue emergence and adaptation to peridomestic mosquitoes. *Emerg. Infect. Dis.* 10 (10), 1790–1796. Available from: <https://doi.org/10.3201/eid1010.030846>.
- Mongkolsapaya, J., Duangchinda, T., Dejnirattisai, W., Vasanawathana, S., Avirutnan, P., Jairungsri, A., et al., 2006. T cell responses in dengue hemorrhagic fever: are cross-reactive T cells suboptimal?. *J. Immunol.* 176 (6), 3821–3829.
- Moreau, J.P., Rosen, L., Saugrain, J., Lagraulet, J., 1973. An epidemic of dengue on Tahiti associated with hemorrhagic manifestations. *Am. J. Trop. Med. Hyg.* 22 (2), 237–241.
- Morrison, J., Aguirre, S., Fernandez-Sesma, A., 2012. Innate immunity evasion by dengue virus. *Viruses* 4 (3), 397–413. Available from: <https://doi.org/10.3390/v4030397>.
- Muller, D.A., Corrie, S.R., Coffey, J., Young, P.R., Kendall, M.A., 2012. Surface modified microprojection arrays for the selective extraction of the dengue virus NS1 protein as a marker for disease. *Anal. Chem.* 84 (7), 3262–3268. Available from: <https://doi.org/10.1021/ac2034387>.
- Murray, N.E., Quam, M.B., Wilder-Smith, A., 2013. Epidemiology of dengue: past, present and future prospects. *Clin. Epidemiol.* 5, 299–309. Available from: <https://doi.org/10.2147/CLEP.S34440>.
- Nasirudeen, A.M., Wong, H.H., Thien, P., Xu, S., Lam, K.P., Liu, D.X., 2011. RIG-I, MDA5 and TLR3 synergistically play an important role in restriction of dengue virus infection. *PLoS Negl. Trop. Dis.* 5 (1), e926. Available from: <https://doi.org/10.1371/journal.pntd.0000926>.
- Nayak, V., Dessau, M., Kucera, K., Anthony, K., Ledizet, M., Modis, Y., 2009. Crystal structure of dengue virus type 1 envelope protein in the postfusion conformation and its implications for membrane fusion. *J. Virol.* 83 (9), 4338–4344. Available from: <https://doi.org/10.1128/JVI.02574-08>.
- Netsawang, J., Noisakran, S., Puttikhunt, C., Kasinrerak, W., Wongwiwat, W., Malasit, P., et al., 2010. Nuclear localization of dengue virus capsid protein is required for DAXX interaction and apoptosis. *Virus Res.* 147 (2), 275–283. Available from: <https://doi.org/10.1016/j.virusres.2009.11.012>.
- Nguyen, T.P., Kikuchi, M., Vu, T.Q., Do, Q.H., Tran, T.T., Vo, D.T., et al., 2008. Protective and enhancing HLA alleles, HLA-DRB1\*0901 and HLA-A\*24, for severe forms of dengue virus infection, dengue hemorrhagic fever and dengue shock syndrome. *PLoS Negl. Trop. Dis.* 2 (10), e304. Available from: <https://doi.org/10.1371/journal.pntd.0000304>.
- Nguyen, N.M., Tran, C.N., Phung, L.K., Duong, K.T., Huynh Hle, A., Farrar, J., et al., 2013. A randomized, double-blind placebo controlled trial of balapiravir, a polymerase inhibitor, in adult dengue patients. *J. Infect. Dis.* 207 (9), 1442–1450. Available from: <https://doi.org/10.1093/infdis/jis470>.
- Nisalak, A., Endy, T.P., Nimmannitya, S., Kalayanarooj, S., Thisyakorn, U., Scott, R.M., et al., 2003. Serotype-specific dengue virus circulation and dengue disease in Bangkok, Thailand from 1973 to 1999. *Am. J. Trop. Med. Hyg.* 68 (2), 191–202.
- Noble, C.G., Chen, Y.L., Dong, H., Gu, F., Lim, S.P., Schul, W., et al., 2010. Strategies for development of dengue virus inhibitors. *Antiviral Res.* 85 (3), 450–462. Available from: <https://doi.org/10.1016/j.antiviral.2009.12.011>.

- Normile, D., 2013. Tropical medicine. Surprising new dengue virus throws a spanner in disease control efforts. *Science* 342 (6157), 415. Available from: <https://doi.org/10.1126/science.342.6157.415>.
- OhAinle, M., Balmaseda, A., Macalalad, A.R., Tellez, Y., Zody, M.C., Saborio, S., et al., 2011. Dynamics of dengue disease severity determined by the interplay between viral genetics and serotype-specific immunity. *Sci. Transl. Med.* 3 (114), 114ra128. Available from: <https://doi.org/10.1126/scitranslmed.3003084>.
- Osorio, J.E., Brewoo, J.N., Silengo, S.J., Arguello, J., Moldovan, I.R., Tary-Lehmann, M., et al., 2011a. Efficacy of a tetravalent chimeric dengue vaccine (DENVax) in *Cynomolgus* macaques. *Am. J. Trop. Med. Hyg.* 84 (6), 978–987. Available from: <https://doi.org/10.4269/ajtmh.2011.10-0592>.
- Osorio, J.E., Huang, C.Y., Kinney, R.M., Stinchcomb, D.T., 2011b. Development of DENVax: a chimeric dengue-2 PDK-53-based tetravalent vaccine for protection against dengue fever. *Vaccine* 29 (42), 7251–7260. Available from: <https://doi.org/10.1016/j.vaccine.2011.07.020>.
- Pang, J., Salim, A., Lee, V.J., Hibberd, M.L., Chia, K.S., Leo, Y.S., et al., 2012. Diabetes with hypertension as risk factors for adult dengue hemorrhagic fever in a predominantly dengue serotype 2 epidemic: a case control study. *PLoS Negl. Trop. Dis.* 6 (5), e1641. Available from: <https://doi.org/10.1371/journal.pntd.0001641>.
- Patkar, C.G., Kuhn, R.J., 2008. Yellow fever virus NS3 plays an essential role in virus assembly independent of its known enzymatic functions. *J. Virol.* 82 (7), 3342–3352. Available from: <https://doi.org/10.1128/JVI.02447-07>.
- Peeling, R.W., Artsob, H., Pelegrino, J.L., Buchy, P., Cardoso, M.J., Devi, S., et al., 2010. Evaluation of diagnostic tests: dengue. *Nat. Rev. Microbiol.* 8 (12 Suppl.), S30–38. Available from: <https://doi.org/10.1038/nrmicro2459>.
- Pelliccia, S., Wu, Y.H., Coluccia, A., La Regina, G., Tseng, C.K., Famiglini, V., et al., 2017. Inhibition of dengue virus replication by novel inhibitors of RNA-dependent RNA polymerase and protease activities. *J. Enzyme Inhib. Med. Chem.* 32 (1), 1091–1101. Available from: <https://doi.org/10.1080/14756366.2017.1355791>.
- Perez, A.B., Sierra, B., Garcia, G., Aguirre, E., Babel, N., Alvarez, M., et al., 2010. Tumor necrosis factor- $\alpha$ , transforming growth factor- $\beta$ 1, and interleukin-10 gene polymorphisms: implication in protection or susceptibility to dengue hemorrhagic fever. *Hum. Immunol.* 71 (11), 1135–1140. Available from: <https://doi.org/10.1016/j.humimm.2010.08.004>.
- Polacek, C., Friebe, P., Harris, E., 2009. Poly(A)-binding protein binds to the non-polyadenylated 3' untranslated region of dengue virus and modulates translation efficiency. *J. Gen. Virol.* 90 (Pt 3), 687–692. Available from: <https://doi.org/10.1099/vir.0.007021-0>.
- Prado, I., Rosario, D., Bernardo, L., Alvarez, M., Rodriguez, R., Vazquez, S., et al., 2005. PCR detection of dengue virus using dried whole blood spotted on filter paper. *J. Virol. Methods* 125 (1), 75–81. Available from: <https://doi.org/10.1016/j.jviromet.2005.01.001>.
- Proutski, V., Gould, E.A., Holmes, E.C., 1997. Secondary structure of the 3' untranslated region of flaviviruses: similarities and differences. *Nucleic Acids Res.* 25 (6), 1194–1202.
- Qiu, F.X., Gubler, D.J., Liu, J.C., Chen, Q.Q., 1993. Dengue in China: a clinical review. *Bull. World Health Organ.* 71 (3–4), 349–359.
- Rabablt, J., Yoksan, S., 2009. Attenuated D2 16681-PDK53 vaccine: defining humoral and cell-mediated immunity. *Curr. Pharm. Des.* 15 (11), 1203–1211.
- Rauscher, S., Flamm, C., Mandl, C.W., Heinz, F.X., Stadler, P.F., 1997. Secondary structure of the 3'-noncoding region of flavivirus genomes: comparative analysis of base pairing probabilities. *RNA* 3 (7), 779–791.

- Raviprakash, K., Wang, D., Ewing, D., Holman, D.H., Block, K., Woraratanadharm, J., et al., 2008. A tetravalent dengue vaccine based on a complex adenovirus vector provides significant protection in rhesus monkeys against all four serotypes of dengue virus. *J. Virol.* 82 (14), 6927–6934. Available from: <https://doi.org/10.1128/JVI.02724-07>.
- Reed, W., Carroll, J., Agramonte, A., Lazear, J.W., 1900. The etiology of yellow fever—a preliminary note. *Public Health Pap. Rep.* 26, 37–53.
- Reiser, M., Hinrichsen, H., Benhamou, Y., Reesink, H.W., Wedemeyer, H., Avendano, C., et al., 2005. Antiviral efficacy of NS3-serine protease inhibitor BILN-2061 in patients with chronic genotype 2 and 3 hepatitis C. *Hepatology* 41 (4), 832–835. Available from: <https://doi.org/10.1002/hep.20612>.
- Rey, F.A., Heinz, F.X., Mandl, C., Kunz, C., Harrison, S.C., 1995. The envelope glycoprotein from tick-borne encephalitis virus at 2 Å resolution. *Nature* 375 (6529), 291–298. Available from: <https://doi.org/10.1038/375291a0>.
- Rico-Hesse, R., 2010. Dengue virus virulence and transmission determinants. *Curr. Top. Microbiol. Immunol.* 338, 45–55. Available from: [https://doi.org/10.1007/978-3-642-02215-9\\_4](https://doi.org/10.1007/978-3-642-02215-9_4).
- Rigau-Pérez, J.G., Clark, G.G., Gubler, D.J., Reiter, P., Sanders, E.J., Vance Vorndam, A., 1998. Dengue and dengue haemorrhagic fever. *Lancet* 352 (9132), 971–977. Available from: [https://doi.org/10.1016/s0140-6736\(97\)12483-7](https://doi.org/10.1016/s0140-6736(97)12483-7).
- Robert, V., Lhuillier, M., Meunier, D., Sarthou, J.L., Monteny, N., Digoutte, J.P., et al., 1993. Yellow fever virus, dengue 2 and other arboviruses isolated from mosquitos, in Burkina Faso, from 1983 to 1986. Entomological and epidemiological considerations. *Bull. Soc. Pathol. Exot.* 86 (2), 90–100.
- Rodenhuis-Zybert, I.A., Wilschut, J., Smit, J.M., 2010. Dengue virus life cycle: viral and host factors modulating infectivity. *Cell. Mol. Life Sci.* 67 (16), 2773–2786. Available from: <https://doi.org/10.1007/s00018-010-0357-z>.
- Rosen, L., 1977. The Emperor's New Clothes revisited, or reflections on the pathogenesis of dengue hemorrhagic fever. *Am. J. Trop. Med. Hyg.* 26 (3), 337–343.
- Rosen, L., 1986. Dengue in Greece in 1927 and 1928 and the pathogenesis of dengue hemorrhagic fever: new data and a different conclusion. *Am. J. Trop. Med. Hyg.* 35 (3), 642–653.
- Sabin, A.B., 1952. Research on dengue during World War II. *Am. J. Trop. Med. Hyg.* 1 (1), 30–50.
- Sabin, A.B., Schlesinger, R.W., 1945. Production of immunity to dengue with virus modified by propagation in mice. *Science* 101 (2634), 640–642. Available from: <https://doi.org/10.1126/science.101.2634.640>.
- Sahni, A.K., Grover, N., Sharma, A., Khan, I.D., Kishore, J., 2013. Reverse transcription loop-mediated isothermal amplification (RT-LAMP) for diagnosis of dengue. *Med. J. Armed Forces India* 69 (3), 246–253. Available from: <https://doi.org/10.1016/j.mjafi.2012.07.017>.
- Sakuntabhai, A., Turbpaiboon, C., Casademont, I., Chuansumrit, A., Lowhnoo, T., Kajaste-Rudnitski, A., et al., 2005. A variant in the CD209 promoter is associated with severity of dengue disease. *Nat. Genet.* 37 (5), 507–513. Available from: <https://doi.org/10.1038/ng1550>.
- Samsa, M.M., Mondotte, J.A., Caramelo, J.J., Gamarnik, A.V., 2012. Uncoupling cis-Acting RNA elements from coding sequences revealed a requirement of the N-terminal region of dengue virus capsid protein in virus particle formation. *J. Virol.* 86 (2), 1046–1058. Available from: <https://doi.org/10.1128/JVI.05431-11>.
- Sangiambut, S., Keelapang, P., Aaskov, J., Puttikhunt, C., Kasinrerak, W., Malasit, P., et al., 2008. Multiple regions in dengue virus capsid protein contribute to nuclear localization



- during virus infection. *J. Gen. Virol.* 89 (Pt 5), 1254–1264. Available from: <https://doi.org/10.1099/vir.0.83264-0>.
- Schmidt, A.G., Yang, P.L., Harrison, S.C., 2010. Peptide inhibitors of dengue-virus entry target a late-stage fusion intermediate. *PLoS Pathog.* 6 (4), e1000851. Available from: <https://doi.org/10.1371/journal.ppat.1000851>.
- Schmidt, A.G., Lee, K., Yang, P.L., Harrison, S.C., 2012. Small-molecule inhibitors of dengue-virus entry. *PLoS Pathog.* 8 (4), e1002627. Available from: <https://doi.org/10.1371/journal.ppat.1002627>.
- Schoggins, J.W., Dorner, M., Feulner, M., Imanaka, N., Murphy, M.Y., Ploss, A., et al., 2012. Dengue reporter viruses reveal viral dynamics in interferon receptor-deficient mice and sensitivity to interferon effectors in vitro. *Proc. Natl. Acad. Sci. U.S.A.* 109 (6), 14610–14615. Available from: <https://doi.org/10.1073/pnas.1212379109>.
- Schuller, A., Yin, Z., Brian Chia, C.S., Doan, D.N., Kim, H.K., Shang, L., et al., 2011. Tripeptide inhibitors of dengue and West Nile virus NS2B-NS3 protease. *Antiviral Res.* 92 (1), 96–101. Available from: <https://doi.org/10.1016/j.antiviral.2011.07.002>.
- Seet, R.C., Quek, A.M., Lim, E.C., 2007a. Post-infectious fatigue syndrome in dengue infection. *J. Clin. Virol.* 38 (1), 1–6. Available from: <https://doi.org/10.1016/j.jcv.2006.10.011>.
- Seet, R.C., Quek, A.M., Lim, E.C., 2007b. Symptoms and risk factors of ocular complications following dengue infection. *J. Clin. Virol.* 38 (2), 101–105. Available from: <https://doi.org/10.1016/j.jcv.2006.11.002>.
- Shepard, D.S., Suaya, J.A., Halstead, S.B., Nathan, M.B., Gubler, D.J., Mahoney, R.T., et al., 2004. Cost-effectiveness of a pediatric dengue vaccine. *Vaccine* 22 (9–10), 1275–1280. Available from: <https://doi.org/10.1016/j.vaccine.2003.09.019>.
- Shepard, D.S., Undurraga, E.A., Lees, R.S., Halasa, Y., Lum, L.C., Ng, C.W., 2012. Use of multiple data sources to estimate the economic cost of dengue illness in Malaysia. *Am. J. Trop. Med. Hyg.* 87 (5), 796–805. Available from: <https://doi.org/10.4269/ajtmh.2012.12-0019>.
- Shepard, D.S., Halasa, Y.A., Undurraga, E.A., 2014. Economic and disease burden of dengue. In: Ooi, E.E., Gubler, D.J., Vasudevan, S., Farrar, J. (Eds.), *Dengue and Dengue Hemorrhagic Fever*. CAB International.
- Shurtleff, A.C., Beasley, D.W., Chen, J.J., Ni, H., Suderman, M.T., Wang, H., et al., 2001. Genetic variation in the 3' non-coding region of dengue viruses. *Virology* 281 (1), 75–87. Available from: <https://doi.org/10.1006/viro.2000.0748>.
- Silva, R.L., de Silva, A.M., Harris, E., MacDonald, G.H., 2008. Genetic analysis of dengue 3 virus subtype III 5' and 3' non-coding regions. *Virus Res.* 135 (2), 320–325. Available from: <https://doi.org/10.1016/j.virusres.2008.03.007>.
- Simmons, A.H., 1931. Tularemia. *J. Natl. Med. Assoc.* 23 (1), 10–18.
- Simmons, M., Nelson, W.M., Wu, S.J., Hayes, C.G., 1998. Evaluation of the protective efficacy of a recombinant dengue envelope B domain fusion protein against dengue 2 virus infection in mice. *Am. J. Trop. Med. Hyg.* 58 (5), 655–662.
- Simmons, C.P., Farrar, J.J., Nguyen, V.V., Wills, B., 2012. Dengue. *N. Engl. J. Med.* 366 (15), 1423–1432. Available from: <https://doi.org/10.1056/NEJMra1110265>.
- Sinkins, S.P., Gould, F., 2006. Gene drive systems for insect disease vectors. *Nat. Rev. Genet.* 7 (6), 427–435. Available from: <https://doi.org/10.1038/nrg1870>.
- Siqueira, J.B., Martelli, C.M., Maciel, I.J., Oliveira, R.M., Ribeiro, M.G., Amorim, F.P., et al., 2004a. Household survey of dengue infection in central Brazil: spatial point pattern analysis and risk factors assessment. *Am. J. Trop. Med. Hyg.* 71 (5), 646–651.
- Siqueira, R.C., Vitral, N.P., Campos, W.R., Orefice, F., de Moraes Figueiredo, L.T., 2004b. Ocular manifestations in dengue fever. *Ocul. Immunol. Inflamm.* 12 (4), 323–327. Available from: <https://doi.org/10.1080/092739490500345>.
- Sirivichayakul, C., Limkittikul, K., Chanthavanich, P., Jiwariyavej, V., Chokeyindachai, W., Pengsaa, K., et al., 2012. Dengue infection in children in Ratchaburi, Thailand: a cohort



- study. II. Clinical manifestations. *PLoS Negl. Trop. Dis.* 6 (2), e1520. Available from: <https://doi.org/10.1371/journal.pntd.0001520>.
- Smith, C.E., 1956a. The history of dengue in tropical Asia and its probable relationship to the mosquito *Aedes aegypti*. *J. Trop. Med. Hyg.* 59 (10), 243–251.
- Smith, C.E., 1956b. Isolation of three strains of type 1 dengue virus from a local outbreak of the disease in Malaya. *J. Hyg. (Lond.)* 54 (4), 569–580.
- Soares, T.S., Rodriguez Gonzalez, B.L., Torquato, R.J.S., Lemos, F.J.A., Costa-da-Silva, A.L., Capurro Guimaraes, M.L., et al., 2018. Functional characterization of a serine protease inhibitor modulated in the infection of the *Aedes aegypti* with dengue virus. *Biochimie* 144, 160–168. Available from: <https://doi.org/10.1016/j.biochi.2017.11.005>.
- Steel, A., Gubler, D.J., Bennett, S.N., 2010. Natural attenuation of dengue virus type-2 after a series of island outbreaks: a retrospective phylogenetic study of events in the South Pacific three decades ago. *Virology* 405 (2), 505–512. Available from: <https://doi.org/10.1016/j.virol.2010.05.033>.
- Stephens, H.A., Klaythong, R., Sirikong, M., Vaughn, D.W., Green, S., Kalayanarooj, S., et al., 2002. HLA-A and -B allele associations with secondary dengue virus infections correlate with disease severity and the infecting viral serotype in ethnic Thais. *Tissue Antigens* 60 (4), 309–318.
- Suaya, J.A., Shepard, D.S., Siqueira, J.B., Martelli, C.T., Lum, L.C., Tan, L.H., et al., 2009. Cost of dengue cases in eight countries in the Americas and Asia: a prospective study. *Am. J. Trop. Med. Hyg.* 80 (5), 846–855.
- Summers, P.L., Eckels, K.H., Dalrymple, J.M., Scott, R.M., Boyd, V.A., 1984. Antibody response to dengue-2 vaccine measured by two different radioimmunoassay methods. *J. Clin. Microbiol.* 19 (5), 651–659.
- Suzuki, R., de Borba, L., Duarte dos Santos, C.N., Mason, P.W., 2007. Construction of an infectious cDNA clone for a Brazilian prototype strain of dengue virus type 1: characterization of a temperature-sensitive mutation in NS1. *Virology* 362 (2), 374–383. Available from: <https://doi.org/10.1016/j.virol.2006.11.026>.
- Suzuki, R., Winkelmann, E.R., Mason, P.W., 2009. Construction and characterization of a single-cycle chimeric flavivirus vaccine candidate that protects mice against lethal challenge with dengue virus type 2. *J. Virol.* 83 (4), 1870–1880. Available from: <https://doi.org/10.1128/JVI.01891-08>.
- Tan, B.H., Fu, J.L., Sugrue, R.J., 2007. Characterization of the dengue virus envelope glycoprotein expressed in *Pichia pastoris*. *Methods Mol. Biol.* 379, 163–176. Available from: [https://doi.org/10.1007/978-1-59745-393-6\\_12](https://doi.org/10.1007/978-1-59745-393-6_12).
- Tan, W.L., Lee, Y.K., Ho, Y.F., Yusof, R., Abdul Rahman, N., Karsani, S.A., 2018. Comparative proteomics reveals that YK51, a 4-Hydroxypandurantin-A analogue, downregulates the expression of proteins associated with dengue virus infection. *PeerJ* 5, e3939. Available from: <https://doi.org/10.7717/peerj.3939>.
- Tapia-Conyer, R., Betancourt-Cravioto, M., Mendez-Galvan, J., 2012a. Dengue: an escalating public health problem in Latin America. *Paediatr. Int. Child Health* 32 (Suppl. 1), 14–17. Available from: <https://doi.org/10.1179/2046904712Z.00000000046>.
- Tapia-Conyer, R., Mendez-Galvan, J., Burciaga-Zuniga, P., 2012b. Community participation in the prevention and control of dengue: the patio limpio strategy in Mexico. *Paediatr. Int. Child Health* 32 (Suppl. 1), 10–13. Available from: <https://doi.org/10.1179/2046904712Z.00000000047>.
- Thepparit, C., Phoolcharoen, W., Suksanpaisan, L., Smith, D.R., 2004. Internalization and propagation of the dengue virus in human hepatoma (HepG2) cells. *Intervirology* 47 (2), 78–86. Available from: <https://doi.org/10.1159/000077830>.

- Turner, C., Witwer, C., Hofacker, I.L., Stadler, P.F., 2004. Conserved RNA secondary structures in Flaviviridae genomes. *J. Gen. Virol.* 85 (Pt 5), 1113–1124. Available from: <https://doi.org/10.1099/vir.0.19462-0>.
- Tricou, V., Minh, N.N., Van, T.P., Lee, S.J., Farrar, J., Wills, B., et al., 2010. A randomized controlled trial of chloroquine for the treatment of dengue in Vietnamese adults. *PLoS Negl. Trop. Dis.* 4 (8), e785. Available from: <https://doi.org/10.1371/journal.pntd.0000785>.
- Tricou, V., Minh, N.N., Farrar, J., Tran, H.T., Simmons, C.P., 2011. Kinetics of viremia and NS1 antigenemia are shaped by immune status and virus serotype in adults with dengue. *PLoS Negl. Trop. Dis.* 5 (9), e1309. Available from: <https://doi.org/10.1371/journal.pntd.0001309>.
- Trung, D.T., Thao le, T.T., Dung, N.M., Ngoc, T.V., Hien, T.T., Chau, N.V., et al., 2012. Clinical features of dengue in a large Vietnamese cohort: intrinsically lower platelet counts and greater risk for bleeding in adults than children. *PLoS Negl. Trop. Dis.* 6 (6), e1679. Available from: <https://doi.org/10.1371/journal.pntd.0001679>.
- Tsai, H.C., Lin, C.C., Hong, N.S., Kuo, T.N., Huang, Y.Y., Lin, M.Y., et al., 2010. Dengue virus infection in early gestation with delivery of an unaffected fetus and no vertical transmission. *Taiwan J. Obstet. Gynecol.* 49 (1), 112–114. Available from: [https://doi.org/10.1016/S1028-4559\(10\)60023-X](https://doi.org/10.1016/S1028-4559(10)60023-X).
- Uchil, P.D., Satchidanandam, V., 2003. Architecture of the flaviviral replication complex. Protease, nuclease, and detergents reveal encasement within double-layered membrane compartments. *J. Biol. Chem.* 278 (27), 24388–24398. Available from: <https://doi.org/10.1074/jbc.M301717200>.
- Umareddy, I., Chao, A., Sampath, A., Gu, F., Vasudevan, S.G., 2006. Dengue virus NS4B interacts with NS3 and dissociates it from single-stranded RNA. *J. Gen. Virol.* 87 (Pt 9), 2605–2614. Available from: <https://doi.org/10.1099/vir.0.81844-0>.
- Uzcategui, N.Y., Comach, G., Camacho, D., Salcedo, M., Cabello de Quintana, M., Jimenez, M., et al., 2003. Molecular epidemiology of dengue virus type 3 in Venezuela. *J. Gen. Virol.* 84 (Pt 6), 1569–1575. Available from: <https://doi.org/10.1099/vir.0.18807-0>.
- Vasilakis, N., Fokam, E.B., Hanson, C.T., Weinberg, E., Sall, A.A., Whitehead, S.S., et al., 2008. Genetic and phenotypic characterization of sylvatic dengue virus type 2 strains. *Virology* 377 (2), 296–307. Available from: <https://doi.org/10.1016/j.virol.2008.04.044>.
- Vaughn, D.W., Green, S., Kalayanarooj, S., Innis, B.L., Nimmannitya, S., Suntayakorn, S., et al., 1997. Dengue in the early febrile phase: viremia and antibody responses. *J. Infect. Dis.* 176 (2), 322–330.
- Vazquez, S., Bravo, J.R., Perez, A.B., Guzman, M.G., 1997. Inhibition ELISA. Its utility for classifying a case of dengue. *Rev. Cubana Med. Trop.* 49 (2), 108–112.
- Vazquez, S., Perez, A.B., Ruiz, D., Rodriguez, R., Pupo, M., Calzada, N., et al., 2005. Serological markers during dengue 3 primary and secondary infections. *J. Clin. Virol.* 33 (2), 132–137. Available from: <https://doi.org/10.1016/j.jcv.2004.10.013>.
- Velzing, J., Groen, J., Drouet, M.T., van Amerongen, G., Copra, C., Osterhaus, A.D., et al., 1999. Induction of protective immunity against dengue virus type 2: comparison of candidate live attenuated and recombinant vaccines. *Vaccine* 17 (11–12), 1312–1320.
- Villordo, S.M., Gamarnik, A.V., 2009. Genome cyclization as strategy for flavivirus RNA replication. *Virus Res.* 139 (2), 230–239. Available from: <https://doi.org/10.1016/j.virusres.2008.07.016>.
- Villordo, S.M., Alvarez, D.E., Gamarnik, A.V., 2010. A balance between circular and linear forms of the dengue virus genome is crucial for viral replication. *RNA* 16 (12), 2325–2335. Available from: <https://doi.org/10.1261/rna.2120410>.
- Voge, N.V., Perera, R., Mahapatra, S., Gresh, L., Balmaseda, A., Lorono-Pino, M.A., et al., 2016. Metabolomics-based discovery of small molecule biomarkers in serum associated

- with dengue virus infections and disease outcomes. *PLoS Negl. Trop. Dis.* 10 (2), e0004449. Available from: <https://doi.org/10.1371/journal.pntd.0004449>.
- Vu, T.T., Holmes, E.C., Duong, V., Nguyen, T.Q., Tran, T.H., Quail, M., et al., 2010. Emergence of the Asian 1 genotype of dengue virus serotype 2 in Viet Nam: in vivo fitness advantage and lineage replacement in South-East Asia. *PLoS Negl. Trop. Dis.* 4 (7), e757. Available from: <https://doi.org/10.1371/journal.pntd.0000757>.
- Wahala, W.M., Silva, A.M., 2011. The human antibody response to dengue virus infection. *Viruses* 3 (12), 2374–2395. Available from: <https://doi.org/10.3390/v3122374>.
- Wang, E., Ni, H., Xu, R., Barrett, A.D., Watowich, S.J., Gubler, D.J., et al., 2000a. Evolutionary relationships of endemic/epidemic and sylvatic dengue viruses. *J. Virol.* 74 (7), 3227–3234.
- Wang, W.K., Lee, C.N., Kao, C.L., Lin, Y.L., King, C.C., 2000b. Quantitative competitive reverse transcription-PCR for quantification of dengue virus RNA. *J. Clin. Microbiol.* 38 (9), 3306–3310.
- Wang, C.C., Lee, I.K., Su, M.C., Lin, H.I., Huang, Y.C., Liu, S.F., et al., 2009. Differences in clinical and laboratory characteristics and disease severity between children and adults with dengue virus infection in Taiwan, 2002. *Trans. R. Soc. Trop. Med. Hyg.* 103 (9), 871–877. Available from: <https://doi.org/10.1016/j.trstmh.2009.04.024>.
- Wani, A.M., Mejally, M.A., Hussain, W.M., Maimani, W.A., Hanif, S., Khoujah, A.M., et al., 2010. Skin rash, headache and abnormal behaviour: unusual presentation of intracranial haemorrhage in dengue fever. *BMJ Case Rep.* 2010. Available from: <https://doi.org/10.1136/bcr.06.2009.1949>.
- Waterman, S.H., Monath, T.P., 1982. Fluorescent antibody techniques applied to the identification of dengue virus in infected tissue. *Acta Virol.* 26 (5), 376–381.
- Webb, C.E., Russell, R.C., 2009. Insect repellents and sunscreens: implications for personal protection strategies against mosquito-borne disease. *Aust. N. Z. J. Public Health* 33 (5), 485–490. Available from: <https://doi.org/10.1111/j.1753-6405.2009.00435.x>.
- Webb, C.E., Russell, R.C., 2012. Does the monomolecular film aquatain mosquito formula provide effective control of container-breeding mosquitoes in Australia?. *J. Am. Mosq. Control. Assoc.* 28 (1), 53–58. Available from: <https://doi.org/10.2987/11-6193.1>.
- Welsch, S., Miller, S., Romero-Brey, I., Merz, A., Bleck, C.K., Walther, P., et al., 2009. Composition and three-dimensional architecture of the dengue virus replication and assembly sites. *Cell Host Microbe* 5 (4), 365–375. Available from: <https://doi.org/10.1016/j.chom.2009.03.007>.
- Wengler, G., Wengler, G., 1981. Terminal sequences of the genome and replicative-from RNA of the flavivirus West Nile virus: absence of poly(A) and possible role in RNA replication. *Virology* 113 (2), 544–555.
- Were, F., 2012. The dengue situation in Africa. *Paediatr. Int. Child Health* 32 (Suppl. 1), 18–21. Available from: <https://doi.org/10.1179/2046904712Z.00000000048>.
- Westaway, E.G., Mackenzie, J.M., Kenney, M.T., Jones, M.K., Khromykh, A.A., 1997. Ultrastructure of Kunjin virus-infected cells: colocalization of NS1 and NS3 with double-stranded RNA, and of NS2B with NS3, in virus-induced membrane structures. *J. Virol.* 71 (9), 6650–6661.
- Whalen, R.G., 1996. DNA vaccines for emerging infectious diseases: what if? *Emerg. Infect. Dis.* 2 (3), 168–175. Available from: <https://doi.org/10.3201/eid0203.960302>.
- White, L.J., Parsons, M.M., Whitmore, A.C., Williams, B.M., de Silva, A., Johnston, R.E., 2007. An immunogenic and protective alphavirus replicon particle-based dengue vaccine overcomes maternal antibody interference in weanling mice. *J. Virol.* 81 (19), 10329–10339. Available from: <https://doi.org/10.1128/JVI.00512-07>.
- White, L.J., Sariol, C.A., Mattocks, M.D., Wahala, M.P.B.W., Yingsiwaphat, V., Collier, M. L., et al., 2013. An alphavirus vector-based tetravalent dengue vaccine induces a rapid

- and protective immune response in macaques that differs qualitatively from immunity induced by live virus infection. *J. Virol.* 87 (6), 3409–3424. Available from: <https://doi.org/10.1128/JVI.02298-12>.
- Wilder-Smith, A., Renhorn, K.E., Tissera, H., Abu Bakar, S., Alphey, L., Kittayapong, P., et al., 2012. DengueTools: innovative tools and strategies for the surveillance and control of dengue. *Global Health Action* 5. Available from: <https://doi.org/10.3402/gha.v5i0.17273>.
- Wills, B.A., Oragui, E.E., Dung, N.M., Loan, H.T., Chau, N.V., Farrar, J.J., et al., 2004. Size and charge characteristics of the protein leak in dengue shock syndrome. *J. Infect. Dis.* 190 (4), 810–818. Available from: <https://doi.org/10.1086/422754>.
- Wills, B., Tran, V.N., Nguyen, T.H., Truong, T.T., Tran, T.N., Nguyen, M.D., et al., 2009. Hemostatic changes in Vietnamese children with mild dengue correlate with the severity of vascular leakage rather than bleeding. *Am. J. Trop. Med. Hyg.* 81 (4), 638–644. Available from: <https://doi.org/10.4269/ajtmh.2009.08-0008>.
- Winkler, G., Randolph, V.B., Cleaves, G.R., Ryan, T.E., Stollar, V., 1988. Evidence that the mature form of the flavivirus nonstructural protein NS1 is a dimer. *Virology* 162 (1), 187–196.
- Wu, N., Wang, S.S., Han, G.X., Xu, R.M., Tang, G.K., Qian, C., 1987. Control of *Aedes aegypti* larvae in household water containers by Chinese cat fish. *Bull. World Health Organ.* 65 (4), 503–506.
- Wu, S.J., Lee, E.M., Putvatana, R., Shurtleff, R.N., Porter, K.R., Suharyono, W., et al., 2001. Detection of dengue viral RNA using a nucleic acid sequence-based amplification assay. *J. Clin. Microbiol.* 39 (8), 2794–2798. Available from: <https://doi.org/10.1128/JCM.39.8.2794-2798.2001>.
- Wu, C.F., Wang, S.H., Sun, C.M., Hu, S.T., Syu, W.J., 2003. Activation of dengue protease autocleavage at the NS2B-NS3 junction by recombinant NS3 and GST-NS2B fusion proteins. *J. Virol. Methods* 114 (1), 45–54.
- Wu, H., Bock, S., Snitko, M., Berger, T., Weidner, T., Holloway, S., et al., 2015. Novel dengue virus NS2B/NS3 protease inhibitors. *Antimicrob. Agents Chemother.* 59 (2), 1100–1109. Available from: <https://doi.org/10.1128/AAC.03543-14>.
- Wylie, S.J., Adams, M., Chalam, C., Kreuze, J., Lopez-Moya, J.J., Ohshima, K., et al., 2017. ICTV virus taxonomy profile: potyviridae. *J. Gen. Virol.* 98 (3), 352–354. Available from: <https://doi.org/10.1099/jgv.0.000740>.
- Xie, X., Gayen, S., Kang, C., Yuan, Z., Shi, P.Y., 2013. Membrane topology and function of dengue virus NS2A protein. *J. Virol.* 87 (8), 4609–4622. Available from: <https://doi.org/10.1128/JVI.02424-12>.
- Xu, Z., Anderson, R., Hobman, T.C., 2011. The capsid-binding nucleolar helicase DDX56 is important for infectivity of West Nile virus. *J. Virol.* 85 (11), 5571–5580. Available from: <https://doi.org/10.1128/JVI.01933-10>.
- Yang, H., Li, Z., Lin, H., Wang, W., Yang, J., Liu, L., et al., 2016. A novel dengue virus serotype 1 vaccine candidate based on Japanese encephalitis virus vaccine strain SA14-14-2 as the backbone. *Arch. Virol.* 161 (6), 1517–1526. Available from: <https://doi.org/10.1007/s00705-016-2817-8>.
- Yap, T.L., Xu, T., Chen, Y.L., Malet, H., Egloff, M.P., Canard, B., et al., 2007. Crystal structure of the dengue virus RNA-dependent RNA polymerase catalytic domain at 1.85-angstrom resolution. *J. Virol.* 81 (9), 4753–4765. Available from: <https://doi.org/10.1128/JVI.02283-06>.
- Yeo, K.L., Chen, Y.L., Xu, H.Y., Dong, H., Wang, Q.Y., Yokokawa, F., et al., 2015. Synergistic suppression of dengue virus replication using a combination of nucleoside analogs and nucleoside synthesis inhibitors. *Antimicrob. Agents Chemother.* 59 (4), 2086–2093. Available from: <https://doi.org/10.1128/AAC.04779-14>.

- Yon, C., Teramoto, T., Mueller, N., Phelan, J., Ganesh, V.K., Murthy, K.H., et al., 2005. Modulation of the nucleoside triphosphatase/RNA helicase and 5'-RNA triphosphatase activities of dengue virus type 2 nonstructural protein 3 (NS3) by interaction with NS5, the RNA-dependent RNA polymerase. *J. Biol. Chem.* 280 (29), 27412–27419. Available from: <https://doi.org/10.1074/jbc.M501393200>.
- Yoon, I.K., Getis, A., Aldstadt, J., Rothman, A.L., Tannitisupawong, D., Koenraadt, C.J., et al., 2012. Fine scale spatiotemporal clustering of dengue virus transmission in children and *Aedes aegypti* in rural Thai villages. *PLoS Negl. Trop. Dis.* 6 (7), e1730. Available from: <https://doi.org/10.1371/journal.pntd.0001730>.
- Yu, I.M., Zhang, W., Holdaway, H.A., Li, L., Kostyuchenko, V.A., Chipman, P.R., et al., 2008. Structure of the immature dengue virus at low pH primes proteolytic maturation. *Science* 319 (5871), 1834–1837. Available from: <https://doi.org/10.1126/science.1153264>.
- Zellweger, R.M., Prestwood, T.R., Shresta, S., 2010. Enhanced infection of liver sinusoidal endothelial cells in a mouse model of antibody-induced severe dengue disease. *Cell Host Microbe* 7 (2), 128–139. Available from: <https://doi.org/10.1016/j.chom.2010.01.004>.
- Zeng, W., Halasa-Rappel, Y.A., Baurin, N., Coudeville, L., Shepard, D.S., 2018. Cost-effectiveness of dengue vaccination in ten endemic countries. *Vaccine* 36 (3), 413–420. Available from: <https://doi.org/10.1016/j.vaccine.2017.11.064>.
- Zhang, W., Chipman, P.R., Corver, J., Johnson, P.R., Zhang, Y., Mukhopadhyay, S., et al., 2003. Visualization of membrane protein domains by cryo-electron microscopy of dengue virus. *Nat. Struct. Biol.* 10 (11), 907–912. Available from: <https://doi.org/10.1038/nsb990>.
- Zou, G., Xu, H.Y., Qing, M., Wang, Q.Y., Shi, P.Y., 2011. Development and characterization of a stable luciferase dengue virus for high-throughput screening. *Antiviral Res.* 91 (1), 11–19. Available from: <https://doi.org/10.1016/j.antiviral.2011.05.001>.