



Published in final edited form as:

*Nat Biotechnol.* 2009 December ; 27(12): 1139–1150. doi:10.1038/nbt.1591.

## Next-Generation Synthetic Gene Networks

Timothy K. Lu<sup>1,2,3</sup>, Ahmad S. Khalil<sup>3</sup>, and James J. Collins<sup>3,4</sup>

<sup>1</sup>Department of Electrical Engineering and Computer Science, Massachusetts Institute of Technology, 77 Massachusetts Ave, Room 38-401, Cambridge, MA 02139, USA.

<sup>2</sup>Harvard-MIT Health Sciences and Technology, 77 Massachusetts Avenue, Room E25-519, Cambridge, MA 02139, USA.

<sup>3</sup>Howard Hughes Medical Institute, Department of Biomedical Engineering, Center for BioDynamics, and Center for Advanced Biotechnology, Boston University, Boston, MA 02215, USA.

<sup>4</sup>Wyss Institute for Biologically Inspired Engineering, Harvard University, Boston, MA 02115, USA

### Abstract

Synthetic biology is focused on the rational construction of biological systems based on engineering principles. During the field's first decade of development, significant progress has been made in designing biological parts and assembling them into genetic circuits to achieve basic functionalities. These circuits have been used to construct proof-of-principle systems with promising results in industrial and medical applications. However, advances in synthetic biology have been limited by a lack of interoperable parts, techniques for dynamically probing biological systems, and frameworks for the reliable construction and operation of complex, higher-order networks. Here, we highlight challenges and goals for next-generation synthetic gene networks, in the context of potential applications in medicine, biotechnology, bioremediation, and bioenergy.

---

Ten years since the introduction of the field's inaugural devices—the genetic toggle switch<sup>1</sup> and repressilator<sup>2</sup>—synthetic biologists have successfully engineered a wide range of functionality into artificial gene circuits, creating switches<sup>1, 3–9</sup>, oscillators<sup>2, 10–12</sup>, digital logic evaluators<sup>13, 14</sup>, counters<sup>9</sup>, filters<sup>15–17</sup>, sensors<sup>18–20</sup>, and cell-cell communicators<sup>15, 19</sup>. Some of these engineered gene networks have been applied to perform useful tasks such as population control<sup>21</sup>, decision-making for whole-cell biosensors<sup>19</sup>, genetic timing for fermentation processes<sup>22</sup>, and image processing<sup>23–25</sup>. Synthetic biologists have even begun to address important medical and industrial problems with engineered organisms such as bacteria that invade cancer cells<sup>26</sup>, engineered bacteriophages that break up biofilms<sup>27</sup> or enhance antibiotic treatments<sup>28</sup>, and synthetic microbial pathways that enable the production of antimalarial drug precursors<sup>29</sup>. However, in most application-driven cases, engineered organisms only contain simple gene circuits that do not fully utilize the potential of synthetic biology. There remains a fundamental

---

Users may view, print, copy, and download text and data-mine the content in such documents, for the purposes of academic research, subject always to the full Conditions of use:[http://www.nature.com/authors/editorial\\_policies/license.html#terms](http://www.nature.com/authors/editorial_policies/license.html#terms)

Correspondence should be addressed to T.K.L. (timlu@mit.edu).

disconnect between low-level genetic circuitry and the promise of assembling these circuits into more complex gene networks that exhibit robust, predictable behaviors.

Thus, despite all of its successes, many more challenges remain in advancing synthetic biology to the realm of higher-order networks with programmable functionality and real-world applicability. Here, instead of reviewing the progress that has been made in synthetic biology to date, we present challenges and goals for next-generation synthetic gene networks, and describe some of the more compelling circuits to be developed and application areas to be considered.

## SYNTHETIC GENE NETWORKS: WHAT HAVE WE LEARNED AND WHAT DO WE NEED?

The engineering of mechanical, electrical, and chemical systems is enabled by well-established frameworks for handling complexity, reliable means of probing and manipulating system states, and the use of testing platforms – tools that are largely lacking in the engineering of biology. Developing properly functioning biological circuits can involve complicated protocols for DNA construction, rudimentary model-guided and rational design, and repeated rounds of trial and error followed by fine-tuning. Limitations in characterizing kinetic processes and interactions between synthetic components and other unknown constituents *in vivo* make troubleshooting and modeling frustrating and prohibitively time-consuming. As a result, the design cycle for engineering synthetic gene networks remains slow and error-prone.

Fortunately, advances are being made in streamlining the physical construction of artificial biological systems, in the form of resources and methods for building larger engineered DNA systems from smaller defined parts<sup>22, 30–32</sup>. Additionally, large-scale DNA sequencing and synthesis technologies are gradually enabling researchers to directly program whole genes, genetic circuits, and even genomes, as well as to re-encode DNA sequences with optimal codons and minimal restriction sites (see “Genome Engineering” on p.XX of this issue<sup>33</sup>).

Despite these advances in molecular construction, the task of building synthetic gene networks that function as desired remains extremely challenging. Accelerated, large-scale diversification<sup>34</sup> and the use of characterized component libraries in conjunction with *in silico* models for *a priori* design<sup>22</sup> are proving useful in helping to fine-tune network performance toward desired outputs. However, in general, synthetic biologists are often fundamentally limited by a dearth of interoperable and modular biological parts, predictive computational modeling capabilities, reliable means of characterizing information flow through engineered gene networks, and test platforms for rapidly designing and constructing synthetic circuits.

In the following subsections, we discuss four important research efforts that will improve and accelerate the design cycle for next-generation synthetic gene networks: (1) advancing and expanding the toolkit of available parts and modules, (2) modeling and fine-tuning the behavior of synthetic circuits, (3) developing probes for reliably quantifying state values for

synthetic (and natural) biomolecular systems, and (4) creating test platforms for characterizing component interactions within engineered gene networks, designing gene circuits with increasing complexity, and developing complex circuits for use in higher organisms. These advances will allow synthetic biologists to realize higher-order networks with desired functionalities for satisfying real-world applications.

### Interoperable Parts and Modules for Synthetic Gene Networks

While there has been no shortage of novel circuit topologies to construct, limitations in the number of interoperable and well-characterized parts have constrained the development of more complex biological systems<sup>22, 31, 35, 36</sup>. The situation is complicated by the fact that many potential interactions between biological parts, which are derived from a variety of sources within different cellular backgrounds, are not well understood or characterized. As a result, the majority of synthetic circuits are still constructed *ad hoc* from a small number of commonly used components (e.g., LacI, TetR, and lambda repressor proteins and regulated promoters) with a significant amount of trial and error. There is a pressing need to expand the synthetic biology toolkit of available parts and modules. Since physical interconnections cannot be made in biological systems to the same extent as electrical and mechanical systems, interoperability must be derived from chemical specificity between parts and their desired targets. This limits our ability to construct truly modular parts and highlights the need for rigorous characterization of component interactions so that detrimental interactions can be minimized and factored into computational models.

Engineered zinc fingers constitute a flexible system for targeting specific DNA sequences, one which could significantly expand the available synthetic biology toolkit for performing targeted recombination, controlling transcriptional activity, and making circuit interconnections. Zinc-finger technology has primarily been used to design zinc-finger nucleases that generate targeted double-strand breaks for genomic modifications<sup>37</sup>. These engineered nucleases may be used to enhance recombination in large-scale genome engineering techniques<sup>34</sup>. A second and potentially very promising use of engineered zinc fingers is as a source of interoperable transcription factors, which would greatly expand the current and limited repertoire of useful activators and repressors. In fact, zinc fingers have already been harnessed to create artificial transcription factors by fusing zinc-finger proteins with activation or repression domains<sup>38, 39</sup>. Libraries of externally controllable transcriptional activators or repressors could be created by engineering protein or RNA ligand-responsive regulators, which control the transcription or translation of zinc finger-based artificial transcription factors themselves<sup>18</sup>. These libraries would enable the construction of basic circuits, such as genetic switches<sup>1</sup>, as well as more complex gene networks. In fact, several of the higher-order networks we describe below rely on having multiple reliable and interoperable transcriptional activators and repressors for proper functioning.

However, these engineered transcription factors have not yet been fully characterized, and if they are to be used as building blocks for complex gene networks, then knowledge of their *in vivo* kinetics and input-output transfer functions would be beneficial. Additionally, much of the rich dynamics associated with small, synthetic gene networks is attributable to the

cooperative binding or multimerization of transcription factors, and it is not yet clear what further engineering is required to endow zinc-finger transcription factors with such features.

Nucleic-acid-based parts, such as RNAs, are also promising candidates for libraries of interoperable parts, since they can be rationally programmed based on sequence specificity<sup>7, 40, 41</sup>. Novel circuit interconnections could be established by using small, interfering RNAs to control the transcription or translation of specific components. Recombinases, which target specific DNA recombinase-recognition sites, also represent a fruitful, underutilized source of interoperable parts. Recombinases have been used in the context of synthetic biology to create memory elements and genetic counters<sup>9</sup>. However, there are over 100 known, natural recombinases, and these can be engineered via mutagenesis and directed evolution for greater diversity and sequence specificity<sup>42–45</sup>.

Libraries of well-characterized, interoperable parts such as transcription factors and recombinases would vastly enhance the ability of synthetic biologists to build more complex gene networks with greater reliability and real-world applicability. In addition to libraries of individual parts, it would be of great value to have well-characterized and interoperable modules (e.g., switches, oscillators, interfaces, etc.) that could be used in a plug-and-play fashion to create higher-order networks and programmable cells. As the number of parts and modules expands, high-throughput, combinatorial efforts for quantifying the levels of interference and crosstalk between multiple components within cells will be increasingly important as guides for choosing the most appropriate components for network assembly.

### Modeling and Fine-Tuning Synthetic Gene Networks

Integrated efforts for modeling and fine-tuning synthetic gene circuits are useful for ensuring that assembled networks operate as intended. Such approaches will be increasingly important as more complex circuits are constructed along with the expanded development of interoperable parts. While studies have shown that in some cases, component properties alone are sufficient for predicting network behavior<sup>22, 31, 46</sup>, others have demonstrated the need for modeling and fine-tuning networks after their basic topologies have been established<sup>1, 22</sup>. A multi-step design cycle that involves creating diverse component libraries, constructing, characterizing, and modeling representative network topologies, assembling and fine-tuning desired circuits, followed by subsequent refinement cycles<sup>22</sup>, will be crucial for the successful design and construction of next-generation synthetic gene networks.

The fine-tuning of biomolecular parts and networks can be achieved by developing diverse component libraries via mutagenesis followed by in-depth characterization and modeling<sup>22, 47–51</sup>. Significant progress has been made in tuning gene expression by altering transcriptional, translational, and degradation activities. For example, promoter libraries with a range of transcriptional activities can be created and characterized, plugged into *in silico* models, and then used to develop synthetic gene networks with defined outputs, without significant post-hoc adjustments<sup>22, 47–51</sup>. Alternatively, synthetic ribosome binding site (RBS) sequences can be used to optimize protein expression levels. Recently, Salis *et al.* developed a thermodynamic model for predicting the relative translational initiation rates for a protein with different upstream RBS sequences, a model that can also be

used to rationally forward-engineer RBS sequences to give desired protein expression<sup>52</sup>. Additionally, protein degradation can be controlled by tagging proteins with degradation-targeting peptides that impart different degradation dynamics<sup>53</sup>.

By automating the construction and characterization of biomolecular components, extensive libraries could be created for the rapid design and construction of complex gene networks. These efforts, coupled with *in silico* modeling, would serve to fast-track synthetic biology. A detailed discussion of modeling techniques for synthetic biology is beyond the scope of this article<sup>22, 31, 54–57</sup>. However, to build reliable models of biomolecular parts and networks, new methods for probing and acquiring detailed *in vitro* and *in vivo* measurements are needed, as will be discussed below.

### Probes for Characterizing Synthetic Gene Networks

Significant advances have been made in the development of new technologies for manipulating biological systems and probing their internal states. At the single-molecule level, for instance, optical tweezers and atomic force microscopes provide new, direct ways to probe the biophysical states of single DNA, RNA, and protein molecules as they undergo conformational changes and other dynamical processes<sup>58–62</sup>. However, we lack similar tools for tracking the *in vivo* operation of synthetic gene circuits in a high-throughput fashion. Ideally, making dynamical measurements of biological networks would involve placing sensors at multiple internal nodes, akin to how current and voltage are measured in electrical systems. Furthermore, external manipulation of synthetic biomolecular systems is typically accomplished by the addition of chemical inducers, which can suffer from crosstalk<sup>63</sup>, be difficult to remove, and be consumed over time. As a result, inputs are often troublesome to control dynamically.

Microfluidic devices have been coupled to single-cell microscopy and image processing techniques to enable increasingly precise manipulation and measurement of cells, especially since inputs can be modulated over time<sup>64, 65</sup>. These systems allow for the rapid addition and removal of chemical inducers, enabling more sophisticated, time-dependent inputs than conventional step functions, while also enabling researchers to track and quantify single cells for long periods of time. These developments make possible the wider use of well-established engineering approaches for analyzing circuits and other systems in synthetic biology. For example, frequency-domain analysis, a technique used commonly in electrical engineering<sup>66, 67</sup>, can be utilized with microfluidics to characterize the transfer functions and noise behaviors of synthetic biological circuits<sup>66–68</sup>. Small-signal linearization of nonlinear gene circuits can be achieved by applying oscillatory perturbations with microfluidics and measuring responses at the single-cell level<sup>67, 68</sup>.

Indeed, microfluidics provides a useful platform for perturbing synthetic gene circuits with well-controlled inputs and observing the outputs in high-resolution fashion. However, without the proper “sensors” (i.e., for quantitatively and simultaneously probing all the internal nodes of a given gene circuit), this technology alone is not sufficient to bring full, engineering-like characterization to synthetic gene networks.

Thus far, probes enabling quantitative measurements of synthetic gene circuits have primarily focused on the transcriptome, such as the use of fluorescent proteins for *in vivo* quantification of promoter activity or protein expression. With the advent of novel mass spectrometry-based methods that provide global, absolute protein concentrations in cells<sup>69</sup>, quantitative transcriptome data can now be merged with proteome data, improving our ability to characterize and model the dynamics of synthetic gene networks. Global proteomic data may also assist synthetic biologists in understanding the metabolic burden that artificial circuits place on host cells. Further efforts to devise fluorescent-based and other reporters for the simultaneous monitoring of transcriptome and proteome dynamics *in vivo* are needed to close the loop on full circuit accounting. Some promising tools under development include tracking protein function by incorporating unnatural amino acids that exhibit fluorescence<sup>70, 71</sup>, quantum dots<sup>72</sup>, and radiofrequency-controlled nanoparticles<sup>73</sup>.

As the field awaits entire-circuit probes, there are, in the meantime, several potentially accessible technologies for increasing the throughput and pace of piecewise gene-circuit characterization. Recent advances in engineering light-inducible biological parts and systems<sup>23, 24, 74</sup> have unlocked the potential for optical-based circuit characterization, expanding the number and type of tunable knobs available to synthetic biologists. For instance, by coupling a synthetic gene network of interest to a biological light/dark sensor as well as to fluorescent protein outputs, one could potentially measure the network's input/output transfer function in a high-throughput fashion using spectrophotometric microplate readers, without having to add varying concentrations of chemical inducers. In essence, both control and monitoring of biomolecular systems would be accomplished using reliable and high-speed optics that are typically associated with fluorescence readouts and microscopy. This is an exciting prospect, particularly in the context of microfluidic devices, which would facilitate the focusing of optical inputs and readouts to single cells.

Using electrical signals, in lieu of chemical or optical signals, for biological system control and monitoring would also present high-speed advantages. Recently, advances were made in integrating silicon electronics with lipid bilayers containing transmembrane pores to perform electronic signal conduction<sup>75</sup>. This technology may eventually allow direct communication and control between engineered cells and electronic circuits via ionic flow. The incorporation of these and other technologies to perturb and monitor the *in vivo* performance of synthetic gene networks will enable us to achieve desired functionality faster and more reliably.

### **Test Platforms for Engineering Complex Gene Circuits**

Increasing complexity, be it by assembling larger synthetic gene networks from smaller ones or by engineering circuits into higher organisms, dramatically increases the number of potential failure modes. In the former case, combining multiple individually-functioning genetic circuits into a single cellular background can lead to unintended interactions among the synthetic components or with host factors, and these various failure modes are often difficult to pinpoint and isolate from one another. In the latter case, engineering synthetic networks for mammalian systems poses additional challenges beyond engineering circuits for bacterial and yeast strains, which have reasonably well-characterized genomes,

transcriptomes, proteomes, and metabolomes. Mammalian systems are much more complex and possess substantially less well-characterized components for engineering<sup>76</sup>, but for these and other reasons, constitute fertile ground for new applications and genetic parts.

The development of test platforms where engineered gene circuits can be designed and validated prior to being deployed in other or more complex cellular backgrounds would mitigate failure-prone jumps in complexity. These platforms could be used to verify or debug circuit topology and basic functionality in well-controlled environments. For example, cells optimized for testing may be engineered to have minimal genomes to decrease the risk of pleiotropic or uncharacterized interactions between the host and the synthetic networks<sup>77–81</sup>. The use of orthogonal parts that are decoupled from host cells may enable the dedication of defined cellular resources to engineered functions, which can simplify the construction and troubleshooting of gene circuits. For example, nucleic-acid-based parts can be designed to function orthogonally to the wild-type cellular machinery<sup>82–84</sup>. Artificial codons and unnatural amino acids, which have enabled new methods for studying existing proteins and the realization of proteins with novel functions, could also be used to produce synthetic circuits that function orthogonally to host cells<sup>85</sup>. Simplifying backgrounds would additionally enable more accurate computational modeling of complex circuits before they are deployed into their ultimate environments. Furthermore, minimal cells could themselves contain synthetic circuits that provide useful testing functionalities, such as multiplexed transcriptional and translational controls and output probes.

Lower organisms can also be useful for the construction and characterization of synthetic gene networks before such systems are extended and deployed into higher organisms. In fact, several synthetic circuits, such as clocks and switches, were initially developed in bacteria and later translated into mammalian counterparts using analogous design principles<sup>3, 7, 12</sup>. Additionally, lower-organism test platforms could be endowed with certain features of interest from desired higher-organism host. For example, RNA-interference-based circuits could be built first in *Saccharomyces cerevisiae* prior to being used in mammalian cells<sup>86</sup>. In one case, mitochondrial DNA was engineered into *Escherichia coli* prior to retransplantation into mammalian hosts<sup>87</sup>. Other biomolecular systems and components that are ripe for engineering in lower organisms include chromatin, ubiquitins, and proteosomes.

The introduction of synthetic gene networks into higher organisms also runs the risk of compromising natural networks, which have evolved to maintain cellular robustness. Accordingly, methods for simplifying organisms for designing and testing synthetic circuits could be extended to engineer final deployment hosts, making them more conducive to synthetic gene circuits. Ultimately, *in vivo* directed evolutionary methods, based on repeated rounds of mutagenesis and selection within final cellular backgrounds, could be used to identify the optimal performance conditions of synthetic gene networks after their basic functionalities have been validated in earlier test platforms<sup>34</sup>.

## NEXT-GENERATION GENE NETWORKS

Advancing synthetic gene circuits into the realm of higher-order networks with programmable functionality is one of the ultimate goals of synthetic biology. Useful next-generation gene networks should attempt to satisfy at least one of the following criteria: (1) yielding insights into the principles that guide the operation of natural biological systems; (2) highlighting design principles and/or providing modules that can be applied to the construction of other useful synthetic circuits; (3) advancing the tools available for novel scientific experiments; and (4) enabling real-world applications in medicine, industry, and agriculture. Below, we describe several next-generation gene circuits and discuss their potential utility in the context of the above criteria.

### Tunable Filters and Noise Generators

Fine-tuning the performance of a synthetic gene network typically means re-engineering its components, be it by replacing or mutating its parts. Networks whose responses can be tuned without the re-engineering of its parts, such as the biological version of a tunable electronic filter, would enable more sophisticated cellular-based signal processing. Synthetic transcriptional cascades can exhibit low-pass filter characteristics<sup>16</sup>, and artificial gene circuits with negative autoregulation are capable of pushing the noise spectra of their output to higher frequencies, where it can be filtered by the low-pass characteristics of a downstream gene cascade<sup>88</sup>. Tunable genetic filters with respect to time could be implemented by tuning RNA and/or protein degradation in autoregulated negative feedback circuits<sup>66, 89–91</sup> (Fig. 1). Such circuits would be useful in studying and shaping noise spectra to optimize the performance of artificial gene networks.

Recently, an externally tunable, bacterial bandpass-filter was described<sup>17</sup> which uses low-pass and high-pass filters in series to derive bandpass activity with respect to enzymes and inducer molecules. These types of filters, when coupled to quorum-sensing modules, can be used for spatial patterning applications<sup>15, 17</sup>. They could also be readily extended to complex multicellular pattern formation, by engineering a suite of different cells, each carrying filters that respond to different inputs. Synthetic gene circuits based on tunable filters may also make useful platforms for studying cellular differentiation and development, as artificial pattern generation is a model for how natural systems form complex structures<sup>15, 17</sup>.

Along similar lines, recent developments in stem cell biology have unlocked important potential roles for synthetic gene networks<sup>92</sup>. For example, it has been shown that stochastic fluctuations in protein expression in embryonic stem cells are important for determining differentiation fates<sup>93</sup>. Indeed, stochasticity might be harnessed in differentiation to force population-wide heterogeneity and provide system robustness, though it may also be detrimental if it causes uncontrollable differentiation.

The effects of stochasticity in stem cell differentiation could be studied with synthetic gene circuits that act as tunable noise generators. Lu *et al.*, for instance, considered two such designs for modulating the noise profile of an output protein<sup>94</sup>. They showed that the mean value and variance of the output can be effectively tuned with two external signals, one for



regulating transcription and the other for regulating translation, and to a greater extent with three external signals, the third for regulating DNA copy number<sup>94</sup>. By varying noise levels while keeping mean expression levels constant, the thresholds at which gene expression noise yields beneficial versus detrimental effects on stem cell differentiation could be elucidated<sup>95</sup>.

Additionally, the discovery of induced pluripotent stem cells (iPSCs), based on the controlled expression of four transcription factors (OCT4, SOX2, KLF2, MYC) in adult fibroblasts, has created a source of patient-specific progenitor cells for engineering<sup>92</sup>. Genetic noise generators and basic control circuits could be used to dissect the mechanism for inducing pluripotency in differentiated adult cells, by sequentially controlling the expression levels of the four iPSC-dependent transcription factors. Ultimately, these efforts could lead to the development of timing circuits<sup>22</sup> for higher-efficiency stem cell reprogramming.

Lineage commitment to trophectoderm, ectoderm, mesoderm, and endoderm pathways are controlled by distinct sets of genes<sup>93</sup>, and many interacting factors, including growth factors, extracellular matrices, and mechanical forces, play important roles in cellular differentiation<sup>96</sup>. As differentiation pathways become better understood, synthetic gene cascades may be used to program cellular commitment with increased fidelity for applications in biotechnology and regenerative medicine.

### **Analog-to-Digital and Digital-to-Analog Converters**

Electrical engineers have utilized digital processing to achieve reliability and flexibility, even though the world in which digital circuits operate is inherently analog. Although synthetic biological circuits are unlikely to match the computing power of digital electronics, simple circuits inspired by digital and analog electronics may significantly increase the reliability and programmability of biological behaviors.

For example, biological analog-to-digital converters could translate external analog inputs, such as inducer concentrations or exposure times, into internal digital representations for biological processing. Consider, for instance, a bank of genetic switches with adjustable thresholds (Fig. 2a). These switches could be made out of libraries of artificial transcription factors, as described above. This design would perform discretization of analog inputs into levels of digital output. Depending on the level of analog inputs, different genetic pathways could be activated. Cells possessing analog-to-digital converters would be useful as biosensors in medical and environmental settings. For example, whole-cell biosensors<sup>19</sup>, resident in the gut, may be engineered to generate different reporter molecules that could be measured in stool depending on the detected level of gastrointestinal bleeding. Expressing different reporter molecules rather than a continuous gradient of a single reporter molecule would yield more reliable and easily interpretable outputs.

Digital-to-analog converters, on the other hand, would translate digital representations back into analog outputs (Fig. 2b); such systems could be used to reliably set internal system states. For example, instead of fine-tuning transcriptional activity with varying amounts of chemical inducers, a digital-to-analog converter, composed of a bank of genetic switches,

each of which is sensitive to a different inducer, might provide better control. If each activated switch enabled transcription from promoters of varying strengths ( $P_{\text{output},3} > P_{\text{output},2} > P_{\text{output},1}$ ), then digital combinations of inducers could be used to program defined levels of transcriptional activities (Fig. 2b). Such a circuit might be useful in biotechnology applications, where reliable expression of different pathways is needed for programming different modes of operation in engineered cells. In addition, digital-to-analog converters may be useful in providing a multiplexed method for probing synthetic circuits. For example, since each analog level is associated with a distinct digital state, a single analog output can allow one to infer the internal digital state of a synthetic gene network (Fig. 2b).

### Adaptive Learning Networks

Synthetic gene networks that can learn or adapt to exogenous conditions could provide insight into natural networks and be useful for applications where adaptation to external stimuli may be advantageous, such as autonomous whole-cell biosensors<sup>97, 98</sup>. Endogenous biomolecular networks in bacteria can exhibit anticipatory behavior for related perturbations in environmental stimuli<sup>99, 100</sup>. This type of behavior and the associated underlying design principles could, in principle, be harnessed to endow transcriptional networks with the ability to learn<sup>97</sup>, much like synaptic interconnections between neurons. A basic design that would enable this functionality involves two transcriptional activators (Activator A and Activator B), each of which is expressed in the presence of a different stimulus (Fig. 3a). Suppose that both transcriptional activators drive the expression of effector proteins (Effector A and Effector B), which control distinct genetic pathways. When both transcriptional factors are active, indicating the simultaneous presence of the two stimuli, a toggle switch is flipped ON. This creates an associative memory. Subsequently, if either of the transcription factors is activated, AND logic between the ON toggle switch and one transcriptional activator produces the effector protein that controls the pathways of the other activators. Based on this design, cells could be programmed to associate simultaneous inputs and exhibit anticipatory behavior by activating the pathways of associated stimuli, even in the presence of only one of the stimuli.

In another example of a learning network, one could design bacteria that could be taught “winner-take-all” behavior in detecting stimuli, similar to cortical neural processing<sup>101</sup>. In this example, bacteria could be exposed to different types of chemical stimuli (Inducers A–C) (Fig. 3b). An exogenously added inducer (Inducer “Learn”) acts as a trigger for learning and serves as one input into multiple, independent transcriptional AND gates, which possess secondary inputs for detecting the presence of each of the different chemical stimuli. Each gate drives an individual toggle switch that, when flipped, suppresses the flipping of the other switches. This creates a winner-take-all system in which the presence of the most abundant chemical stimuli is recorded. Furthermore, the toggle switch outputs could be fed as inputs into transcriptional AND gates, which once again possess secondary inputs for detecting the presence of the different stimuli. If these gates drive different fluorescent reporters when activated, then the overall system will only associate a single type of stimuli with the learning trigger and respond with an output only in the presence of the single type of stimuli in the future. This system could potentially be adapted to create chemotactic

bacteria that “remember” a particular location or landmark and only respond to the gradient of one chemoattractant.

In more complicated instances of learning networks, it is conceivable that synthetic gene circuits could be designed to adapt on their own, that is, without external mutagenesis or exogenous nucleic acids. For example, transcription-based interconnections could be dynamically reconfigured based on the expression of DNA recombinases<sup>9</sup>. Another design could involve error-prone RNA polymerases, which create mutant RNAs that could be reverse-transcribed and joined back into the genome based on double-stranded breaks created by zinc-finger nucleases. Specificity for where the mutations would occur could be achieved by using promoters that are uniquely read by the error-prone RNA polymerases, such as T7 promoters with a T7 error-prone RNA polymerase, and zinc-finger nucleases that define where homologous recombination can occur<sup>102</sup>. In this design, enhanced mutagenesis frequencies could be targeted to specific regions of the genome.

### Protein-Based Computational Circuits

Beyond DNA- and RNA-based circuits, protein-based synthetic systems have the potential to enable flexible and fast computation via post-translational mechanisms<sup>103–105</sup>. Protein-based circuits are advantageous in that they can be designed to target synthetic activities to subcellular locations<sup>24</sup>. In this way, different sites within the same cell could have different protein circuit states rather than relying solely on shared cellular promoter states, thereby enabling researchers to explore the functional dynamics and consequences of cellular localization. Protein-based designs can also operate on much quicker time scales than genetic circuits because their operation is independent of the transcription and translation machinery<sup>106</sup>. Accordingly, it would be exciting to develop protein-based circuits that can act as rapidly responding logic gates, smart sensors, or memory elements.

With regards to the latter, synthetic amyloids could serve as novel components for epigenetic memory circuits. By fusing a yeast prion determinant from Sup35 to the rat glucocorticoid receptor, a transcription factor regulated by steroid hormone, Li and Lindquist demonstrated that the state of transcriptional activity from the fused protein could be affected and inherited stably in an epigenetic fashion<sup>107</sup>. Given the increasing number of identified prionogenic proteins<sup>108</sup>, there is an opportunity to create amyloid-based memory systems that transmit functionality from one generation to the next (Fig. 4). In these systems, aggregation could be induced by the transient expression of the prionogenic domain (PD), while disaggregation could be achieved by expressing protein remodeling factors such as chaperones (HSP104). Though this system relies on the transcription and translation of prionogenic and disaggregating factors, it may enable the control of protein effectors that can operate on faster time scales. For example, enzymes fused to a prionogenic domain may exhibit different activity levels depending on whether they are attached to an amyloid core.

Since genetic circuits and proteins function on different time scales, it would also be worthwhile to develop synthetic networks that couple both modalities. For example, the output of protein-based computation could be stored in recombinase-based memory elements<sup>5, 6, 9</sup>. It would also be conceivable to couple the two types of networks to harness their varied filtering capabilities. For example, the mitogen-activated protein kinase cascade

contains both positive-feedback and negative-feedback loops that enable rapid activation followed by deactivation<sup>109</sup>, thus acting like a high-pass filter. On the other hand, transcription- and translation-based gene networks operate on slower time scales rendering them effective low-pass filters. Thus, synthetic kinase/phosphatase circuits that in turn drive gene-based networks could be used to create bandstop filters, which could be coupled with other bandpass filters and utilized for complex patterning applications.

### **Intercell Signaling Circuits and Pulse-Based Processing for Genetic Oscillators**

Robust genetic oscillators with tunable periods have been developed via a combination of experimental and computational efforts<sup>11, 12, 110</sup>. In addition to shedding light on the design principles guiding the evolution of naturally-occurring biological clocks and circadian rhythms, these synthetic oscillators may also have significant utility in biotechnology applications, such as in the synthesis and delivery of biologic drugs. Glucocorticoid secretion, for instance, has a circadian and ultradian pattern of release, resulting in transcriptional pulsing in cells that contain glucocorticoid receptors<sup>111</sup>. Therefore, pulsatile administration of hormones may have therapeutic benefit compared with synthetic hormones applied in a non-ultradian schedule.

An alternative to device-based periodic drug delivery systems could be engineered bacteria that reside in the human gut and synthesize an active drug at fixed time intervals. To realize such an application, one would need to develop and implement intercell signaling circuits for synchronizing and entraining synthetic genetic oscillators<sup>112, 113</sup>. Such circuits could be based, for example, on modular components from bacterial quorum sensing systems. Along similar lines, one could engineer light-sensitive<sup>23, 24</sup> entrainment circuits for synchronizing mammalian synthetic genetic oscillators. This may help in the construction of oscillators that can faithfully follow circadian rhythms.

Spike- or pulse-based processing is present in neurons and has been adapted for use in hybrid computation in electrical systems, where interspike times are viewed as analog parameters and spike counts are viewed as digital parameters<sup>114</sup>. In synthetic gene circuits, spike-based processing may open up exciting new methods for encoding information in engineered cells. For example, instead of transmitting information between cells via absolute levels of quorum-sensing molecules, the frequency of a robust genetic oscillator could be modulated. This might be useful in delivering information over longer distances, as frequency information may be less susceptible to decay over distance than absolute molecule levels. Representing signals in this fashion is analogous to frequency modulation encoding in electrical engineering.

### **Engineered Circuits for Biological Containment**

Biological containment, which refers to efforts for ensuring that genetically-modified organisms do not spread throughout the natural environment, can be achieved by passive or active techniques. In passive containment, cells are engineered to be dependent on exogenous supplementation to compensate for gene defects, while in active containment, cells are engineered to directly express toxic compounds when located outside their target environments<sup>115</sup>. Synthetic genetic counters or timers for programmed cell death could be

used as an active containment tool. Counting circuits could, for example, be designed to trigger cell suicide after a defined number of cell cycles or a sequence of events. Recently, we developed two designs for synthetic counters – a recombinase-based cascade of memory units and a riboregulated transcriptional cascade – that could be adapted for this purpose<sup>9</sup>. In each case, one could incorporate into the counters promoters that are cell cycle-dependent and replace the output reporter proteins with toxic proteins (Fig. 5). Circuits of this sort would enable cells to be programmed to have limited, prescribed lifetimes.

Redundant circuits that implement digital logic allowing for the conditional survival of engineered cells only within their desired environments would also potentially reduce the failure rate of biological containment. By developing a broad set of interoperable parts, multiple layers of control circuits could be built for increased reliability. As in electrical and mechanical engineering, quantitative analysis of failure rates in biological systems would enable improved systems-level design and robustness of synthetic gene networks. This could be accomplished, for example, by subjecting synthetic containment circuits to a variety of stressful conditions that would lead to increased mutation rates and thus improper functioning. Rational and directed evolutionary methods to engineer cells with decreased mutation rates or the application of redundant circuits could then be employed to minimize failure rates.

### Whole-Cell Biosensors and Response Systems

Programmable cells that act as whole-cell biosensors have been created by interfacing engineered gene networks with the cell's natural regulatory circuitry<sup>19</sup> or with other biological components such as light-responsive elements<sup>23, 24</sup>. The development of novel or re-engineered sensory modalities and components would expand the range of applications that programmable cells could address. This could involve engineering proteins or RNAs to detect a range of small molecules<sup>116, 117</sup>, or designing protein-based synthetic signaling cascades by rationally rewiring the protein-protein interactions and output responses of prokaryotic two-component signal transduction systems<sup>118</sup>.

The detection of electrical signals or production of biological energy (e.g., mimicking the operation of electrical electrocytes<sup>119</sup>) could also be enabled by incorporating natural or synthetic ion channels into engineered cells. Additionally, magneto-responsive bacteria could play useful roles in environmental and medical applications<sup>120</sup>. Synthetic bacteria, designed to form magnetosomes and seek out cancer cells, could be used to enhance imaging, and magnetic bacteria could be engineered to interact with nanoparticles to enhance the targeting of cancer cells. Moreover, the introduction of mechanosensitive ion channels (such as MscL from *M. tuberculosis* and MscS from *Escherichia coli*) could endow designer cells with the ability to detect mechanical forces<sup>121</sup>. Such cells may be useful *in vivo* sensors for studying cellular differentiation signals or the effects of external stresses on the body.

Ultimately, programmable cells possessing novel sensory modules could be integrated with mechanical, electrical, and chemical systems to detect, process, and respond to external stimuli, and utilized for a variety of environmental and medical applications. For example, bacteria could be engineered to seek out hazardous chemicals or heavy metals in the

environment, perform cleanup, and return to their origin to report on the number of hazardous sites encountered via analysis by microfluidic devices. To eventually achieve such complex tasks, an intermediate goal might involve programming chemotactic bacteria to swim from waypoint to waypoint. A dish containing gradients of several chemoattractants would constitute the navigational course (Fig. 6a).

At the core of this design could be a synthetic gene network made up of a series of sequential toggle switches that control the expression of receptors needed for bacterial chemotaxis towards chemoattractants<sup>122</sup> (Fig. 6b). The programmable cells would initially express only a single chemoattractant receptor, and therefore would migrate up only one of the chemoattractant gradients<sup>122</sup>. To determine that a waypoint has been achieved, a threshold-based toggle switch would be turned ON upon reaching a sufficiently high concentration of the chemoattractant. When the first toggle switch is ON, production of the first chemoattractant receptor would be suppressed and production of a second receptor allowed, resulting in cells swimming up the second chemical gradient. The ON switch would additionally prime the next toggle switch in the series to be switched ON when the second waypoint is reached. When that second toggle flips ON, the previous switch would be flipped OFF to ensure that only one chemoattractant is being followed at a time. The final chemoattractant would lead the bacteria back to its origin so that the engineered cells would complete a multi-stop round trip.

### Designer Circuits and Systems for Microbiome Engineering

The human microbiome is fertile ground for the application of engineered organisms as scientific tools and therapeutic agents. There are unique bacterial populations residing in distinct locations in the human body that are perturbed in disease states<sup>123, 124</sup>. Each represents an exciting opportunity for re-engineering the human microbiome and designing targeted therapeutics for a range of conditions, including dermatologic, genitourinary, gastrointestinal, metabolic, and immunologic diseases<sup>125–127</sup>.

Recently, there have been a number of examples in which engineered bacteria were designed to infiltrate cellular communities for the purposes of delivering probes, gene circuits, or chemicals<sup>128, 129</sup>. In a similar fashion, bacteriophages carrying synthetic gene circuits could transform existing microbiome bacteria with new functionalities. For example, given that anaerobic bacteria are known to migrate to hypoxic and necrotic regions of solid tumors<sup>130</sup>, bacteriophages could be designed to infect cancer-targeting bacteria. These bacteriophages could encode conditional expression of chemotherapeutic agents using synthetic logic gates or switches that are coupled to environmental sensors.

Bhatia and colleagues recently developed nanoparticles that perform Boolean logic based on proteolytic activity<sup>131</sup>. Viruses that infect tumor cells or bacteria could carry synthetic gene circuits that regulate in a programmable fashion the expression of enzymes that trigger nanoparticle activity. In these ways, one could develop targeted therapies against cancer or infectious diseases that exploit the human microbiome and synthetic gene networks.

## Switchboard for Dynamically Controlling the Expression of Multiple Genes

Engineered cells have long been used to produce recombinant proteins and chemicals for the biotechnology industry, and one of the major applications of synthetic biology to date has been in enhancing microbial production of biofuels<sup>132</sup> and biomaterials<sup>133–136</sup>. Improving production from cells involves numerous engineering decisions related to the entire organism, including codon optimization, choosing whether or not to export recombinant proteins<sup>137</sup>, rational or evolutionary methods for improving metabolic yields<sup>138, 139</sup>, and optimization of growth conditions. Often some or all of the genes required for production are non-optimal for bacterial expression and contain repetitive sequences that are unstable in bacterial hosts. Whole-gene synthesis techniques are increasingly being used to optimize coding sequences for recombinant production<sup>136</sup>.

These innovative approaches, as well as more traditional knockout techniques, introduce hard-wired changes into the genomes of interest. However, for many industrial and bioprocess applications, there is a need to dynamically modulate and control the expression of multiple genes, depending upon the state of the bioreactor. These situations would benefit from the development of a synthetic switchboard, one that could tune the expression of many different genes simultaneously and independently. Such a switchboard could be made up of a series of adjustable threshold genetic switches, riboregulators, or riboswitches, and designed to respond to different environmental and intracellular variables, such as pH, light intensity, and the metabolic state of the cell. The switchboard design, which would integrate novel sensory modalities with tunable, interoperable genetic circuits, would have broad functionality for the biotechnology industry. It could be programmed, for example, to shift carbon flux between different pathways depending upon cellular conditions, thereby optimizing the production of biofuels, specialty chemicals, and other materials.

## CONCLUSIONS

In the last decade, we have witnessed the power of intelligently applying engineering principles to biology in the development of many exciting, artificial gene circuits and biomolecular systems. Next-generation synthetic gene networks will advance our understanding of natural systems, provide new biological modules and tools for enabling the construction of even more complex systems, and perhaps most importantly, satisfy real-world applications in fields such as medicine, biotechnology, bioremediation, and bioenergy.

## Acknowledgments

We would like to thank the Howard Hughes Medical Institute and the NIH Director's Pioneer Award Program for their financial support. We greatly appreciate the opportunity from the editors to write about our perspectives on the future of synthetic biology. We also thank the editors and anonymous reviewers for their insights and suggestions.

## References

1. Gardner TS, Cantor CR, Collins JJ. Construction of a genetic toggle switch in *Escherichia coli*. *Nature*. 2000; 403:339–342. [PubMed: 10659857]
2. Elowitz MB, Leibler S. A synthetic oscillatory network of transcriptional regulators. *Nature*. 2000; 403:335–338. [PubMed: 10659856]

3. Kramer BP, et al. An engineered epigenetic transgene switch in mammalian cells. *Nat Biotechnol.* 2004; 22:867–870. [PubMed: 15184906]
4. Isaacs FJ, Hasty J, Cantor CR, Collins JJ. Prediction and measurement of an autoregulatory genetic module. *Proc Natl Acad Sci U S A.* 2003; 100:7714–7719. [PubMed: 12808135]
5. Ham TS, Lee SK, Keasling JD, Arkin AP. A tightly regulated inducible expression system utilizing the fim inversion recombination switch. *Biotechnol Bioeng.* 2006; 94:1–4. [PubMed: 16534780]
6. Ham TS, Lee SK, Keasling JD, Arkin AP. Design and construction of a double inversion recombination switch for heritable sequential genetic memory. *PLoS ONE.* 2008; 3:e2815. [PubMed: 18665232]
7. Deans TL, Cantor CR, Collins JJ. A tunable genetic switch based on RNAi and repressor proteins for regulating gene expression in mammalian cells. *Cell.* 2007; 130:363–372. [PubMed: 17662949]
8. Ajo-Franklin CM, et al. Rational design of memory in eukaryotic cells. *Genes Dev.* 2007; 21:2271–2276. [PubMed: 17875664]
9. Friedland AE, et al. Synthetic gene networks that count. *Science.* 2009; 324:1199–1202. [PubMed: 19478183]
10. Fung E, et al. A synthetic gene-metabolic oscillator. *Nature.* 2005; 435:118–122. [PubMed: 15875027]
11. Stricker J, et al. A fast, robust and tunable synthetic gene oscillator. *Nature.* 2008; 456:516–519. [PubMed: 18971928]
12. Tigges M, Marquez-Lago TT, Stelling J, Fussenegger M. A tunable synthetic mammalian oscillator. *Nature.* 2009; 457:309–312. [PubMed: 19148099]
13. Rinaudo K, et al. A universal RNAi-based logic evaluator that operates in mammalian cells. *Nat Biotechnol.* 2007; 25:795–801. [PubMed: 17515909]
14. Win MN, Smolke CD. Higher-order cellular information processing with synthetic RNA devices. *Science.* 2008; 322:456–460. [PubMed: 18927397]
15. Basu S, Gerchman Y, Collins CH, Arnold FH, Weiss R. A synthetic multicellular system for programmed pattern formation. *Nature.* 2005; 434:1130–1134. [PubMed: 15858574]
16. Hooshangi S, Thiberge S, Weiss R. Ultrasensitivity and noise propagation in a synthetic transcriptional cascade. *Proc Natl Acad Sci U S A.* 2005; 102:3581–3586. [PubMed: 15738412]
17. Sohka T, et al. An externally tunable bacterial band-pass filter. *Proc Natl Acad Sci U S A.* 2009; 106:10135–10140. [PubMed: 19502423]
18. Bayer TS, Smolke CD. Programmable ligand-controlled riboregulators of eukaryotic gene expression. *Nat Biotechnol.* 2005; 23:337–343. [PubMed: 15723047]
19. Kobayashi H, et al. Programmable cells: interfacing natural and engineered gene networks. *Proc Natl Acad Sci U S A.* 2004; 101:8414–8419. [PubMed: 15159530]
20. Win MN, Smolke CD. A modular and extensible RNA-based gene-regulatory platform for engineering cellular function. *Proc Natl Acad Sci U S A.* 2007; 104:14283–14288. [PubMed: 17709748]
21. You L, Cox RS 3rd, Weiss R, Arnold FH. Programmed population control by cell-cell communication and regulated killing. *Nature.* 2004; 428:868–871. [PubMed: 15064770]
22. Ellis T, Wang X, Collins JJ. Diversity-based, model-guided construction of synthetic gene networks with predicted functions. *Nat Biotechnol.* 2009; 27:465–471. [PubMed: 19377462]
23. Levskaya A, et al. Synthetic biology: engineering *Escherichia coli* to see light. *Nature.* 2005; 438:441–442. [PubMed: 16306980]
24. Levskaya A, Weiner OD, Lim WA, Voigt CA. Spatiotemporal control of cell signalling using a light-switchable protein interaction. *Nature.* 2009
25. Tabor JJ, et al. A synthetic genetic edge detection program. *Cell.* 2009; 137:1272–1281. [PubMed: 19563759]
26. Anderson JC, Clarke EJ, Arkin AP, Voigt CA. Environmentally controlled invasion of cancer cells by engineered bacteria. *J Mol Biol.* 2006; 355:619–627. [PubMed: 16330045]
27. Lu TK, Collins JJ. Dispersing biofilms with engineered enzymatic bacteriophage. *Proc Natl Acad Sci U S A.* 2007; 104:11197–11202. [PubMed: 17592147]



28. Lu TK, Collins JJ. Engineered bacteriophage targeting gene networks as adjuvants for antibiotic therapy. *Proc Natl Acad Sci U S A*. 2009; 106:4629–4634. [PubMed: 19255432]
29. Ro DK, et al. Production of the antimalarial drug precursor artemisinic acid in engineered yeast. *Nature*. 2006; 440:940–943. [PubMed: 16612385]
30. Czar MJ, Cai Y, Peccoud J. Writing DNA with GenoCAD. *Nucleic Acids Res*. 2009; 37:W40–W47. [PubMed: 19429897]
31. Guido NJ, et al. A bottom-up approach to gene regulation. *Nature*. 2006; 439:856–860. [PubMed: 16482159]
32. Shetty RP, Endy D, Knight TF Jr. Engineering BioBrick vectors from BioBrick parts. *J Biol Eng*. 2008; 2:5. [PubMed: 18410688]
33. Carr PA, Church GM. Genome Engineering. *Nat Biotechnol*. 2009; 27
34. Wang HH, et al. Programming cells by multiplex genome engineering and accelerated evolution. *Nature*. 2009; 460:894–898. [PubMed: 19633652]
35. Purnick PE, Weiss R. The second wave of synthetic biology: from modules to systems. *Nat Rev Mol Cell Biol*. 2009; 10:410–422. [PubMed: 19461664]
36. Lucks JB, Qi L, Whitaker WR, Arkin AP. Toward scalable parts families for predictable design of biological circuits. *Curr Opin Microbiol*. 2008; 11:567–573. [PubMed: 18983935]
37. Maeder ML, et al. Rapid "open-source" engineering of customized zinc-finger nucleases for highly efficient gene modification. *Mol Cell*. 2008; 31:294–301. [PubMed: 18657511]
38. Beerli RR, Dreier B, Barbas CF 3rd. Positive and negative regulation of endogenous genes by designed transcription factors. *Proc Natl Acad Sci U S A*. 2000; 97:1495–1500. [PubMed: 10660690]
39. Park KS, et al. Phenotypic alteration of eukaryotic cells using randomized libraries of artificial transcription factors. *Nat Biotechnol*. 2003; 21:1208–1214. [PubMed: 12960965]
40. Isaacs FJ, et al. Engineered riboregulators enable post-transcriptional control of gene expression. *Nat Biotechnol*. 2004; 22:841–847. [PubMed: 15208640]
41. Win MN, Liang JC, Smolke CD. Frameworks for programming biological function through RNA parts and devices. *Chem Biol*. 2009; 16:298–310. [PubMed: 19318211]
42. Buchholz F, Angrand PO, Stewart AF. Improved properties of FLP recombinase evolved by cycling mutagenesis. *Nat Biotechnol*. 1998; 16:657–662. [PubMed: 9661200]
43. Kilby NJ, Snaith MR, Murray JA. Site-specific recombinases: tools for genome engineering. *Trends Genet*. 1993; 9:413–421. [PubMed: 8122308]
44. Santoro SW, Schultz PG. Directed evolution of the site specificity of Cre recombinase. *Proc Natl Acad Sci U S A*. 2002; 99:4185–4190. [PubMed: 11904359]
45. Groth AC, Calos MP. Phage integrases: biology and applications. *J Mol Biol*. 2004; 335:667–678. [PubMed: 14687564]
46. Kaplan S, Bren A, Dekel E, Alon U. The incoherent feed-forward loop can generate non-monotonic input functions for genes. *Mol Syst Biol*. 2008; 4:203. [PubMed: 18628744]
47. Alper H, Fischer C, Nevoigt E, Stephanopoulos G. Tuning genetic control through promoter engineering. *Proc Natl Acad Sci U S A*. 2005; 102:12678–12683. [PubMed: 16123130]
48. Cox RS 3rd, Surette MG, Elowitz MB. Programming gene expression with combinatorial promoters. *Mol Syst Biol*. 2007; 3:145. [PubMed: 18004278]
49. Hammer K, Mijakovic I, Jensen PR. Synthetic promoter libraries--tuning of gene expression. *Trends Biotechnol*. 2006; 24:53–55. [PubMed: 16406119]
50. Jensen PR, Hammer K. Artificial promoters for metabolic optimization. *Biotechnol Bioeng*. 1998; 58:191–195. [PubMed: 10191389]
51. Murphy KF, Balazsi G, Collins JJ. Combinatorial promoter design for engineering noisy gene expression. *Proc Natl Acad Sci U S A*. 2007; 104:12726–12731. [PubMed: 17652177]
52. Salis HM, Mirsky EA, Voigt CA. Automated design of synthetic ribosome binding sites to control protein expression. *Nat Biotechnol*. 2009; 27:946–950. [PubMed: 19801975]
53. Andersen JB, et al. New unstable variants of green fluorescent protein for studies of transient gene expression in bacteria. *Appl Environ Microbiol*. 1998; 64:2240–2246. [PubMed: 9603842]

54. Nevozhay D, Adams RM, Murphy KF, Josic K, Balazsi G. Negative autoregulation linearizes the dose-response and suppresses the heterogeneity of gene expression. *Proc Natl Acad Sci U S A*. 2009; 106:5123–5128. [PubMed: 19279212]
55. Chandran D, Bergmann FT, Sauro HM. TinkerCell: modular CAD tool for synthetic biology. *J Biol Eng*. 2009; 3:19. [PubMed: 19874625]
56. Kaznessis YN. Computational methods in synthetic biology. *Biotechnol J*. 2009; 4:1392–1405. [PubMed: 19830714]
57. Hasty J, McMillen D, Isaacs F, Collins JJ. Computational studies of gene regulatory networks: in numero molecular biology. *Nat Rev Genet*. 2001; 2:268–279. [PubMed: 11283699]
58. Khalil AS, et al. Single M13 bacteriophage tethering and stretching. *Proc Natl Acad Sci U S A*. 2007; 104:4892–4897. [PubMed: 17360403]
59. Svoboda K, Block SM. Biological applications of optical forces. *Annu Rev Biophys Biomol Struct*. 1994; 23:247–285. [PubMed: 7919782]
60. Bustamante C, Bryant Z, Smith SB. Ten years of tension: single-molecule DNA mechanics. *Nature*. 2003; 421:423–427. [PubMed: 12540915]
61. Khalil AS, et al. Kinesin's cover-neck bundle folds forward to generate force. *Proc Natl Acad Sci U S A*. 2008; 105:19247–19252. [PubMed: 19047639]
62. Neuman KC, Nagy A. Single-molecule force spectroscopy: optical tweezers, magnetic tweezers and atomic force microscopy. *Nat Methods*. 2008; 5:491–505. [PubMed: 18511917]
63. Lee SK, et al. Directed evolution of AraC for improved compatibility of arabinose- and lactose-inducible promoters. *Appl Environ Microbiol*. 2007; 73:5711–5715. [PubMed: 17644634]
64. Gulati S, et al. Opportunities for microfluidic technologies in synthetic biology. *J R Soc Interface*. 2009; 6(Suppl 4):S493–S506. [PubMed: 19474079]
65. Bennett MR, Hasty J. Microfluidic devices for measuring gene network dynamics in single cells. *Nat Rev Genet*. 2009; 10:628–638. [PubMed: 19668248]
66. Simpson ML, Cox CD, Sayler GS. Frequency domain analysis of noise in autoregulated gene circuits. *Proc Natl Acad Sci U S A*. 2003; 100:4551–4556. [PubMed: 12671069]
67. Mettetal JT, Muzzey D, Gomez-Uribe C, van Oudenaarden A. The frequency dependence of osmo-adaptation in *Saccharomyces cerevisiae*. *Science*. 2008; 319:482–484. [PubMed: 18218902]
68. Bennett MR, et al. Metabolic gene regulation in a dynamically changing environment. *Nature*. 2008; 454:1119–1122. [PubMed: 18668041]
69. Malmstrom J, et al. Proteome-wide cellular protein concentrations of the human pathogen *Leptospira interrogans*. *Nature*. 2009; 460:762–765. [PubMed: 19606093]
70. Summerer D, et al. A genetically encoded fluorescent amino acid. *Proc Natl Acad Sci U S A*. 2006; 103:9785–9789. [PubMed: 16785423]
71. Wang J, Xie J, Schultz PG. A genetically encoded fluorescent amino acid. *J Am Chem Soc*. 2006; 128:8738–8739. [PubMed: 16819861]
72. Michalet X, et al. Quantum dots for live cells, in vivo imaging, and diagnostics. *Science*. 2005; 307:538–544. [PubMed: 15681376]
73. Hamad-Schifferli K, Schwartz JJ, Santos AT, Zhang S, Jacobson JM. Remote electronic control of DNA hybridization through inductive coupling to an attached metal nanocrystal antenna. *Nature*. 2002; 415:152–155. [PubMed: 11805829]
74. Boyden ES, Zhang F, Bamberg E, Nagel G, Deisseroth K. Millisecond-timescale, genetically targeted optical control of neural activity. *Nat Neurosci*. 2005; 8:1263–1268. [PubMed: 16116447]
75. Misra N, et al. Bioelectronic silicon nanowire devices using functional membrane proteins. *Proc Natl Acad Sci U S A*. 2009; 106:13780–13784. [PubMed: 19667177]
76. Weber W, Fussenegger M. Engineering of synthetic mammalian gene networks. *Chem Biol*. 2009; 16:287–297. [PubMed: 19318210]
77. Gibson DG, et al. Complete chemical synthesis, assembly, and cloning of a *Mycoplasma genitalium* genome. *Science*. 2008; 319:1215–1220. [PubMed: 18218864]
78. Glass JL, et al. Essential genes of a minimal bacterium. *Proc Natl Acad Sci U S A*. 2006; 103:425–430. [PubMed: 16407165]

79. Lartigue C, et al. Genome transplantation in bacteria: changing one species to another. *Science*. 2007; 317:632–638. [PubMed: 17600181]
80. Lartigue C, et al. Creating Bacterial Strains from Genomes That Have Been Cloned and Engineered in Yeast. *Science*. 2009
81. Carrera J, Rodrigo G, Jaramillo A. Towards the automated engineering of a synthetic genome. *Mol Biosyst*. 2009; 5:733–743. [PubMed: 19562112]
82. Rackham O, Chin JW. A network of orthogonal ribosome x mRNA pairs. *Nat Chem Biol*. 2005; 1:159–166. [PubMed: 16408021]
83. Wang K, Neumann H, Peak-Chew SY, Chin JW. Evolved orthogonal ribosomes enhance the efficiency of synthetic genetic code expansion. *Nat Biotechnol*. 2007; 25:770–777. [PubMed: 17592474]
84. An W, Chin JW. Synthesis of orthogonal transcription-translation networks. *Proc Natl Acad Sci U S A*. 2009; 106:8477–8482. [PubMed: 19443689]
85. Wang Q, Parrish AR, Wang L. Expanding the genetic code for biological studies. *Chem Biol*. 2009; 16:323–336. [PubMed: 19318213]
86. Drinnenberg IA, et al. RNAi in Budding Yeast. *Science*. 2009; 326:544–550. [PubMed: 19745116]
87. Yoon YG, Koob MD. Efficient cloning and engineering of entire mitochondrial genomes in *Escherichia coli* and transfer into transcriptionally active mitochondria. *Nucleic Acids Res*. 2003; 31:1407–1415. [PubMed: 12595548]
88. Austin DW, et al. Gene network shaping of inherent noise spectra. *Nature*. 2006; 439:608–611. [PubMed: 16452980]
89. Mar DJ, Chow CC, Gerstner W, Adams RW, Collins JJ. Noise shaping in populations of coupled model neurons. *Proc Natl Acad Sci U S A*. 1999; 96:10450–10455. [PubMed: 10468629]
90. McGinness KE, Baker TA, Sauer RT. Engineering controllable protein degradation. *Mol Cell*. 2006; 22:701–707. [PubMed: 16762842]
91. Banaszynski LA, Chen LC, Maynard-Smith LA, Ooi AG, Wandless TJ. A rapid, reversible, and tunable method to regulate protein function in living cells using synthetic small molecules. *Cell*. 2006; 126:995–1004. [PubMed: 16959577]
92. Takahashi K, et al. Induction of pluripotent stem cells from adult human fibroblasts by defined factors. *Cell*. 2007; 131:861–872. [PubMed: 18035408]
93. Macarthur BD, Ma'ayan A, Lemischka IR. Systems biology of stem cell fate and cellular reprogramming. *Nat Rev Mol Cell Biol*. 2009
94. Lu T, Ferry M, Weiss R, Hasty J. A molecular noise generator. *Phys Biol*. 2008; 5:36006.
95. Blake WJ, et al. Phenotypic consequences of promoter-mediated transcriptional noise. *Mol Cell*. 2006; 24:853–865. [PubMed: 17189188]
96. Discher DE, Mooney DJ, Zandstra PW. Growth factors, matrices, and forces combine and control stem cells. *Science*. 2009; 324:1673–1677. [PubMed: 19556500]
97. Fernando CT, et al. Molecular circuits for associative learning in single-celled organisms. *J R Soc Interface*. 2009; 6:463–469. [PubMed: 18835803]
98. Fritz G, Buchler NE, Hwa T, Gerland U. Designing sequential transcription logic: a simple genetic circuit for conditional memory. *Syst Synth Biol*. 2007; 1:89–98. [PubMed: 19003438]
99. Tagkopoulos I, Liu YC, Tavazoie S. Predictive behavior within microbial genetic networks. *Science*. 2008; 320:1313–1317. [PubMed: 18467556]
100. Mitchell A, et al. Adaptive prediction of environmental changes by microorganisms. *Nature*. 2009; 460:220–224. [PubMed: 19536156]
101. Lee DK, Itti L, Koch C, Braun J. Attention activates winner-take-all competition among visual filters. *Nat Neurosci*. 1999; 2:375–381. [PubMed: 10204546]
102. Brakmann S, Grzeszik S. An error-prone T7 RNA polymerase mutant generated by directed evolution. *Chembiochem*. 2001; 2:212–219. [PubMed: 11828447]
103. Yeh BJ, Rutigliano RJ, Deb A, Bar-Sagi D, Lim WA. Rewiring cellular morphology pathways with synthetic guanine nucleotide exchange factors. *Nature*. 2007; 447:596–600. [PubMed: 17515921]

104. Dueber JE, Mirsky EA, Lim WA. Engineering synthetic signaling proteins with ultrasensitive input/output control. *Nat Biotechnol.* 2007; 25:660–662. [PubMed: 17515908]
105. Bashor CJ, Helman NC, Yan S, Lim WA. Using engineered scaffold interactions to reshape MAP kinase pathway signaling dynamics. *Science.* 2008; 319:1539–1543. [PubMed: 18339942]
106. Goldberg SD, Derr P, DeGrado WF, Goulian M. Engineered single- and multi-cell chemotaxis pathways in *E. coli*. *Mol Syst Biol.* 2009; 5:283. [PubMed: 19536206]
107. Li L, Lindquist S. Creating a protein-based element of inheritance. *Science.* 2000; 287:661–664. [PubMed: 10650001]
108. Alberti S, Halfmann R, King O, Kapila A, Lindquist S. A systematic survey identifies prions and illuminates sequence features of prionogenic proteins. *Cell.* 2009; 137:146–158. [PubMed: 19345193]
109. Bhalla US, Ram PT, Iyengar R. MAP kinase phosphatase as a locus of flexibility in a mitogen-activated protein kinase signaling network. *Science.* 2002; 297:1018–1023. [PubMed: 12169734]
110. Tsai TY, et al. Robust, tunable biological oscillations from interlinked positive and negative feedback loops. *Science.* 2008; 321:126–129. [PubMed: 18599789]
111. Stavreva DA, et al. Ultradian hormone stimulation induces glucocorticoid receptor-mediated pulses of gene transcription. *Nat Cell Biol.* 2009; 11:1093–1102. [PubMed: 19684579]
112. McMillen D, Kopell N, Hasty J, Collins JJ. Synchronizing genetic relaxation oscillators by intercell signaling. *Proc Natl Acad Sci U S A.* 2002; 99:679–684. [PubMed: 11805323]
113. Garcia-Ojalvo J, Elowitz MB, Strogatz SH. Modeling a synthetic multicellular clock: repressilators coupled by quorum sensing. *Proc Natl Acad Sci U S A.* 2004; 101:10955–10960. [PubMed: 15256602]
114. Sarpeshkar R, O'Halloran M. Scalable hybrid computation with spikes. *Neural Comput.* 2002; 14:2003–2038. [PubMed: 12184840]
115. Molin S, et al. Suicidal genetic elements and their use in biological containment of bacteria. *Annu Rev Microbiol.* 1993; 47:139–166. [PubMed: 8257096]
116. Looger LL, Dwyer MA, Smith JJ, Hellinga HW. Computational design of receptor and sensor proteins with novel functions. *Nature.* 2003; 423:185–190. [PubMed: 12736688]
117. Win MN, Klein JS, Smolke CD. Codeine-binding RNA aptamers and rapid determination of their binding constants using a direct coupling surface plasmon resonance assay. *Nucleic Acids Res.* 2006; 34:5670–5682. [PubMed: 17038331]
118. Skerker JM, et al. Rewiring the specificity of two-component signal transduction systems. *Cell.* 2008; 133:1043–1054. [PubMed: 18555780]
119. Xu J, Lavan DA. Designing artificial cells to harness the biological ion concentration gradient. *Nat Nanotechnol.* 2008; 3:666–670. [PubMed: 18989332]
120. Jogler C, Schuler D. Genomics, genetics, and cell biology of magnetosome formation. *Annu Rev Microbiol.* 2009; 63:501–521. [PubMed: 19575557]
121. Booth IR, Edwards MD, Black S, Schumann U, Miller S. Mechanosensitive channels in bacteria: signs of closure? *Nat Rev Microbiol.* 2007; 5:431–440. [PubMed: 17505523]
122. Falke JJ, Bass RB, Butler SL, Chervitz SA, Danielson MA. The two-component signaling pathway of bacterial chemotaxis: a molecular view of signal transduction by receptors, kinases, and adaptation enzymes. *Annu Rev Cell Dev Biol.* 1997; 13:457–512. [PubMed: 9442881]
123. Gao Z, Tseng CH, Strober BE, Pei Z, Blaser MJ. Substantial alterations of the cutaneous bacterial biota in psoriatic lesions. *PLoS One.* 2008; 3:e2719. [PubMed: 18648509]
124. Grice EA, et al. Topographical and temporal diversity of the human skin microbiome. *Science.* 2009; 324:1190–1192. [PubMed: 19478181]
125. Ley RE, Lozupone CA, Hamady M, Knight R, Gordon JI. Worlds within worlds: evolution of the vertebrate gut microbiota. *Nat Rev Microbiol.* 2008; 6:776–788. [PubMed: 18794915]
126. Turnbaugh PJ, et al. A core gut microbiome in obese and lean twins. *Nature.* 2009; 457:480–484. [PubMed: 19043404]
127. Turnbaugh PJ, et al. An obesity-associated gut microbiome with increased capacity for energy harvest. *Nature.* 2006; 444:1027–1031. [PubMed: 17183312]

128. Steidler L, et al. Treatment of murine colitis by *Lactococcus lactis* secreting interleukin-10. *Science*. 2000; 289:1352–1355. [PubMed: 10958782]
129. Braat H, et al. A phase I trial with transgenic bacteria expressing interleukin-10 in Crohn's disease. *Clin Gastroenterol Hepatol*. 2006; 4:754–759. [PubMed: 16716759]
130. Wei MQ, Mengesha A, Good D, Anne J. Bacterial targeted tumour therapy-dawn of a new era. *Cancer Lett*. 2008; 259:16–27. [PubMed: 18063294]
131. von Maltzahn G, et al. Nanoparticle self-assembly gated by logical proteolytic triggers. *J Am Chem Soc*. 2007; 129:6064–6065. [PubMed: 17447766]
132. Stephanopoulos G. Challenges in engineering microbes for biofuels production. *Science*. 2007; 315:801–804. [PubMed: 17289987]
133. Teule F, et al. A protocol for the production of recombinant spider silk-like proteins for artificial fiber spinning. *Nat Protoc*. 2009; 4:341–355. [PubMed: 19229199]
134. Slotta U, et al. Spider silk and amyloid fibrils: a structural comparison. *Macromol Biosci*. 2007; 7:183–188. [PubMed: 17295405]
135. Rammensee S, Slotta U, Scheibel T, Bausch AR. Assembly mechanism of recombinant spider silk proteins. *Proc Natl Acad Sci U S A*. 2008; 105:6590–6595. [PubMed: 18445655]
136. Widmaier DM, et al. Engineering the *Salmonella* type III secretion system to export spider silk monomers. *Mol Syst Biol*. 2009; 5:309. [PubMed: 19756048]
137. Choi JH, Lee SY. Secretory and extracellular production of recombinant proteins using *Escherichia coli*. *Appl Microbiol Biotechnol*. 2004; 64:625–635. [PubMed: 14966662]
138. Klein-Marcuschamer D, Stephanopoulos G. Assessing the potential of mutational strategies to elicit new phenotypes in industrial strains. *Proc Natl Acad Sci U S A*. 2008; 105:2319–2324. [PubMed: 18252819]
139. Dueber JE, et al. Synthetic protein scaffolds provide modular control over metabolic flux. *Nat Biotechnol*. 2009; 27:753–759. [PubMed: 19648908]

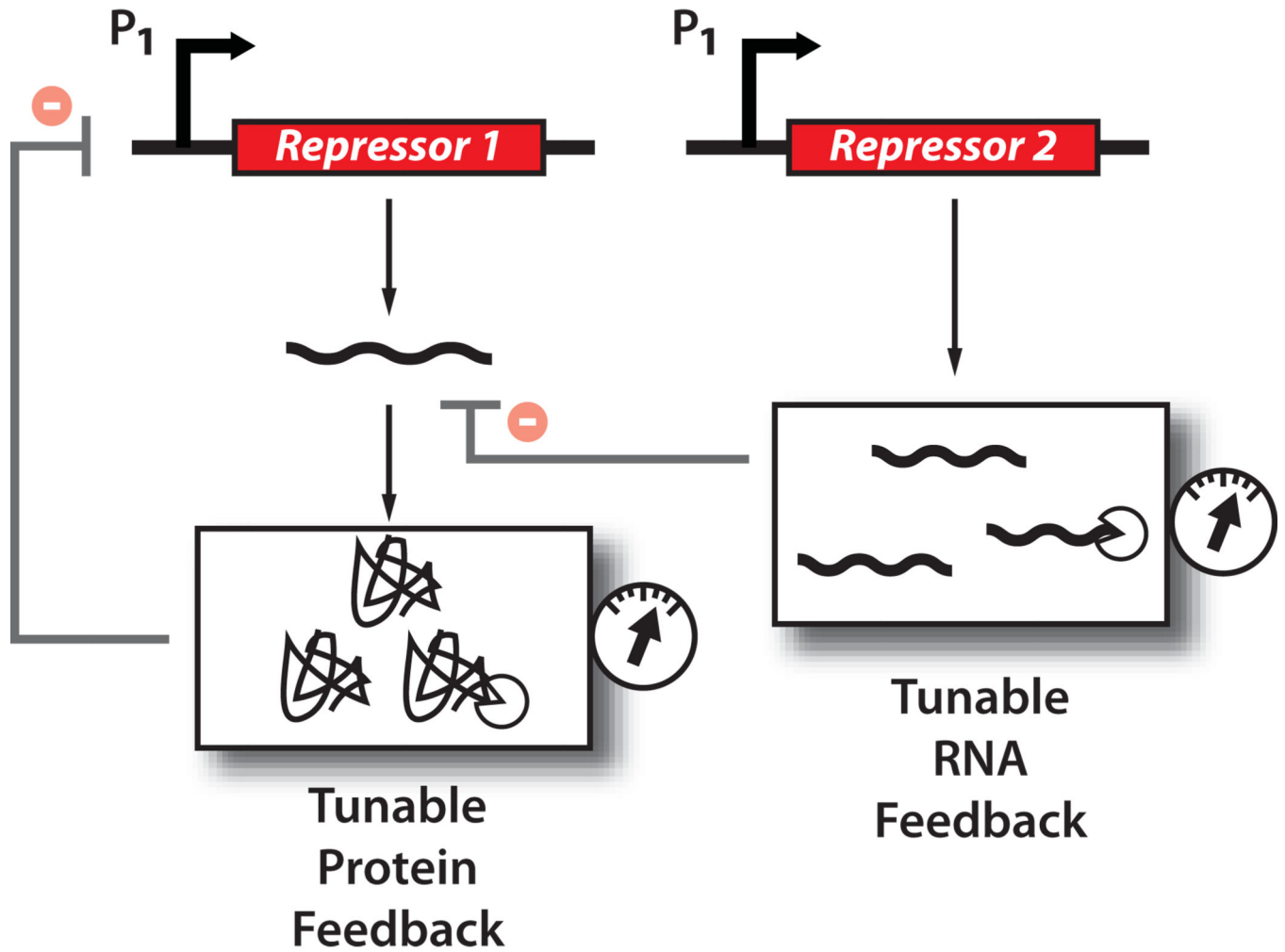

**Figure 1.** Tunable genetic filter. Filter characteristics can be adjusted by tuning the degradation of RNA and protein effectors in negative feedback loops. Examples of RNA effectors include small interfering RNAs, riboregulators, and ribozymes. Examples of protein effectors include transcriptional activators and repressors.

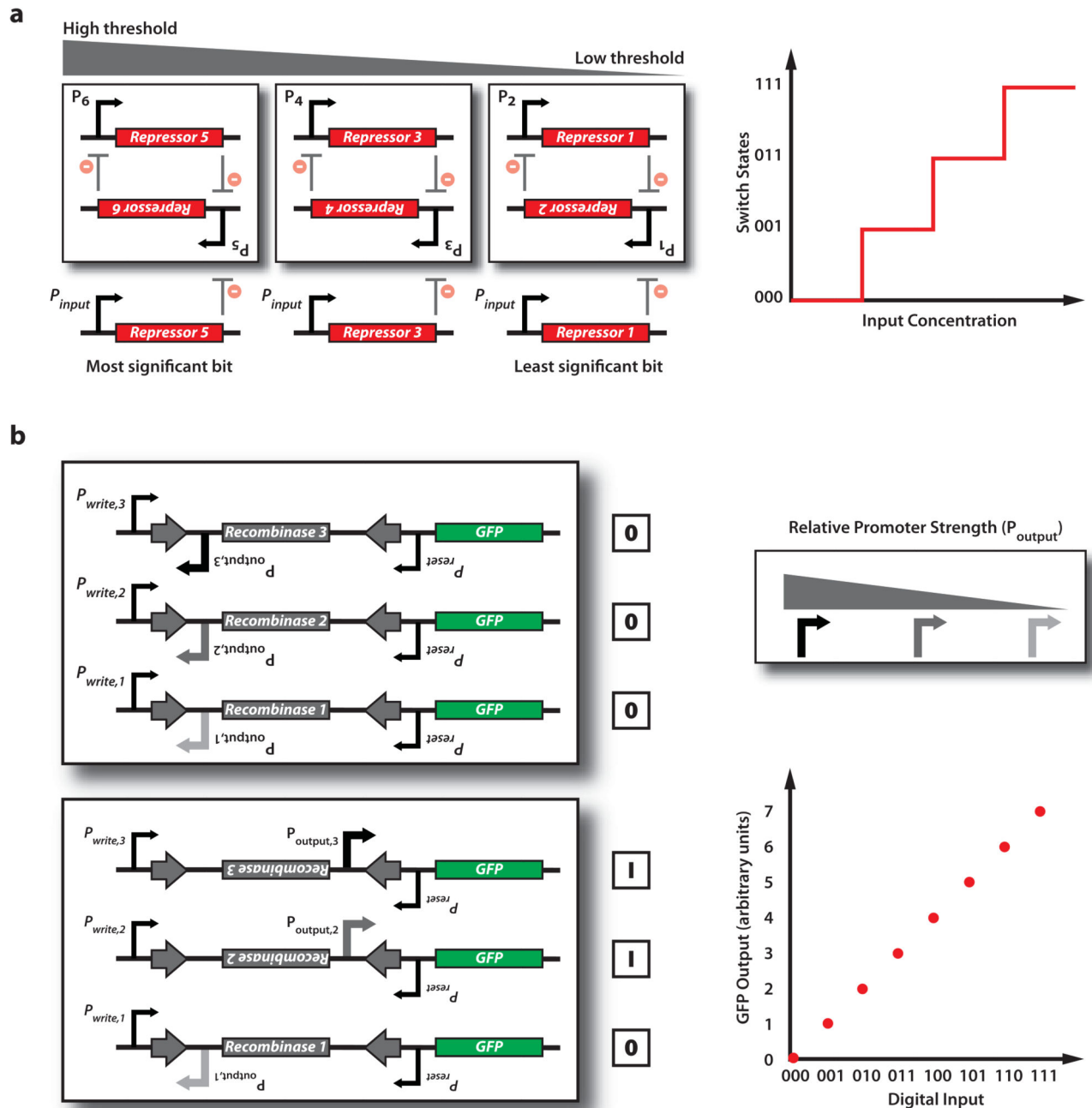
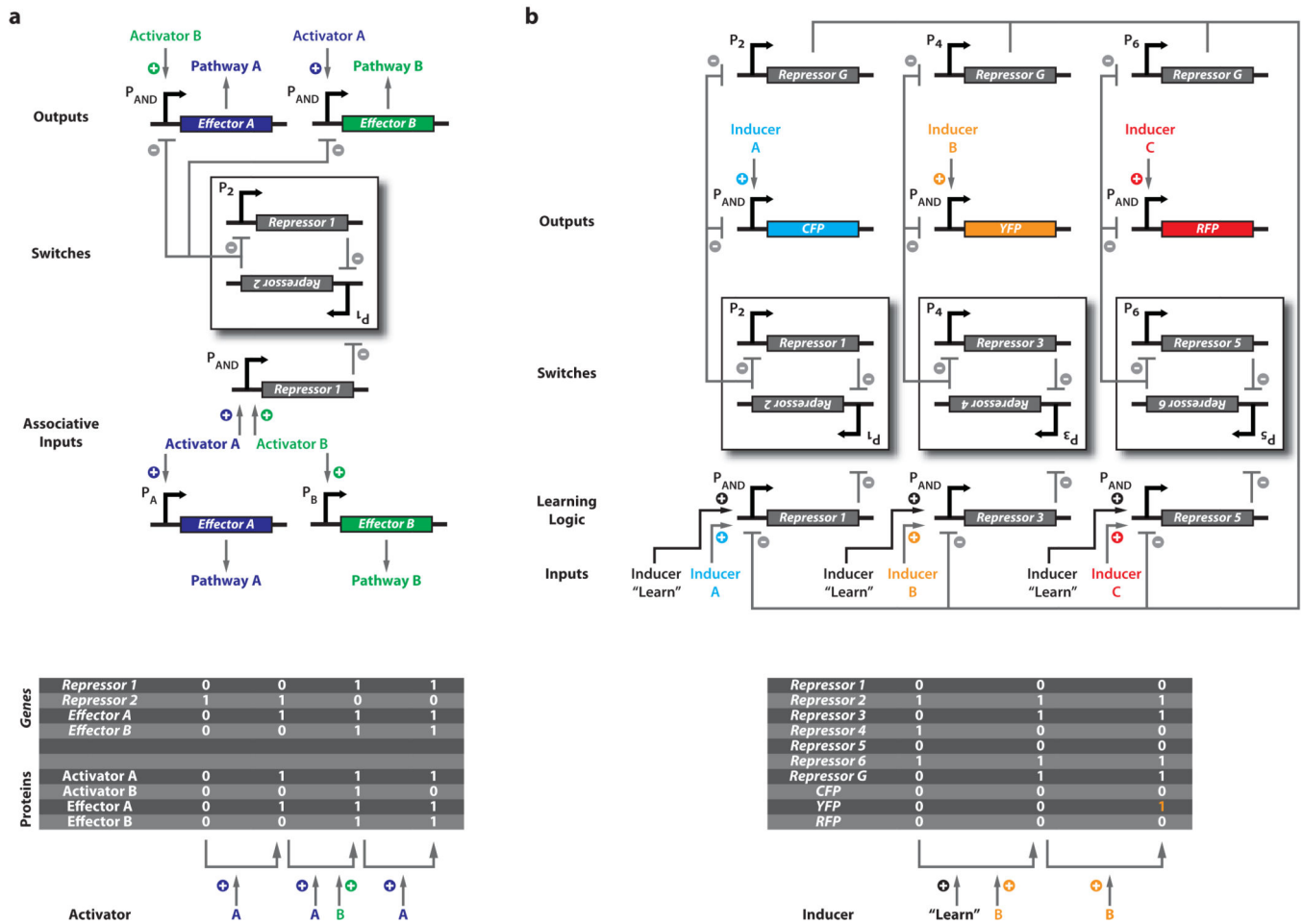

**Figure 2.**

Genetic signal converters. **(a)** Analog-to-digital converter circuit that enables the discretization of analog inputs. The circuit is composed of a bank of toggle switches that have increasing response thresholds so that sequential toggling is achieved as input levels increase. The design could enable different natural or synthetic pathways to be activated depending on distinct input ranges, which may be useful in cell-based biosensing applications. Inputs into promoters and logic operations are shown explicitly except when the promoter name is italicized, which represents an inducible promoter. **(b)** Digital-to-

analog converter circuit that enables the programming of defined promoter activity based on combinatorial inputs. The circuit is composed of a bank of recombinase-based switches, known as single-invertase memory modules (SIMMs)<sup>9</sup>. Each SIMM is composed of an inverted promoter and a recombinase gene located between its cognate recognition sites, indicated by the arrows. Upon the combinatorial addition of inducers that activate specific  $P_{write}$  promoters, different SIMMs will be flipped, enabling promoters of varying strength to drive GFP expression. This allows combinatorial programming of different levels of promoter activity.





**Figure 3.**

Adaptive learning networks. **(a)** Associative memory circuit enables association between two simultaneous inputs (Activator A and Activator B) so that the subsequent presence of only a single input can drive its own pathway and the pathway of the other input. Associations between inputs are recorded by a promoter  $P_{AND}$  that is activated in the presence of Activator A and Activator B to toggle the memory switch. Inputs into promoters and logic operations are shown explicitly except when the promoter name is italicized, which represents an inducible promoter. **(b)** Winner-take-all circuit allows only one input out of many to be recorded. This effect is achieved by a global repressor protein that gates all inputs and prevents them from being recorded if there has already been an input recorded in memory.

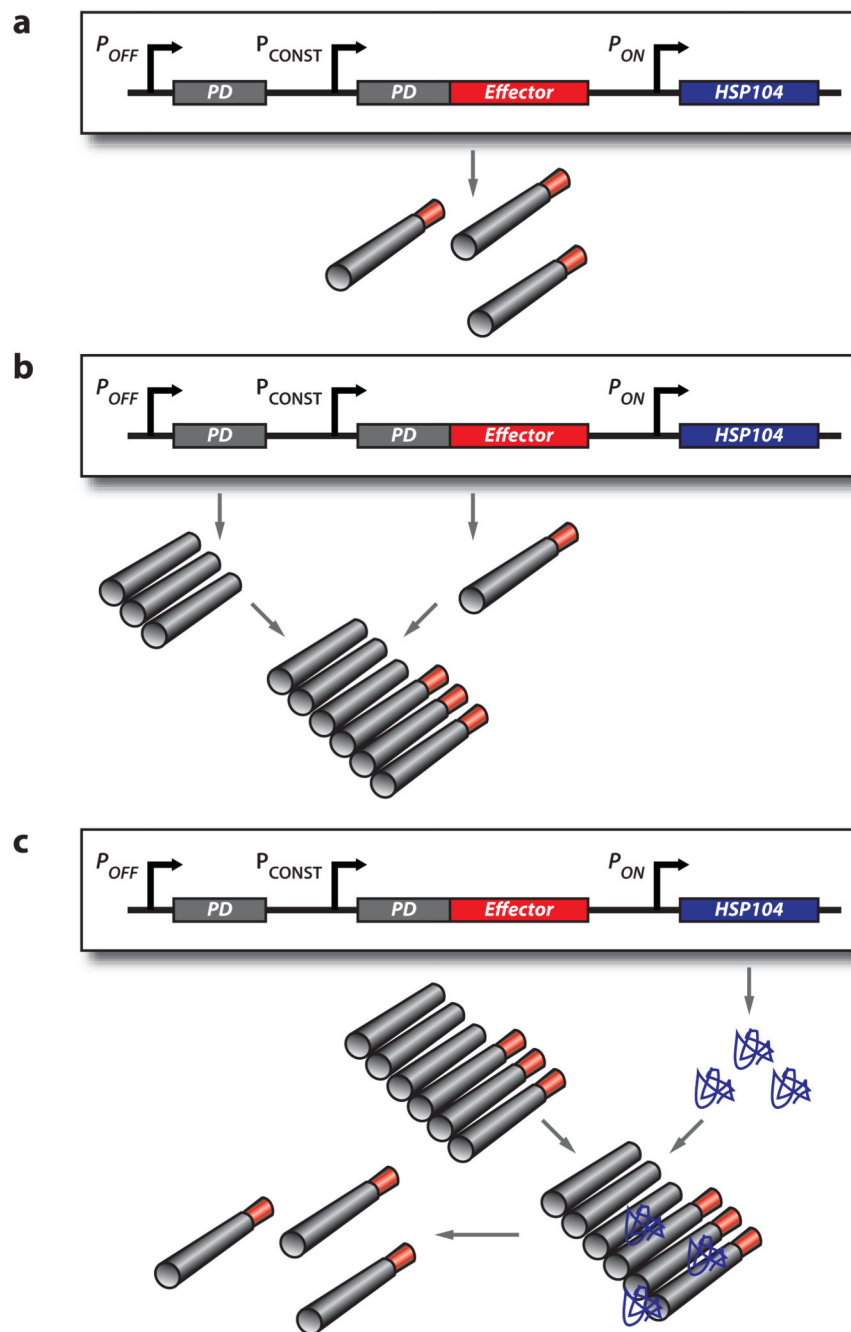

**Figure 4.** Amyloid-based memory. **(a)** Amyloid-based memory can be implemented by fusing a prion-determining region (*PD*) to an effector gene, such as a transcriptional activator. **(b)** Overexpressing the prion-determining region via promoter  $P_{OFF}$  causes aggregation of the fusion protein, rendering the effector inactive. **(c)** Subsequent overexpression of chaperone proteins (*HSP104*), which act to disaggregate amyloids, via promoter  $P_{ON}$  releases the effector from the amyloid state and enables it to fulfill its function. Inputs into promoters

and logic operations are shown explicitly except when the promoter name is italicized, which represents an inducible promoter.

Author Manuscript

Author Manuscript

Author Manuscript

Author Manuscript

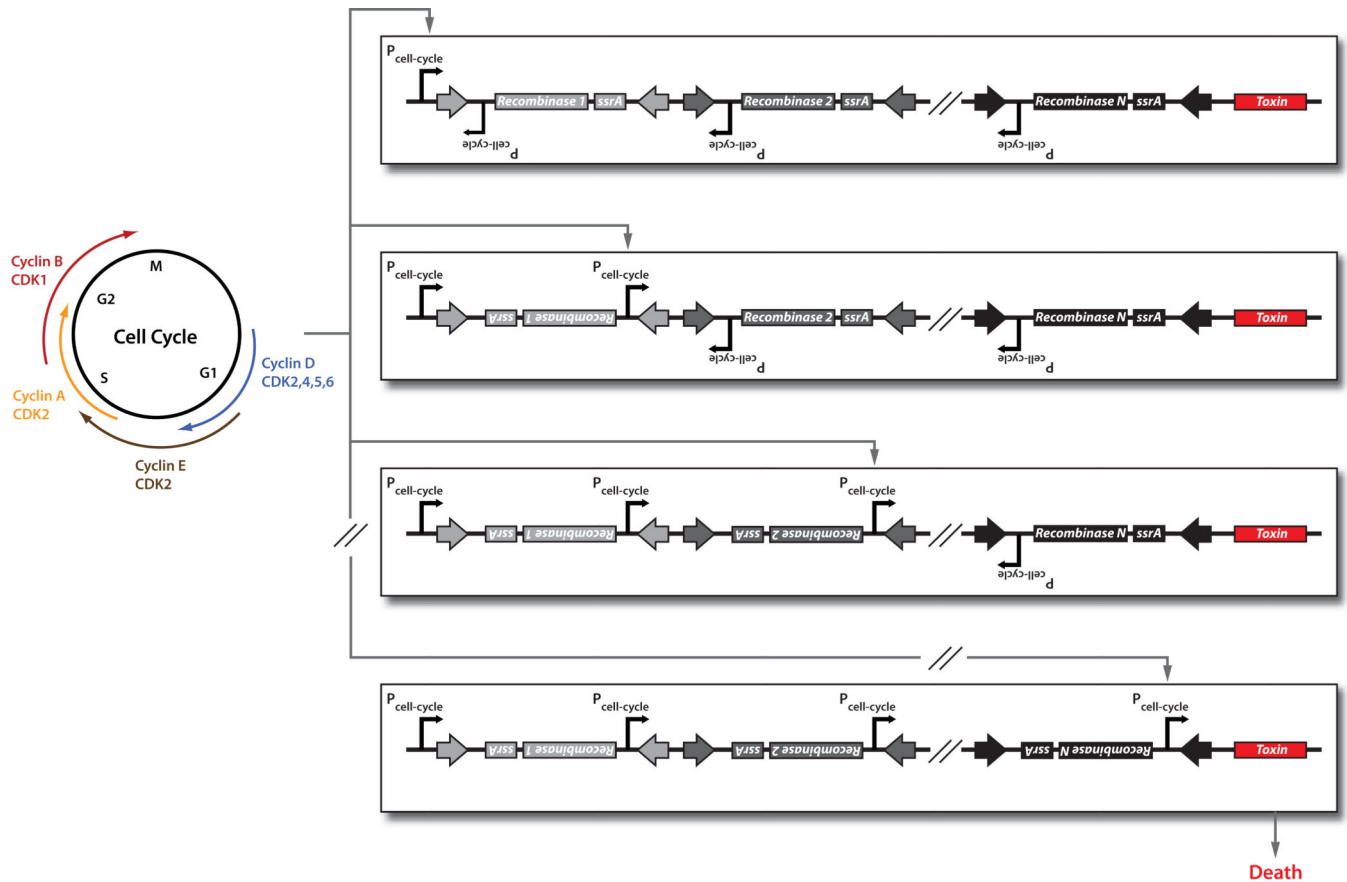

**Figure 5.** Cell-cycle counter for biological containment. Cell-cycle counting is accomplished with a cascade of single recombinase-based memory units (e.g., SIMMs), each of which is driven by a cell cycle-dependent promoter. After  $N$  cell-cycle events are counted, the gene circuit unlocks the expression of a toxic protein triggering cell death.

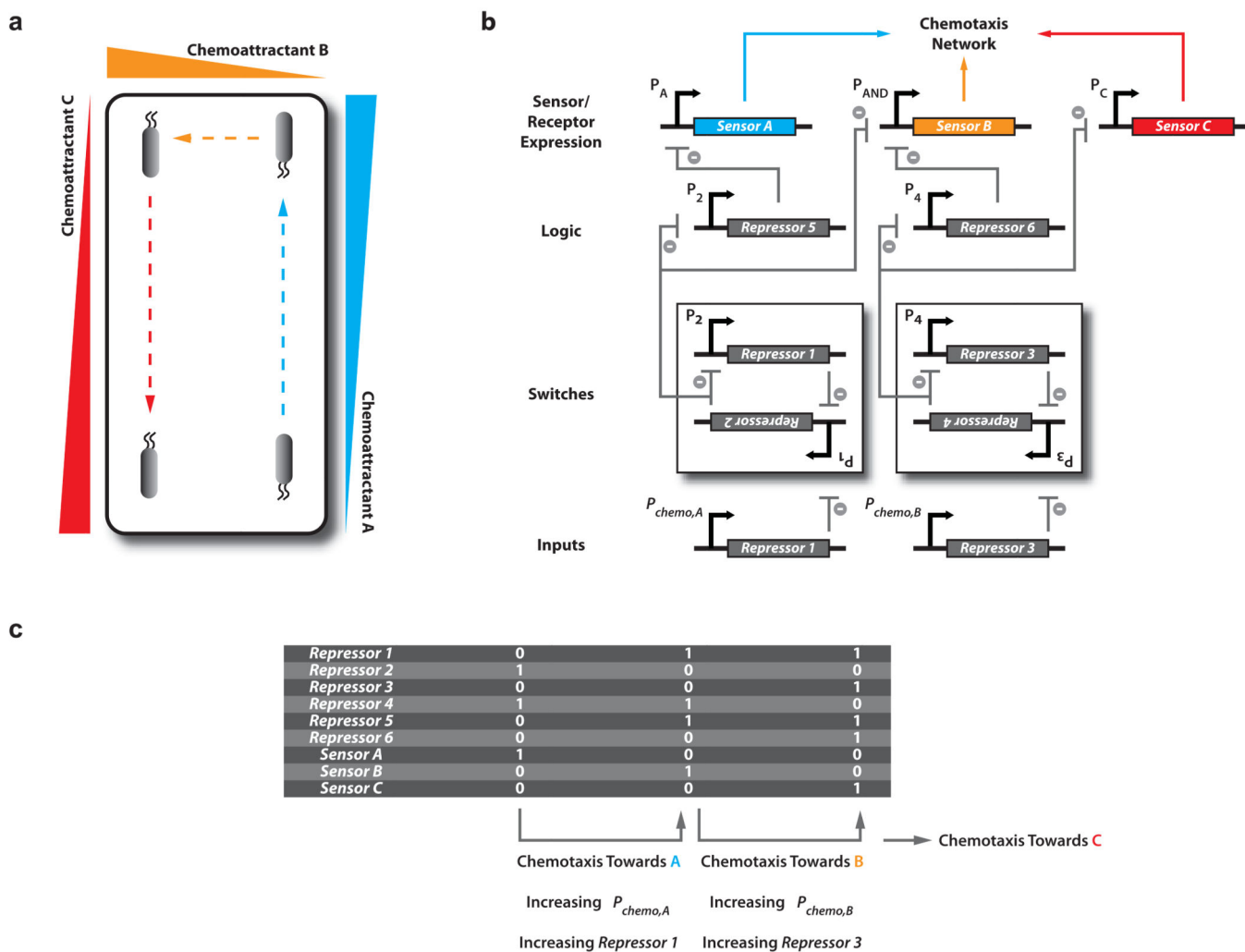

**Figure 6.** Autonomous chemotaxis. **(a)** Chemotactic environment made up of three chemoattractant gradients (A, B, C). **(b)** The synthetic gene network, whereby toggle switches control the sequential expression of three chemotaxis sensor receptors, for autonomously navigating bacteria down three chemoattractant gradients. Inputs into promoters and logic operations are shown explicitly except when the promoter name is italicized, which represents an inducible promoter. **(c)** Boolean on/off values for the network genes illustrate the sequential order of operations.