



## NOTE

Anatomy

# A case report of a rare ramification pattern and distribution area of the mesenteric arteries in a Japanese White rabbit (*Oryctolagus cuniculus*)

Tetsuhito KIGATA<sup>1,2)</sup> and Hideshi SHIBATA<sup>1,2)\*</sup><sup>1)</sup>Laboratory of Veterinary Anatomy, Faculty and Institute of Agriculture, Tokyo University of Agriculture and Technology, Fuchu, Tokyo 183-8509, Japan<sup>2)</sup>Department of Basic Veterinary Science, United Graduate School of Veterinary Sciences, Gifu University, Gifu, Gifu 501-5766, Japan*J. Vet. Med. Sci.*

81(12): 1692–1696, 2019

doi: 10.1292/jvms.19-0352

Received: 28 June 2019

Accepted: 3 October 2019

Advanced Epub:

14 October 2019

**ABSTRACT.** The rabbit intestinal tract is supplied by the cranial and caudal mesenteric arteries. Generally, the cranial mesenteric artery supplies the duodenum, jejunum, ileum, cecum, proximal colon and ascending and transverse distal colon, whereas the caudal mesenteric artery supplies the descending distal colon and rectum. The present study describes an abnormal branching pattern of the cranial and caudal mesenteric arteries in a Japanese White rabbit, where the caudal mesenteric artery but not the cranial mesenteric artery supplied the distal ileum, cecum, proximal colon and ascending and transverse distal colon. Such a rare mesenteric arterial ramification pattern may be explained by anomalies of the remaining anastomotic branches between the primitive mesenteric arteries and regressed their parent arteries during the developmental process.

**KEY WORDS:** arterial anomaly, caudal mesenteric artery, cranial mesenteric artery, rabbit

The rabbit intestinal tract is mainly supplied by the cranial and caudal mesenteric arteries which originate independently from the abdominal aorta [3, 6, 7, 9]. In general, the rabbit cranial mesenteric artery supplies the duodenum, jejunum, ileum, cecum, proximal colon and ascending and transverse distal colon via the caudal pancreaticoduodenal, jejunal, ileal, ileocecolic, right colic and middle colic arteries [3, 6, 7, 9], whereas the caudal mesenteric artery supplies the descending distal colon and rectum via the left colic and cranial rectal arteries [3, 6, 7]. Prior rabbit studies have shown that the distribution area of the cranial and caudal mesenteric arteries remained constant across all cases observed, although frequent individual variations have been reported for the branches of the cranial mesenteric artery [6, 7, 9].

In humans, several authors have reported rare ramification patterns of the cranial (=superior) and caudal (=inferior) mesenteric arteries [1, 4, 5, 10, 16]. For example, Kitamura *et al.* [10] and Yamasaki *et al.* [16] reported cases where the cranial and caudal mesenteric arteries emerged from the abdominal aorta as a common trunk. Dave *et al.* [5] described a duplicated caudal mesenteric artery with one arising from the celiac trunk, while the other originating from the cranial mesenteric artery. Moreover, Abe *et al.* [1] and Covaņteř *et al.* [4] reported cases where the cranial mesenteric artery supplied the small intestine and cecum, while the caudal mesenteric artery supplied most of the colon. The embryological causes of such rare variations have also been discussed in detail in several previous reports [1, 4, 5, 10, 16].

In the rabbit, however, there have not been any previous studies reporting similar anomalies of the cranial and caudal mesenteric arteries. In the present study, we report on an anomaly in a Japanese White rabbit where the caudal mesenteric artery takes over more than half of the distribution area of the cranial mesenteric artery. We subsequently discuss the possible causes of such a rare ramification pattern embryologically.

The Research Ethics Committee for Animal Experimentation of the Tokyo University of Agriculture and Technology (TUAT) approved this study (No. 27-17). A Japanese White rabbit (1.5 years old, 3.2 kg) was obtained from the TUAT Laboratory of Veterinary Pharmacology at the end of a veterinary pharmacology practice class. The experimental procedures were similar to those in our previous study [9]. The rabbit was anesthetized with an intraperitoneal injection of pentobarbital (60 mg/kg) and perfused with saline followed by 10% formalin. Subsequently, 7 ml of latex (Neoprene latex 842A; Showa Denko, Kawasaki, Japan) colored with red acrylic paint (Liquitex; Bonny Colart Co., Ltd., Tokyo, Japan) was injected through a cannula inserted into the thoracic aorta. The arteries and related structures were observed by the naked eye and under a surgical microscope

\*Correspondence to: Shibata, H.: shibata@cc.tuat.ac.jp

©2019 The Japanese Society of Veterinary Science



This is an open-access article distributed under the terms of the Creative Commons Attribution Non-Commercial No Derivatives (by-nc-nd) License. (CC-BY-NC-ND 4.0: <https://creativecommons.org/licenses/by-nc-nd/4.0/>)

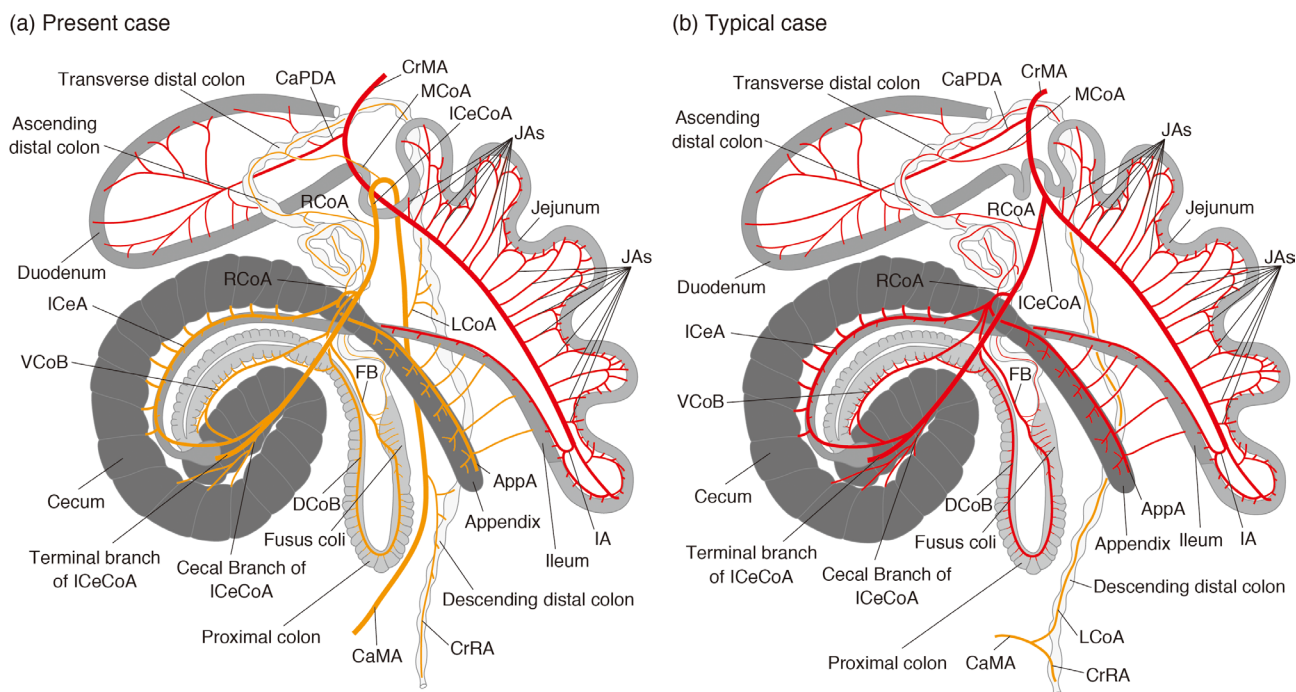

**Fig. 1.** Schematic drawings of the ramification patterns of the cranial (depicted in red) and caudal (depicted in orange) mesenteric arteries in the present (a) and typical (b) cases from a ventral view. The illustrations were drawn based on Fig. 1 of Kigata *et al.* [9] with permission. AppA, appendicular artery; CaMA, caudal mesenteric artery; CaPDA, caudal pancreaticoduodenal artery; CrMA, cranial mesenteric artery; CrRA, cranial rectal artery; DCoB, dorsal colic branch; FB, fusus branch; IA, ileal artery; ICeA, ileocecal artery; ICeCoA, ileocecocolic artery; JA, jejunal artery; LCoA, left colic artery; MCoA, middle colic artery; RCoA, right colic artery; and VCoB, ventral colic branch.

(L-0950SDP; Inami & Co., Ltd., Tokyo, Japan). Photographs were taken with a digital camera (Nikon D5500; Nikon Co., Tokyo, Japan), and their contrast and resolution were adjusted with Adobe Photoshop (Adobe Systems, San Jose, CA, U.S.A.). Schematic drawings were prepared with Adobe Illustrator (Adobe Systems). In the present study, the nomenclature used for the arteries was the same as that used in our previous study [9], while the colonic segments were named in accordance with the findings reported by Snipes *et al.* [13]. The ascending, transverse and descending distal colons were named relative to the position of the root of the cranial mesenteric artery. For ease of comparison to the arteries in the rabbit, “cranial” and “caudal” were used for arteries in humans instead of “superior” and “inferior”.

Figures 1 and 2, respectively, show the schematic drawings and simplified diagrams of the branching pattern of the cranial and caudal mesenteric arteries in the present rare (Figs. 1a and 2a) and a typical (Figs. 1b and 2b) cases. In the rare case reported here, the cranial mesenteric artery emerged from the abdominal aorta, ran to the right, and then turned to the left and crossed the caudal side of the caudal mesenteric artery. Subsequently, it ran caudolaterally to distribute to the duodenum, jejunum and proximal ileum via the caudal pancreaticoduodenal, jejunal and ileal arteries (Figs. 1a, 2a, 3 and 4).

The caudal mesenteric artery arose from the abdominal aorta and ran cranially to supply the rectum, descending distal colon and transverse distal colon via the cranial rectal, left colic and middle colic arteries, respectively (Figs. 1a and 5). The caudal mesenteric artery then turned caudally and continued as the ileocecocolic artery (Figs. 1a and 3) which supplied the appendix via the appendicular artery, cecum and distal ileum via the ileocecal artery, the first and second segments of the proximal colon via the ventral and dorsal colic branches, the fusus coli via the fusus branch and ascending distal colon via two right colic arteries (Figs. 1a and 5). After giving off these branches, the ileocecocolic artery supplied the cecum and ileocecocolic junction via the cecal and terminal branches of the ileocecocolic artery (Figs. 1a and 5).

The common branching pattern of the mesenteric arteries in the rabbit is that the cranial mesenteric artery gives rise to the caudal pancreaticoduodenal, jejunal, ileal, ileocecocolic, middle colic and right colic arteries, whereas the caudal mesenteric artery branches off the left colic and cranial rectal arteries [3, 6, 7, 9]. In the rare case reported here, however, the cranial mesenteric artery only gave rise to the caudal pancreaticoduodenal, jejunal and ileal arteries, whereas the caudal mesenteric artery gave origin to the ileocecocolic, middle colic, right colic, left colic and cranial rectal arteries. Although prior rabbit studies have not reported this untypical branching pattern [2, 6, 7, 9], Abe *et al.* [1] and Covantev *et al.* [4] reported a similar case in humans, in which the cranial mesenteric artery supplied the proximal small portion of the ascending colon and cecum [1], or cecum only [4] via the ileocecal artery. Furthermore, they also found that the caudal mesenteric artery supplied most of the colon via the right colic, cranial left colic and caudal left colic arteries [1], or via the right colic, middle colic, accessory middle colic, left colic and accessory left colic arteries [4]. These cases are similar to our present case, except for the ileocecocolic (=their ileocecal) artery that

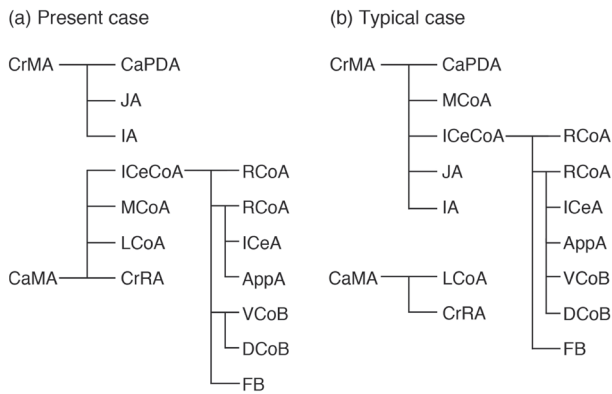

**Fig. 2.** Diagrams showing the branching pattern of the cranial and caudal mesenteric arteries in the present rare (a) and a typical (b) case. In the present rare case, the ramification pattern of the ileocecolic artery was different from that of the typical case. For detailed description of the variation in the ramification pattern of the ileocecolic artery, see Kigata *et al.* [9]. AppA, appendicular artery; CaMA, caudal mesenteric artery; CaPDA, caudal pancreaticoduodenal artery; CrMA, cranial mesenteric artery; CrRA, cranial rectal artery; DCoB, dorsal colic branch; FB, fusus branch; IA, ileal artery; ICeA, ileocecal artery; ICeCoA, ileocecolic artery; JA, jejunal artery; LCoA, left colic artery; MCoA, middle colic artery; RCoA, right colic artery; and VCoB, ventral colic branch.

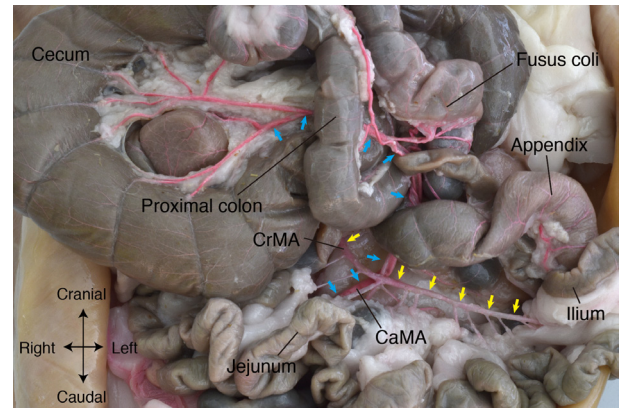

**Fig. 3.** Photograph of the crossing point of the cranial (yellow arrows) and caudal (blue arrows) mesenteric arteries from a ventral view. The cecum and proximal colon are reflected to the right side. CaMA, caudal mesenteric artery; and CrMA, cranial mesenteric artery.

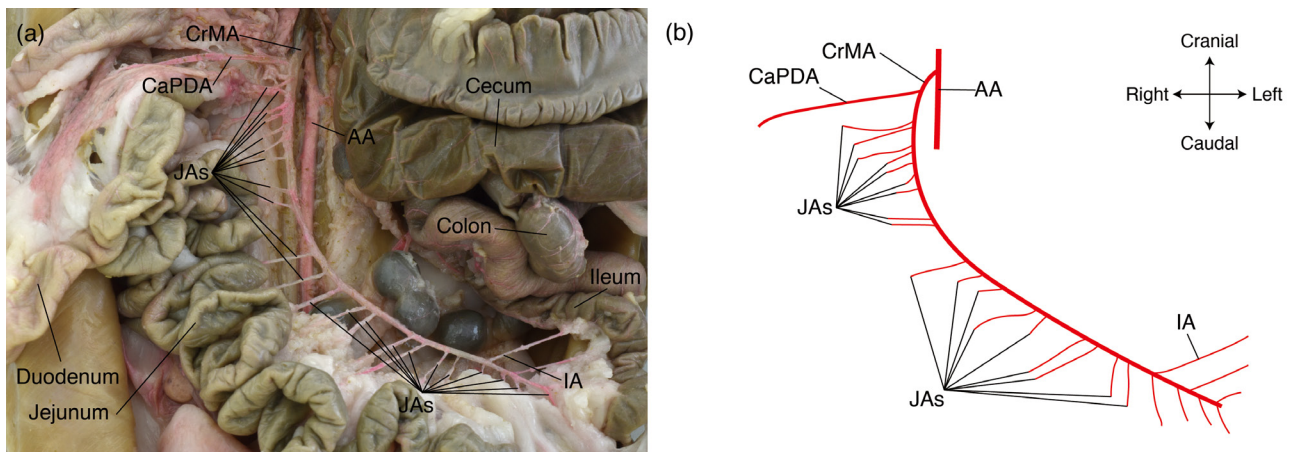

**Fig. 4.** (a) Photograph of the branching pattern of the cranial mesenteric, caudal pancreaticoduodenal, jejunal and ileal arteries from a ventral view. The cecum, distal portion of the ileum and colon are reflected cranially. (b) Schematic drawing of (a). AA, abdominal aorta; CaPDA, caudal pancreaticoduodenal artery; CrMA, cranial mesenteric artery; IA, ileal artery; and JA, jejunal artery.

did not emerge from the cranial mesenteric but rather from the caudal mesenteric artery.

The occurrence of the present anomaly in the mesenteric arteries may be explained by the developmental processes of these arteries. In the initial stage of the arteriogenesis, the primitive mesenteric arteries connect with each other via anastomotic branches, most of which later regress during the course of development [8, 11, 14]. However, some parts of these anastomotic branches may not always regress and thus may cause a variation in the branching pattern of the cranial and caudal mesenteric arteries and their branches in humans [1, 5, 10, 16]. One of the embryological remnants of the anastomosis is referred to as the intermesenteric arteries, which have been observed between the middle and left colic arteries, or between the cranial mesenteric and left colic arteries, or between the cranial and caudal mesenteric arteries [12, 15]. Abe *et al.* [1] and Yamasaki *et al.* [16] reported that the intermesenteric arteries may give origin to the colic arteries and cause an anatomical variation in the branching pattern of the colic arteries depending on the regression pattern of the intermesenteric arteries and their parent arteries. In the present case (Fig. 6), it is assumed that there were two intermesenteric arteries, which anastomosed between the ileocecolic and middle colic arteries (blue line in Fig. 6), and between the middle colic and left colic arteries (green line in Fig. 6). Due to these residual anastomoses, the

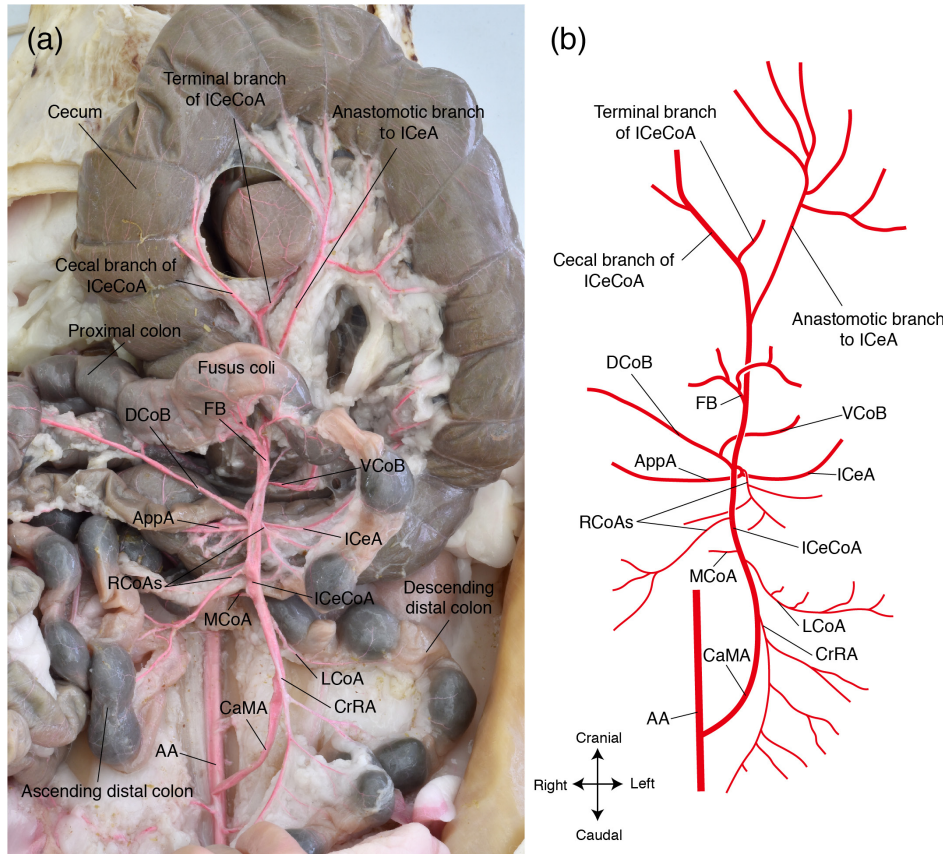

**Fig. 5.** (a) Photograph showing the ramification pattern of the caudal mesenteric artery from a ventral view. The cecum, distal portion of the ileum and proximal colon are reflected cranially, and the jejunum and proximal portion of the ileum are pulled out to the right side. (b) Schematic drawing of (a). AA, abdominal aorta; AppA, appendicular artery; CaMA, caudal mesenteric artery; CrRA, cranial rectal artery; DCoB, dorsal colic branch; FB, fusus branch; ICeA, ileocecal artery; ICeCoA, ileoceocolic artery; LCoA, left colic artery; MCoA, middle colic artery; RCoA, right colic artery; and VCoB, ventral colic branch.

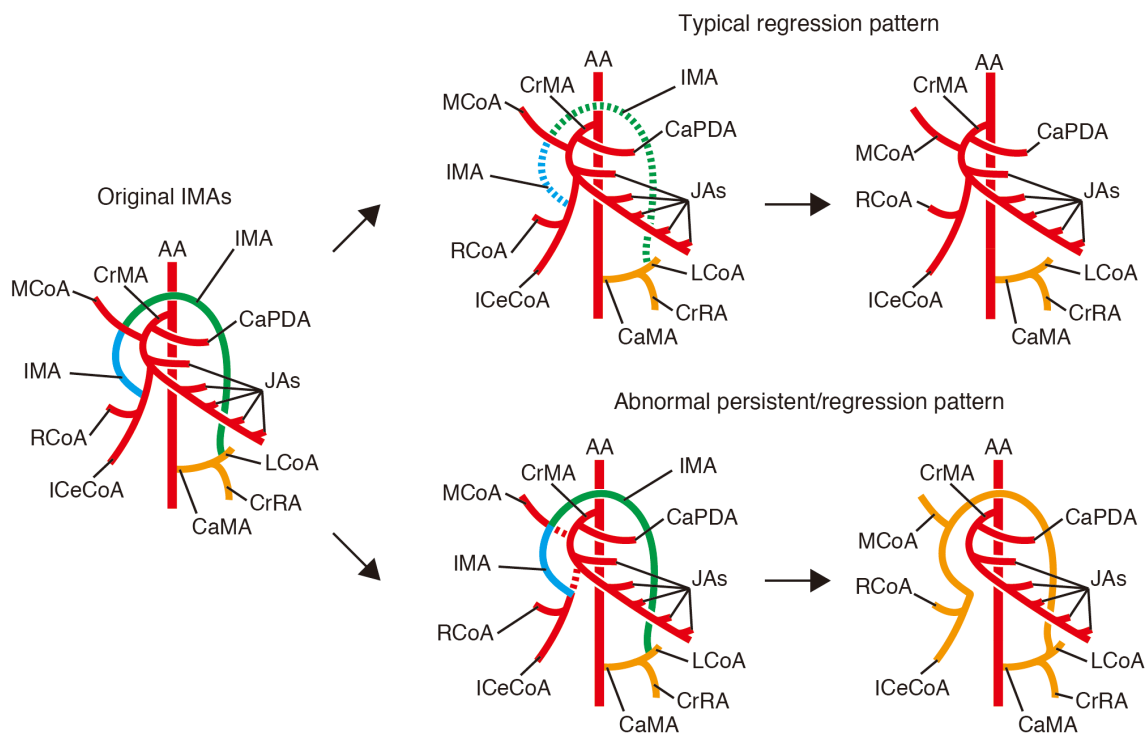

**Fig. 6.** Schematic drawing showing presumable developmental causes of the present arterial anomaly. Intermesenteric arteries are depicted in green or blue, the cranial mesenteric artery is depicted in red, and the caudal mesenteric artery is depicted in orange. Dotted lines indicate the arteries which regress during the development. AA, abdominal aorta; CaMA, caudal mesenteric artery; CaPDA, caudal pancreaticoduodenal artery; CrMA, cranial mesenteric artery; CrRA, cranial rectal artery; ICeCoA, ileoceocolic artery; IMA, intermesenteric artery; JA, jejunal artery; LCoA, left colic artery; MCoA, middle colic artery; and RCoA, right colic artery.

caudal mesenteric artery may have taken over the origins of the ileoceocolic and middle colic arteries from the cranial mesenteric artery, thereby leading to the regression of the roots of these arteries from the cranial mesenteric artery. As a result, the cranial mesenteric artery only gave rise to the caudal pancreaticoduodenal, jejunal and ileal arteries, whereas the caudal mesenteric artery gave rise to the ileoceocolic, right colic, middle colic, left colic and cranial rectal arteries.

In conclusion, the present rare case of abnormal cranial and caudal mesenteric arteries observed in this rabbit can potentially be explained by anomalies of the remaining anastomotic branches between the primitive mesenteric arteries that were present during the developmental period.

**ACKNOWLEDGMENT.** The present study was supported by the Program for the Development of Young Researchers from the Discretionary Budget of the Dean of the United Graduate School of Veterinary Sciences, Gifu University (H30-3).

## REFERENCES

1. Abe, T., Ujiie, A., Taguchi, Y., Satoh, S., Shibuya, T., Jun, Y., Isogai, S. and Satoh, Y. I. 2018. Anomalous inferior mesenteric artery supplying the ascending, transverse, descending, and sigmoid colons. *Anat. Sci. Int.* **93**: 144–148. [[Medline](#)] [[CrossRef](#)]
2. Arredondo, J., Saucedo, R., Recillas, S., Fajardo, V., Castelán, O., González-Ronquillo, M. and Hernández, W. 2017. Visceral branches of the abdominal aorta in the New Zealand rabbit: ten different patterns. *Int. J. Morphol.* **35**: 306–309. [[CrossRef](#)]
3. Barone, R. 2011. Artères. pp. 103–448. *In: Anatomie Comparée des Mammifères Domestiques, Tome 5: angiologie*, 2nd ed., Editions Vigot, Paris.
4. Covaņev, S., Mazuruc, N. and Belic, O. 2017. An unusual case of colon vascularization by the inferior mesenteric artery. *J. Vasc. Bras.* **16**: 52–55. [[Medline](#)] [[CrossRef](#)]
5. Dave, A., Aryaie, B., Gluckman, S. and Dalal, R. 2018. The inferior mesenteric artery arising as a persistence of the ventral longitudinal anastomosis: a rare anatomical variation. *Eur. J. Anat.* **22**: 415–418.
6. Estruc, T. M., Nascimento, R. M., Siston, N. M., Mencialha, R. and Abidu-Figueiredo, M. 2015. Origin and main branches of the cranial and caudal mesenteric arteries in the New Zealand rabbit. *J. Morphol. Sci.* **32**: 143–148. [[CrossRef](#)]
7. Flešárová, S. and Maženský, D. 2018. Macroscopic study of celiac, cranial mesenteric and caudal mesenteric arteries in the European hare. *Folia Vet.* **62**: 5–10. [[CrossRef](#)]
8. Grosser, O., Lewis, F. T. and McMurrich, J. P. 1912. The development of the digestive tract and of the organs of respiration. pp. 291–497. *In: Manual of Human Embryology, Vol. 2* (Keibel, F. and Mall, F. P. eds.), Lippincott, Philadelphia.
9. Kigata, T., Ikegami, R. and Shibata, H. 2018. Macroscopic anatomical study of the distribution of the cranial mesenteric artery to the intestine in the rabbit. *Anat. Sci. Int.* **93**: 291–298. [[Medline](#)] [[CrossRef](#)]
10. Kitamura, S., Nishiguchi, T., Sakai, A. and Kumamoto, K. 1987. Rare case of the inferior mesenteric artery arising from the superior mesenteric artery. *Anat. Rec.* **217**: 99–102. [[Medline](#)] [[CrossRef](#)]
11. Minot, C. S., Evans, H. M., Tandler, J. and Sabin, F. R. 1912. The development of the blood, the vascular system, and the spleen. pp. 498–751. *In: Manual of Human Embryology, Vol. 2* (Keibel, F. and Mall, F. P. eds.), Lippincott, Philadelphia.
12. Pikkieff, H. 1931. Blood supply to the large intestine. *Zschr. Anat. Entw.* **96**: 658–679 (in German). [[CrossRef](#)]
13. Snipes, R. L., Clauss, W., Weber, A. and Hörnicke, H. 1982. Structural and functional differences in various divisions of the rabbit colon. *Cell Tissue Res.* **225**: 331–346. [[Medline](#)] [[CrossRef](#)]
14. Tandler, J. 1903. Ontogeny of human intestinal arteries. *Anat. Hefte* **23**: 188–210 (in German). [[CrossRef](#)]
15. Williams, G. H. and Klop, E. J. Jr. 1957. Intermesenteric arterial communications. *Med. Bull. (Ann Arbor)* **23**: 53–57. [[Medline](#)]
16. Yamasaki, M., Nakao, T., Ishizawa, A. and Ogawa, R. 1990. A rare case of the inferior mesenteric artery and some colic arteries in man. *Anat. Anz.* **171**: 343–349. [[Medline](#)]