



The influence of prior intention on joint action: an fNIRS-based hyperscanning study

Yixin Chen,¹ Qihan Zhang,¹ Sheng Yuan,¹ Bingjie Zhao,¹ Peng Zhang,¹ and Xuejun Bai^{1,2,3}

¹Psychology, Tianjin Normal University, Tianjin 300354, China, ²Academy of Psychology and Behavior, Tianjin Normal University, Tianjin 300354, China, and ³Center of Collaborative Innovation for Assessment and Promotion of Mental Health, Tianjin Normal University, Tianjin 300354, China

Correspondence should be addressed to Xuejun Bai, Academy of Psychology and Behavior, Tianjin Normal University, No. 393 Binshuixi Road, Xiqing District, Tianjin 300354, P.R. China. E-mail: bxuejun@126.com

Abstract

Motor performances of the same action are affected by prior intentions to move unintentionally, cooperatively or competitively. Here, a back-and-forth movement task combined with a motion capture system and functional near-infrared spectroscopy (fNIRS)-based hyperscanning technology was utilized to record both the behavioral and neural data of 18 dyads of participants acting in pairs [joint conditions: no-intention, cooperative (Coop) and competitive (Comp)] or alone (single conditions: self-paced and fast-speed). The results revealed that Coop or Comp intentions in the joint conditions significantly sped up motor performance compared with similar single conditions, e.g. shorter movement times (MTs) in the Coop/Comp condition than the self-paced/fast-speed condition. Hemodynamic response analysis demonstrated that stronger activities for all joint conditions than the single conditions in the premotor and the supplementary motor cortex (Brodmann area 6) were independent of variations of MTs, indicating that they might reflect more complex aspects of action planning rather than simple execution-based processes. The comparisons of joint conditions across distinct prior intentions before acting yielded significant results for both behavioral and neural measures, with the highest activation of the temporo-parietal junction (TPJ) and the shortest MTs in the Comp condition considered to be implications for the top-down influence of prior intentions on joint performance.

Key words: prior intention; joint action; premotor and supplementary motor cortex; temporo-parietal junction; hyperscanning

Introduction

Actions are normally performed with prior intentions, and prior intentions are defined as plans or tendencies that guide actions in the environment (Ondobaka *et al.*, 2012). Indeed, the same action can be performed differently depending on whether the action is aimed at cooperation/competition or

performed alone/with others. For example, the movement kinematic analysis of a reaching-to-grasp movement that was separately performed in a cooperative (Coop) task and a competitive (Comp) task demonstrated an effect of prior intention, such as the longer movement times (MTs) and longer deceleration times that were found in the Coop condition than in the Comp

Received: 23 November 2019; Revised: 17 October 2020; Accepted: 20 November 2020

© The Author(s) 2020. Published by Oxford University Press.

This is an Open Access article distributed under the terms of the Creative Commons Attribution Non-Commercial License (<http://creativecommons.org/licenses/by-nc/4.0/>), which permits non-commercial re-use, distribution, and reproduction in any medium, provided the original work is properly cited. For commercial re-use, please contact journals.permissions@oup.com

condition (Georgiou et al., 2007). One's judgment as to the estimated weight of the box was reported to be heavier when the intention was to lift the box alone than when the intention was to lift the box with a coactor (Doerffeld et al., 2012). In daily life, two people may perform the same task while having distinct intentions in regard to this task. To illustrate, picture two people matched in strength walking side by side along a road. They might synchronize their steps deliberately or unconsciously, or they may compete with each other to determine who had a longer walking stride. This scenario raises the following question: what are the behavioral and neural patterns of these distinct intentions influencing the same motor behavior of walking together?

Joint action refers to 'any form of social interaction whereby two or more individuals coordinate their actions in space and time to bring about a change in the environment' (Sebanz et al., 2006). An individual conducting an action with the intent to interact with somebody (joint action), rather than to perform the action individually (single action), can cause differences in the processes of action planning and monitoring. Former studies in the field of joint action have yielded considerable evidence illustrating the difference between single tasks and joint tasks (Vesper et al., 2011, 2013; Pezzulo et al., 2017). These studies converged on the role of the mirror neuron system (MNS) as an automatic emulator in joint action, facilitating joint performance based on the use of one's own motor repertoire to simulate another actor's actions in real time (Wilson and Knoblich, 2005), hence adapting our action plans to the actions of the nearby coactor (Kokal et al., 2009). Findings from a neuroimaging study revealed that the joint performance of a visual-motor balancing task engaged neural substrates in the MNS [e.g. inferior frontal gyrus (IFG), inferior parietal lobe and premotor cortex] and brain areas belonging to the mentalizing system [i.e. temporo-parietal junction (TPJ)] (Newman-Norlund et al., 2008).

In contrast with many studies that have supported the role of the MNS in the simulation of the movements of others through comparisons of joint and single actions, information concerning the contribution of the TPJ to the ability to perform differently intended actions is relatively rare and controversial. Specifically, the right temporo-parietal junction (rTPJ) has been shown to not only be more activated in the joint condition than in the single condition, but the activation pattern of this area is also regulated by self-other-related processes (Decety et al., 2004; Abe et al., 2019). However, despite the needs to consider self-other processes in different types of joint action (Milward and Sebanz, 2016), opinions of those studies differ widely on this issue. For example, some researchers have proposed that the rTPJ is related to a self-other merging process, and a greater degree of cooperation—measured as the degree of influence from the coactor in a Coop task—has been discovered via calculation to relate to the enhanced activation in the rTPJ (Abe et al., 2019). In other cases, however, the stronger rTPJ activities were reported in contexts with a higher emphasis on self-other distinction (i.e. competition) than in contexts with a greater emphasis on self-other merging (i.e. cooperation; Decety et al., 2004). Despite disagreements as to whether the variations of rTPJ activities reflect self-other merging or distinction, it is possible that activation patterns of the rTPJ differ in joint conditions with Coop or Comp intention. Additionally, the inter-brain synchronization (IBS) of actors-coactors may also vary between joint conditions due to action coordination differences in those conditions based on the viewpoint that interpersonal action coordination is related to both inter-brain and intra-brain activities of frontal and parietal areas (Sänger et al., 2012).

The neural mechanisms of joint action have been studied primarily through comparisons between single action and joint action to reveal the substrate of action coordination between the actor and the coactor, yet few studies have considered the top-down regulation of prior intention on self-other processes. To investigate this phenomenon, a hyperscanning technique applied with functional near-infrared spectroscopy (fNIRS) was utilized in our present study to record the inter-brain and intra-brain activities of participants performing a joint movement task, which is a task that was previously established by Schmitz et al., (2017). Hyperscanning is a technique that enables the simultaneous collection of hemodynamic activities of multiple subjects (Babiloni and Astolfi, 2014), allowing the investigation of two brains interacting in real time (Schilbach et al., 2013). In addition, the fNIRS equipment with a high motion tolerance is suitable for the present study due to the motor characteristics of the movement task (Egetemeir et al., 2011; Nozawa et al., 2016).

The present study consisted of the following two aims. First, we were interested in differences between the prior intent to act with somebody and the prior intent to act alone (i.e. joint vs single action). Since it has previously been demonstrated that acting together vs acting alone yields distinctions in action planning (Tsai et al., 2006; Vesper et al., 2010), we presumed that an increase of planning-related neural changes and adjustment of action performance would emerge in different types of joint conditions. Specifically, the premotor and the supplementary motor cortex, which have proven to be important neural substrates for action planning (Shima et al., 1996; Abdalmalak et al., 2019), was hypothesized to have stronger activities in the joint conditions than in the single conditions. Second, we aimed to elucidate the function of the rTPJ during the joint conditions with different intentions. If the rTPJ reflects the self-other distinction, then the activation level of the rTPJ in the Coop condition would be the weakest among the joint conditions, due to self-other merging resulting from cooperation (Ruissen and de Bruijn, 2016). Due to the relation between interpersonal motor coordination inter-brain activities of frontal and parietal areas (Sänger et al., 2012), different intentions of joint action may cause IBS variation of actor-coactor pairs in frontal and parietal cortices. In comparison with the Comp condition (competitive intention), higher IBS should be found when participants were instructed to coordinate their movements in the Coop condition (cooperative intention).

Methods

Participants

Thirty-six adults (20 females and 16 males; 21.87 ± 2.60 years old) from colleges in the Tianjin province of China were included in the present study and received payment for their participation. All participants were right-handed, reported normal or corrected-to-normal vision and seldom exercised. They were randomly recruited and distributed into 18 pairs, and each actor/coactor pair was matched according to age, gender, sexual orientation, height and arm length. The members in each pair did not know each other before participation and signed prior informed consent before the experiment. The experimental processes were approved by the ethics committee of Tianjin Normal University.

Procedure

Before the experiment, participants were randomly assigned as actor-coactor pairs consisted of total strangers, and

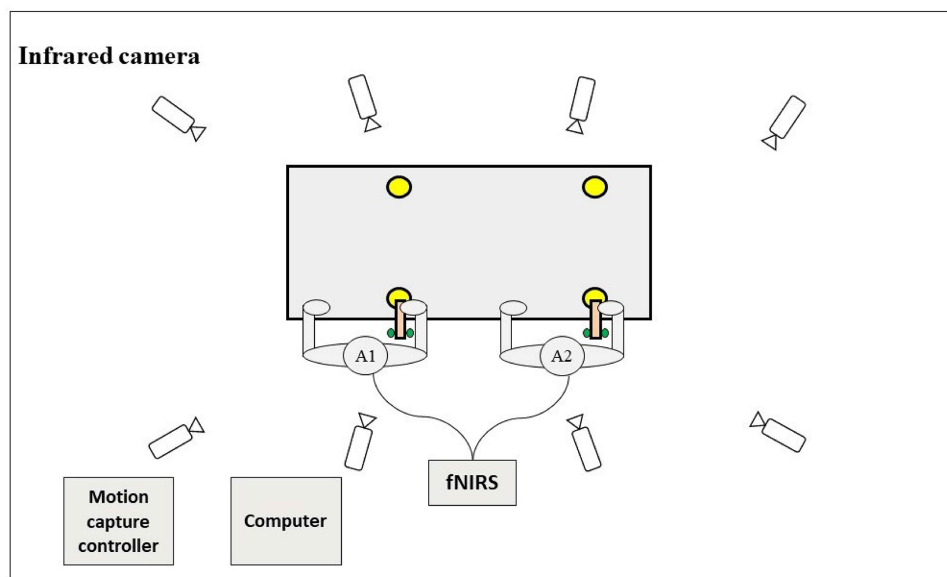

Fig. 1. Schematic demonstration of the experimental setting. A1 and A2 represent two different participants representing an actor/coactor pair. As shown in the figure, the movements of A1 and A2 were captured by eight infrared cameras that were connected to the motion capture controller.

communication with each other was deliberately forbidden. Two participants forming an actor/coactor pair were seated side by side along with the same table (120 cm in length, 60 cm in width and 78 cm in height), each holding a colloid rod (15.4 cm in height) in their right hand. The distance between the two participants was 61 cm, in order to meet the criterion of peripersonal space (Schmitz *et al.*, 2017). The general task was to move the rod back and forth between two circular targets (5 cm in diameter, 30 mm in height) made of sponges to lower the volume of the clicking sound and vibration of the table. The positions of the materials were arranged as described by Schmitz *et al.* (Figure 1). The edge of the table was 5 cm away from the close target and 45 cm away from the far target near the participant, which made an interval of 40 cm between the close target and the far target.

The entire experiment contained two testing sessions (Session A and Session B) that were completed sequentially: Session A included two single conditions: a self-paced (SP; move back and forth at a natural speed) condition and a fast-speed (FS; move as fast as possible) condition. In this session, each subject performed two blocks of 20 trials for each condition, for a total of 80 trials (eight blocks). During the experimental phase in Session A, the two participants completed the tasks alternately. They were separated by specific means to prevent any channels of sensory feedback (e.g. visual feedback, audio feedback and vibratory feedback) from each other. Specifically, a wooden block (1 cm in thickness, 60 cm in width and 55 cm in height) that fully blocked the sights of movements from each other was placed between actor/coactor pairs to control visual feedback. For vibratory feedback and audio feedback control, the two participants of actor/coactor pairs were asked to complete the SP and FS conditions alternately so that they do not perform movements at the same time: (i) participants who were not performing movements had to stay their hands away from the table and focused on their breath with a background white noise (20 db) played through the earphones and (ii) the acting participants moved the rod back and forth between the spongy

targets. To control order effects, half of the participants performed the SP condition before the FS condition, while the other half completed in a reverse manner.

Unlike Session A, Session B was executed by two participants at the same time under three distinct instructions: move at a natural speed and ignore your partner [no-intention (NI) condition], synchronize with your partner (Coop condition) or move faster than your partner (Comp condition). The NI condition, with minimal requirements to process other's actions, was added as the baseline for self-other processes. All conditions consisted of 3 blocks, with 10 trials per block.

In each trial, participants started the back-and-forth movement after a tone (688 Hz, 200 ms) played through earphones. A trial was defined as each time a participant performed a back-and-forth movement according to the start tone (688Hz, 200ms) that was played every 4 s, participants had to perform the back-and-forth movement after the start tone and remained stationary until the next cue once they moved back to the close target. According to van der Wel and Fu (2015), moving back and forth between the targets takes around 2 s. In order to prevent the potential influence of entrainment, the present study adopted a 4 s constrain on movement timing for creating discrete movement sequences. During the acting phase, participants were instructed to gently touch the spongy target. A background white noise (20 db) to further minimize action sounds from the partner was played during the entire experiment so that feedback concerning the coactor was primarily transmitted visually. Before fNIRS and the motion capture system began, the subjects completed 20 practice trials to familiarize themselves with the task. During the formal experiment, participants performed the single tasks first and then performed the joint tasks. The order of Session A was randomized. In Session B, the NI condition was fixed to avoid interference from subsequent trials, which formed a pseudo-randomized block design. To illustrate, half of the participants performed the experimental conditions in the order shown in the schematic illustration in Figure 2, whereas the other half of the participants did the reverse.

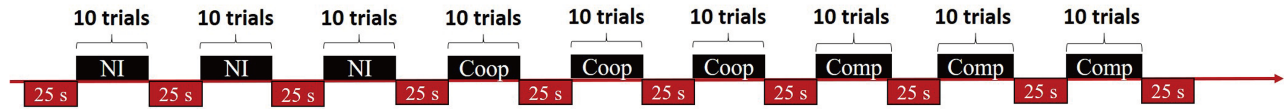

Fig. 2. Schematic illustration of the experimental design. As shown in the figure, every block consisted of 10 trials.

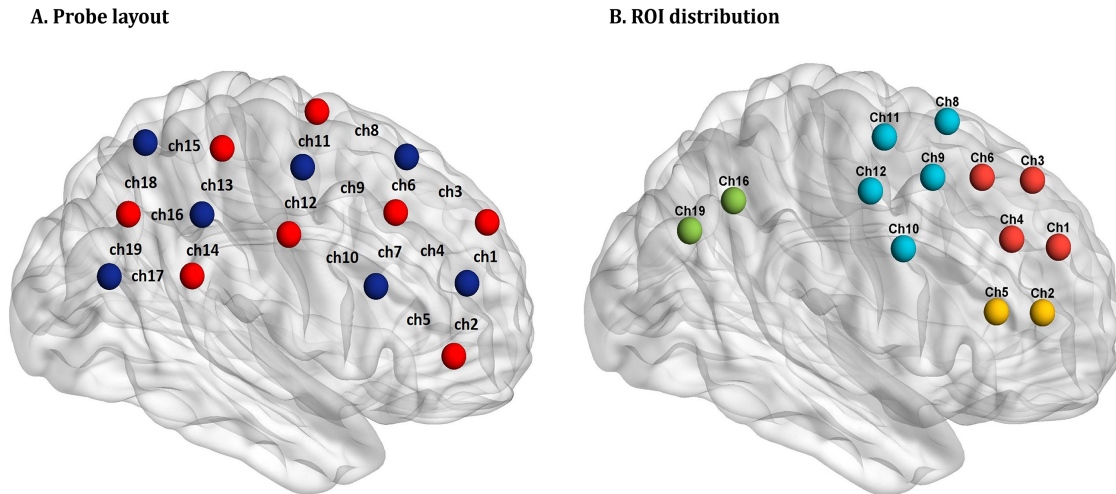

Fig. 3. Schematic illustration of probe set and ROI distribution. (A) Probe and channel positions of the layout (red dots denote emitters; blue dots denote detectors). (B) Four ROIs based on the anatomical regions of the brain. Ch1, Ch3, Ch4 and Ch6 correspond to the DLPFC (red); Ch2 and Ch5 correspond to the IFG (yellow); Ch8, Ch9, Ch10, Ch11 and Ch12 correspond to BA6 (blue); Ch16 and Ch19 correspond to the TPJ (green). The 3D surface visualizations of the probe set and ROI distribution were implemented using the BrainNetViewer (<http://www.nitrc.org/projects/bnv>) (Xia et al., 2013).

Behavioral data acquisition

A Nokov Optical 3D Motion Capture System (<http://www.nokov.com/en>) was used to obtain movement data of two motion capture markers attached to the top of the rod at a sampling rate of 100 Hz, the coordination system was established at the calibration phase by putting a calibration tool at the experimental table. Movement data were preprocessed using Cortex 6.0 to acquire spatial coordinates for each marker, which includes the displacements of the markers in the x - y - z axes over time. And the x - y - z axes represent the vertical axis (x), the longitudinal axis (y) and the horizontal axis (z), respectively.

fNIRS data acquisition

Cerebral oxygenation changes were recorded by a LABNIRS/16 (Shimadzu Corporation, Kyoto, Japan) with a sampling frequency of 55 Hz. A three-wavelength (780 ± 5 nm, 805 ± 5 nm and 830 ± 5 nm) semiconductor laser system (1M level under the IED-60825-1 standard) was used to monitor changes in cortical hemoglobin concentrations according to the modified Beer-Lambert law (MBLL).

Nineteen channels (8 emitters and 7 detectors) were measured via 3×3 and 3×2 optode arrays that were placed over the right hemisphere. Four regions of interest (ROIs) were defined as follows: dorsolateral prefrontal cortex (DLPFC), IFG, premotor and the supplementary motor cortex [Brodmann area (BA) 6] and TPJ (Figure 3). We performed optode positioning as described in the International 10–20 System to ensure consistency across participants. Table 1 presents the average MNI (Montreal Neurological Institute) coordinates and corresponding BA of the channels of interest across all participants. The locations of the channels were estimated using data from a 3D digitizer

(FASTRAK, Polhemus, Colchester, VT, USA) and a probabilistic registration method (Singh et al., 2005).

Data analysis

Behavioral data. Due to poor identification of both markers for one pair of participants, their movement data were abandoned in the preprocessing phase. Shifts in x -axis coordinates were then used to derive the MTs for the remaining 17 pairs of participants in each performed trial using MATLAB software (v. 2014a). MTs were defined as the time interval between the onset of the motion capture markers leaving the initial point (close target) and returning to the initial point. Each participant's MTs in all conditions was calculated by the movement trajectory of shifts in x -axis coordinates that better explained the displacement between close target and far target than other coordinates based on the sample rate of the motion capture system. The mean absolute asynchrony (Maa) that represented a measure of the motor coordination level in each actor/coactor pair was calculated with the following equation: $Maa = |AMT_{sp1} - AMT_{sp2}|$, where AMT_{sp1} is the average MTs of participant A1 associated with each condition, and AMT_{sp2} is the average MTs of participant A2 associated with each condition. That is, the absolute value of differences in averaged MTs between actor/coactor pairs under all experimental conditions were calculated as the 'Maa' (Schmitz et al., 2017 2018). The Maa of one pair was removed from the analyses (the Maa of this pair was outside ± 2 standard deviations of the mean of the conditions, which contained 95.4% variation). The standard deviation of the absolute asynchrony (s.d.aa) in each joint condition (30 trials in total) was also calculated as a further index of motor coordination to indicate trial by trial fluctuations between actor/coactor pairs

Table 1. Coordinates and BA of selected channels

Channel	MNI			BA	Overlap
	x	y	z		
Ch1	36	50	35	46—DLPFC	0.71
Ch3	25	41	52	9—DLPFC	0.77
Ch4	46	36	40	9—DLPFC	0.34
Ch6	37	26	56	9—DLPFC	0.57
Ch2	50	46	19	45—Pars triangularis of Broca's area	0.64
Ch5	57	32	21	45—Pars triangularis of Broca's area	1
Ch8	24	14	69	6—Premotor and supplementary motor cortex	0.52
Ch9	45	11	58	6—Premotor and supplementary motor cortex	0.5
Ch10	62	3	41	6—Premotor and supplementary motor cortex	0.72
Ch11	35	−5	67	6—Premotor and supplementary motor cortex	1
Ch12	54	−8	56	6—Premotor and supplementary motor cortex	0.50
Ch16	57	−51	53	40—Supramarginal gyrus of Wernicke's area	0.94
Ch19	44	−60	59	39—Angular gyrus of Wernicke's area	0.99

(Schmidt et al., 1990; Vesper et al., 2016). Statistical analyses were performed by means of repeated-measures ANOVAS (Analysis of Variance) and paired t-tests via SPSS (v.23.0).

fNIRS data

Intra-brain cognitive and neural processes. The software package, near-infrared spectroscopy-statistical parametric mapping (NIRS-SPM), was implemented in MATLAB (v. 2014a) to preprocess our fNIRS data in a manner that has been described previously (Ye et al., 2009). Each extracted fNIRS signal was denoised and drifted using the wavelet-minimum description length method (Jang et al., 2009). Through wavelet analysis and hemodynamic response functions, the drift and noise (e.g. head movements and heart rate) were eliminated. Then, an established reference wave combined with a general linear model was employed to evaluate the degree of the reaction induced by the experimental tasks in response to the reference wave (beta values) on all channels. Additionally, the temporal autocorrelation of this process was adjusted using the pre-coloring method. To obtain a relatively stable signal as the baseline, we retained the middle 8 s of the blood-oxygen-level-dependent (BOLD) signal during the rest state. Oxygenated hemoglobin concentrations were used for later analysis, as previous studies have found that this parameter is a more sensitive and reliable measure of fNIRS

compared with that of changes in deoxygenated hemoglobin concentrations (Strangman et al., 2003).

An ROI-based analysis was adopted for subsequent investigations. For a given ROI, beta values of the channels that belonged to a specific ROI according to their locations were averaged for every subject. Repeated measures of ANOVAs were performed on the ROI data under different conditions with SPSS (v.23.0), a P-value false-discovery-rate (FDR) correction was used for multiple comparisons at a threshold of $P < 0.05$.

Inter-brain neural coupling. The wavelet transform coherence package was used in MATLAB (v. 2014a) to calculate correlations between actor/coactor fNIRS signals in the frequency domain (Zhang et al., 2017). Based on our experimental design, the mean coherence values of actor/coactor pairs between 4 and 40 s after the start of each block were computed for the Coop and Comp conditions. Fisher's Z transformations were then performed for the above data. Subsequently, the IBS for each pair of channels within a defined ROI were averaged. Statistical analyses of the IBS were performed by means of paired t-tests.

Data visualization was implemented using GraphPad Prism (v.8.0) and the 'EasyTopo toolbox' (Tian et al., 2013) in MATLAB (v. 2014a).

Results

Behavioral results

MTs. There were no significant differences between the MTs from the SP and FS tasks ($t(33) = 1.48$, $P > 0.05$, $d = 0.25$). For comparisons of joint conditions, MTs was separately analyzed via a repeated one-way ANOVA. The results revealed significant differences for MTs among joint conditions ($F_{(2,66)} = 20.27$, $P < 0.001$, $\eta_p^2 = 0.38$). Post hoc tests (Turkey's multiple comparisons) revealed that MTs in the NI condition were significantly longer than the Coop condition ($P < 0.05$) and the Comp condition ($P < 0.001$), and also longer MTs for the Coop condition than the Comp condition ($P < 0.001$). To compare joint vs single differences, a series of paired t-tests was conducted between Coop and SP, NI and SP, as well as Comp and FS. MTs of actors were significantly shorter in the Coop and Comp conditions than in the corresponding single conditions (Coop vs SP: $t(33) = -2.56$, $P < 0.05$, $d = -0.44$; Comp vs FS: $t(33) = -4.77$, $P < 0.001$, $d = -0.82$), whereas no significant effect was found between MTs in the NI and SP conditions (NI vs SP: $t(33) = -0.36$, $P > 0.05$, $d = -0.06$). For more details, see Figure 4.

Control analysis was added to investigate how actors adapt to their coactors' movement in the joint conditions. The participants were split into four groups (fast-SP, slow-SP, fast-FS and slow-FS) according to the MTs that they spent to fulfill the SP or the FS back-and-forth movement (e.g. participant A1 belongs to the faster group SP if he/she has shorter MTs than participant A2 in the SP condition). Thus, MTs of those participants who acted faster or slower than their partners during single conditions were compared with their performances during the corresponding joint conditions to find out if there are different speed adjustments for actors themselves who had different speed profiles. The analyses showed significant differences for the performances of slow groups acting in the single conditions and in the joint conditions but not for the faster groups. For more details, see Table 2. According to the results, participants who have slower speed profiles typically sped up trying to catch up with the faster actors in actor/coactor pairs. This

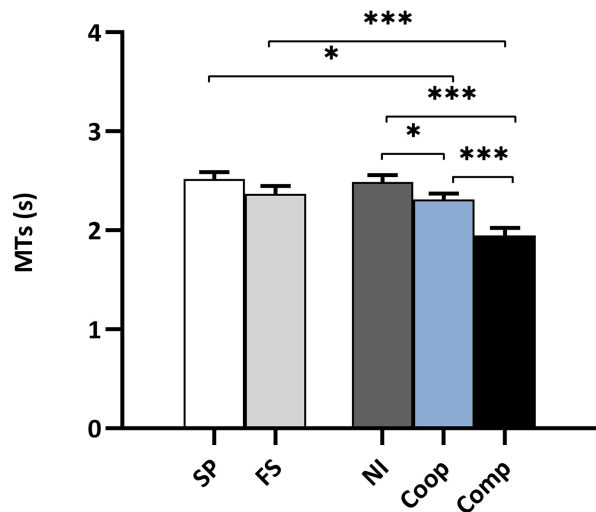

Fig. 4. Mean MTs under all conditions. Error bars denote standard error of the mean (SEM; * $P < 0.05$, *** $P < 0.001$).

Table 2. The contrast between different groups under single and joint conditions

Group	Contrast	t	df	P	Cohen's d
Fast-SP	SP vs NI	-1.71	16	0.11	-0.41
	SP vs Coop	-0.92	16	0.37	-0.22
Slow-SP	SP vs NI	2.48	16	<0.05	0.60
	SP vs Coop	6.79	16	<0.001	1.65
Fast-FS	FS vs Comp	1.26	16	0.22	0.30
Slow-FS	FS vs Comp	7.84	16	<0.001	1.90

effect happened during all joint conditions, and the NI condition seems to have a minimal impact on it, suggesting that prior intentions might facilitate the movement adjustments of actors belong to the slow groups.

Maa and its fluctuations. For the Maa of those actor/coactor pairs, the data of one pair that left outside ± 2 standard deviations of the mean of the conditions was removed from analyses. And the results showed no differences in the three joint conditions, $F(2, 30) = 1.95$, $P > 0.05$, $\eta_p^2 = 0.12$. To confirm the significance of the Maa, we compared the joint conditions to asynchrony when acting alone by pretending that the two single actors were in a joint condition. The results showed that actor/coactor pairs were more asynchronous in the SP condition than in the Coop condition ($t(15) = 2.41$, $P < 0.05$, $d = 0.60$), whereas no differences were found between the SP condition and the NI condition ($t(15) = 0.73$, $P > 0.05$), as well as the FS condition and the Comp condition ($t(15) = 0.28$, $P > 0.05$). This pattern of results reveals that actor/coactor pairs synchronized their movements to a larger degree only in a Coop context. The analysis is supportive of our experimental manipulation since actor/coactor pairs were demanded to synchronize their movements specifically in the Coop condition rather than other conditions. A repeated one-way ANOVA was applied on the s.d.aa between actor/coactor pairs to compare the movement fluctuations of actor/coactor pairs in the joint conditions. The results showed a significant effect of condition, $F(2, 30) = 4.0$, $P < 0.05$, $\eta_p^2 = 0.21$. Further analyses showed that both the Coop condition and the Comp condition had higher fluctuations in

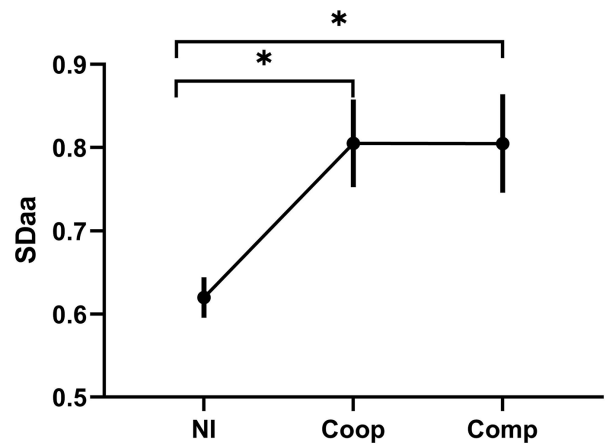

Fig. 5. s.d.aa between actor/coactor pairs in the NI, Coop and Comp conditions. Error bars denote SEM.

comparisons with the NI condition ($P < 0.05$, Figure 5), whereas no differences were found between the Coop and the Comp condition.

Intra-brain activation

There were no significant differences in the fNIRS signals of any ROIs between the two single conditions (SP and FS). To determine if the rTPJ was more activated in tasks that required processing of self-other distinction or self-other merging, a repeated one-way ANOVA of the rTPJ-specific fNIRS signals among the three joint conditions (NI, Coop and Comp) was conducted and revealed that this parameter was significantly different across these conditions ($F(2, 70) = 4.1$, $P < 0.05$, $\eta_p^2 = 0.11$). Descriptive statistics showed that the mean rTPJ activities were the highest in the Comp condition, and the lowest in the NI condition. Pairwise comparisons revealed significant stronger rTPJ activities in the Comp condition than in the NI condition ($P < 0.05$, Figure 6), but the difference between the NI condition and the Coop condition failed to reach statistical significance ($P > 0.05$), as well as the Coop condition and the Comp condition ($P > 0.05$). Besides, there was no correlation between MTs and fNIRS signals within the rTPJ.

We found ROI-specific differences for the comparisons of joint vs single conditions. Specifically, between the NI and SP conditions, the NI condition showed a significantly higher activation in BA6 ($t(35) = 3.47$, $P_{FDR} < 0.05$, $d = 0.58$) and DLPFC ($t(35) = 2.15$, $P < 0.05$, $d = 0.36$, uncorrected). For Coop vs SP, the Coop condition showed greater activation in BA6 ($t(35) = 3.1$, $P_{FDR} < 0.05$, $d = 0.52$). All ROIs (except the IFG) were more strongly activated in the Comp condition compared with those in the FS condition, but only difference in BA6 activation remained statistically significant after FDR correction ($t(35) = 3.67$, $P_{FDR} < 0.01$, $d = 0.61$; Figure 7). There was no significant correlation between MTs and activation of the BA6.

Inter-brain coupling

As determined by paired t-tests of averaged IBS between Coop and Comp conditions, there were no significant differences between any ROIs (DLPFC: $t(17) = -0.06$, $P > 0.05$, $d = -0.02$; IFG: $t(17) = -0.56$, $P > 0.05$, $d = -0.13$; BA6: $t(17) = -0.20$, $P > 0.05$, $d = 0.05$; TPJ: $t(17) = -0.34$, $P > 0.05$, $d = -0.08$).

A. Hemodynamic changes of the TPJ in the joint conditions B. A *t*-map of Comp versus NI contrast in the ROIs

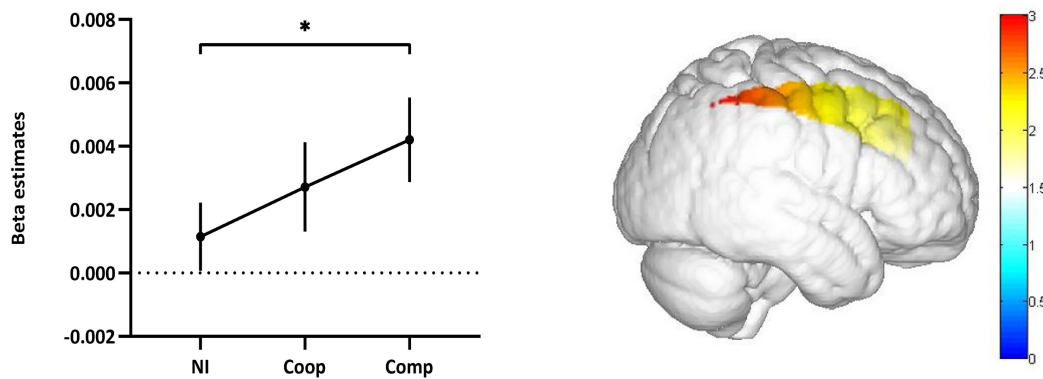

Fig. 6. (A) Activation patterns of the TPJ in the NI, Coop and Comp conditions, Error bars denote SEM. (B) Brain areas that are more activated in the Comp condition than in the NI condition.

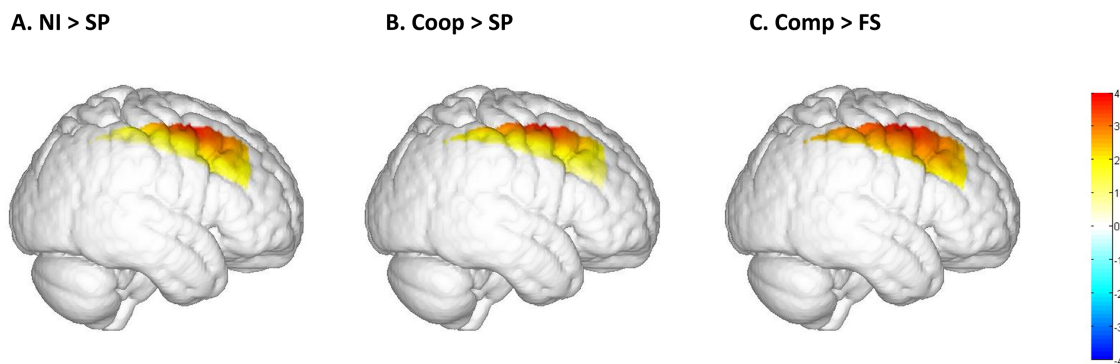

Fig. 7. Schematic of *t*-maps calculated from paired *t*-tests between the joint conditions and corresponding single conditions. (A) NI vs SP contrast. (B) Coop vs SP contrast. (C) Comp vs FS contrast.

Discussion

The differences between the single action and joint action

In joint conditions, participants acted together with prior Coop or Comp intentions, or with no prior intention of any kind. Significantly shorter MTs were observed in both Coop and Comp joint tasks compared with those in corresponding single tasks with similar demands. These results are consistent with the findings of Georgiou *et al.*, (2007), such that prior Coop or Comp intentions influenced the movement kinematics of a similar motor task performed alone. Although actor-coactor pairs also performed our task together in the NI condition, motor performance in a joint context without any requirements to interact with the paired coactor is not influenced, further corroborating previous studies that motor adjustments during joint action occur only when actors have prior interactive intentions. Compared with those in the SP condition, shorter MTs in the Coop condition might reflect a strategy for decreasing movement variation via more quickly executed movements on the basis of a Coop intention (Vesper *et al.*, 2010). Additionally, faster movement speeds in the Comp condition may be driven by social comparison processes initiated from a prior Comp intention.

Further analysis showed that the motor speed of slower participants in actor-coactor pairs of the single conditions was accelerated in all joint conditions irrespective of the prior intention. This might be caused by the presence of a coaching partner that may facilitate motor coordination between individuals.

Higher levels of fNIRS-signal activation were found in the BA6 in all joint conditions compared with those in single conditions, which is consistent with our original hypothesis. This area is engaged in the motor execution (Toyokura *et al.*, 2002), motor plan updating (Gremel and Costa, 2013), action representation maintenance (Stadler *et al.*, 2011) and bimanual coordination (Obhi *et al.*, 2002). Moreover, action planning is considered to be a core function of BA6, and neural activities in this region have been shown to increase as a function of the complexity of movement planning (Tanji, 1994; Isoda and Tanji, 2004). Since correlation analysis in the present study revealed that there was no linear relationship between MTs and increased activation in BA6, we speculated that the strengthened hemodynamic responses in the joint tasks were unrelated to the processing of motor execution but corresponded to more complex planning in joint settings compared with that in single-actor settings, which may also suggest that BA6 plays an important role in some aspects of joint tasks.

The differences between the Coop joint action and the Comp joint action

Humans might process other's actions unintentionally, although other's actions or intentions are unrelated to their current action goal (Sebanz et al., 2005). In our research, performing the same task next to each other simultaneously elicited stronger activities in BA6 than performing that task solely, even when being told to ignore the partner (i.e. the NI condition). In order to counteract the influence of others on self-movement performance, we introduced the NI condition as a baseline to investigate the modulation of prior intentions on joint action.

Participants showed significant differences in performing differently intentioned joint tasks. Shorter MTs were not only found in the Coop and Comp condition than in the NI condition, but also in the Comp condition than in the Coop condition. Thus, the shortest MTs were found in the Comp condition, whereas the longest MTs were found in the NI condition. The results above might suggest a modulation of prior intentions on motor performance. Given the need to be faster than others in the Comp condition and the requirement of synchronization with others in the Coop condition, the motor performance was influenced accordingly.

Intra-brain activation differences in the rTPJ among the NI, Coop and Comp conditions revealed that the highest activities occurring in the Comp condition. Two possible reasons for these results are as follows: (i) there were faster movements in the Comp condition and/or (ii) there were higher degrees of self-other processes. As a result of there being no significant correlation between rTPJ activities and MTs, hemodynamic changes in the rTPJ are likely associated with self-other processes. According to previous studies, some researchers had discovered the role of the TPJ in self-other distinction (Decety et al., 2004), others supported that the TPJ was related to self-other merging (Abe et al., 2019). In our results, the Coop condition and the NI condition showed no difference whereas the Comp condition and the NI condition differed significantly in rTPJ activities—an area that maybe more involves in self-other distinction (Farrer and Frith, 2002; Uddin et al., 2006). In the present study, rTPJ activities have been weakest in the NI condition because there were least requirements to process others in this context, which would involve the fewest degrees of self-other distinction among three joint conditions. Prior Coop and Comp intentions have been proved to guide the self-other processes, but fewer degrees of self-other distinction happened in the Coop context than in the Comp context (De Cremer and Stouten, 2003; Decety et al., 2004; Ruissen and de Bruijn, 2016). In Ruissen and Bruijn's experiment, self-other distinction processes were indexed by the social Simon effect (van der Weiden et al., 2016). The study demonstrated that an established Coop or Comp relationship is sufficient to modulate the degree of self-other distinction processes on joint task performance. A Comp relationship contrast with a Coop relationship may result in more individual task performance, participants under the Comp condition are more concerned with individual thinking. For example, participants need to compare their performance with coactors to figure out whether they moved faster than others. While in the Coop condition, self-other processes shifted from distinction to merging, emphasizing the integration of one's own and other's performance (Sacheli et al., 2019). Therefore, the Coop intention has a lower relevance to self-other distinction processes than

the Comp intention. Maybe that was the reason for the weaker results of TPJ in coop condition.

The Maa—as a measure of the coordination performance between actor/coactor pairs—was not significantly different among the three joint tasks. In contrast, the fact that MTs differed across the three joint tasks but the Maa of those different MTs were similar suggests that the synchronies of actor/coactor pairs were consistent across all joint tasks in different MTs. Due to the simple characteristics of the experimental task in the present study—which placed minimal demands on coordination by asking two participants to carry out symmetric back-and-forth movements simultaneously—actor/coactors were able to achieve action coordination at different speeds. Although no effects have been found on 'Maa', actor/coactor pairs were more synchronous during the Coop condition than the SP condition, while they exhibited similar degrees of synchrony during the Comp condition and the FS condition, as well as the NI condition and the SP condition. Since the participants were instructed to synchronize their movements in the Coop condition, the Maa could be interpreted as a measure of coordination performance.

The standard deviation of the absolute synchrony—as a measure of the fluctuations in coordination performance—was significantly weaker in the NI condition than in the Coop and the Comp condition, whereas no differences were found between the Coop and the Comp condition. Combining with the shorter MTs in the Comp condition than in the Coop condition, it revealed a pattern that the MTs differed under Coop and Comp intentions but fluctuated equally. This might reflect the modulation of the intentional content on interpersonal motor coordination in the forms of movement adjustment and self-correction processes. The motor adjustment among individuals on different trials exhibited the effect of prior intentions on motor coordination: to be more synchronous in the next trial (cooperation) or to be faster in the next trial (competition). This might lead to higher movement fluctuations in the Coop and the Comp condition than in the NI condition. For instance, participants who tried to synchronize with their partners in the Coop condition would notice the extent of synchronization in the present trial and adjust their movements accordingly in the next trial. When competing against their partners in the Comp condition, the movement fluctuations might indicate self-correction processes to improve performance.

No significant differences in IBS between Coop and Comp conditions were found in BA6 or in any other ROIs. The behavioral finding that there were no differences in mean absolute asynchronies may explain why we did not find any inter-brain differences in motor coordination-related brain areas.

Further studies are needed to address some questions remained in the present study: (i) the complexity of the motor task should be elevated to better observe the behavioral and IBS of interpersonal motor coordination; (ii) the extent of TPJ role in self-other distinction and self-other merging should be further investigated to decide if TPJ activities are unique to self-other distinction in interpersonal coordination; (iii) more effective measurement methods are needed to explore the cognitive and neural mechanisms of interpersonal motor coordination. Although the fNIRS has the advantage of high motion tolerance for the investigation of interpersonal motor coordination, it also has deficiencies in spatial resolution compared with fMRI. Along with individual differences, it might affect the sensitivity of the experimental results.

Conclusion

In conclusion, participants performed the back-and-forth movement task with shorter MTs and stronger activities in BA6 under the joint Coop and Comp conditions than under the single conditions. However, there were no differences in the mean absolute asynchronies or IBS between actor/coactor pairs between the Coop and Comp conditions. Our results support the functional relationship between the rTPJ and the self-other distinction processes that were guided by prior intentions.

Acknowledgments

We thank LetPub (www.letpub.com) for its linguistic assistance during the preparation of this manuscript. We are thankful for Dr Yin Liu for her help in recruiting the participants.

Funding

This work was supported by a major project from the Key Research Base of Humanities and Social of the Ministry of Education (Grant no. 18JJD190001), and the Cheung Kong Scholars Programme of China (Grant no. T2017120).

Conflict of interest

The authors have no conflicts of interest to report with this work.

References

- Abdalmalak, A., Milej, D., Cohen, D.J., et al. (2020). Using fMRI to investigate the potential cause of inverse oxygenation reported in fNIRS studies of motor imagery. *Neuroscience Letters*, 714, 134607.
- Abe, M.O., Koike, T., Okazaki, S., et al. (2019). Neural correlates of online cooperation during joint force production. *NeuroImage*, 191, 150–61.
- Babiloni, F., Astolfi, L. (2014). Social neuroscience and hyper-scanning techniques: past, present and future. *Neuroscience and Biobehavioral Reviews*, 44, 76–93.
- Decety, J., Jackson, P.L., Sommerville, J.A., Chaminade, T., Meltzoff, A.N. (2004). The neural bases of cooperation and competition: an fMRI investigation. *NeuroImage*, 23(2), 744–51.
- De Cremer, D., Stouten, J. (2003). When do people find cooperation most justified? The effect of trust and self-other merging in social dilemmas. *Social Justice Research*, 16(1), 41–52.
- Doerrfeld, A., Sebanz, N., Shiffrar, M. (2012). Expecting to lift a box together makes the load look lighter. *Psychological Research*, 76(4), 467–75.
- Egetemeir, J., Stenneken, P., Koehler, S., Fallgatter, A.J., Herrmann, M.J. (2011). Exploring the neural basis of real-life joint action: measuring brain activation during joint table setting with functional near-infrared spectroscopy. *Frontiers in Human Neuroscience*, 5, 95.
- Farrer, C., Frith, C.D. (2002). Experiencing oneself vs another person as being the cause of an action: the neural correlates of the experience of agency. *NeuroImage*, 15(3), 596–603.
- Georgiou, I., Becchio, C., Glover, S., Castiello, U. (2007). Different action patterns for cooperative and competitive behaviour. *Cognition*, 102(3), 415–33.
- Gremel, C., Costa, R. (2013). Premotor cortex is critical for goal-directed actions. *Frontiers in Computational Neuroscience*, 7, 110.
- Isoda, M., Tanji, J. (2004). Participation of the primate presupplementary motor area in sequencing multiple saccades. *Journal of Neurophysiology*, 92(1), 653–59.
- Jang, K.E., Tak, S., Jung, J., Jang, J., Jeong, Y., Ye, Y.C. (2009). Wavelet minimum description length detrending for near-infrared spectroscopy. *Journal of Biomedical Optics*, 14(3), 034004.
- Kokal, I., Gazzola, V., Keysers, C. (2009). Acting together in and beyond the mirror neuron system. *NeuroImage*, 47(4), 2046–56.
- Milward, S.J., Sebanz, N. (2016). Mechanisms and development of self-other distinction in dyads and groups. *Philosophical Transactions of the Royal Society B: Biological Sciences*, 371(1686), 20150076.
- Newman-Norlund, R.D., Bosga, J., Meulenbroek, R.G., Bekkering, H. (2008). Anatomical substrates of cooperative joint-action in a continuous motor task: virtual lifting and balancing. *NeuroImage*, 41(1), 169–77.
- Nozawa, T., Sasaki, Y., Sakaki, K., Yokoyama, R., Kawashima, R. (2016). Interpersonal frontopolar neural synchronization in group communication: an exploration toward fNIRS hyper-scanning of natural interactions. *NeuroImage*, 133, 484–97.
- Obhi, S.S., Haggard, P., Taylor, J., Pascual-Leone, A. (2002). rTMS to the supplementary motor area disrupts bimanual coordination. *Motor Control*, 6(4), 319–32.
- Ondobaka, S., de Lange, F.P., Newman-Norlund, R.D., Wiemers, M., Bekkering, H. (2012). Interplay between action and movement intentions during social interaction. *Psychological Science*, 23(1), 30–5.
- Pezzulo, G., Iodice, P., Donnarumma, F., Dindo, H., Knoblich, G. (2017). Avoiding accidents at the champagne reception: a study of joint lifting and balancing. *Psychological Science*, 28(3), 338–45.
- Ruissen, M.I., de Bruijn, E. (2016). Competitive game play attenuates self-other integration during joint task performance. *Frontiers in Psychology*, 7, 274.
- Sacheli, L.M., Verga, C., Arcangeli, E., Banfi, G., Tettamanti, M., Paulesu, E. (2019). How task interactivity shapes action observation. *Cerebral Cortex*, 29(12), 5302–14.
- Sänger, J., Müller, V., Lindenberger, U. (2012). Intra- and inter-brain synchronization and network properties when playing guitar in duets. *Frontiers in Human Neuroscience*, 6, 312.
- Sebanz, N., Bekkering, H., Knoblich, G. (2006). Joint action: bodies and minds moving together. *Trends in Cognitive Sciences*, 10(2), 70–6.
- Sebanz, N., Knoblich, G., Prinz, W. (2005). How two share a task: corepresenting stimulus-response mappings. *Journal of Experimental Psychology: Human Perception and Performance*, 31(6), 1234–46.
- Schilbach, L., Timmermans, B., Reddy, V., et al. (2013). Toward a second-person neuroscience. *Behavioral and Brain Sciences*, 36(4), 393–414.
- Schmidt, R.C., Carello, C., Turvey, M.T. (1990). Phase transitions and critical fluctuations in the visual coordination of rhythmic movements between people. *Journal of Experimental Psychology: Human Perception and Performance*, 16(2), 227–47.
- Schmitz, L., Vesper, C., Sebanz, N., Knoblich, G. (2017). Co-representation of others' task constraints in joint action. *Journal of Experimental Psychology: human Perception and Performance*, 43(8), 1480–93.
- Schmitz, L., Vesper, C., Sebanz, N., Knoblich, G. (2018). Co-actors represent the order of each other's actions. *Cognition*, 181, 65–79.

- Shima, K., Mushiake, H., Saito, N., Tanji, J. (1996). Role for cells in the presupplementary motor area in updating motor plans. *Proceedings of the National Academy of Sciences*, 93(16), 8694–8.
- Singh, A.K., Okamoto, M., Dan, H., Jurcak, V., Dan, I. (2005). Spatial registration of multichannel multi-subject fNIRS data to MNI space without MRI. *NeuroImage*, 27(4), 842–51.
- Stadler, W., Schubotz, R.I., Von Cramon, D.Y., Springer, A., Graf, M., Prinz, W. (2011). Predicting and memorizing observed action: differential premotor cortex involvement. *Human Brain Mapping*, 32(5), 677–87.
- Strangman, G., Franceschini, M.A., Boas, D.A. (2003). Factors affecting the accuracy of near-infrared spectroscopy concentration calculations for focal changes in oxygenation parameters. *NeuroImage*, 18(4), 865–79.
- Tanji, J. (1994). The supplementary motor area in the cerebral cortex. *Neuroscience Research*, 19(3), 251–68.
- Tian, F., Lin, Z. J., and Liu, H. (2013). EasyTopo: a toolbox for rapid diffuse optical topography based on a standard template of brain atlas. *Proceeding SPIE*, 8578, 85782J.
- Toyokura, M., Muro, I., Komiya, T., Obara, M. (2002). Activation of pre-supplementary motor area (SMA) and SMA proper during unimanual and bimanual complex sequences: an analysis using functional magnetic resonance imaging. *Journal of Neuroimaging*, 12(2), 172–8.
- Tsai, -C.-C., Kuo, W.-J, Jing, J.-T., Hung, D.L., Tzeng, O.J.-L. (2006). A common coding framework in self-other interaction: evidence from joint action task. *Experimental Brain Research*, 175(2), 353–62.
- Uddin, L.Q., Molnar-Szakacs, I., Zaidel, E., Iacoboni, M. (2006). rTMS to the right inferior parietal lobule disrupts self-other discrimination. *Social Cognitive and Affective Neuroscience*, 1(1), 65–71.
- van der Weiden, A., Aarts, H., Prikken, M., van Haren, N. (2016). Individual differences in action co-representation: not personal distress or subclinical psychotic experiences but sex composition modulates joint action performance. *Experimental Brain Research*, 234(2), 499–510.
- van der Wel, P, Fu, E. (2015). Entrainment and task co-representation effects for discrete and continuous action sequences. *Psychonomic Bulletin & Review*, 22(6), 1685–91.
- Vesper, C., Butterfill, S., Knoblich, G., Sebanz, N. (2010). A minimal architecture for joint action. *Neural Networks*, 23(8–9), 998–1003.
- Vesper, C., Schmitz, L., Safra, L., Sebanz, N., Knoblich, G. (2016). The role of shared visual information for joint action coordination. *Cognition*, 153, 118–23.
- Vesper, C., van der Wel, P, Knoblich, G., Sebanz, N. (2011). Making oneself predictable: reduced temporal variability facilitates joint action coordination. *Experimental Brain Research*, 211(3–4), 517–30.
- Vesper, C., van der Wel, R.P., Knoblich, G., Sebanz, N. (2013). Are you ready to jump? Predictive mechanisms in interpersonal coordination. *Journal of Experimental Psychology. Human Perception and Performance*, 39(1), 48–61.
- Wilson, M., Knoblich, G. (2005). The case for motor involvement in perceiving conspecifics. *Psychological Bulletin*, 131(3), 460–73.
- Xia, M., Wang, J., He, Y., Csermely, P. (2013). BrainNet Viewer: a network visualization tool for human brain connectomics. *PLoS One*, 8(7), e68910.
- Ye, J.C., Tak, S., Jang, K.E., Jung, J., Jang, J. (2009). NIRS-SPM: statistical parametric mapping for near-infrared spectroscopy. *NeuroImage*, 44(2), 428–47.
- Zhang, M., Liu, T., Pelowski, M., Yu, D. (2017). Gender difference in spontaneous deception: a hyperscanning study using functional near-infrared spectroscopy. *Scientific Reports*, 7(1), 7508.