



Relationships between Dark Triad and negative emotions during COVID-19 lockdown: The chain mediating roles of negative coping and state boredom

Minqi Yang^{1,2} · Chunyu Qu¹ · Zehao Zhang¹ · Hanxiao Guo¹ · Xicheng Guo¹ · Liuqi Yang³ · Kexin Tian¹ · Wanying Hu¹

Accepted: 22 July 2022

© The Author(s), under exclusive licence to Springer Science+Business Media, LLC, part of Springer Nature 2022

Abstract

Personality is distal vulnerability of negative emotions and vital to mental health. Dark Triad was significantly correlated with negative emotions, whereas the mechanisms beneath the relationships were less clear. Based on life history strategy theory (LHS) and cognitive vulnerability-transactional stress model, the study explored the relationships between Dark Triad and negative emotions and investigated the roles of negative coping style and state boredom in the relationships aforementioned during the strict period of COVID-19 lockdown in China. 464 participants ($M_{age} = 36.78$ years; $SD = 10.53$) finished a package of measurements online including Depression Anxiety and Stress Scale (DASS-21), Short Dark Triad (SD3), Multidimensional State Boredom Scale (MSBS), and Simplified Coping Style Questionnaire (SCSQ). The results showed there were positive relationships between Dark Triad and depression, anxiety and stress. Moreover, the relationships between Dark Triad and negative emotions were sequentially mediated by negative coping style and state boredom. The present study offered fascinating perspectives in the relationships between Dark Triad and negative emotions, and revealed how Dark Triad affected depression, anxiety and stress during the initial phase of COVID-19 pandemic and strict lockdown among Chinese population. The present results may provide important implications for the prevention and intervention of depression, anxiety and stress during COVID-19 pandemic and lockdown. Specifically, the intervention strategies that focus on reducing Dark Triad, negative coping and boredom may help offset occurrence of negative emotional states.

Keywords Dark Triad · Depression · Anxiety · Stress · Coping style · State boredom

✉ Wanying Hu
huwanying66@163.com; 240332398@qq.com

Minqi Yang
minqi_yang@zzu.edu.cn

Chunyu Qu
1099364310@qq.com

Zehao Zhang
ymqbest204@126.com

Hanxiao Guo
2540547763@qq.com

Xicheng Guo
xich9423@163.com

Liuqi Yang
1422953872@qq.com

Kexin Tian
2500799149@qq.com

¹ School of Education, Zhengzhou University,
450001 Zhengzhou, China

² School of Marxism, Zhengzhou University,
450001 Zhengzhou, China

³ School of Water Conservancy Science and Engineering,
Zhengzhou University, 450001 Zhengzhou, China

Introduction

Depression, anxiety and stress are typically known as negative emotions (Geng et al., 2020) and overlap extensively with general psychological distress being shared (Anyan & Hjemdal, 2016; Hankin et al., 2004; Henry & Crawford, 2005). With the outbreak of COVID-19 pandemic, China quickly started the lockdown and people in China had to stay at home, suffering from fear of infection, enormous negative news, and no face-to-face interaction with other people, which made the negative emotions overwhelmingly prevalent. For example, during COVID-19 lockdown, more than one half of Chinese healthcare workers had symptoms of depression and anxiety (Lai et al., 2020; Xiao et al., 2020), and the general public was no exception (Hou et al., 2020; Wang et al., 2020). Diverse detrimental outcomes generated following depression, anxiety and stress, including but not limited to insomnia (Alvaro et al., 2013), and suicidal behaviors (Frison & Eggermont, 2016). Identifying the potential risks of these negative emotions is a priority issue to prevention and intervention for mental health problems, especially during the stressful worldwide pandemic period.

Dark Triad and negative emotions

Dark Triad, a subclinical maladaptive and socially aversive personality cluster, is composed of three distinct but overlapping traits including Machiavellianism, narcissism, and psychopathy (Paulhus & Williams, 2002; Rahafar et al., 2017). Machiavellianism is uniquely characterized by cynicism, hypocrisy and manipulation (Gómez-Leal et al., 2019), narcissism focuses on self-exaggeration and pursuit of superiority (Yang et al., 2019), and psychopathy refers to callousness, impulsivity, aggression and antisocial behaviors (Rahafar et al., 2017). Common cores among them are empathy deficit, low agreeableness, selfish behaviors and cold interpersonal orientation (Furnham et al., 2014; Paulhus & Williams, 2002).

Life history strategy theory (LHS) is a mid-level evolutionary theory that describes the trade-offs individuals make in energy allocation toward different life tasks: (a) maintaining and facilitating their own growing, and (b) devoting to mating and parenting (Rushton, 1985). The particular pattern of energy allocation depends on the harshness and unpredictability of the environment (Ellis et al., 2009). Accumulation of multiple risks would construct environment with insufficient and unpredictable resources and motivate individuals to select fast life history strategy (Ellis et al., 2009; Furnham et al., 2013). These individuals produce more offspring, but invest less in each offspring, have preference for immediate satisfaction and short-term

benefits (Carter et al., 2014; Ellis et al., 2009; Furnham et al., 2013; Rauthmann & Kolar, 2013), but reduce allotment of energy to development which may therefore be associated with lower ability to obtain resources, status, long-term mates (Wilson et al., 1996), and mental well-being (Martin et al., 2012). Evidences have shown that Dark Triad is the indicator of the fast life history strategy (Jonason et al., 2010; McDonald et al., 2012).

Literature related to Dark Triad and depression, anxiety, and stress is sprouting up since COVID-19. However, these mainly involved the negative effects of dark traits on depression and anxiety (Gogola et al., 2021; Lyons et al., 2019), and the negative effects of single Dark Triad trait on negative emotions (Saltoğlu & Uysal Irak, 2020; Truhan et al., 2022). Studies regarding the effects of whole Dark Triad on three negative emotions and their mechanisms are limited. To our knowledge, merely one study has surveyed the potential mechanisms beneath the relationships between Dark Triad and negative emotions from perspectives of maladaptive and adaptive cognitive emotion regulation strategy (Mojsa-Kaja et al., 2021), but it is not adequate and comprehensive to understand the mechanisms. Additionally, most studies regarding Dark Triad have been conducted using western populations, with few using Chinese populations, especially in the initial period of COVID-19 pandemic with strict COVID-19 lockdown regulations in China. Culture would exert its influence on the personality and psychopathology (Lewis-Fernández & Kleinman, 1994). Thus the current study aimed to explore the relationships between Dark Triad and depression, anxiety and stress during the initial phase of COVID-19 pandemic (from 20th February to 10th March, 2020) among Chinese population and the underlying mechanisms.

The mediating role of negative coping style

Some researchers demonstrated that maladaptive personality is a distal factor vulnerable to negative emotions (Hankin & Abramson, 2001; Hankin et al., 2004). Based on cognitive vulnerability-transactional stress model (Hankin & Abramson, 2001; Hankin et al., 2004), negative events and personality stimulate individuals' negative vulnerability, i.e., mainly negative coping style and dysfunctional attitudes, which lead to increased negative emotions. Thus we postulated negative coping style may mediate the relationships between Dark Triad and depression, anxiety, and stress.

Coping styles reflect individuals' strategies to deal with life events (Lazarus & Folkman, 1987) and intentional regulations including adjustment of evaluation on stressful events and of behavioral and emotional reactions to events (Neufeld, 1989). Such efforts can be described as negative

or positive (Berman et al., 1996). Negative coping (e.g., distraction, withdrawal, self-criticism, aggression, blaming others, wishful thinking, resignation) consists of asocial or antisocial avoidant behaviors that are not focused on the stressor itself, and positive coping strategies (e.g., problem-solving efforts, seeking information, social support) include prosocial behaviors focused on self-care or changing the problem situation (Dempsey, 2002). In general, it has been shown that positive, problem-focused strategies have been related to better outcomes, whereas negative, avoidant strategies have been associated with greater difficulties (Altshuler & Ruble, 1989). Negative coping could cause failure in dealing with external and internal stimuli, which may immerse individuals in negative states (Zhang et al., 2021). Empirical studies have shown depression was positively associated with avoidant and emotion-focused coping strategies (Nagase et al., 2009), and depression and anxiety were also positively correlated with negative coping style (Shao et al., 2020).

Strong correlations between coping styles and Dark Triad have also been evidenced. For example, Machiavellianism was correlated with emotional coping strategies (Rim, 1992). Recently, researchers found Machiavellianism and psychopathy were negatively associated with task-oriented coping and positively with the emotional-oriented coping process suggesting a more emotional reaction to stress, which was consistent with Rim's finding, whereas narcissism was associated with task-oriented and emotional-oriented coping (Birkas et al., 2016). Furthermore, empirical studies also have revealed the mediating effect of coping style on the relationships between dark personalities and negative outcomes. For instance, coping flexibility could mediate the relationship between narcissism and psychological health (Ng et al., 2014), and maladaptive coping styles could mediate the negative effects of secondary psychopathy on depression, anxiety and stress (Saltoğlu & Uysal Irak, 2020).

The mediating role of state boredom

State boredom refers to temporary aversive state of wanting and mainly originates from monotonous and repeated stimulus, and engagement deficiencies in activities (Eastwood et al., 2012; Miao & Xie, 2019). State boredom is mainly caused by two factors: external factors (including novel stimuli in the surrounding environment, the difficulty of tasks, and people's desire for novelty, excitement, and control) and internal factors (including intrinsic motivation, values and beliefs, and the ability to regulate and control, such as the ability of emotion introspection and emotion regulation (Eastwood et al., 2007; Gosline, 2007), and cognitive skills necessary to intrinsically generate interest

(Goldberg et al., 2011; Zhou et al., 2012). Researchers emphasized that the ability to cognitively generate interest or entertainment may be more effective in reducing boredom than adjusting the external environment to be more varied and stimulating (Polly et al., 1993). In the investigation of cognitive components associated with boredom, researchers found that the dogmatic cognitive style (individuals high in dogmatism are less receptive to novel stimuli (Smithers & Loble, 1978; Vacchiano et al., 1969) and think less clearly and efficiently (Plant et al., 1965)) decreased the perception of stimuli in the environment, which was likely to induce the boredom (Leong & Schneller, 1993). Accordingly, it is reasonable that one's coping style would also be related to boredom. Certain coping styles, such as negative coping involved avoidance and passivity, may reduce the likelihood of interactions with external world and further trigger the state boredom. The significant association between coping style and boredom has been evidenced (Yan et al., 2021). And another study showed that boredom proneness was negatively associated with effective emotion regulation strategies (Zhao et al., 2016).

In addition to the cognitive variables, the relationships between personality variables to boredom proneness were also evidenced. For example, Individuals who are less sociable, exhibit low levels of persistence, and experience many problems with inhibitory control of impulses are more prone to boredom (Leong & Schneller, 1993). And it has also been demonstrated dark traits were correlated with boredom (Ma et al., 2021). For example, Machiavellianism is positively associated with boredom (Lee, 2019; Oprea et al., 2019); psychopaths are prone to disinhibition and boredom susceptibility (Paulhus & Williams, 2002), which may be explained by their excitement-seeking tendencies (Hare, 1991); and narcissism (self-awareness creates personal evaluation and/or dwelling on the self (Seib & Vodanovich, 1998)) could also increase the likelihood of boredom (Eisnitz, 1974; Weinberger & Muller, 1974).

Regarding of the outcomes of boredom, evidence has shown that boredom could negatively influence individuals' mental health (Zhou et al., 2012). For instance, negative affect was reliably related to boredom (Raffaelli et al., 2018), and abundant literature has shown state boredom was positively correlated with stress, depression and anxiety (Chao et al., 2020; German & Latkin, 2012; Lee & Zelman, 2019; Sommers & Vodanovich, 2000; Yang et al., 2020).

The present study

The current study aimed to explore the relationships between Dark Triad and depression, anxiety and stress during the initial phase of COVID-19 among Chinese population and the sequential mediating effects of negative coping

Fig. 1 The hypothesized model

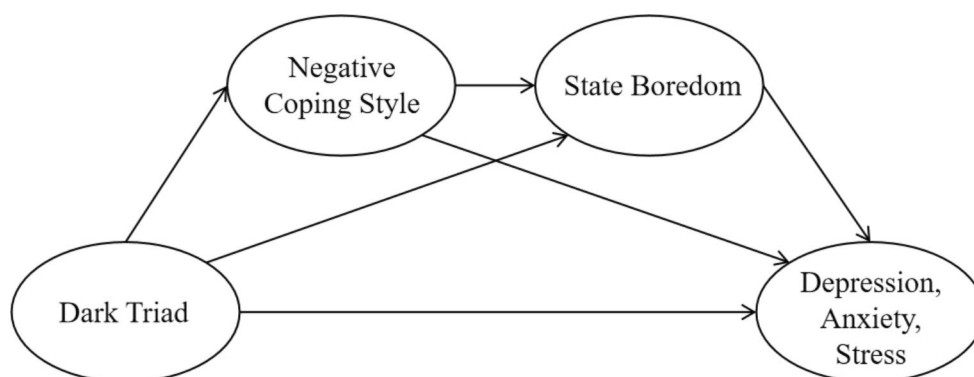

style and state boredom. Based on life history strategy theory, cognitive vulnerability-transactional stress model, and the literature aforementioned about the associations among the Dark Triad, negative coping style, boredom, and negative emotions, we hypothesized that present study provided three hypotheses: (1) Dark Triad would be positively associated with depression, anxiety, stress, negative coping style, and state boredom, (2) negative coping style would be also positively associated with state boredom, (3) negative coping style and state boredom would separately mediate and sequentially mediate the relationships between Dark Triad and depression, anxiety, and stress (Fig. 1). We attempted to provide suggestions about the prevention and intervention for mental problems during COVID-19 lockdown.

Method

Participants and procedures

A cross-sectional survey was conducted with convenience sampling to evaluate psychological responses of Chinese people during the period of strict COVID-19 quarantine (from 20th February, 2020 to 10th March, 2020). The study was conducted online to avoid face-to-face interactions and informed consents were obtained before survey. All procedures were coherent to the ethical standards of the institutional research committee and to the 1964 Helsinki declaration. A total of 464 participants aging from 14 to 71 years old ($M=37.68$, $SD=10.53$) were recruited in the study, and the sample consisted of 53.2% ($N=247$) female and 46.8% ($N=217$) male. In addition, the sample included 2.6% ($N=12$) healthcare worker, 6.1% ($N=28$) manager fighting against the epidemic, and 91.4% ($N=424$) general population.

Materials

Depression Anxiety and Stress Scale (DASS-21)

The DASS-21, the brief version of the Depression Anxiety Stress Scales-42, is a 21-item questionnaire validated in Chinese population to measure three negative emotions recently in the public domain with three subscales: depression, anxiety, and stress (Gong et al., 2010; Lovibond & Lovibond, 2002; Shah et al., 2021). Depression subscale is implemented to estimate anhedonia, inertia, self-deprecation and devaluation of life (e.g., *I felt that I had nothing to look forward to*). Anxiety subscale is used to measure autonomic arousal, situational anxiety, and experiences of anxiousness (e.g., *I felt scared without any good reason*). Stress subscale is employed to estimate persistent and non-specific arousal, difficulty of unwinding and mood changes (distress, irritability and impatience) (e.g., *I tended to overreact to situations*) (Lovibond & Lovibond, 2013). Items were rated on a 4-point Likert scale (0 = “did not apply to me”, 3 = “applied to me very much of the time”) and high subscale scores indicate high level of depression, anxiety, or stress. In this study, the Cronbach’s α were great for three subscales (depression: 0.91; anxiety: 0.90; stress: 0.88).

Short Dark Triad (SD3)

The SD3 is a 27-item questionnaire revised in China to evaluate maladaptive personality tendency (Geng et al., 2015; Paulhus & Jones, 2011) with three dimensions: Machiavellianism (e.g., *I like to use clever manipulation to get my way*), psychopathy (e.g., *I like to get revenge on authorities*), and narcissism (e.g., *People see me as a natural leader*). Items were rated on a 7-point Likert scale (1 = “strongly disagree”, 7 = “strongly agree”) and high SD3 scores indicate high level of Dark Triad. In this study, the Cronbach’s α was 0.84 for total scale, suggesting acceptable internal consistency reliability of SD3.

Table 1 Means (*M*), standard deviations (*SD*), and correlations between study variables (*N*=464)

	1	1a	1b	1c	2	3	4	5	6
1 DT	-								
1a mach	0.78***	-							
1b psych	0.75***	0.36***	-						
1c narci	0.73***	0.32***	0.38***	-					
2 NCS	0.29***	0.27***	0.26***	0.12**	-				
3 BO	0.34***	0.28***	0.37***	0.11*	0.41***	-			
4 DEP	0.35***	0.19**	0.48***	0.12**	0.38***	0.57***	-		
5 ANX	0.33***	0.16**	0.48***	0.12*	0.34***	0.54***	0.86***	-	
6 STR	0.37***	0.22***	0.49***	0.13**	0.40***	0.61***	0.86***	0.88***	-
<i>M</i>	63.35	25.44	15.43	22.49	17.79	81.12	10.03	10.17	11.25
<i>SD</i>	11.78	5.85	4.94	4.82	4.38	23.91	3.84	3.87	4.00

Note: DT = Dark Triad, mach = Machiavellianism, psych = Psychopathy, narci = Narcissism, NCS = Negative Coping Style, BO = State Boredom, DEP = depression, ANX = anxiety, STR = stress

* $p < 0.05$, ** $p < 0.01$, *** $p < 0.001$

Multidimensional State Boredom Scale (MSBS)

The MSBS is a 24-item questionnaire, revised and validated in Chinese population to assess state boredom recently (Fahlman et al., 2013; Liu et al., 2013) with five subscales: inattention (e.g., *I find it hard to focus my attention*), time perception (e.g., *Time passed very slowly*), low arousal (e.g., *I feel bored*), high arousal (e.g., *I feel anxious*), disengagement (e.g., *I had to do some things worthless to me*). Items were rated on a 7-point Likert scale (1 = “strongly disagree”, 7 = “strongly agree”) and high MSBS scores indicate more state boredom. In this study, the Cronbach’s α was 0.94 for total scale, suggesting great internal consistency reliability of MSBS.

Simplified Coping Style Questionnaire (SCSQ)

The SCSQ is a 20-item questionnaire, revised and validated in Chinese population (Xie, 1998), to assess regulatory function with two subscales: positive coping style (12 items; e.g., *I try to see things on the bright side*) and negative coping style (8 items; e.g., *I try to forget the whole thing*). Items were rated on a 4-point Likert scale (1 = “not use”, 4 = “always use”) and high subscale scores indicate high tendency of negative or positive coping style. In this study, only the subscale of negative coping style was used and the Cronbach’s α for this was 0.79, suggesting acceptable internal consistency reliability.

Data analyses

Preliminary analyses were performed via IBM SPSS (version 25). Zero-order Correlation were proceeded via Pearson Correlation and examination of common method biases was conducted via Harman’s one-factor test. Then, Structural Equation Modeling were conducted via Mplus (version 8.3)

with bootstrapping 1000 samples. In the SEM frame, latent Dark Triad was specified as independent variable, and latent variables for depression, anxiety and stress were specified as dependent variables. We investigated the indirect effects of negative coping style and state boredom in the relationships between Dark Triad and depression, anxiety and stress. Goodness of Model fit was obtained including Chi-Square (χ^2), Comparative Fit Index (CFI), Tucker-Lewis Index (TLI), SRMR (Standardized Root Mean Square Residual) and Root Mean Square Error of Approximation (RMSEA).

Results

Descriptive statistics

Analysis of common method biases indicated that 19 factors were extracted with eigenvalue more than one and accounted for 64.16% of total variance. The first factor explained 23.39% of variance, less than 40%, suggesting there was no serious common methodology deviation in the present study.

Results of Pearson Correlation were presented in Table 1. As expected, Dark Triad and its components were positively associated with depression, anxiety, and stress. Negative coping style and state boredom were both positively correlated with Dark Triad and its components, and depression, anxiety and stress. Additionally, negative coping style was positively correlated with boredom.

The sequential mediating role of negative coping style and state boredom

Structural Equation Modeling was conducted to explore the mediating role of negative coping style and boredom in the relationships between Dark Triad and depression, anxiety

Fig. 2 The mediating model for Dark Triad and depression. *Note:* DEP=depression, All path coefficients were standardized, same as below

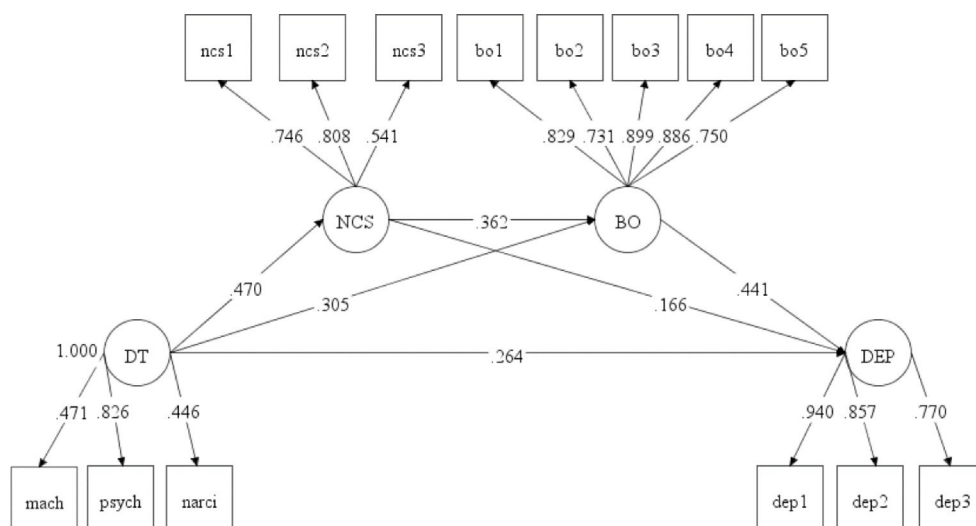

and stress. Study variables enrolled in the model were latent variables. Dark Triad was measured by three dimensions: Machiavellianism, psychopathy, and narcissism. Questionnaire of negative coping style is one-dimensional and homogenous, thus items were packaged through correlation method to get three indicators of negative coping style. Boredom was represented by five dimensions including inattention, time perception, low arousal, high arousal, and disengagement. Additionally, depression, anxiety and stress were separately packaged through correlation method to get three indicators.

Firstly, we tested the model regarding Dark Triad as independent variable, and depression as dependent variable. It was found that the model fit well ($\chi^2/df=3.679$, CFI=0.946, TLI=0.930, SRMR=0.051, RMSEA=0.076). As shown in Fig. 2, there was a significantly direct effect of Dark Triad on depression (effect=0.26, 95% CI [0.116, 0.386]), and three indirect effects of Dark Triad on depression including the mediating role of negative coping style (effect=0.08, $p=0.018$, 95% CI [0.019, 0.154]), mediating role of

boredom (effect=0.14, $p<0.001$, 95% CI [0.079, 0.209]), and sequential mediating role of negative coping style and boredom (effect=0.08, $p<0.001$, 95% CI [0.047, 0.124]). The 95% confidence intervals for these paths did not involve zero (Table 2), indicating mediating roles of negative coping style, boredom and chain mediating role of two mediators aforementioned in the relationship between Dark Triad and depression were significant. There was no significant difference in three indirect effects ($ps>0.05$). Additionally, the model accounted for 51.7% of variances in depression, suggesting the relationships proposed were informative.

Then the model of Dark Triad and anxiety was conducted and results were represented in Fig. 3. It was found that fitness of model was acceptable ($\chi^2/df=4.064$, CFI=0.937, TLI=0.919, SRMR=0.055, RMSEA=0.081). There was a significantly direct effect for Dark Triad on anxiety (effect=0.33, 95% CI [0.197, 0.468]), and two indirect effects for Dark Triad on anxiety including, including mediating role of boredom (effect=0.11, 95% CI [0.062, 0.172]), and sequential mediating role of negative coping

Fig. 3 The mediating model for Dark Triad and anxiety. *Note:* ANX = anxiety

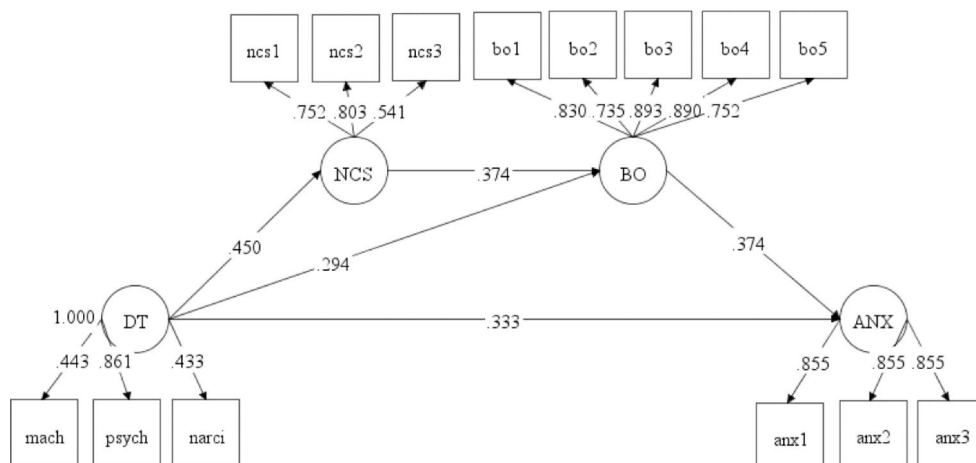

style and boredom (effect=0.06, 95% CI [0.039, 0.111]). Results indicated that the mediating role of boredom and chain mediating role of negative coping style and boredom in the relationship between Dark Triad and anxiety were significant. There was no significant difference in two indirect effects ($ps > 0.05$). However, the mediating role of negative coping style in the relationship aforementioned was not significant, since the 95% interval confidence concluded zero (Table 2). Additionally, the model accounted for 46.7% of variances in anxiety, suggesting the relationships proposed were informative.

Moreover, the model of Dark Triad and stress was conducted and results were represented in Fig. 4. The fitness of model was acceptable ($\chi^2/df=3.467$, CFI=0.948, TLI=0.934, SRMR=0.049, RMSEA=0.073). There was a significantly direct effect for Dark Triad on anxiety (effect=0.30, 95% CI [0.167, 0.431]), and three indirect effects for Dark Triad on anxiety including the mediating role of negative coping style (effect=0.07, 95% CI [0.007, 0.136]), mediating role of boredom (effect=0.15, 95% CI [0.089, 0.223]), and sequential mediating role of negative coping style and boredom (effect=0.08, 95% CI [0.052, 0.138]). The 95% confidence intervals for these paths did not involve zero (Table 2), indicating mediating roles of negative coping style, boredom and chain mediating role of both mediators aforementioned in the relationship between Dark Triad and depression were significant. There was no significant difference in three indirect effects ($ps > 0.05$). Additionally, the model accounted for 59.4% of variances in stress, suggesting the relationships proposed were informative.

Discussion

The present study offered fascinating perspectives in the relationships between Dark Triad and negative emotions during the initial phase of COVID-19 pandemic and strict

lockdown among Chinese population. Basically consistent with the hypotheses, results revealed that Dark Triad was positively correlated with depression, anxiety and stress, and negative coping style and state boredom separately and also sequentially mediated the relationships between Dark Triad and depression, anxiety and stress. The study provided new proofs to life history strategy theory and cognitive vulnerability-transactional stress model.

The current study showed during the COVID-19 quarantine and strict lockdown, Dark Triad and its three components were positively associated with depression, anxiety and stress among Chinese population. Present results about the positive relationships between Machiavellianism and narcissism and negative emotions were consistent with previous studies (Gogola et al., 2021; Lyons et al., 2019), which were also detected during COVID-19 pandemic. However, the present result about the positive associations between psychopathy, measured by SD3, and negative emotions was not accordant with previous studies (Mojsa-Kaja et al., 2021; Saltoğlu & Uysal Irak, 2020). The study conducted by Mojsa-Kaja et al. (2021) showed psychopathy, measured by Dirty Dozen (DD), was not significantly associated with stress and anxiety, and in the study of Saltoğlu and Uysal Irak (2020), primary psychopathy was not associated with anxiety and depression, but secondary psychopathy was significantly correlated with depression, anxiety and stress, which was consistent with the present result. The discrepancy may be attributed to the difference in the measurements of psychopathy. Because the DD is more likely to be used to measure the primary psychopathy, but the psychopathy subscale of SD3 emphasizes the impulsivity, rendering the psychopathy closer to secondary than to primary psychopathy (Hicks et al., 2007; Jones & Paulhus, 2014; Newman et al., 2005), whereas the psychopathy subscale of DD could assess callousness but fails to assess the impulsivity (Miller et al., 2012). That is, the secondary psychopathy was positively correlated with negative emotions, whereas

Fig. 4 The mediating model for Dark Triad and stress. Note: STR = stress

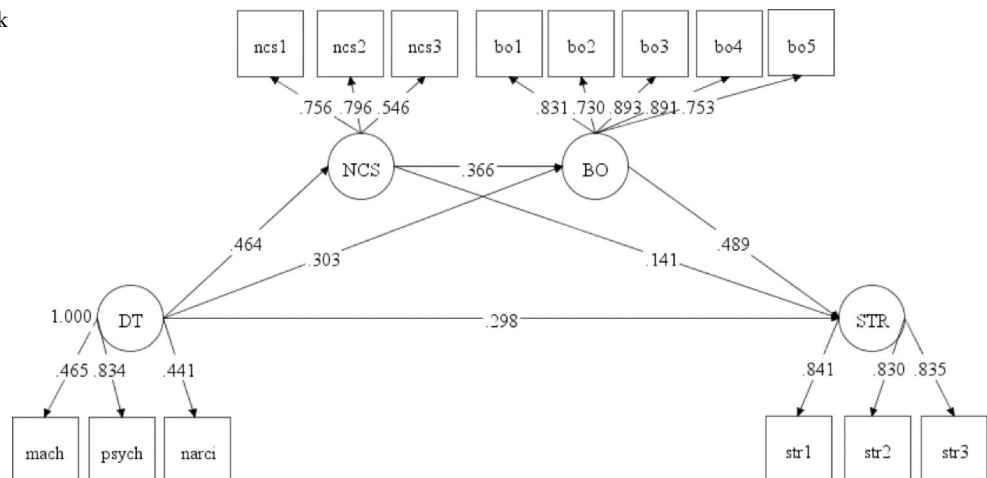

Table 2 Mediating effect analyses

	Effect	SE	<i>p</i>	95%CI
DV: Depression				
DT → NCS → Depression	0.08	0.03	0.018	[0.019, 0.154]
DT → BO → Depression	0.14	0.03	<0.001	[0.079, 0.209]
DT → NCS → BO → Depression	0.08	0.02	<0.001	[0.047, 0.124]
DV: Anxiety				
DT → NCS → Anxiety	0.06	0.03	0.083	[-0.003, 0.127]
DT → BO → Anxiety	0.11	0.03	<0.001	[0.062, 0.172]
DT → NCS → BO → Anxiety	0.06	0.02	<0.001	[0.039, 0.111]
DV: Stress				
DT → NCS → Stress	0.07	0.03	0.047	[0.007, 0.136]
DT → BO → Stress	0.15	0.03	<0.001	[0.089, 0.223]
DT → NCS → BO → Stress	0.08	0.02	<0.001	[0.052, 0.138]

Note: DV=Dependent Variable, DT=Dark Triad, NCS=Negative Coping Style, BO=State Boredom

the primary psychopathy was not robustly associated with negative emotions.

Besides, the mediating analyses showed the relationships between Dark Triad and negative emotions were partially mediated by negative coping style and state boredom, which indicated Dark Triad could not only directly predict negative emotions, but also indirectly predict them through negative coping style and state boredom. This could be interpreted by life history strategy theory (LHS). According to the theory, early-life experiences sensitized people to adversity (Birkás et al., 2020), thus individuals higher in Dark Triad, who possess fast life-history strategy caused by hard and unpredictable life in childhood and focus on immediate benefits at the expense of long-term relationship (Wilson et al., 1996) and mental well-being (Martin et al., 2012), could be relatively higher in depression, anxiety, and stress when confronted with the stressful COVID-19 pandemic and strict lockdown.

The positive relationship between Dark Triad and negative coping style revealed in the present study indicated individuals higher in Dark Triad did not focus on the stressor itself during the COVID-19 pandemic. The result was also consistent with previous studies. For example, Birkás and colleagues (2020) found Dark Triad could predict low coping ability, and Saltoğlu and Uysal Irak (2020) found that psychopathy was correlated with avoidance coping style, which also indicated people higher in the Dark Triad traits could not deal with the stressors well. Moreover, the present result was also supported by cognitive vulnerability-transactional stress model (Hankin & Abramson, 2001; Hankin et al., 2004) positing negative events and personality could stimulate individuals' negative vulnerability, i.e., mainly negative coping style and dysfunctional attitudes.

The positive relationship between Dark Triad and state boredom found in the current study indicated that individuals higher in Dark Triad were prone to boredom during the COVID-19 pandemic. The result was also supported by previous studies. For example, researchers have shown that Machiavellianism and psychopathy were positively correlated with boredom (Ma et al., 2021), and narcissism could also increase the likelihood of boredom (Eisnitz, 1974; Weinberger & Muller, 1974). The relationship between Dark Triad and state boredom may be explained by the dissatisfaction of the desire of individuals higher in Dark Triad for the novelty, excitement, and control during the COVID-19 pandemic and strict lockdown (Hare, 1991; Zhou et al., 2012), which could be confirmed by the finding that high boredom proneness was correlated with low control (Dahlen et al., 2004).

Consistent with the hypotheses, the results also showed the negative coping style and state boredom sequentially mediated the relationships between Dark Triad and depression, stress, and anxiety, and at the same time, the negative coping style mediated the relationships between Dark Triad and depression and stress, but not anxiety, and the state boredom mediated the relationships between Dark Triad and depression, stress, and anxiety. The results indicated that during COVID-19 pandemic and lockdown period, people high in Dark Triad were prone to use negative coping style including dealing with the external and internal stimuli negatively, which could enhance the levels of depression, anxiety and stress directly and indirectly by enhancing the level of state boredom which could also be positively influenced by the Dark Triad directly.

Firstly, findings regarding mediating role of negative coping style in the relationships between Dark Triad and negative emotions, indicating Dark Triad was a distal risk factor of negative emotions through the negative coping style. These provided new proofs to cognitive vulnerability-transactional stress model (Hankin & Abramson, 2001; Hankin et al., 2004). Negative events and personality stimulate individuals' negative vulnerability, i.e., mainly negative coping style and dysfunctional attitudes, which lead to increased negative emotions, such as boredom, depression, anxiety, and stress.

Additionally, the mediating effect of negative coping style revealed in the current study was consistent with the previous findings. For example, one prior study found that maladaptive cognitive emotion regulation strategies (i.e., rumination, catastrophizing, other-blame), which are also representatives of negative coping and focus on the negative aspect of the stressor, mediated the relationships between narcissism/Machiavellianism and depression, anxiety and stress (Mojsa-Kaja et al., 2021). In our study, the negative coping style contained taking rest, waiting for time and

fantasizing, which stressed the distraction from the stressor. The result also indicated that during the stressful COVID-19 pandemic, the distraction-related negative coping not only could induce the depression, stress and anxiety, but also enhance the level of state boredom. These two findings indicated that when confronted with stressful circumstances, individuals higher in Dark Triad tend to use negative coping including avoidant behaviors that are not focused on the stressor itself, which could induce the negative emotions. Besides, the finding by Mojsa-Kaja and colleagues (2021) indicated thinking about the negative aspect of the stressor could cause stress, anxiety and depression, and another finding that maladaptive coping behaviors including efforts to withdraw from the stressful situation and avoid seeking solutions may result in failure to resolve the stressful situation and be associated with anxiety (Mahmoud et al., 2012), both are supported by the present result.

However, in the mediation model for the anxiety, the path from negative coping style to anxiety was not significant, which indicated that after controlling the effects of Dark Triad and state boredom, there was no significant relationship between negative coping style and anxiety. The result was inconsistent with the findings by Mojsa-Kaja (2021) and Mahmoud (2012) who found the mediating effect of negative coping on the association between stressors and anxiety. The discrepancy may be interpreted by different predictors of anxiety used in the studies, and may be also explained by the effect of boredom on anxiety. But the current result was also consistent with some other previous studies. For example, in one review, the author argued that avoidance-oriented coping may be initially appropriate as a reaction to stress, but in the long run task-oriented coping is most efficacious (Endler, 1997). Another study showed that behavioral avoidance coping was unrelated to changes in anxious symptoms (Blalock & Joiner, 2000). All in all, the effect of coping style on anxiety needs to be explored further in the future studies.

More importantly, the present study showed the state boredom could mediate the effects of negative coping style on depression, anxiety and stress, which stimulated by the Dark Triad during the stressful COVID-19 pandemic. The result indicated that compared with Dark Triad and negative coping style, the state boredom was the more proximal vulnerable factor for the development of depression, anxiety and stress, which was consistent previous studies. For example, some researchers found boredom proneness mediated relationships between problematic smartphone use with depression and anxiety (Elhai et al., 2018), another study showed the effect of stressors on emotional distress (such as depression, fear, and compulsion-anxiety) was mediated by boredom proneness (Yan et al., 2021). Besides, as has been evidenced, state boredom could be caused by external

(such as novelty of stimuli, people's desire for novelty, excitement, and control) and internal factors (such as cognitive skills to intrinsically generate interest)(Goldberg et al., 2011; Zhou et al., 2012). In the present study, during the period of strict COVID-19 lockdown, almost all the people in China had to stay at home with no face-to-face interaction with other people. Thus individuals, especially higher in Dark Triad, had less likelihood to get the new things, which increased the dissatisfaction of their desire for novelty, excitement, and control, further leading to state boredom. Additionally, individuals who possess negative coping style (such as taking rest and waiting for time) caused by Dark Triad, tend to do nothing helpful to change the stressful and harsh circumstances repeatedly occurred during the strict COVID-19 lockdown, and then lead to the higher level of state boredom. Regarding with the reason why boredom influences negative emotions, Seib and Vodanovich (1998) have made a tentative explanation. They believed that individual's "self-awareness (an awareness of internal states, e.g., thoughts, emotions)" would directly lead to people's judgment and evaluation of their own emotions, and when the individuals are high in boredom, their "self-awareness" is relatively negative (i.e., focusing on deficiencies and faults), making themselves fall into the abyss of negative emotion (Seib & Vodanovich, 1998; Zhou et al., 2012).

Implications

The study revealed the relationships between Dark Triad and negative emotions and revealed how higher Dark Triad cause higher level of negative emotions from perspectives of negative coping style and state boredom during the initial period of strict COVID-19 quarantine in China. The present results had important implications for the prevention and intervention of depression, anxiety and stress during COVID-19 pandemic and lockdown. Specifically, the intervention strategies that focus on reducing Dark Triad, negative coping and boredom may help offset occurrence of negative emotional states.

The psychological counselors and therapists could work on cognitive vulnerability (i.e., negative coping style) of maladaptive population through Cognitive Behavior Therapy (CBT) to weaken the cognitive process from Dark Triad to negative emotions. Additionally, one previous study found that mindfulness could reduce boredom proneness (Yang et al., 2021), thus we suggest public to trial mindfulness practices to transfer attention to present moment and decrease state boredom, which could further decrease negative emotions. Furthermore, one longitudinal study found that intervention on agreeableness would drop the level of Dark Triad (Hudson, 2022), thus we also suggest individuals with maladaptive personality to participate in

intervention for agreeableness to decrease tendency of Dark Triad and further experience few negative emotions. These results may shed light on interventions for mental health-care and promote psychological health in public during post- COVID-19 Era.

Limitations and future directions

Several limitations of present study should be taken in consideration. Firstly, this study is cross-sectional, so the results should be interpreted with caution; Longitudinal and experimental designs are urgent to address this problem. Then, all data were gathered via self-report and online survey; Future studies can collect data from various informants. Tendency of Dark Triad was regarded as continuous variable in the current study, and future study could distinguish different levels of Dark Triad population and their difference in negative emotions could be represented by reaction time of individuals spending in decision-making behaviors. Moreover, the present study did not measure boredom proneness of participants as control variable, and subsequent study could take it into consideration to clarify the role of state boredom in the relationships between Dark Triad and negative emotions. Additionally, the current data were collected during the early stage of COVID-19 pandemic, future study could consider comparing the emotional states in different COVID-19 pandemic stages, such as early, middle, and post stages, and even after the pandemic.

Conclusion

Based on life history strategy theory and cognitive vulnerability-transactional stress model, the present study constituted a chain mediation model, and revealed the positive relationships between Dark Triad and negative emotions and the psychological mechanism beneath the relationships from the perspectives of negative coping style and state boredom, which offered an elaborate understanding of the relationships between Dark Triad and negative emotions during the period of COVID-19 strict lockdown in China. These findings provided new proofs to life history strategy theory and cognitive vulnerability-transactional stress model, and implications for individuals susceptible to mental problems and clinical psychological workers that reducing negative coping and boredom may have positive and effective impacts on reducing depression, anxiety, and stress during the period of COVID-19 pandemic and strict lockdown.

Funding This work was supported by 2020 Western Region/Local Cooperation Project of the China Scholarship Council (CSC) [Granted Number: 202008410388], Henan postdoctoral research start-up proj-

ect [grant number: 58], Henan Philosophy and Social Science Foundation [grant number: 2019CJY038], and Cultivation plan of excellent young scientific research team in Humanities and Social Sciences of Zhengzhou University [grant number: 6]. But the funding sources had no involvement in study design, in the collection, analysis and interpretation of data, in the writing of the report, and in the decision to submit the article for publication.

Data Availability The datasets generated during and/or analyzed during the current study are available from the corresponding author on reasonable request.

Declarations

Interest declarations The authors declares that there is no conflict of interest.

Ethical approval All procedures performed in the study were in accordance with the ethical standards of the Research Ethical Committee in Zhengzhou University (Reference Number: 126), and with the 1964 Helsinki declaration and its later amendments or comparable ethical standards.

Informed consent Informed consent was obtained from all individual participants included in the study.

References

- Altshuler, J. L., & Ruble, D. N. (1989). Developmental changes in children's awareness of strategies for coping with uncontrollable stress. *Child Development, 60*(6), 1337-1349. <https://doi.org/10.2307/1130925>
- Alvaro, P. K., Roberts, R. M., & Harris, J. K. (2013). A systematic review assessing bidirectionality between sleep disturbances, anxiety, and depression. *Sleep, 36*(7), 1059-1068. <https://doi.org/10.5665/sleep.2810>
- Anyan, F., & Hjemdal, O. (2016). Adolescent stress and symptoms of anxiety and depression: Resilience explains and differentiates the relationships. *Journal of Affective Disorders, 203*, 213-220. <https://doi.org/10.1016/j.jad.2016.05.031>
- Berman, S. L., Kurtines, W. M., Silverman, W. K., & Serafini, L. T. (1996). The impact of exposure to crime and violence on urban youth. *American Journal of Orthopsychiatry, 66*(3), 329-336. <https://doi.org/10.1037/h0080183>
- Birkás, B., Pátkai, G., & Csathó, Á. (2020). The mediating role of the Dark Triad between life history strategy and perceived stress factors. *Psychological Reports, 123*(2), 252-265. <https://doi.org/10.1177/0033294118818095>
- Blalock, J. A., & Joiner, T. E. (2000). Interaction of cognitive avoidance coping and stress in predicting depression/anxiety. *Cognitive Therapy and Research, 24*(1), 47-65. <https://doi.org/10.1023/A:1005450908245>
- Carter, G. L., Campbell, A. C., & Muncer, S. (2014). The Dark Triad personality: Attractiveness to women. *Personality and Individual Differences, 56*, 57-61. <https://doi.org/10.1016/j.paid.2013.08.021>
- Chao, M., Chen, X., Liu, T., Yang, H., & Hall, B. J. (2020). Psychological distress and state boredom during the COVID-19 outbreak in China: The role of meaning in life and media use. *European Journal of Psychotraumatology, 11*(1), 1769379. <https://doi.org/10.1080/20008198.2020.1769379>
- Dahlen, E. R., Martin, R. C., Ragan, K., & Kuhlman, M. M. (2004). Boredom proneness in anger and aggression: Effects

- of impulsiveness and sensation seeking. *Personality and Individual Differences*, 37(8), 1615-1627. <https://doi.org/10.1016/j.paid.2004.02.016>
- Dempsey, M. (2002). Negative coping as mediator in the relation between violence and outcomes: Inner-city African American youth. *American Journal of Orthopsychiatry*, 72(1), 102-109. <https://doi.org/10.1037/0002-9432.72.1.102>
- Eastwood, J. D., Cavaliere, C., Fahlman, S. A., & Eastwood, A. E. (2007). A desire for desires: Boredom and its relation to alexithymia. *Personality and Individual Differences*, 42(6), 1035-1045. <https://doi.org/10.1016/j.paid.2006.08.027>
- Eastwood, J. D., Frischen, A., Fenske, M. J., & Smilek, D. (2012). The unengaged mind: Defining boredom in terms of attention. *Perspectives on Psychological Science*, 7(5), 482-495. <https://doi.org/10.1177/1745691612456044>
- Eisnitz, A. J. (1974). A discussion of the paper by J. L. Weinberger and J. J. Muller on 'The American Icarus Revisited: Phallic narcissism and boredom'. *International Journal of Psychoanalysis*, 55, 587-590.
- Elhai, J. D., Vasquez, J. K., Lustgarten, S. D., Levine, J. C., & Hall, B. J. (2018). Proneness to boredom mediates relationships between problematic smartphone use with depression and anxiety severity. *Social Science Computer Review*, 36(6), 707-720. <https://doi.org/10.1177/0894439317741087>
- Ellis, B. J., Figueredo, A. J., Brumbach, B. H., & Schlomer, G. L. (2009). Fundamental dimensions of environmental risk. *Human Nature*, 20(2), 204-268. <https://doi.org/10.1007/s12110-009-9063-7>
- Endler, N. S. (1997). Stress, anxiety and coping: The multidimensional interaction model. *Canadian Psychology/Psychologie canadienne*, 38(3), 136-153. <https://doi.org/10.1037/0708-5591.38.3.136>
- Fahlman, S. A., Mercer-Lynn, K. B., Flora, D. B., & Eastwood, J. D. (2013). Development and validation of the multidimensional state boredom scale. *Assessment*, 20(1), 68-85. <https://doi.org/10.1177/10731911111421303>
- Frison, E., & Eggermont, S. (2016). Exploring the relationships between different types of Facebook use, perceived online social support, and adolescents' depressed mood. *Social Science Computer Review*, 34(2), 153-171. <https://doi.org/10.1177/0894439314567449>
- Furnham, A., Richards, S., Rangel, L., & Jones, D. N. (2014). Measuring malevolence: Quantitative issues surrounding the Dark Triad of personality. *Personality and Individual Differences*, 67, 114-121. <https://doi.org/10.1016/j.paid.2014.02.001>
- Furnham, A., Richards, S. C., & Paulhus, D. L. (2013). The Dark Triad of personality: A 10 year review. *Social and Personality Psychology Compass*, 7(3), 199-216. <https://doi.org/10.1111/spc3.12018>
- Geng, Y., Gu, J., Zhu, X., Yang, M., Shi, D., Shang, J., & Zhao, F. (2020). Negative emotions and quality of life among adolescents: A moderated mediation model. *International Journal Clinical and Health Psychology*, 20(2), 118-125. <https://doi.org/10.1016/j.ijchp.2020.02.001>
- Geng, Y., Sun, Q., Huang, J., Zhu, Y., & Han, X. (2015). Dirty Dozen and Short Dark Triad: A Chinese validation of two brief measures of the Dark Triad. *Chinese Journal of Clinical Psychology*, 23. <https://doi.org/10.16128/j.cnki.1005-3611.2015.02.013>
- Gogola, A. M., Dębski, P., Goryczka, A., Goryczyca, P., & Piegza, M. (2021). The Dark Triad of personality's relationship with compliance towards COVID-19 pandemic recommendations along with anxiety and depressive symptoms in Polish citizens. *International Journal of Environmental Research and Public Health*, 18(10). <https://doi.org/10.3390/ijerph18105478>
- Goldberg, Y. K., Eastwood, J. D., Laguardia, J., & Danckert, J. (2011). Boredom: An emotional experience distinct from apathy, anhedonia, or depression. *Journal of Social and Clinical Psychology*, 30(6), 647-666. <https://doi.org/10.1521/jscp.2011.30.6.647>
- Gómez-Leal, R., Megías-Robles, A., Gutiérrez-Cobo, M. J., Cabello, R., Fernández-Abascal, E. G., & Fernández-Berrocal, P. (2019). Relationship between the Dark Triad and depressive symptoms. *PeerJ*, 7, e8120. <https://doi.org/10.7717/peerj.8120>
- Gong, X., Xie, X., Xu, R., & Luo, Y. (2010). Psychometric properties of the Chinese versions of DASS-21 in Chinese college students. *Chinese Journal of Clinical Psychology*, 18. <https://doi.org/10.16128/j.cnki.1005-3611.2010.04.020>
- Gosline, A. (2007). Bored? *Scientific American Mind*, 18(6), 20-27.
- Hankin, B. L., & Abramson, L. Y. (2001). Development of gender differences in depression: An elaborated cognitive vulnerability-transactional stress theory. *Psychological Bulletin*, 127(6), 773-796. <https://doi.org/10.1037/0033-2909.127.6.773>
- Hankin, B. L., Abramson, L. Y., Miller, N., & Haeffel, G. J. (2004). Cognitive vulnerability-stress theories of depression: Examining affective specificity in the prediction of depression versus anxiety in three prospective studies. *Cognitive Therapy and Research*, 28(3), 309-345. <https://doi.org/10.1023/B:COTR.0000031805.60529.0d>
- Hare, R. D. (1991). Manual for the revised psychopathy checklist (1st ed.). *Multi-Health Systems*.
- Henry, J. D., & Crawford, J. R. (2005). The short-form version of the Depression Anxiety Stress Scales (DASS-21): Construct validity and normative data in a large non-clinical sample. *British Journal of Clinical Psychology*, 44(Pt 2), 227-239. <https://doi.org/10.1348/014466505x29657>
- Hicks, B., Blonigen, D., Kramer, M., Krueger, R., Patrick, C., Iacono, W., & McGue, M. (2007). Gender differences and developmental change in externalizing disorders from late adolescence to early adulthood: A longitudinal twin study. *Journal of Abnormal Psychology*, 116, 433-447. <https://doi.org/10.1037/0021-843X.116.3.433>
- Hou, F., Bi, F., Jiao, R., Luo, D., & Song, K. (2020). Gender differences of depression and anxiety among social media users during the COVID-19 outbreak in China: A cross-sectional study. *Bmc Public Health*, 20(1), 1648. <https://doi.org/10.1186/s12889-020-09738-7>
- Hudson, N. (2022). Lighten the darkness: Personality interventions targeting agreeableness also reduce participants' levels of the Dark Triad. *Journal of Personality*. <https://doi.org/10.1111/jopy.12714>
- Jonason, P. K., Koenig, B. L., & Tost, J. (2010). Living a fast life. *Human Nature*, 21(4), 428-442. <https://doi.org/10.1007/s12110-010-9102-4>
- Jones, D. N., & Paulhus, D. L. (2014). Introducing the short Dark Triad (SD3): A brief measure of dark personality traits. *Assessment*, 21(1), 28-41. <https://doi.org/10.1177/1073191113514105>
- Lai, J., Ma, S., Wang, Y., Cai, Z., Hu, J., Wei, N., Wu, J., Du, H., Chen, T., & Li, R. (2020). Factors associated with mental health outcomes among health care workers exposed to coronavirus disease 2019. *JAMA Network Open*, 3(3), e203976. <https://doi.org/10.1001/jamanetworkopen.2020.3976>
- Lazarus, R. S., & Folkman, S. (1987). Transactional theory and research on emotions and coping. *European Journal of Personality*, 1(3), 141-169. <https://doi.org/10.1002/per.2410010304>
- Lee, F. K. S., & Zelman, D. C. (2019). Boredom proneness as a predictor of depression, anxiety and stress: The moderating effects of dispositional mindfulness. *Personality and Individual Differences*, 146, 68-75. <https://doi.org/10.1016/j.paid.2019.04.001>
- Lee, S. A. (2019). The Dark Tetrad and callous reactions to mourner grief: Patterns of annoyance, boredom, entitlement, schadenfreude, and humor. *Personality and Individual Differences*, 137, 97-100. <https://doi.org/10.1016/j.paid.2018.08.019>
- Leong, F. T. L., & Schneller, G. R. (1993). Boredom proneness: Temperamental and cognitive components. *Personality and Individual Differences*, 14(1), 233-239. [https://doi.org/10.1016/0191-8869\(93\)90193-7](https://doi.org/10.1016/0191-8869(93)90193-7)

- Lewis-Fernández, R., & Kleinman, A. (1994). Culture, personality, and psychopathology. *Journal of Abnormal Psychology, 103*(1), 67. <https://doi.org/10.1037//0021-843x.103.1.67>
- Liu, Y., Chen, J., Jiang, M., Xu, H., & Eastwood, J. D. (2013). The Chinese version of the Multidimensional State Boredom Scale (MSBS): Its applicability in Chinese college students. *Chinese Journal of Clinical Psychology, 21*(4), 558-557. <https://doi.org/10.16128/j.cnki.1005-3611.2013.04.012>
- Lovibond, S. H., & Lovibond, P. F. (2002). Manual for the Depression Anxiety Stress Scales.
- Lovibond, S. H., & Lovibond, P. F. (2013). Depression Anxiety and Stress Scales (DASS).
- Lyons, M., Evans, K., & Helle, S. (2019). Do “dark” personality features buffer against adversity? The associations between cumulative life stress, the Dark Triad, and mental distress. *SAGE Open, 9*(1), 2158244018822383. <https://doi.org/10.1177/2158244018822383>
- Ma, G. X., Born, M. P., Petrou, P., & Bakker, A. B. (2021). Bright sides of dark personality? A cross-cultural study on the dark triad and work outcomes. *International Journal of Selection and Assessment, 29*, 510-518. <https://doi.org/10.1111/ijsa.12342>
- Mahmoud, J. S., Staten, R., Hall, L. A., & Lennie, T. A. (2012). The relationship among young adult college students’ depression, anxiety, stress, demographics, life satisfaction, and coping styles. *Issues In Mental Health Nursing, 33*(3), 149-156. <https://doi.org/10.3109/01612840.2011.632708>
- Martin, R. A., Lastuk, J. M., Jeffery, J., Vernon, P. A., & Veselka, L. (2012). Relationships between the Dark Triad and humor styles: A replication and extension. *Personality and Individual Differences, 52*(2), 178-182. <https://doi.org/10.1016/j.paid.2011.10.010>
- McDonald, M. M., Donnellan, M. B., & Navarrete, C. D. (2012). A life history approach to understanding the Dark Triad. *Personality and Individual Differences, 52*(5), 601-605. <https://doi.org/10.1016/j.paid.2011.12.003>
- Miao, P., & Xie, X. F. (2019). State boredom: An emotion that seeks to change. *Acta Scientiarum Naturalium Universitatis Pekinensis, 55*(6), 1161-1169. <https://doi.org/10.13209/j.0479-8023.2019.083>
- Miller, J. D., Few, L. R., Seibert, L. A., Watts, A., Zeichner, A., & Lynam, D. R. (2012). An examination of the Dirty Dozen measure of psychopathy: A cautionary tale about the costs of brief measures. *Psychological Assessment, 24*(4), 1048-1053. <https://doi.org/10.1037/a0028583>
- Mojsa-Kaja, J., Szklarczyk, K., González-Yubero, S., & Palomera, R. (2021). Cognitive emotion regulation strategies mediate the relationships between Dark Triad traits and negative emotional states experienced during the COVID-19 pandemic. *Personality and Individual Differences, 181*, 111018. <https://doi.org/10.1016/j.paid.2021.111018>
- Nagase, Y., Uchiyama, M., Kaneita, Y., Li, L., Kaji, T., Takahashi, S., Konno, M., Mishima, K., Nishikawa, T., & Ohida, T. (2009). Coping strategies and their correlates with depression in the Japanese general population. *Psychiatry Research, 168*(1), 57-66. <https://doi.org/10.1016/j.psychres.2008.03.024>
- Neufeld, R. W. J. (1989). Advances in the investigation of psychological stress. Edited by R. W. Neufeld. Wiley Interscience, New York, 1989. No. of pages: 453. Price: £39.30. *Stress Medicine, 7*(2), 133-133. <https://doi.org/10.1002/smi.2460070215>
- Newman, J., MacCoon, D., Vaughn, L., & Sadeh, N. (2005). Validating a distinction between primary and secondary psychopathy with measures of Gray’s BIS and BAS constructs. *Journal of Abnormal Psychology, 114*, 319-323. <https://doi.org/10.1037/0021-843X.114.2.319>
- Oprea, B., Ilescu, D., Burtăverde, V., & Dumitrache, M. (2019). Personality and boredom at work: The mediating role of job crafting. *Career Development International, ahead-of-print*. <https://doi.org/10.1108/cdi-08-2018-0212>
- Paulhus, D., & Jones, D. (2011). Introducing a short measure of the Dark Triad. *Poster Presented at the Meeting of the Society for Personality and Social Psychology, San Antonio*.
- Paulhus, D. L., & Williams, K. M. (2002). The Dark Triad of personality: Narcissism, Machiavellianism, and psychopathy. *Journal of Research in Personality, 36*(6), 556-563. [https://doi.org/10.1016/S0092-6566\(02\)00505-6](https://doi.org/10.1016/S0092-6566(02)00505-6)
- Plant, W. T., Telford, C. W., & Thomas, J. A. (1965). Some personality differences between dogmatic and nondogmatic groups. *Journal Of Social Psychology, 67*(1), 67-75. <https://doi.org/10.1080/00224545.1965.9922259>
- Polly, L. M., Vodanovich, S. J., Watt, J. D., & Blanchard, M. J. (1993). The effects of attributional processes on boredom proneness. *Journal of Social Behavior and Personality, 8*(1), 123.
- Raffaelli, Q., Mills, C., & Christoff, K. (2018). The knowns and unknowns of boredom: A review of the literature. *Experimental Brain Research, 236*(9), 2451-2462. <https://doi.org/10.1007/s00221-017-4922-7>
- Rahafar, A., Randler, C., Castellana, I., & Kausch, I. (2017). How does chronotype mediate gender effect on Dark Triad? *Personality and Individual Differences, 108*, 35-39. <https://doi.org/10.1016/j.paid.2016.12.002>
- Rauthmann, J. F., & Kolar, G. P. (2013). The perceived attractiveness and traits of the Dark Triad: Narcissists are perceived as hot, Machiavellians and psychopaths not. *Personality and Individual Differences, 54*(5), 582-586. <https://doi.org/10.1016/j.paid.2012.11.005>
- Rim, Y. (1992). Machiavellianism and coping styles. *Personality and Individual Differences, 13*(4), 487-489. [https://doi.org/10.1016/0191-8869\(92\)90079-5](https://doi.org/10.1016/0191-8869(92)90079-5)
- Rushton, J. P. (1985). Differential K theory and race differences in E and N. *Personality and Individual Differences, 6*(6), 769-770. [https://doi.org/10.1016/0191-8869\(85\)90088-1](https://doi.org/10.1016/0191-8869(85)90088-1)
- Saltoğlu, S., & Uysal Irak, D. (2020). Primary versus secondary psychopathy: Coping styles as a mediator between psychopathy and well-being. *Current Psychology, https://doi.org/10.1007/s12144-020-01155-8*
- Seib, H. M., & Vodanovich, S. J. (1998). Cognitive correlates of boredom proneness: The role of private self-consciousness and absorption. *Journal of Psychology, 132*(6), 642-652. <https://doi.org/10.1080/00223989809599295>
- Shah, S. M. A., Mohammad, D., Qureshi, M. F. H., Abbas, M. Z., & Aleem, S. (2021). Prevalence, psychological responses and associated correlates of depression, anxiety and stress in a global population, during the Coronavirus Disease (COVID-19) pandemic. *Community Mental Health Journal, 57*(1), 101-110. <https://doi.org/10.1007/s10597-020-00728-y>
- Shao, R., He, P., Ling, B., Tan, L., Xu, L., Hou, Y., Kong, L., & Yang, Y. (2020). Prevalence of depression and anxiety and correlations between depression, anxiety, family functioning, social support and coping styles among Chinese medical students. *BMC Psychology, 8*(1), 38. <https://doi.org/10.1186/s40359-020-00402-8>
- Smithers, A. G., & Lobley, D. M. (1978). Dogmatism, social attitudes and personality. *British Journal of Social & Clinical Psychology, 17*(2), 135-142. <https://doi.org/10.1111/j.2044-8260.1978.tb00255.x>
- Sommers, J., & Vodanovich, S. J. (2000). Boredom proneness: Its relationship to psychological- and physical-health symptoms. *Journal of Clinical Psychology, 56*, 149-155. [https://doi.org/10.1002/\(sici\)1097-4679\(200001\)56:13.0.co;2-y](https://doi.org/10.1002/(sici)1097-4679(200001)56:13.0.co;2-y)
- Truhan, T. E., Gianniou, F. M., & Papageorgiou, K. A. (2022). Differences in psychiatric symptoms between the UK and Greece prior to and during COVID-19: The roles of subclinical narcissism and mental toughness. *Personality and Individual Differences, 185*, 111308. <https://doi.org/10.1016/j.paid.2021.111308>

- Vacchiano, R. B., Strauss, P. S., & Hochman, L. (1969). The open and closed mind: A review of dogmatism. *Psychological Bulletin*, 71(4), 261-273. <https://doi.org/10.1037/h0027056>
- Wang, C., Pan, R., Wan, X., Tan, Y., Xu, L., Ho, C. S., & Ho, R. C. (2020). Immediate psychological responses and associated factors during the initial stage of the 2019 Coronavirus Disease (COVID-19) epidemic among the general population in China. *International Journal of Environmental Research and Public Health*, 17(5), <https://doi.org/10.3390/ijerph17051729>
- Weinberger, J. L., & Muller, J. J. (1974). The American Icarus revisited: Phallic narcissism and boredom. *International Journal of Psychoanalysis*, 55(4), 581-590.
- Wilson, D. S., Near, D., & Miller, R. R. (1996). Machiavellianism: A synthesis of the evolutionary and psychological literatures. *Psychological Bulletin*, 119(2), 285. <https://doi.org/10.1037/0033-2909.119.2.285>
- Xiao, X., Zhu, X., Fu, S., Hu, Y., Li, X., & Xiao, J. (2020). Psychological impact of healthcare workers in China during COVID-19 pneumonia epidemic: A multi-center cross-sectional survey investigation. *Journal Of Affective Disorders*, 274, 405-410. <https://doi.org/10.1016/j.jad.2020.05.081>
- Xie, Y. (1998). The preliminary study on reliability and variability of simplified coping style questionnaire. *Chinese Journal of Clinical Psychology*, 6, 114-115.
- Yan, L., Gan, Y., Ding, X., Wu, J., & Duan, H. (2021). The relationship between perceived stress and emotional distress during the COVID-19 outbreak: Effects of boredom proneness and coping style. *Journal of Anxiety Disorders*, 77, 102328. <https://doi.org/10.1016/j.janxdis.2020.102328>
- Yang, M., Zhu, X., Sai, X., Zhao, F., Wu, H., & Geng, Y. (2019). The Dark Triad and sleep quality: Mediating role of anger rumination. *Personality and Individual Differences*, 151, 109484. <https://doi.org/10.1016/j.paid.2019.06.027>
- Yang, X. J., Fan, C. Y., Zhou, Z. K., Liu, Q. Q., & Lian, S. L. (2021). The relationship between mindfulness and mobile phone addiction tendency: The roles of boredom proneness and future time perspective. *Psychological Development and Education*, 37(3), 419-428. <https://doi.org/10.16187/j.cnki.issn1001-4918.2021.03.13>
- Yang, X. J., Liu, Q. Q., Lian, S. L., & Zhou, Z. K. (2020). Are bored minds more likely to be addicted? The relationship between boredom proneness and problematic mobile phone use. *Addictive Behaviors*, 108, 106426. <https://doi.org/10.1016/j.addbeh.2020.106426>
- Zhang, Y., Huang, L., Luo, Y., & Ai, H. (2021). The relationship between state loneliness and depression among youths during COVID-19 lockdown: Coping style as mediator. *Frontiers in Psychology*, 12, 701514. <https://doi.org/10.3389/fpsyg.2021.701514>
- Zhao, X., Li, Y. Y., Jin, J., & Jin, G. (2016). Boring tendency and learning burnout: The mediating effect of emotion regulation strategies. *Chinese Journal of Clinical Psychology*, 24(01), 64-68. <https://doi.org/10.16128/j.cnki.1005-3611.2016.01.015>
- Zhou, H., Wang, Q., & Dong, Y. (2012). Boredom: A long and revival research topic. *Advances in Psychological Science*, 20(1), 98-107. https://journal.psych.ac.cn/xlxkjz/CN/abstract/article_1163.shtml
- Birkás, B., Gács, B., & Csathó, Á. (2016). Keep calm and don't worry: Different Dark Triad traits predict distinct coping preferences. *Personality and Individual Differences*, 88, 134-138. <https://doi.org/10.1016/j.paid.2015.09.007>
- German, D., & Latkin, C. A. (2012). Boredom, depressive symptoms, and HIV risk behaviors among urban injection drug users. *AIDS and Behavior*, 16(8), 2244-2250. <https://doi.org/10.1007/s10461-012-0247-5>

Publisher's Note Springer Nature remains neutral with regard to jurisdictional claims in published maps and institutional affiliations.

Springer Nature or its licensor holds exclusive rights to this article under a publishing agreement with the author(s) or other rightsholder(s); author self-archiving of the accepted manuscript version of this article is solely governed by the terms of such publishing agreement and applicable law.