

# Study on the Influencing Factors of Knowledge, Attitudes and Practice About Tuberculosis Among Freshmen in Jiangsu, China: A Cross-Sectional Study

Guoping Du<sup>1,\*</sup>, Chao Li<sup>2,\*</sup>, Yangyang Liu<sup>3,\*</sup>, Fulai Tu<sup>3</sup>, Ruizhe Yang<sup>4</sup>, Rui Li<sup>3</sup>, Hongbing Shen<sup>2</sup>, Wei Li<sup>5</sup>

<sup>1</sup>Department of General Practice, Southeast University Hospital, Nanjing, Jiangsu, People's Republic of China; <sup>2</sup>Department of Epidemiology, Center for Global Health, School of Public Health, Nanjing Medical University, Nanjing, Jiangsu, People's Republic of China; <sup>3</sup>Key Laboratory of Environmental Medicine Engineering, Department of Epidemiology and Health Statistics, School of Public Health, Southeast University, Nanjing, Jiangsu, People's Republic of China; <sup>4</sup>Department of Prevention and Health Care, Children's Hospital of Nanjing Medical University, Nanjing, Jiangsu, People's Republic of China; <sup>5</sup>Department of Quality Management, Children's Hospital of Nanjing Medical University, Nanjing, Jiangsu, People's Republic of China

\*These authors contributed equally to this work

Correspondence: Wei Li, Department of Quality Management, Children's Hospital of Nanjing Medical University, Nanjing, Jiangsu, People's Republic of China, Tel/Fax +86 025 52862911, Email weil126@126.com; Hongbing Shen, Department of Epidemiology, Center for Global Health, School of Public Health, Nanjing Medical University, Nanjing, Jiangsu, People's Republic of China, Tel/Fax +86 025 86868409, Email hbshen@njmu.edu.cn

**Background:** Adolescents aged from 19 to 22 are the main high-risk population of pulmonary tuberculosis (PTB). This study aimed to understand the current status of knowledge, attitudes and practices (KAP) about TB among freshmen from Jiangsu colleges and universities. Analyze its influencing factors and explore the interrelationships of KAP. This provides a basis for building a reversing mechanism for health education on tuberculosis prevention and treatment in middle and high schools.

**Methods:** A multistage randomly was used to select freshmen to conduct this online survey. The  $\chi^2$  test was used to compare the rates. Construct linear regression model, logistic regression model, decision tree model and random forest model, use grid search to adjust the parameters of the model, and use multiple models to explore the influencing factors of the overall awareness rate of students' core knowledge of tuberculosis.

**Results:** A total of 6980 freshmen in colleges and universities were investigated. The total awareness rate was 89.02%, and the awareness rate of all core knowledge about TB was 58.94%. It is characterized by general demographic data, and all core knowledge is known as a label to establish a model, based on the f1- of the four models The score believes that the random forest model has the best fitting effect, and the ranking of the influencing factors included in the model is school type (0.72) >father's education (0.15) >family monthly income (0.03) >mother's education, gender, region (0.02); a structural equation model is established, and the modified knowledge and attitude path coefficient is 0.29 ( $P<0.05$ ); the attitude and behavior path coefficient is 0.64 ( $P<0.05$ ).

**Conclusion:** The total awareness rate of core knowledge of Jiangsu college freshmen reaches the national requirements, but the overall awareness rate is low. It is necessary to strengthen the health education of tuberculosis for those with identified risk factors.

**Keywords:** knowledge, attitudes and practices, tuberculosis, freshmen

## Background

PTB is a kind of disease that caused tuberculous pathological changes of the respiratory system by mycobacterium tuberculosis infection.<sup>1</sup> According to Global Tuberculosis Report 2020, China is still a high-burden country of PTB.<sup>2</sup> Additionally, due to the outbreak of COVID-19 by the end of 2019, TB notification and follow-up examinations in China were affected, Prevention and control progress of PTB had been severely disrupted.<sup>3</sup> A prevalent trend may recover in the future. Currently, the number of new PTB cases in China ranks No.3 around the world,<sup>4</sup> as well as the epidemic situation, remains serious. However, adolescents aged from 19 to 22 are the main high-risk population of PTB, which most are college

and university students.<sup>5</sup> Delay for seeking medical advice is ubiquity among this population.<sup>6,7</sup> To a certain extent, lack of knowledge about tuberculosis prevention leads to failure to discover and treat during the early stage.<sup>8,9</sup> Secondly, these students are usually live in a large population density environment with remarkable characteristics, for instance, significant mobility, group living, poor nutritional status and lack of awareness about TB.<sup>10</sup> It's easy to cause PTB to spread in colleges or universities if there are cases of open tuberculosis, and the risk of active TB increased in college students.<sup>11</sup> It is necessary to highlight for understanding more deeply on the University students' knowledge, awareness, and perception towards TB diseases.

Based on the above background, this study investigated the cognition, attitude and behavior of tuberculosis prevention and control among freshmen in colleges and universities in Jiangsu Province, we also analyzed factors affecting the overall awareness rate of core knowledge about tuberculosis and explore the relationship between tuberculosis prevention knowledge, attitudes and behaviors. To provide the basis for optimizing tuberculosis prevention and control work in colleges and universities.

## Methods

### Ethics Approval and Consent to Participate

This study was reviewed and approved by the Human Research Ethics Committee of the Zhongda hospital affiliated Southeast University, China (approval ID: 2017ZDKYSB045). All participating subjects received written detailed information on the study, and signed consent forms for the interview and the processing of sensitive personal data, if participants under 18 years of age parental informed consent was obtained. The procedure of the study was performed in accordance with the guidelines outlined in the Declaration of Helsinki.

### Subject

Jiangsu is an eastern-central coastal province of the People's Republic of China. It is one of the leading provinces in finance, education, technology, and tourism. As of 2020 Jiangsu hosts 159 institutions of higher education, ranking first of all Chinese provinces. We used stratified random sampling, 12 undergraduate universities and 5 colleges were randomly selected from southern, central and northern Jiangsu, and about 10 to 13 freshman classes were randomly selected from selected samples, 16 to 18 male and female students who registered in Jiangsu Province as permanent residents in these classes were randomly selected as research subjects. Totally 7173 subjects were investigated in this study.

### Questionnaire

The questionnaire, which was designed based on "2006 National Questionnaire of Tuberculosis Prevention and Control Knowledge, Beliefs, and Behaviors in Public", was reviewed and revised by experts and the literature search investigation team (Table S1). The content of the questionnaire includes 1) basic demographic characteristics: gender, age, ethnicity, region, etc.; 2) 7 single-choice questions about core knowledge of tuberculosis prevention and control; 3) 7 questions about tuberculosis prevention and treatment attitudes and behaviors. The Cronbach's  $\alpha$  coefficient of this questionnaire is 0.729, the Kaiser-Meyer-Olkin is 0.868, the Chi-Square in Bartlett's test is 15,606.788, and the  $P$  value is less than 0.001.

Definition of Analysis Indicators as follows:

Awareness rate (single question):

$$\frac{\text{number of participator who answer one of the core knowledge questions correctly}}{\text{total number of participators who attend the survey}} 100\%$$

The total awareness rate:

$$\frac{\text{total number of the core knowledge questions were answered correctly}}{\text{total number of participatosr who attend the survey} \times \text{total number of core knowledge question}} 100\%$$

Entire awareness rate:

$$\frac{\text{number of participators who answered all core knowledge questions correctly}}{\text{total number of participators who attend the survey}} 100\%$$

Behavioral Score Calculation: Yes (never): 2 points, Do not know (occasionally): 1 point, No (often): 0 point. By adding the scores of each question, calculate the behavior score.

## Quality Control

The questionnaire was revised after reviewing the opinions of the expert group. It has a complete health data management system for college and universities freshmen in Jiangsu Province, which can conduct online surveys. By uniform training, investigators have mastered the investigation requirements and methods, and are familiar with the investigation process. Professionals from health departments of universities and colleges served as quality controllers for this survey, accepted the questionnaires, reduced and eliminated invalid questionnaires (incomplete demographic data, and more than 4 missing items in the main list). Note: All questionnaires are filled out anonymously.

## Statistical Analysis

Use SPSS25.0 statistical software to analyze the data. Normal distribution measurement data is represented by mean  $\pm$  standard deviation ( $\bar{x} \pm s$ ); skew distribution measurement data is represented by the median (lower and upper quartile), which is P50 (P25, P75); counting data is expressed in percentage (%). The comparison between groups was performed by test, test standard=0.05,  $P < 0.05$  indicated the difference was statistically significant. Python 3.8.8 software was used to construct linear regression model, logistic regression model, decision tree model and random forest model, and adjust the parameters through grid searching method. SPSS Amos 25.0 establishes a structural equation model.

## Results

### Basic Information of the Participants

A total of 7254 questionnaires were collected. After eliminating 274 invalid questionnaires, there are 6980 valid questionnaires. The effective recovery rate was 96.22%. Among 6980 survey participants, 5130 (73.50%) were undergraduate University students, 1850 (26.50%) were college students, including 3375 (48.35%) male and 3605 (51.65%) female students; the average age of students is  $18.34 \pm 0.63$  years old, with a median and interquartile range of 18.00 (18.00, 19.00) years old; 3320 (47.56%) students were from the urban area of Jiangsu, and 3660 (52.44%) were from rural areas; 4202 of students (60.20%) are the only child in their family, 2778 (39.80%) are not (see [Table 1](#)).

### Awareness of Core Knowledge About Tuberculosis

The total awareness rate of tuberculosis prevention and treatment knowledge reached 89.02%; the total awareness rate was only 58.94%. The top three parts for the awareness rate in single question are: Seek medical condition (Q5), belong to major infectious diseases (Q1) and routes of transmission (Q2). The awareness rate of medical institutions (Q4) was the lowest, only 83.28%.

The awareness rate of 7 single questions among undergraduate freshmen is higher than college freshmen ( $P < 0.001$ ); the awareness rate of males in Q1, Q4, and Q6 is higher than female, and the awareness rate of females in Q5 and Q7 is higher than male ( $P < 0.05$ ). The awareness rates of Q1, Q3~Q5 and Q7 questions among students are from urban areas were higher than students who are from rural areas ( $P < 0.05$ ) (see [Table 2](#)).

### Factors Affecting Overall Awareness Rate of Core Knowledge About Tuberculosis

The overall awareness rate of 6980 freshmen was 58.94%. Based on general demographic information, general linear models, logistic regression models, decision tree models and random forest models can be constructed and applied to explore the factors that affect the overall awareness rate. According to the f1 score, the random forest model has the best screening results. The influence factors screened by random forest model are: type of institution, father's education degree, family monthly income, mother's education degree, gender and region; decision tree model: family monthly

**Table 1** Basic Situation of Participators

Basic Demographic Characteristics	Frequency	Constituent Ratio (%)
Type of institution		
University	5130	73.50
College	1850	26.50
Gender		
Male	3375	48.35
Female	3605	51.65
Age group		
Under 18 years old	4694	67.25
Above 18 years old	2286	32.75
Region		
Urban area	3320	47.56
Rural area	2316	33.18
Father's education level		
Primary school diploma or below	492	7.05
Junior school diploma	2530	36.25
High school diploma	1966	28.17
Bachelor's degree	1837	26.32
Master's degree or above	155	2.21
Mother's education level		
Primary school diploma or below	1000	14.33
Junior school diploma	2546	36.48
High school diploma	1932	27.68
Bachelor's degree	1424	20.40
Master's degree or above	78	1.11
Father's occupation		
Worker	2021	28.95
Farmer	299	4.28
Medical worker	124	1.78
Educational worker	328	4.70
Other scientific personnel	85	1.22
Business and service industries	1610	23.07
Unemployed	76	1.09
Others	2437	34.91
Mother's occupation		
Worker	1389	19.90
Farmer	407	5.83
Medical worker	228	3.27
Educational worker	461	6.60
Other scientific personnel	36	0.52
Business and service industries	1837	26.32
Unemployed	723	10.36
Others	1899	27.21
Family monthly income (RMB)		
≥1000	926	13.27
≥3000	1686	24.15
≥5000	1880	26.93
≥7000	1176	16.85
≥9000	1312	18.80
Only child or not		
Yes	4202	60.20
No	2778	39.80

(Continued)

**Table I** (Continued).

Basic Demographic Characteristics	Frequency	Constituent Ratio (%)
Living mode during high school period		
Live with father	196	2.81
Live with mother	799	11.45
Live with parents	3605	51.65
Live with grandparents	293	4.20
Live in dormitories	1940	27.79
Others	147	2.11

income, mother's occupation, father's occupation, mother's education degree and living mode during high school period; logistic regression model: type of institution, mother's education degree, age and mother's occupation; linear regression model: type of institution, father's education degree, gender and mother's occupation. Three models contain the type of institution, and it is the most important factor (see Figure 1 and Table 3).

## The Relationship Between Tuberculosis Prevention Knowledge, Attitudes and Behaviors

Selection of attitude and behavior questions among 6980 participants: 98.64% participants took positive attitudes or maintained positive behavior rates for Q8–14 were 64.70%, 96.62%, 97.89%, 97.87%, 98.05% and 98.37%. The Chi-square test was used for analyzing the positive rate of each question, and the result shows that the difference has statistical significance ( $\chi^2=10,307.88$ ,  $P<0.001$ ). After ranking the rates from small to large, the positive attitudes and behavior rates of Q13, Q14 and Q8 are higher, which all of them are more than 98%. Before establishing the structural equation model, according to exploratory analysis, the Cronbach's  $\alpha$  coefficients in each dimension of knowledge and attitude are all greater than 0.6. Because of KMO and Bartlett's sphericity test:  $P<0.001$ , this model can be able to construct.

By modeling and correcting according to MI, the evaluation index  $\chi^2=169.9$ ,  $\chi^2/df=5.5$ , GFI, AGFI and CFI are all greater than 0.90, RMSEA=0.03, AIC=217.9, BIC=382.3 shows that the constructed structural equation model is more excellent. The relationship between path analysis and measurement is shown in Figure 2. The path coefficient of knowledge and attitude is 0.29, the path coefficient of attitude and behavior is 0.64. Knowledge and behavior have indirect effects with a coefficient of 0.77. The detailed results are shown in Table 4.

## Discussion

Mycobacterium tuberculosis is highly infectious,<sup>12</sup> one case of open pulmonary tuberculosis can infect 10–20 Healthy people per year. Epidemics of tuberculosis on campus occur frequently.<sup>13</sup> Although the Chinese government has paid more attention to the prevention and control of TB among the student population,<sup>14</sup> there was still KAP gap on TB in this population. Therefore, it is necessary to understand the current status of knowledge, attitudes and practices about tuberculosis among freshmen from Jiangsu colleges and universities in time, adopts intervention in time to prevent tuberculosis occurs and spreads on campus in order to protect the lives of teachers and students, contribute to preventing the spread and outbreak of tuberculosis.<sup>10</sup>

The core knowledge of tuberculosis prevention and control among university and college freshmen in Jiangsu Province in 2020 is ranked from high to low: Seek Medical condition (Q5), belong to serious infectious disease (Q1), routes of transmission (Q2), can or cannot be cured (Q6), suspicious symptoms (Q3), relief policy (Q7), medical institution (Q4). Obviously, students do not pay enough attention to the certain exemption policy for tuberculosis patients, and they are not clear and definite about medical institutions. It requires further study to find out the reason is that students are not interested in such kind of knowledge, or school and family did not provide enough lecture about it. In general, due to the lack of understanding about national support and relief policies after getting tuberculosis, it may

**Table 2** Awareness of Core Knowledge About Tuberculosis

	Type of Institution				Gender				Region			
	Undergraduate n(%)	Collegen (%)	$\chi^2$ Value	P value	Male n(%)	Femalen (%)	$\chi^2$ Value	P value	Urban n(%)	Rural n(%)	$\chi^2$ Value	P value
Q1	4814 (93.84)	1612 (87.14)	84.15	<0.001	3141 (93.07)	3285 (91.12)	9.01	0.003	3089 (93.04)	3337 (91.18)	8.31	0.004
Q2	4760 (92.79)	1623 (87.73)	48.74	<0.001	3075 (91.11)	3308 (91.76)	0.94	0.332	3050 (91.87)	3333 (91.07)	1.43	0.232
Q3	4597 (89.61)	1500 (81.08)	92.05	<0.001	2970 (88.00)	3127 (86.74)	2.50	0.114	2943 (88.64)	3164 (86.17)	9.61	0.002
Q4	4411 (85.98)	1402 (75.78)	103.77	<0.001	2854 (84.56)	2959 (82.08)	7.72	0.005	2882 (86.81)	2931 (80.08)	56.61	<0.001
Q5	4993 (97.33)	1738 (93.95)	46.09	<0.001	3232 (95.76)	3499 (97.06)	8.52	0.004	3220 (96.99)	3511 (95.93)	5.68	0.017
Q6	4594 (89.55)	1547 (83.62)	46.87	<0.001	3017 (89.39)	3124 (86.66)	12.33	<0.001	2953 (88.95)	3188 (87.10)	5.59	0.018
Q7	4444 (86.63)	1460 (78.92)	64.61	<0.001	2850 (84.44)	3054 (84.72)	6.48	0.039	2838 (85.48)	3066 (83.77)	3.91	0.048

**Abbreviations:** Q1, Tuberculosis is an infectious disease that could seriously endanger human health?; Q2, Tuberculosis is mainly transmitted through droplets when patients cough, sneeze, or speak loudly?; Q3, Those who have a cough, cough up phlegm for more than two weeks, or have blood-stained sputum should be suspected of tuberculosis?; Q4, There are specialized institutions for Tuberculosis testing and treatment in cities and towns at or above the county level in China?; Q5, Tuberculosis patients should go to professional tuberculosis prevention and control institutions for testing, treatment and management?; Q6, As long as regular treatment is maintained, most tuberculosis cases can be cured?; Q7, Does our country provide free first-line anti-tuberculosis drugs and major tests for infectious tuberculosis patients?.

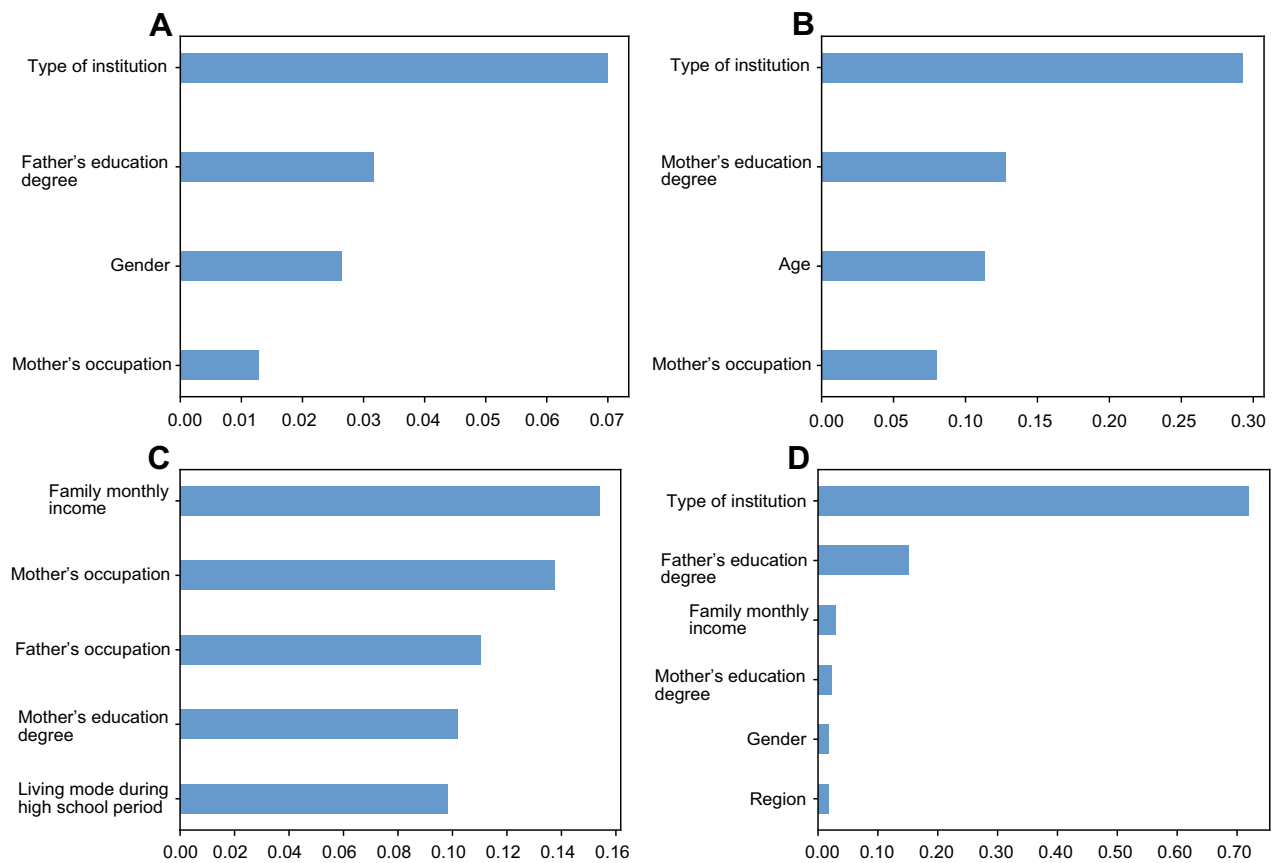

**Figure 1** Ranking of factors affecting overall awareness rate of core knowledge about TB in 4 models. (A) Linear regression model. (B) Logistic regression model. (C) Decision tree model. (D) Random forest model.

increase the pressure and confusion of students on examinations, diagnosis, treatment costs and medical institution choice, which against early-stage prevention, discovery, and treatment. The result is similar as an investigation in Beijing<sup>15</sup> and one study focused on Post-2000s generation.<sup>16</sup>

The total awareness rate of tuberculosis core knowledge was applied to evaluate the knowledge of tuberculosis prevention and control. The total awareness rate of freshmen was 89.02%, although this indicator reached the national target requirement (85%),<sup>17</sup> the result obtains in this study is similar to a study done in Malaysia.<sup>18</sup> Only using total awareness rate to evaluate students' awareness of tuberculosis has drawbacks because the total awareness rate will decrease with the increase of core knowledge questions. It needs to be evaluated combine with entire awareness rates, and that rate of all freshmen is only 58.94%. Song Luo and others<sup>19</sup> surveyed on students' awareness of four infectious diseases. Except for AIDS, the error rate of other diseases was high (including tuberculosis), which was consistent with the results of this survey. By analyzing many influence factors of awareness rate of all core knowledge, type of institution is one of the important factors that affect the awareness rate of all knowledge among freshmen. The overall

**Table 3** Evaluation of 4 Models

	f1-Score	RMSE	Absolute Error
Linear regression model	0.735	0.223	0.453
Logistic regression model	0.753	0.341	0.341
Decision tree model	0.771	0.390	0.390
Random forest model	0.774	0.368	0.368

**Abbreviation:** RMSE, root-mean-square error.

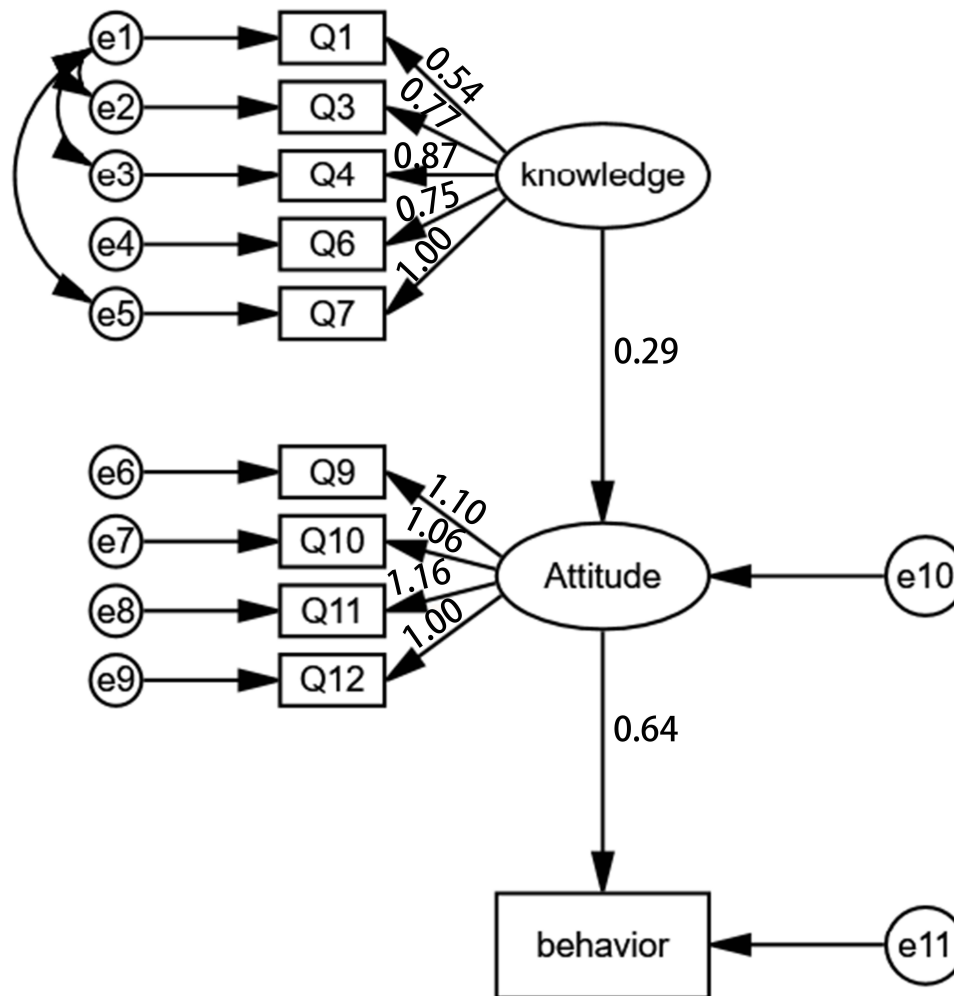

**Figure 2** Path analysis of structural equation model.

**Abbreviations:** Q1, Tuberculosis is an infectious disease that could seriously endanger human health?; Q3, Those who have a cough, cough up phlegm for more than two weeks or blood-stained sputum should be suspected of tuberculosis?; Q4, There are specialized institutions for Tuberculosis testing and treatment in cities and towns at or above the county level in China?; Q6, As long as regular treatment is maintained, most tuberculosis cases can be cured?; Q7, Does our country provide free first-line anti-tuberculosis drugs and major testings for infectious tuberculosis patients?; Q9, If someone around you gets tuberculosis, will you take the initiative to do Tuberculosis testing?; Q10, If you have a cough, cough up phlegm for more than two weeks, or blood-stained sputum, will you take the initiative to see doctor?; Q11, If you have tuberculosis, will you remind people around you to go to the hospital for tuberculosis-related testing?; Q12, If you have tuberculosis, would you choose to go to a professional tuberculosis prevention and control institution for treatment?.

awareness rate of tuberculosis among university students is higher than college students. Possible explanations for this finding include higher learning ability, higher health literacy, better access to health information and healthcare services of university freshmen. Based on the status of freshmen in colleges and universities, health education of tuberculosis knowledge should be strengthened among junior and senior high school students, and develop various forms of health education and promotion activities so that can increase the awareness rate of students. University and college administrators striving against TB should provide due attention to university and college settings and consider the development of student education programs to improve awareness and knowledge about TB.<sup>10</sup> The results also suggest that the awareness baseline levels of students in colleges and universities are different. It requires organizers to conduct health education suitably depending on their abilities and levels, increase the effort of health education about infectious diseases, and avoid uneven distribution of tuberculosis health education resources. Chinese families ubiquitously hold high hopes for their children, therefore, parents are obsessed with their children's improvement of academic performance and willing to take care of anything for their children. High school students rarely initiatively undertake affairs unrelated to studies due to the study pressure.<sup>20</sup> One study demonstrated that parents' knowledge of



**Table 4** Outcomes of Path Analysis

Path	Estimate	SE	CR	P
Knowledge→Attitude	0.29	0.01	20.71	<0.001
Attitude→Behavior	0.64	0.04	15.99	<0.001
Knowledge→Q7	1.00	–	–	–
Knowledge→Q6	0.75	0.03	23.60	<0.001
Knowledge→Q4	0.87	0.04	23.76	<0.001
Knowledge→Q3	0.77	0.03	23.14	<0.001
Knowledge→Q1	0.54	0.03	17.51	<0.001
Attitude→Q12	1.00	–	–	–
Attitude→Q11	1.16	0.03	41.64	<0.001
Attitude→Q10	1.06	0.03	37.90	<0.001
Attitude→Q9	1.10	0.03	32.46	<0.001

**Abbreviations:** SE, standard error; CR, critical ratios; Q1, Tuberculosis is an infectious disease that could seriously endanger human health?; Q3, Those who have a cough, cough up phlegm for more than two weeks or blood-stained sputum should be suspected of tuberculosis?; Q4, There are specialized institutions for Tuberculosis testing and treatment in cities and towns at or above the county level in China?; Q6, As long as regular treatment is maintained, most tuberculosis cases can be cured?; Q7, Does our country provide free first-line anti-tuberculosis drugs and major testings for infectious tuberculosis patients?; Q9, If someone around you gets tuberculosis, will you take the initiative to do Tuberculosis testing?; Q10, If you have a cough, cough up phlegm for more than two weeks, or blood-stained sputum, will you take the initiative to see a doctor?; Q11, If you have tuberculosis, will you remind people around you to go to the hospital for tuberculosis-related testing?; Q12, If you have tuberculosis, would you choose to go to a professional tuberculosis prevention and control institution for treatment?.

TB was the risk factor of TB in children.<sup>21</sup> So parents' education level affects students' awareness of tuberculosis, the parents with higher education may be further concerned about their childrens' health literacy. They have formed the habit of receiving health-related information since childhood, which affects the awareness rate. When the income per month increases in a family, the overall awareness rate increases as well. This may be related to a greater family income leads to more health-related expenditures and knowledge about tuberculosis,<sup>22</sup> which is consistent with the previous study.<sup>23</sup>

Most freshmen in both colleges and universities contain positive attitudes and behaviors of tuberculosis prevention and treatment. KAP improvement is still one of the most effective strategies for helping control and prevent TB. From the relationship between tuberculosis prevention knowledge, attitude and behavior, knowledge affect attitude, attitude affect behavior, and knowledge indirectly affects behavior through attitude, all three factors are inseparable. Once we achieve more comprehensive knowledge of tuberculosis more correct attitudes will be followed, the behaviors will develop positively, and vice versa. Therefore, to change behaviors, we must start through strengthen health education, improving negative attitudes towards tuberculosis, and guiding positive behaviors.<sup>24</sup> To improve students' knowledge of disease prevention and control via health education, to understand where they should be diagnosed and treated if they are sick, and what supporting policies are available to reduce their pressure. Adequate knowledge and positive attitudes about TB patients are expected to contribute to improved health care-seeking behavior,<sup>25</sup> and can reduce discrimination to a certain extent, and ultimately change behavior and reduce the spread of disease.

College and university students are at the peak of accepting knowledge with great pressure,<sup>26</sup> students gain more knowledge about TB disease after spending more time attending university or college.<sup>10</sup> Improving health education of the freshmen population, and popularizing the knowledge of tuberculosis prevention are the simplest and most feasible methods that schools can take to prevent the occurrence of tuberculosis. Knowing the exact cause of the disease is the baseline for having a positive attitude as well as for applying effective prevention methods.<sup>27</sup> At the same time, students can transmit knowledge to their families and friends.<sup>28</sup> It is necessary to understand the knowledge of tuberculosis prevention and control and health status of students in long term and obtain more reliable data support to provide the basis for prevention and treatment of tuberculosis in the future.

## Conclusion

The total awareness rate of core tuberculosis knowledge of Jiangsu college freshmen reaches the national requirements, but the overall awareness rate is low. It is necessary to strengthen the health education of tuberculosis for junior and high school students. Improving health education of freshmen population, and popularizing the knowledge of tuberculosis prevention are the simplest and most feasible methods that schools can take to prevent the occurrence of tuberculosis, especially for freshmen of colleges, in a low-income family, whose parents with less education and those with identified risk factors among this particular population.

## Limitations of the Study

There are several limitations to our study. Firstly, the information was collected using a self-administered questionnaire. Secondly, The honesty and the seriousness of the respondents to the questions are difficult to access and validate. Thirdly, we did not investigate the education level of students in high school, but we believe that the region of students can reflect the education level of their high school, the education level of high school in urban areas is higher than that in rural areas. Lastly, since this study was conducted in a higher educational institute, results cannot be generalized to the general population.

## Data Sharing Statement

The datasets analyzed in this study are available from the corresponding author Wei Li (weili126@126.com) after co-authors' approval of the request.

## Acknowledgments

We thank the freshmen who participated in this research.

## Funding

This work was supported by the Key Research Project of Jiangsu Province's "14th Five-Year Plan" Higher Education Scientific Research Plan (ZDDY12).

## Disclosure

The authors declare that they have no competing interests in this work.

## References

1. Allwood BW, Maasdorp E, Kim GJ, et al. Transition from restrictive to obstructive lung function impairment during treatment and follow-up of active tuberculosis. *Int J Chron Obstruct Pulmon Dis*. 2020;15:1039–1047. doi:10.2147/COPD.S219731
2. Jeremiah C, Mishal K, Francine N, et al. Global tuberculosis report 2020 - reflections on the global TB burden, treatment and prevention efforts. *Int J Infect Dis*. 2021;113:S7–S12.
3. Fei H, Yinyin X, Hui C, et al. The impact of the COVID-19 epidemic on tuberculosis control in China. *Lancet Reg Health West Pac*. 2020;3:100032. doi:10.1016/j.lanwpc.2020.100032
4. Huang L, Li XX, Abe EM, et al. Spatial-temporal analysis of pulmonary tuberculosis in the northeast of the Yunnan province, People's Republic of China. *Infect Dis Poverty*. 2017;6(1):53. doi:10.1186/s40249-017-0268-4
5. Jiang H, Zhang S, Ding Y, et al. Development and validation of college students' tuberculosis knowledge, attitudes and practices questionnaire (CS-TBKAPQ). *BMC Public Health*. 2017;17(1):949. doi:10.1186/s12889-017-4960-x
6. Yang Q, Tong Y, Yin X, et al. Delays in care seeking, diagnosis and treatment of patients with pulmonary tuberculosis in Hubei, China. *Int Health*. 2020;12(2):101–106. doi:10.1093/inthealth/ihz036
7. Zhang Y, Zhou L, Liu ZW, et al. Multidrug-resistant tuberculosis transmission among middle school students in Zhejiang Province, China. *Infect Dis Poverty*. 2020;9(1):57. doi:10.1186/s40249-020-00670-x
8. Getnet F, Demissie M, Assefa N, Mengistie B, Worku A. Delay in diagnosis of pulmonary tuberculosis in low-and middle-income settings: systematic review and meta-analysis. *BMC Pulm Med*. 2017;17(1):202. doi:10.1186/s12890-017-0551-y
9. Alema HB, Hailemariam SA, Misgina KH, et al. Health care seeking delay among pulmonary tuberculosis patients in North West zone of Tigray region, North Ethiopia. *BMC Infect Dis*. 2019;19(1):309. doi:10.1186/s12879-019-3893-7
10. Mekonnen A, Collins JM, Klinkenberg E, et al. Tuberculosis knowledge and attitude among non-health science university students needs attention: a cross-sectional study in three Ethiopian universities. *BMC Public Health*. 2020;20(1):631. doi:10.1186/s12889-020-08788-1
11. Cao D, Zhang Z, Yang Z, et al. The association between tuberculin skin test result and active tuberculosis risk of college students in Beijing, China: a retrospective cohort study. *BMC Infect Dis*. 2019;19(1):619. doi:10.1186/s12879-019-4238-2

12. Pai M, Behr MA, Dowdy D, et al. Tuberculosis. *Nat Rev Dis Primers*. 2016;2(1):16076. doi:10.1038/nrdp.2016.76
13. Bao H, Liu K, Wu Z, et al. Tuberculosis outbreaks among students in mainland China: a systematic review and meta-analysis. *BMC Infect Dis*. 2019;19(1):972. doi:10.1186/s12879-019-4573-3
14. Wang X, Jiang H, Wang X, Liu H, Zhou L, Lu X. ESMPE: a combined strategy for school tuberculosis prevention and control proposed by Dalian, China. *PLoS One*. 2017;12(10):e0185646. doi:10.1371/journal.pone.0185646
15. Gao Z, Li Y, Xu Y, He X. A comparative analysis of the survey on awareness rate of tuberculosis key messages among the public in Beijing in 2006 and 2015. *Health Med Res Pract*. 2020;17(06):5–11+26.
16. Wu T, Chen L, Pan J, et al. Investigation on cognition, attitude and health education demand of tuberculosis among freshmen born after 2000. *J Guangxi Med Univ*. 2020;37(10):1891–1895.
17. Chen X, Wang W, Wang X, et al. Public awareness of tuberculosis in Southeast China: a population-based study. *Int J Environ Res Public Health*. 2019;16:21. doi:10.3390/ijerph16214290
18. Jamaludin TSS, Ismail N, Saidi S. Knowledge, awareness, and perception towards tuberculosis disease among International Islamic University Malaysia Kuantan students. *Enferm Clin*. 2019;29:771–775. doi:10.1016/j.enfcli.2019.04.116
19. Luo S, Li S. Investigation and analysis of 2746 high school students' cognition of four common infectious diseases. *Chin Youjiang Med J*. 2020;48(10):769–774.
20. Zhang S, Li X, Zhang T, Fan Y, Li Y. The experiences of high school students with pulmonary tuberculosis in China: a qualitative study. *BMC Infect Dis*. 2016;16(1):758. doi:10.1186/s12879-016-2077-y
21. Putra GS, Dewi RRR, Hapsari DI, Hariana E, Leksono AAD. Parents' knowledge as a risk factor of tuberculosis in children. Paper presented at: 5th Universitas Ahmad Dahlan Public Health Conference (UPHEC 2019); 2020.
22. Li X, Huang M, Xu W, Zhang Y, Wu W, Shen X. Knowledge, attitude, practice of pulmonary tuberculosis prevention and treatments and relevant influence factors. *Chin J Health Educ*. 2008;2008(02):89–91+98.
23. Cheng J, Sun YN, Zhang CY, et al. Incidence and risk factors of tuberculosis among the elderly population in China: a prospective cohort study. *Infect Dis Poverty*. 2020;9(1):13. doi:10.1186/s40249-019-0614-9
24. Idris NA, Zakaria R, Muhamad R, Nik Husain NR, Ishak A, Wan Mohammad WMZ. The effectiveness of tuberculosis education programme in Kelantan, Malaysia on knowledge, attitude, practice and stigma towards tuberculosis among adolescents. *Malays J Med Sci*. 2020;27(6):102–114. doi:10.21315/mjms2020.27.6.10
25. Datiko DG, Habte D, Jerene D, Suarez P. Knowledge, attitudes, and practices related to TB among the general population of Ethiopia: findings from a national cross-sectional survey. *PLoS One*. 2019;14(10):e0224196. doi:10.1371/journal.pone.0224196
26. Zhou H. Epidemiological investigation of pulmonary tuberculosis patients of different age groups in Pingshan District, Shenzhen. *J Math Med*. 2021;34(02):231–233.
27. Angelo AT, Geltore TE, Asega T. Knowledge, attitude, and practices towards tuberculosis among clients visiting tepi general hospital outpatient departments, 2019. *Infect Drug Resist*. 2020;13:4559–4568. doi:10.2147/IDR.S287288
28. Tian H, Wang D. Effects of the health education of tuberculosis prevention and control among college students based on Wechat group. *Chin J Sch Health*. 2017;38(05):680–682.

## Infection and Drug Resistance

Dovepress

### Publish your work in this journal

Infection and Drug Resistance is an international, peer-reviewed open-access journal that focuses on the optimal treatment of infection (bacterial, fungal and viral) and the development and institution of preventive strategies to minimize the development and spread of resistance. The journal is specifically concerned with the epidemiology of antibiotic resistance and the mechanisms of resistance development and diffusion in both hospitals and the community. The manuscript management system is completely online and includes a very quick and fair peer-review system, which is all easy to use. Visit <http://www.dovepress.com/testimonials.php> to read real quotes from published authors.

Submit your manuscript here: <https://www.dovepress.com/infection-and-drug-resistance-journal>