

The Influence of Personal Motivation and Innovative Climate on Innovative Behavior: Evidence from University Students in China

Qiwen Dai¹, Yanhong Dai¹, Chunyu Zhang¹ , Zhiming Meng², Zeyu Chen¹, Senlin Hu³

¹School of Economics and Management, Guangxi Normal University, Guilin, People's Republic of China; ²School of Innovation and Entrepreneurship, Guangxi Normal University, Guilin, People's Republic of China; ³School of Urban Development Research, East China Normal University, Shanghai, People's Republic of China

Correspondence: Chunyu Zhang, School of Economics and Management, Guangxi Normal University, Guilin, Guangxi, 541004, People's Republic of China, Email 468160345@qq.com

Purpose: Drawing on the motivation theory, this study investigated the effect and consequences of personal motivation and innovative climate on innovative behavior among university students in mainland China. The study also examined whether the effect of personal motivation and innovative climate on Chinese university students' innovative behavior is heterogeneous between disciplines and place of residence.

Methods: A quantitative study was conducted to test the hypotheses. Data were collected from 245 undergraduate students at Chinese universities with paper-based questionnaires. Self-report scales were used to measure levels of personal motivation, innovative climate, and innovative behaviors. A confirmatory factor analysis was used to test the scale and questionnaire's reliability and validity. The logistic model was applied to analyze the data and test the hypotheses.

Results: Personal motivation and innovative climate have significant effects on Chinese university students' innovative behavior. The effect of personal motivation and innovative climate on students' innovative behavior is heterogeneous between disciplines and place of residence. Further, extrinsic motivation serves as a positive incentive. Mentor support, good academic climate, and knowledge sharing affect students' innovative behavior positively. However, insufficient guaranteed resources has a significant negative influence. The data demonstrated no statistically significant difference between intrinsic motivation and students' innovative behavior.

Conclusion: This study contributes to the empirical literature on mechanisms that influence innovative behavior by testing the relation between personal motivation, innovative climate, and innovative behavior on the part of Chinese university students. In addition, these findings also provide evidence for ways to improve university students' innovative consciousness and innovative ability, as well as universities' management practice of innovative education.

Keywords: innovative behavior, personal motivation, innovative climate, university students

Introduction

Individuals' innovative behavior is a source of power to achieve their own sustainable development,¹ and university students (hereinafter, students), as a new force, play an important role in promoting the innovative development of society.² The government, enterprises, scientific research institutes, universities, and other groups in various fields are committed to promoting innovation and have achieved remarkable results.³ However, research on students' innovative behavior is still in the exploratory stage. Previous research on innovative behavior has focused on the individual and organizational levels. The individual level includes such abilities as creative self-efficacy,⁴ intrinsic motivation,⁵ knowledge sharing, innovative passion, and absorptive capacity,⁶ while the organizational level comprises such factors as creative leadership and innovative climate.⁷ The influence of personal motivation and innovative climate on innovative behavior has received more attention recently. Intrinsic motivation is considered to be the most dominant motivation in innovative behavior in acquiring knowledge.⁸ However, under certain conditions, extrinsic incentives undermine intrinsic

motivation.⁹ An innovative climate has a significant role in promoting individual innovative behavior.⁷ However, it includes several dimensions, such as resource support, knowledge sharing, and academic climate, that have significantly different effects on innovative behavior.

With respect to research subjects, those who engage in innovative behavior include enterprise employees,² scientific researchers,¹⁰ entrepreneurs,¹¹ teachers,¹² and students.¹³ The key to innovation in colleges and universities depends upon students, and their innovative behavior determines the competitiveness of colleges and universities and even the country to a certain extent.¹³ The research question is what kind of innovative behavior do students exhibit since the Ministry of Education of China implemented a training program for students' innovation and entrepreneurship? In management practice, how does one stimulate students' innovative behavior by improving personal motivation and the innovative climate?

This study defines students' innovative behavior, the main dimensions of personal motivation, and innovative climate. The relation between personal motivation, including intrinsic and extrinsic motivation, and innovative climate, including mentor support, guaranteed resources, academic climate, knowledge sharing, and students' innovative behaviors, was investigated to explore the influence of innovative climate and personal motivation on students' innovative behavior, as well as to provide a theoretical basis to suggest ways to improve their innovative consciousness and innovative ability, universities' innovation and entrepreneurship, education reform, and the high-quality development of innovation and entrepreneurship.

Theoretical Background and Hypotheses

Personal Motivation and Individual Innovative Behavior

Innovative behavior at the individual level has long been a concern.^{5,6} Innovative behavior is defined as the process of asking questions and conceiving solutions, seeking support for one's ideas, and realizing one's innovative ideas.¹⁴ In view of the above, students' innovative behavior is defined as a series of changes in which they generate innovative ideas and try to put them into practice in the process of learning and participating in scientific and technological activities.

Personal innovative motivation, which includes primarily intrinsic and extrinsic motivation, is the internal psychological process that generates and sustains a person's innovative activity¹⁵ and is a prerequisite in eliciting innovative behavior. Intrinsic motivation refers to an individual's interest or willingness to face challenges, while extrinsic motivation depends upon external incentives, such as rewards and encouragement.¹⁶ This study draws on Self-Determination Theory (SDT), a leading theory in which intrinsic motivation is seen as a powerful motivation that leads to several positive outcomes. When a person is motivated intrinsically, they engage in an activity for its inherent satisfaction.¹⁷ The extent to which the surrounding environment supports people's basic psychological needs is central to eliciting intrinsic motivation.¹⁸ SDT posits that individuals have three innate psychological needs—competence, autonomy, and relatedness. Environments in which these basic needs are not fulfilled sufficiently may inhibit intrinsic motivation.¹⁹ Therefore, we argue that students' innovative motivation is the determining force of their innovative ability, which depends upon both intrinsic and extrinsic motivation.¹⁶ Individuals' willingness to engage in innovative behavior increases when it is challenging or entertaining. Intrinsic incentives, such as the sense of pleasure and accomplishment that students reap through innovative behaviors generate intrinsic motivation.²⁰ When intrinsic motivation is high, they take the initiative to think of ideas that are more conducive to innovative behaviors.²¹

Extrinsic incentives, such as others' recognition of, or reward for, innovative behavior, generate extrinsic motivation. Previous research has shown that intrinsic motivation has a direct and significant effect on individual innovative behavior,⁵ while extrinsic motivation, which originates from the external environment and is attributable to recognition, can also promote innovative behavior.²² Consequently, based upon the findings in the literature, the following hypotheses are proposed:

H1: Personal motivation has a significant positive effect on students' innovative behavior.

H1a: Intrinsic motivation has a significant positive effect on students' innovative behavior.

H1b: Extrinsic motivation has a significant positive effect on students' innovative behavior.

Innovative Climate and Individual Innovative Behavior

The situational strength theory (SST) states that the situational strength of an individual's organization (such as a leader's behavioral style and organizational climate) can provide important external conditions that affect an individual's behavioral performance and intention.²³ Psychological factors, such as individual traits, interests, values, cognition, and emotions, have an important effect on transforming behavioral performance and intentions. Further, situational strength affects behavior/intentions through individual psychological factors. An innovative organizational climate is a perceptual description of an environment in which employees work²⁴ that includes challenge, freedom, trust, time to develop ideas, playfulness, idea support, debate, and risk taking.²⁵ In view of this, in this study, climate is defined as one that includes four characteristics that influence students' innovative behavior: mentor support; guaranteed resources; academic climate, and knowledge sharing.

Many studies have found that an innovative climate has a significant effect on innovative behavior.^{25–29} For example, leader-member exchange has been found to affect employees' innovative behavior in the Korean government sector.²⁶ Therefore, this study posits that the communication between teachers and students will promote students' innovative behavior. Yesil and Dogan found that social capital was related positively to innovative capability, and had a direct effect on innovation.³⁰ Further, social capital was correlated positively with knowledge sharing behavior.³¹ Accordingly, it is proposed that:

H2: An innovative climate has a significant positive effect on students' innovative behavior.

H2a: Mentor support has a significant positive effect on students' innovative behavior.

H2b: Guaranteed resources has a significant positive effect on students' innovative behavior.

H2c: Academic climate has a significant positive effect on students' innovative behavior.

H2d: Knowledge sharing has a significant positive effect on students' innovative behavior.

In general, from the perspective of SDT and SST, this study analyzes the psychological mechanism of the influence of personal motivation and innovative climate on innovative behavior. The conceptual framework of this study is shown in Figure 1.

Research Methodology

Participants and Procedures

The participants were undergraduates from universities in China. 1014 questionnaires were distributed and 1000 were returned. 814 valid questionnaires were obtained after those with missing information were excluded, for a valid response rate of 80.3%. A total of 245 samples with innovative behaviors was selected from the 814 questionnaires.

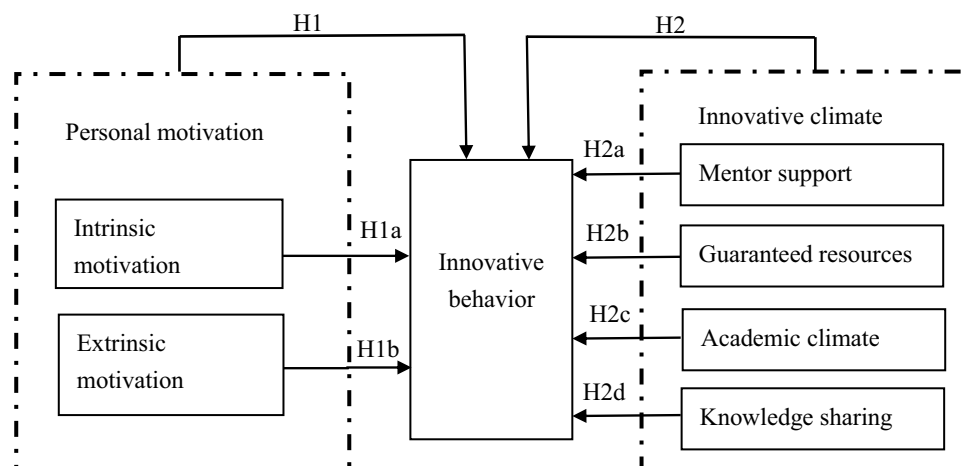

Figure 1 Conceptual Framework.

The demographics of the population surveyed is as follows. The participants included 88 (35.92%) men and 157 (64.08%) women. With respect to their place of residence, 61.22% of the respondents live in urban areas and 38.78% in rural areas. 75.10% of the respondents live in the Western region and 24.90% live in the Central and Eastern regions. With respect to the respondents' nationality, the Han people and Zhuang people accounted for 76.33% and 18.37%, respectively, while others accounted for 5.31%. With respect to family structure, 33.47% came from one-child families, while 66.53% came from multi-child families. With respect to grade distribution, 0.82% were freshmen, 27.76% sophomores, 41.63% juniors, and 29.80% seniors. With respect to the disciplines, 62.45% of the students majored in liberal arts and 37.55% majored in sciences. With respect to experience, 86.53% of the respondents had served as student cadre and 7.76% had served in the university association for science and technology.

Study Measures

We employed a logistic model to investigate the effect of personal motivation and innovative climate on students' innovative behavior and the heterogeneity effect of disciplines and place of residence. The model's general form is as follows.

$$PO_i = \alpha + \beta_1 IA_i + \beta_2 IM_i + \beta X_i + \varepsilon_i$$

in which i represents undergraduate, the dependent variable, PO_i , reflects innovative behavior, and the independent variables, IA_i and IM_i , reflect innovative climate and personal innovative motivation, respectively; X_i are control variables, α is a constant term, β , β_1 and β_2 are regression coefficients, and ε_i is the error term.

Dependent Variable

Consistent with previous authors' approach,^{32,33} innovative behavior was measured in three dimensions: creative performance; innovative activities, and innovative results. Given that innovative results reflect students' innovative behavior best,³⁴ the project outcomes achieved by those who participate in scientific and technological innovative activities were selected as the dependent variable to measure innovative behavior.

Independent Variables

Based upon previous studies, such as that by Richardson and Mishra,³⁵ mentor support, guaranteed resources, academic climate, and knowledge sharing are chosen as the indicators to measure the innovative climate. "Mentor guidance" and "mentor's role" were selected as the variables to measure mentor support; "insufficient funding", "poor laboratory conditions", "methodological and technological barriers", "weak team members", and "insufficient time" were selected as the variables to measure the absence of guaranteed resources; "knowledge of innovative activities", "literature review", "participation in academic reports" and "knowledge of academic articles" were selected as the variables to measure academic climate, and "participation in trainings" and "classmates' participation" were selected as the variables to measure knowledge sharing. Following Amabile et al³⁶ we measured personal motivation in two dimensions, intrinsic and extrinsic motivation. "Interest in scientific activity" was used to measure intrinsic motivation, while "participation in mentor's projects", "planning to attend graduate school", "experience of research or experiments", "time spent in innovative activities" and "self-designed project" were selected as the variables to measure extrinsic motivation.

Control Variables

Following Ramsey et al.³⁷ Tu et al³⁸ and Shen et al³⁹ we incorporate the following control variables into the models. Gender, nationality, and grade reflect and control for a student's individual characteristics and differences; served as student cadre and in the university association for science and technology reflect and control for a student's individual experience; one-child families reflect and control for a student's family structure, and location of student's residence reflects and controls for urban-rural differences and regional effects. Each variable's definition and measurement is shown in Table 1.

The questionnaire sees the [Appendix 1](#).

Table 1 Variable Measurements

Variable Type	Variable Name	Variable Symbol	Description
Dependent variable	Project outcomes	<i>PO</i>	Publish articles/apply for patents/ technology transfer=1, otherwise=0
Independent variable	Mentor guidance	<i>MG</i>	Do nothing =0, otherwise =1
	Mentor's role	<i>MR</i>	Facilitator =0, leader=1
	Insufficient funding	<i>IF</i>	Yes=1, no=0
	Poor laboratory conditions	<i>PLC</i>	Yes=1, no=0
	Methodological and technological barriers	<i>MTB</i>	Yes=1, no=0
	Weak team members	<i>WTM</i>	Yes=1, no=0
	Insufficient time	<i>IT</i>	Yes=1, no=0
	Knowledge of innovative activities	<i>KIA</i>	Do not know—know well 0–4
	Literature review	<i>LR</i>	Yes=1, no=0
	Participation in academic reports	<i>PAR</i>	Continuous variable
	Knowledge of academic articles	<i>KAA</i>	Do not know—know well 0–4
	Participation in trainings	<i>PT</i>	Yes=1, no=0
	Participation of classmates	<i>PC</i>	Yes=1, no=0
	Interest in scientific activity	<i>ISA</i>	Yes=1, no=0
	Participation in mentor's project	<i>PMP</i>	Yes =1, otherwise=0
	Plan to attend graduate school	<i>PAGS</i>	Yes=1, no=0
	Experience of research or experiments	<i>ERE</i>	No=0, otherwise =1
	Time to attend innovative activities	<i>TIME</i>	No participation=0, Freshman=4, sophomore=3, junior=2, senior =1
Self-designed project	<i>SD</i>	Yes =1, otherwise=0	
Control variable	Gender	<i>GENDER</i>	Male=1, female=0
	Nationality	<i>NATION</i>	Han nationality=1, minority=0
	Grade	<i>GRADE</i>	Freshman=1, sophomore=2, junior=3, senior=4
	Served as student cadre	<i>SC</i>	Yes=1, no=0
	Served in university association for science and technology	<i>UAST</i>	Yes=1, no=0
	One-child families	<i>OCF</i>	Yes=1, no=0
	Location of student's home	<i>LSH</i>	Set up dummy variables with reference to East Urban=1, rural=0

Reliability and Validity Tests

The reliability of the questionnaire was acceptable for the students' total innovative behavior (Cronbach's $\alpha = 0.76$) and for the subscales as well, with Cronbach's α greater than 0.60. Cronbach's α values for personal motivation (0.61) and

creative climate (0.74) were both acceptable. The validity of the questionnaire's original version was acceptable for the students' total innovative behavior (KMO = 0.69) and for the subscales, with KMO greater than 0.60. Further, KMO values for personal motivation (0.64) and creative climate (0.71) were both acceptable.

The values of Bartlett's Test of Sphericity were all significant at the 1% statistical level, and the cumulative contribution rates of the factors extracted were all greater than 50%, indicating that there is a good correlation between the variables selected, which is suitable for exploratory factor analysis. Using the maximum variance method to maximize the orthogonal rotation, the rotated factor loading matrix is obtained and the common factor is extracted. The variables' factor loadings were all greater than 0.5, indicating that the questionnaire and scales' structural validity is acceptable.

Results

Based upon the estimation of the benchmark regression model, a further heterogeneity analysis was performed. According to the discipline categories and students' places of residence, the heterogeneity effects of liberal arts and science students, and students from the Western, and Central and Eastern regions are analyzed. A total of five models was developed: M1 for the full sample of all students; M2 for the science students group; M3 for the liberal arts students group; M4 for students from the Western region, and M5 for the students from the Central and Eastern regions.

Regression Analysis

The results of the M1 model in Table 2 show that guaranteed resources and knowledge sharing have a significant negative effect on students' innovative behavior, while insufficient resources have a significant negative effect on their innovative behavior, such as methodological and technological barriers that constrain the production of innovative results ($\beta = -0.57, p < 0.1$). Knowledge sharing also has a significant effect on the students' innovative behavior. For example, participating in trainings has a negative effect on the output of innovative achievements ($\beta = -0.23, p < 0.10$). Some students may choose to give up after they understand scientific and technological innovative activities further through communication and sharing, which thus inhibits innovative behavior. However, the participation of classmates whom they know promotes their innovative achievement ($\beta = 1.06, p < 0.01$). Familiar students' participation in demonstrating innovative activities has an encouraging effect, and students' communication, exchange, and cooperation are more likely to lead to good project results. However, mentor support and academic climate had no significant effects on students' innovative behavior.

Intrinsic motivation did not play a role, while extrinsic motivation played a positive role to a certain extent. Participation in mentor's research projects had a significant effect on the achievement of innovative results ($\beta = 1.71, p < 0.01$). Compared with students who had not participated in their tutor's scientific research projects, those who had are more likely to have more scientific research opportunities and gain more research training, both of which are conducive to achieving positive project results. In contrast, self-designed projects were not conducive to achieving innovative results ($\beta = -0.57, p < 0.1$). Compared with a proposal the supervisor prepared, students with self-designed projects are more motivated, but their lack of academic understanding did not help advance the project and acquisition of results.

The control variables also had a significant effect on innovative behavior. One-child families were more likely to achieve innovative results than multi-child families ($\beta = 0.80, p < 0.05$). Families with one child invest more in education, and their children have more opportunities to engage in scientific and technologically innovative activities, and are more likely to engage in innovative behaviors. Students with student cadre experience tended to be less likely to achieve innovative results ($\beta = -0.84, p < 0.05$). Serving as a student cadre takes up much time, and results in insufficient ability to concentrate on university work, and therefore, makes it difficult to achieve innovative results.

Disciplinary Heterogeneity Analysis

To investigate in depth whether there are differences in the factors that influence the innovative behavior of students from different disciplines, the sample was divided into two groups: science students and liberal arts students. The results of a regression analysis of models M2 and M3 showed that innovative climate and personal motivation's effects on the innovative behavior of students from different disciplines had quite significant differences.

Table 2 Results of Stratified Regression Analysis

Independent variable	M1	M2	M3	M4	M5
MG	1.08 (1.04)		0.96 (0.71)	1.72 (1.23)	6.16* (1.83)
MR	0.09 (0.27)	0.76 (0.91)	-0.49 (-1.00)	0.50 (1.20)	-2.83* (-1.82)
IF	0.04 (0.11)	1.59* (1.70)	-0.31 (-0.61)	-0.04 (-0.09)	1.50 (1.23)
PLC	-0.31 (-0.90)	-1.58** (-2.08)	0.09 (0.16)	-0.28 (-0.64)	-0.60 (-0.52)
MTB	-0.57* (-1.63)	-0.30 (-0.33)	-1.27** (-2.41)	-0.53 (-1.20)	-0.52 (-0.53)
WTM	-0.08 (-0.25)	-0.34 (-0.37)	-0.69 (-1.36)	-0.38 (-0.90)	1.61 (1.12)
IT	-0.25 (-0.74)	-0.83 (-0.89)	0.15 (0.30)	-0.13 (-0.33)	-0.57 (-0.46)
KIA	-0.06 (-0.33)	0.11 (0.23)	-0.25 (-1.00)	-0.04 (-0.20)	0.45 (0.81)
LR	-0.23 (-0.35)		-0.60 (-0.69)	0.74 (0.88)	-2.02 (-1.00)
PAR	0.16 (1.46)	0.02 (0.07)	0.28* (1.69)	0.06 (0.45)	0.38 (1.00)
KAA	0.06 (0.26)	0.99** (1.93)	-0.05 (-0.17)	-0.09 (-0.29)	-0.50 (-0.95)
PT	-0.23* (-0.65)	-0.54 (-0.64)	-0.41 (-0.73)	0.28 (0.62)	-2.23* (-1.88)
PC	1.06*** (3.26)	0.79 (0.88)	1.70*** (3.23)	0.78** (1.94)	4.21*** (2.77)
ISA	-0.38 (-0.87)	-2.25* (-1.72)	-0.11 (-0.18)	-0.96* (-1.78)	-0.04 (-0.03)
PMP	1.71*** (3.12)	1.00 (0.84)	2.00*** (2.49)	1.75*** (2.63)	4.86*** (2.65)
PAGS	0.32 (0.89)	0.57 (0.53)	0.39 (0.77)	-0.07 (-0.16)	2.92** (2.01)
ERE	1.02 (1.41)	2.00* (1.45)	1.58 (1.22)	1.10 (1.39)	1.26* (1.66)
TIME	-0.16 (-0.61)	-1.16* (-1.54)	0.17 (0.44)	-0.37 (-1.14)	0.78 (0.76)
SD	-0.57* (-1.77)	-0.05 (-0.05)	-0.70* (-1.51)	-1.20*** (-2.84)	3.33** (2.03)
Control variable	YES	YES	YES	YES	YES
_cons	-3.15* (-1.63)	-2.72 (-0.72)	-3.73 (-1.37)	-2.57 (-1.12)	-16.09** (-2.15)
LRchi2	47.02	28.46	44.89	44.88	36.17
Prob>chi2	0.01	0.29	0.02	0.01	0.07
PseudoR2	0.15	0.30	0.24	0.19	0.43

Note: z-scores in parentheses, * $p < 0.10$, ** $p < 0.05$, *** $p < 0.01$.

Insufficient funding and poor laboratory conditions have significant effects on science students' innovative behavior, but the effect's direction differs. Poor laboratory conditions obviously restrict science students' innovative achievements ($\beta = -1.58$, $p < 0.05$), as it is difficult for them to complete projects without the support of a laboratory. However, the lack of guaranteed funding plays a certain role in promoting their achievement of project results ($\beta = 1.59$, $p < 0.10$). This may be attributable to the lack of funding, as students' research projects are funded largely with project funds or special funds their instructors provide. However, lack of a laboratory and guaranteed funding had no significant effect on liberal arts students. Projects' methodological and technical difficulty had a significant negative effect on liberal arts students' project achievements ($\beta = -1.27$, $p < 0.05$), but had no significant effect on science students' innovative achievements. Science students generally have a better foundation in mathematics and better mastery of technical methods, while liberal arts students tend to have weaker mathematical skills and lack methodological and technical mastery. Therefore,

technical methods constrain their innovative achievements to a greater degree. The difference in the need for guaranteed resources between liberal arts students and science students who participate in innovative science and technology activities led the innovative climate to have different effects on the students' innovative behavior. Participation in academic reports has a significant positive correlation with liberal arts students' innovative achievements ($\beta=0.28$, $p<0.10$), but has no significant relation with science students' achievements. Because liberal arts students' innovative achievements require more knowledge exchange and accumulation, they can acquire more academic knowledge, methods, and skills by participating in academic reports, which promotes project outputs. Knowledge of academic articles has a significant effect on science students' innovative achievements ($\beta=0.99$, $p<0.05$). To a certain extent, writing academic papers is more normative, so the more knowledge they have about writing academic papers, the more it helps science students achieve innovative results. Further, their classmates' participation plays a significant role in promoting liberal arts students' innovative achievements ($\beta=1.70$, $p<0.01$).

There are also clear disciplinary differences in intrinsic and extrinsic motivation's influence on students' innovative achievements. Counterintuitively, interest in scientific activity is not conducive to science students' innovative achievements ($\beta=-2.25$, $p<0.10$). Most students' interest in scientific research activities is in the perceptual stage. They may choose to retreat or treat them negatively as their understanding deepens. This also reflects that the transformation of motivation into results requires certain conditions. Intrinsic motivation is a necessary, but not sufficient, condition for innovative achievements, and it also requires students' efforts and implementation. Experience with research or experiments helps science students achieve innovative results ($\beta=1.00$, $p<0.10$), but the time necessary to spend on innovative activities was correlated significantly and negatively with science students' innovative behavior ($\beta=-1.16$, $p<0.10$). This indicates that it is not easy for students in lower grades to obtain project results. Participating in their mentor's project can help liberal arts students achieve innovative results ($\beta=-2.00$, $p<0.01$), while self-designed projects have a significant negative effect on their innovative achievements ($\beta=-0.70$, $p<0.01$).

The influence of the students' basic characteristics on their innovative behavior also shows clear disciplinary and regional heterogeneity. Liberal arts students from one-child families are more likely to achieve innovative results than those from multi-child families ($\beta=1.03$, $p<0.10$), and the experience as a student cadre has a negative effect on liberal arts students' innovative behavior ($\beta=-1.02$, $p<0.10$). Compared with science students from the Eastern region, those from the Central and Western regions are more likely to make innovative achievements ($\beta=3.23$, $p<0.10$; $\beta=3.41$, $p<0.10$). As most of the universities surveyed are located in the West, the majority of the students come from the Western and Central regions, which offers no clear advantage, while the quality of the Eastern students is generally not high. Thus, only greater diligence and hard work are conducive to achieving innovative results.

Analysis of Heterogeneity in Place of Residence

To investigate in depth whether there are differences in the factors that influence the innovative behavior of students from different locations, the sample was divided into two groups: Western, and Central and Eastern students. The results of a regression analysis of models M4 and M5 showed that innovative climate and personal motivation's influence on the innovative behavior of students from different locations differed quite significantly.

Mentor guidance can promote the innovative achievements of students from the Central and Eastern regions significantly ($\beta=6.156$, $p<0.10$), but when the mentor is the leader, s/he performs most of the project work, which has a significant negative effect on the innovative achievements of students in the Central and Eastern regions ($\beta=-2.83$, $p<0.10$). This indicates that mentor support is conducive to the generation of innovative behaviors, but the instructor should play the role of facilitator rather than leader. The mentor's dominance may limit students' innovative thinking to a certain extent, make them dependent, and thus, be detrimental to achieving innovative results. Participation in trainings does not help students in the Central and Eastern regions achieve innovative outcomes ($\beta=-2.23$, $p<0.10$), while their classmates' participation has a positive effect on students in all regions ($\beta=0.78$, $p<0.05$; $\beta=4.21$, $p<0.01$).

Interest in scientific activity is not conducive to students' innovative output in the Western region ($\beta=-0.96$, $p<0.10$), while participating in their mentor's project promotes the innovative behavior of students in all regions ($\beta=1.75$, $p<0.01$; $\beta=4.86$, $p<0.01$). Planning to attend graduate school and experience with research or experiments promotes students'

innovative behavior ($\beta=2.92$, $p<0.05$; $\beta=1.26$, $p<0.10$) in the Central and Eastern regions. In addition, self-designed projects have significant regional heterogeneity, and have a negative effect on the innovative achievements of students in the Western region ($\beta=-1.20$, $p<0.01$), while they have a significant positive effect on students in the East ($\beta=3.33$, $p<0.05$). Perhaps because students in the Eastern region are better educated and engage in innovative thinking actively, self-learning is more likely to produce innovative results.

The basic attributes of the sample, such as gender, one-child families, and experience serving as a student cadre, have a significant effect on the innovative behavior of students in the Western region. Male students and students from one-child families are more likely to have innovative achievements ($\beta=0.71$, $p<0.05$; $\beta=0.95$, $p<0.10$), and having student cadre experience weakens students' innovative achievements in the Western region.

Conclusions and Recommendations

Theoretical Significance

Our study findings have theoretical implications for the literature on innovative behavior. Previous research has focused on employees,⁶ and there are few specific studies from the perspective of students. Further, personal motivation and innovative climate's effects on innovative behavior have been studied insufficiently. Students' innovative behavior is still a new research topic, and there is no consensus in the academic community on its structural nature or theoretical basis. Our study is one of the few to investigate personal motivation and innovative climate's effects on students' innovative behavior.

First, based upon the SDT and SST, this paper reveals the relation between personal motivation, innovative climate, and innovative behavior. An innovative climate is an important factor that influences students' innovative behavior positively. In showing that an innovative climate stimulates students' innovative behavior, our empirical results are consistent with and enrich Liu et al and Deng et al's findings.^{29,40} Our findings showed that mentor support has a significant effect on the innovative behavior of students only in the Central and Eastern regions, and an insufficient guarantee of resources inhibits students' innovative behavior significantly and shows obvious disciplinary differences. These findings are consistent with those in Richardson and Mishra's³⁵ study. They found that factors such as mentor and resource support were key influential factors in student innovation. A plays an essential role in supporting student innovation. Further, it contributes significantly to innovative outcomes and the effect is discipline-heterogeneous. The empirical results of this paper support the conclusion of Richardson and Mishra's³⁵ study to a certain extent. However, guaranteed resources have an opposite effect on science and liberal arts students' innovative behavior, which differs from Fidan and Oztürk's⁴¹ finding that that guaranteed resources, such as adequate funding, may encourage innovative behavior, although this result is attributable to disciplinary differences. This study confirms that knowledge sharing affects students' innovative behavior significantly and exhibits disciplinary and regional heterogeneity. There are still disagreements with respect to the association between knowledge sharing and innovative behavior. Our results indicate that knowledge sharing in the form of fellow students' participation is related positively and significantly to innovative behavior. This finding is consistent with that of Pian et al⁴² and Rafique et al.⁴³ Conversely, knowledge sharing in the form of participation in trainings has a negative effect on innovative results, which contradicts the findings of Usmanova et al, who found no significant association between knowledge sharing and innovative behavior.⁴⁴ Potential reasons for this is that some students may choose to give up after they understand scientific and technological innovative activities further through communication and sharing, which thus inhibits innovative behavior. This finding is another important contribution to the literature on innovative behavior, suggesting that knowledge sharing inhibits innovative behavior somewhat.

Second, this study explored personal motivation's significant effect on students' innovative behavior. Intrinsic motivation does not help students achieve innovative results, which differs from previous studies that concluded that intrinsic motivation is a predictor of innovative behavior and has a significant positive motivational effect on such behavior.⁴⁵⁻⁴⁷ This implies that the transformation of motivation into results requires certain conditions. Intrinsic motivation is a necessary, but not sufficient, condition for innovative achievements, as it also requires students' efforts and implementation, while extrinsic motivation plays a positive role, which is inconsistent with Li et al's conclusion that

extrinsic motivation affects creativity negatively by reducing intrinsic motivation.⁴⁸ The influence of intrinsic and extrinsic motivation on students' innovative behavior has obvious disciplinary heterogeneity and regional heterogeneity. Our study responds to several scholars' call for the importance of allocating greater research attention to the relation between personal motivation and innovative behavior.^{49,50}

Third, the study enriches the research on students' innovative behavior by exploring the way students' basic attributes influence innovative behavior. Students' personal and family situations have different effects on their innovative behavior. Compared with multi-child families, students from one-child families are more likely to achieve innovative results, and liberal arts students and students from the Western region also show this characteristic. Having experience of student cadres is often not conducive to obtaining innovative results, and this feature is also reflected in liberal arts students and students from the Western region.

Practical Significance

The study has practical managerial implications for universities, colleges, and organizations to increase students' innovative awareness and ability by promoting the reform of innovative and entrepreneurship education in colleges and universities, and enhancing the high-quality development of innovation and entrepreneurship.

Firstly, universities should provide resources for students, create a good academic atmosphere, and establish a knowledge sharing system. Financial support for students' scientific and technological innovative activities must be provided, and laboratories must be arranged reasonably for student's research needs. It is also important to improve students' basic academic ability by inviting experts to give academic reports regularly, and developing curricula on writing papers and technical methods. School administrators should not only stimulate students' interest in, and enthusiasm for, scientific research, but also help them truly understand the way to achieve science and technology innovative activities by integrating on- and off-campus resources, establishing an academic exchange platform, and providing academic exchanges across universities, disciplines, and grades. At the same time, it is necessary to evaluate mentors and the effect of scientific and technological innovative activities timely, and encourage students to attend graduate school.

Secondly, the instructor should play a strong guiding role and encourage students to participate in their mentors' projects, provide them with basic academic training, and conduct regular academic exchanges by establishing a mentor group.

Finally, students need to make academic plans. Those who are interested should participate in scientific and technological activities as early as possible and coordinate the time between course studies and innovative activities. Further, they should communicate actively with their teachers and focus on cultivating team awareness.

Research Limitations and Recommendations for Future Research

This study had three major limitations. First, it was a cross-sectional study, which did not allow us to capture the effects of personal motivation and innovative climate on innovative behavior at different points in time. Future research should adopt longitudinal methods to complement and extend our findings. The sample size may not be comprehensive, as it covers only several colleges and universities, which increases the potential for error in the data and does not allow this study's results to be generalized. Future research needs to expand the scope and number of samples, and conduct research in different types of universities.

Second, this study takes undergraduates as the research subjects largely, which ignores postgraduates, one of the main scientific research groups in universities. In future work, a comparative study on the influential factors in undergraduates and postgraduates' innovative behaviors can be performed. In addition, mentors' important role in promoting students' innovative behaviors is overlooked easily, and therefore, their guiding role should be valued.

Third, innovative behavior has multiple dimensions, and this study explores only the influence of personal motivation and innovative climate on students' innovative achievements, which represents innovative behavior without giving attention to creative performance and innovative action. This can reflect only one aspect of innovative behavior, which did not allow us to capture the features of innovative behavior fully overall. Further, personal motivation and innovative climate may have different influences on individual innovative behaviors in different dimensions. Subsequent research may consider factors that influence creative performance and innovative action.

This study introduced personal motivation and innovative climate into the analysis framework of students' innovative behavior, which revealed only the tip of the iceberg of the mechanism of the effect of students' innovative behavior. Subsequent research can introduce mediating and moderating variables to analyze the influencing path of personal motivation and innovative climate on students' innovative behavior to enrich the theory of innovative behavior. For example, social capital⁵¹ or mental health.⁵²

Data Sharing Statement

Data supporting the findings of this study are available from the first author, Dr. Qiwen Dai (email: sxsfdx520@163.com).

Ethical Approval

This study was conducted in accordance with the Declaration of Helsinki, and the study has been reviewed and approved by the ethics committee of Guangxi Normal University. All participants read and signed a consent form before they participated in the study.

Acknowledgments

This work was supported financially by the National Natural Science Foundation of China (42061027); the Science and Technology Plan Foundation of Guangxi (Guike AD20159071); the Philosophy and Social Science Planning Foundation of Guangxi (20CJY004); the Degree and Graduate Education Reform Foundation of Guangxi Normal University (XJGY2021015); Guangxi Educational Science "14th Five-Year Plan" Special Project for 2021, Empirical Research on the Influence of Teacher Characteristics on University students' Innovative Ability (2021ZJY1526); Project of Guangxi Social Science Think Tank in 2022 (Zkzxkt202208).

Disclosure

The authors report no conflicts of interest in this work.

References

1. Kör B, Wakkee I, Van der Sijde P. How to promote managers' innovative behavior at work: individual factors and perceptions. *Technovation*. 2021;99:102127. doi:10.1016/j.technovation.2020.1021
2. Zhu YF, Liu JL, Lin S, Liang KX. Unlock the potential of regional innovation environment: the promotion of innovative behavior from the career perspective. *J Innov Knowl*. 2022;7(3):100206. doi:10.1016/j.jik.2022.100206
3. Weng XJ, Chiu TKF, Tsang CC. Promoting student creativity and entrepreneurship through real-world problem-based maker education. *Think Skills Creat*. 2022;45:101046. doi:10.1016/j.tsc.2022.101046
4. Newman A, Tse HHM, Schwarz G, Nielsen I. The effects of employees' creative self-efficacy on innovative behavior: the role of entrepreneurial leadership. *J Bus Res*. 2018;89:1–9. doi:10.1016/j.jbusres.2018.04.001
5. Chen YH, Zhang JM, Liu CE, Liu TT, He W. Work-related identity discrepancy and employee innovation behavior: the role of intrinsic motivation and self-construal. *Chinese Manag Stud*. 2021;15(5):1143–1156. doi:10.1108/cms-02-2021-0051
6. Ye P, Liu LQ, Tan J. Influence of knowledge sharing, innovation passion and absorptive capacity on innovation behaviour in China. *J Org Chang Manag*. 2021;34(5):894–916. doi:10.1108/jocm-08-2020-0237
7. Ye PH, Liu LQ, Tan J. Creative leadership, innovation climate and innovation behaviour: the moderating role of knowledge sharing in management. *Eur J Innov Manag*. 2022;25(4):1092–1114. doi:10.1108/ejim-05-2020-0199
8. Soleas EK. Leader strategies for motivating innovation in individuals: a systematic review. *Int J Entrepreneurship Innov*. 2020;9(1):1–28. doi:10.1186/s13731-020-00120-w
9. Frey K, Lüthje C, Haag S. Whom should firms attract to open innovation platforms? The role of knowledge diversity and motivation. *Long Range Plann*. 2011;44(5):397–420. doi:10.1016/j.lrp.2011.09.006
10. Li GP, Wang XY, Wu JH. How scientific researchers form green innovation behavior: an empirical analysis of China's enterprises. *Technol Soc*. 2019;56:134–146. doi:10.1016/j.techsoc.2018.09.012
11. Zastempowski M, Cyfert S. Impact of entrepreneur's gender on innovation activities. The perspective of small businesses. *PLoS One*. 2021;16(10):e0258661. doi:10.1371/journal.pone.0258661
12. van der Rijst R, Baggen Y, Sjoer E. University teachers' learning paths during technological innovation in education. *Int J Acad Dev*. 2019;24(1):7–20. doi:10.1080/1360144x.2018.1500916
13. Liu MJ, Yu XY. Assessing awareness of college student startup entrepreneurs toward mass entrepreneurship and innovation from the perspective of educational psychology. *Front Psychol*. 2021;12:690690. doi:10.3389/fpsyg.2021.690690
14. Sudibjo N, Prameswari RK. The effects of knowledge sharing and person-organization fit on the relationship between transformational leadership on innovative work behavior. *Heliyon*. 2021;7(6):e07334. doi:10.1016/j.heliyon.2021.e07334

15. Tang Y, Shao Y-F, Chen Y-J. Assessing the mediation mechanism of job satisfaction and organizational commitment on innovative behavior: the perspective of psychological capital. *Front Psychol.* 2019;10:2699. doi:10.3389/fpsyg.2019.02699
16. Gupta V. Relationships between leadership, motivation and employee-level innovation: evidence from India. *Pers Rev.* 2020;49(7):1363–1379. doi:10.1108/pr-11-2019-0595
17. Ryan RM, Deci EL. Intrinsic and extrinsic motivations: classic definitions and new directions. *Contemp Educ Psychol.* 2000;25(1):54–67. doi:10.1006/ceps.1999.1020
18. Deci EL, Ryan RM. Facilitating optimal motivation and psychological well-being across life's domains. *Can Psychol.* 2008;49(1):14–23. doi:10.1037/0708-5591.49.1.14
19. Deci EL, Ryan RM. The “What” and “Why” of goal pursuits: human needs and the self-determination of behavior. *Psychol Inq.* 2000;11(4):227–268. doi:10.1207/s15327965pli1104_01
20. Schmidhuber L, Piller F, Bogers M, Hilgers D. Citizen participation in public administration: investigating open government for social innovation. *R D Manag.* 2019;49(3):343–355. doi:10.1111/radm.12365
21. Li W, Bhutto TA, Xuhui W, Maitlo Q, Zafar AU, Ahmed Bhutto N. Unlocking employees' green creativity: the effects of green transformational leadership, green intrinsic, and extrinsic motivation. *J Clean Prod.* 2020;255:120229. doi:10.1016/j.jclepro.2020.120229
22. Aleksić D, Rangus K, Gomezel AS. Microfoundations of SME open innovation: the role of help, knowledge sharing and hiding. *Eur J Innov Manag.* 2022;25(6):178–203. doi:10.1108/EJIM-10-2020-0411
23. Meyer RD, Dalal RS, Hermida R. A review and synthesis of situational strength in the organizational sciences. *J Manage.* 2010;36(1):121–140. doi:10.1177/0149206309349309
24. He P-X, Wu T-J, Zhao H-D, Yang Y. How to motivate employees for sustained innovation behavior in job stressors? A cross-level analysis of organizational innovation climate. *Int J Environ Res Public Health.* 2019;16(23):4608. doi:10.3390/ijerph16234608
25. Shanker R, Bhanugopan R, van der Heijden BIJM, Farrell M. Organizational climate for innovation and organizational performance: the mediating effect of innovative work behavior. *J Vocat Behav.* 2017;100:67–77. doi:10.1016/j.jvb.2017.02.004
26. Park S, Jo SJ. The impact of proactivity, leader-member exchange, and climate for innovation on innovative behavior in the Korean government sector. *Leadersh Organ Dev J.* 2018;39(1):130–149. doi:10.1108/lodj-09-2016-0216
27. Soares ME, Mosquera P, Cid M. Antecedents of innovative behaviour: knowledge sharing, open innovation climate and internal communication. *Int J Innov.* 2021;30(2):241–257. doi:10.1504/ijil.2021.117223
28. Binard C, Pohl S. Self-efficacy, cognitive flexibility and climate of the support of innovation as antecedents of the innovative behavior. *Psychol du Trav et des Organ.* 2013;19(4):420–435. doi:10.1016/s1420-2530(16)30052-8
29. Liu F, Chow IHS, Zhang JC, Huang M. Organizational innovation climate and individual innovative behavior: exploring the moderating effects of psychological ownership and psychological empowerment. *Rev Manag Sci.* 2019;13(4):771–789. doi:10.1007/s11846-017-0263-y
30. Yesil S, Dogan IF. Exploring the relationship between social capital, innovation capability and innovation. *Creativity Innov Manag.* 2019;21(4):506–532. doi:10.1080/14479338.2019.1585187
31. Zhang C, Chen C. The effect of Zhong-yong thinking to employee survival ability: taking Chinese employees as an example. *Int J Sociol Soc Policy.* 2020;40(11/12):1319–1336. doi:10.1108/IJSSP-02-2020-0038
32. De Jong J, den Hartog D. Measuring innovative work behaviour. *Creativity Innov Manag.* 2010;19(1):23–36. doi:10.1111/j.1467-8691.2010.00547.x
33. Scott SG, Bruce RA. Determinants of innovative behavior: a path model of individual innovation in the workplace. *Acad Manag J.* 1994;37(3):580–607. doi:10.5465/256701
34. Portillo EC, Rothbauer K, Meyer J, et al. Impact of a novel project management course sequence on innovative thinking in pharmacy students. *Curr Pharm Teach Learn.* 2021;13(8):982–991. doi:10.1016/j.cptl.2021.06.005
35. Richardson C, Mishra P. Learning environments that support student creativity: developing the SCALE. *Think Skills Creat.* 2018;27:45–54. doi:10.1016/j.tsc.2017.11.004
36. Amabile TM, Hill KG, Hennessey BA, Tighe EM. The work preference inventory: assessing intrinsic and extrinsic motivational orientations. *J Pers Soc Psychol.* 1994;66(5):950–967. doi:10.1037/0022-3514.66.5.950
37. Ramsey JR, Lorenz MP. Exploring the impact of cross-cultural management education on cultural intelligence, student satisfaction, and commitment. *Acad Manag Learn Educ.* 2016;15(1):79–99. doi:10.5465/amle.2014.0124
38. Tu XY, Wang ZY, He X, Zhang Q. Critical thinking, creative process engagement and innovation behavior: the empirical study of Technology-Based enterprises. *Sci Technol Built Environ.* 2017;38(3):126–138.
39. Shen YJ, Xie WX, Wang XY, et al. Impact of innovative education on the professionalism of undergraduate nursing students in China. *Nurse Educ Today.* 2020;98:104647. doi:10.1016/j.nedt.2020.104647
40. Deng BJ, Cao JJ, Huang JQ, Wu J. The influence of innovation climate on creative role identity: the mediating role of flow. *Front Psychol.* 2022;13:866464. doi:10.3389/fpsyg.2022.866464
41. Fidan T, Oztürk I. The relationship of the creativity of public and private school teachers to their intrinsic motivation and the school climate for innovation. *Procedia.* 2015;195:905–914. doi:10.1016/j.sbspro.2015.06.370
42. Pian QY, Jin H, Li H. Linking knowledge sharing to innovative behavior: the moderating role of collectivism. *J Knowl Manag.* 2019;23(8):1652–1672. doi:10.1108/jkm-12-2018-0753
43. Rafique MA, Hou YM, Chudhery MAZ, Waheed M, Zia T, Chan FZ. Investigating the impact of pandemic job stress and transformational leadership on innovative work behavior: the mediating and moderating role of knowledge sharing. *J Innov Knowl.* 2022;7(3):100214. doi:10.1016/j.jik.2022.100214
44. Usmanova N, Yang J, Sumarliah E, Khan SU, Khan SZ. Impact of knowledge sharing on job satisfaction and innovative work behavior: the moderating role of motivating language. *VINE J Inf Knowl Manag Syst.* 2020;51(3):515–532. doi:10.1108/VJKMS-11-2019-0177
45. Klaeijsen A, Vermeulen M, Martens R. Teachers' innovative behaviour: the importance of basic psychological need satisfaction, intrinsic motivation, and occupational self-efficacy. *Scand J Educ Res.* 2017;62(5):769–782. doi:10.1080/00313831.2017.1306803
46. Rahrovani Y, Pinsonneault A. Innovative IT use and innovating with IT: a study of the motivational antecedents of two different types of innovative behaviors. *J Assoc Inf Sci Technol.* 2020;21(4):936–970. doi:10.17705/1jais.00625
47. Hussain TB, Zhang Y. The influences of cross-cultural adjustment and motivation on self-initiated expatriates' innovative work behavior. *Pers Rev.* 2022;51. doi:10.1108/PR-05-2021-0320

48. Li WJ, Bhutto TA, Wang XH, Maitlo Q, Zafar AU, Bhutto NA. Unlocking employees' green creativity: the effects of green transformational leadership, green intrinsic, and extrinsic motivation. *J Clean Prod.* 2020;255:120229. doi:10.1016/j.jclepro.2020.120229
49. Montani F, Courcy F, Battistelli A, de Witte H. Job insecurity and innovative work behaviour: a moderated mediation model of intrinsic motivation and trait mindfulness. *Stress Health.* 2021;37(4):742–754. doi:10.1002/smi.3034
50. Kim TT, Lee G. Hospitality employee knowledge-sharing behaviors in the relationship between goal orientations and service innovative behavior. *Int J Hosp Manag.* 2013;34:324–337. doi:10.1016/j.ijhm.2013.04.009
51. Zhang C, Liu L. The effect of job crafting to job performance. *Knowl Manag Res Pra.* 2021;19(2):253–262. doi:10.1080/14778238.2020.1762517
52. Liu L, Zhang C, Fang C-C. Effects of health-promoting leadership, employee health on employee engagement: employability as moderating variable. *Int J Workplace Health Manag.* 2022;15(1):1–18. doi:10.1108/IJWHM-07-2020-0122

Psychology Research and Behavior Management

Dovepress

Publish your work in this journal

Psychology Research and Behavior Management is an international, peer-reviewed, open access journal focusing on the science of psychology and its application in behavior management to develop improved outcomes in the clinical, educational, sports and business arenas. Specific topics covered in the journal include: Neuroscience, memory and decision making; Behavior modification and management; Clinical applications; Business and sports performance management; Social and developmental studies; Animal studies. The manuscript management system is completely online and includes a very quick and fair peer-review system, which is all easy to use. Visit <http://www.dovepress.com/testimonials.php> to read real quotes from published authors.

Submit your manuscript here: <https://www.dovepress.com/psychology-research-and-behavior-management-journal>