

A THERMODYNAMIC ANALYSIS OF MITOTIC SPINDLE EQUILIBRIUM AT ACTIVE METAPHASE

R. E. STEPHENS

From The Marine Biological Laboratory, Woods Hole, Massachusetts 02543, and The Department of Biology, Brandeis University, Waltham, Massachusetts 02154

ABSTRACT

The mitotic apparatus of first-division metaphase eggs of the sea urchin *Strongylocentrotus drobachiensis* was observed by means of polarization microscopy under controlled temperature conditions. Eggs were fertilized and grown at two temperature extremes in order to produce two different sizes of available spindle pool. Slow division time allowed successive samples of such cells to be observed at the same point in metaphase but at different equilibrium temperatures, yielding curves of metaphase equilibrium birefringence vs. observational temperature. Using the plateau value of birefringence at higher temperatures as a measure of total available spindle pool and the observed birefringence at lower temperatures as a measure of polymerized material at equilibrium, the spindle protein association was evaluated according to the method of Inoué. Both pool conditions produced linear van't Hoff functions. Analysis of these functions yielded enthalpy and entropy changes of +55–65 kcal/mol and +197–233 entropy units (eu), respectively. These values for active mitotic metaphase are quite comparable to those obtained by Inoué and co-workers for arrested meiotic metaphase cells. When other equilibrium treatments were considered, the best fit to the experimental data was still that of Inoué, a treatment which theoretically involves first-order polymerization and dissociation kinetics. Treatment of metaphase cells with D₂O by direct immersion drove the equilibrium to completion regardless of temperature, attaining or exceeding a birefringence value equal to the cell's characteristic pool size; perfusion with D₂O appeared to erase the original temperature-determined pool size differences for the two growth conditions, attaining a maximum value characteristic of the larger pool condition. These data confirm Inoué's earlier contention that D₂O treatment can modify the available spindle pool.

INTRODUCTION

The labile nature of spindle fibers has long intrigued many investigators. The mere existence of such fibers was a matter of some debate until Inoué (1953), using high extinction polarization microscopy, clearly demonstrated their presence in living cells. During this same period, Inoué discovered that spindle fibers could be reversibly abolished by the antimetabolic drug colchicine (Inoué, 1952 *a*) and by hypothermic treatment (Inoué, 1952 *b*). This latter effect has been used

to advantage in investigating the temperature-dependent equilibrium that spindle fibers appear to undergo.

Increase in temperature caused an increase in birefringence, the value of which asymptotically approached an upper limit as the temperature was raised further. Through the use of this upper limit as an estimate of the total available pool of spindle monomer, coupled with the fiber birefringence as a measure of oriented material, an

equilibrium constant could be calculated at any given observational temperature. With the proper choice of an upper limit, the log of this constant was linear with reciprocal absolute temperature. From the van't Hoff relationship, a value for ΔH was then computed and from this, in turn, ΔS was obtained from the second law. The initial thermodynamic studies were carried out on *Chaetopterus* oocytes, giving values of +28 kcal and +98 eu for changes in enthalpy and entropy of association, respectively (Inoué, 1959, 1964). Later studies, involving observations of living meiotic metaphase spindles in *Pectinaria* oocytes (Carolan et al., 1965, 1966) and in vitro spindles isolated at various temperatures from *Pisaster* oocytes (Sato and Bryan, 1968), yielded parameters which were roughly twice these values. Because of the similarity of such thermodynamics to those for the association of tobacco mosaic virus (TMV) A-protein or G-ADP-actin, Inoué and collaborators interpreted spindle fiber equilibrium in terms of hydrophobic or entropic bonding, relating the high positive entropy change to the disordering of many moles of protein-associated structured water as a spindle fiber protein monomer takes an ordered position in the fibrous polymer (Inoué, 1964; Inoué and Sato, 1967).

By means of a slow colchicine-induced spindle fiber depolymerization, Inoué (1952 *a*) was able to observe chromosome movement toward an attached pole; by application of D_2O to the spindle, he found that birefringence was enhanced and was accompanied by a marked increase in spindle volume and interpolar distance (Inoué and Sato, 1967). This apparent pulling or pushing via labile association or dissociation of spindle fiber monomers, coupled with the thermodynamic equilibrium discussed above, gave rise to the "dynamic equilibrium" theory of mitotic movement whereby chromosomes were initially positioned and then later separated by oriented local sequences of polymerization and depolymerization (Inoué, 1964; Inoué and Sato, 1967).

Six major criticisms can be leveled at this general model for mitotic spindle function, nearly all related either to the methodology or to the mathematics used to obtain equilibrium data. First, spindle fiber birefringence may be the result of a multitude of proteins, not just that of the spindle microtubule as assumed by the Inoué model. This point applies not only to the validity of the observed changes in birefringence

but also to the appropriateness of a simple one-step polymerization. Secondly, application of D_2O not only increased spindle fiber birefringence but also changed the limiting birefringence of the equilibrium function, implying a change in the monomer pool size, a parameter assumed constant under the Inoué treatment. Thirdly, the linearity of the van't Hoff relationship was dependent upon a subjective choice of an upper limit of birefringence and an adequate approximation of the equilibrium curve. Fourthly, the polymerization theoretically should involve addition of monomer to existing polymer, yielding a higher polymer, a process whose association step should show second-order kinetics and whose equilibrium constant is explicit, i.e. has units of concentration, a fact which requires evaluation of molar concentrations in order to determine meaningful free energy changes. Fifthly, any simple mechanism by which chromosomes are moved by growth or disappearance of spindle fibers intuitively seems to violate simple newtonian mechanics, particularly since spindle fibers are generally considered to be internally rigid structures and presumably not amenable to addition or removal of subunits except at either end. Finally, nearly all thermodynamic data were obtained from metaphase-arrested oocytes, as were the colchicine and D_2O -induced spindle fiber length changes; the observed equilibrium may simply reflect the arrested state and bear no resemblance to active metaphase.

Two of these objections appear now to be no longer significant. The direct relationship between spindle fiber birefringence and either microtubule number or polymerized tubulin content has recently been determined (Sato et al., 1971; Stephens, 1971, 1972 *b*), while an experimentally induced but natural variation in pool size, resulting from environmental temperature during prophase, has been demonstrated in sea urchin eggs grown at several temperatures (Stephens, 1972 *b*). Birefringence is proportional to microtubule or tubulin content and can be theoretically accounted for totally. A variation in pool would actually be necessary for the dynamic equilibrium model, since a spindle must be assembled and disassembled by a reaction whose equilibrium constant must remain constant. However, the validity of a simple monomer-polymer equilibrium still depends heavily on an unequivocal evaluation of the equilibrium function. In this regard, pre-

liminary evidence indicates that polymerization and depolymerization of *Pisaster* meiotic metaphase spindles follow first-order kinetics (Sato and Bryan, 1968), just as the Inoué equilibrium formulation would predict.

Observations made on mitosis at low temperature may prove useful in understanding spindle equilibrium, particularly at active metaphase. In the sea urchin *S. droebachiensis*, fertilized eggs function normally over a temperature range of -1 to $+9^{\circ}\text{C}$, utilize a pool of available spindle monomer nearly twice as large at the upper temperature, and divide in about 9 h at 0°C and in 3 h at 8°C (Stephens, 1972 *a, b*). A reanalysis of the Inoué thermodynamic treatment in this organism would have several unique advantages. The long division time should allow accurate determination of spindle birefringence at active metaphase for any chosen temperature, the induced variation in pool size should permit evaluation of thermodynamic parameters at different limiting values of birefringence, and the low natural equilibrium temperature range should allow direct experimental determination of this upper limit without complications from denaturation or depolymerization. Do the data fit the simplistic equilibrium treatment of Inoué, or is a more complex treatment, based for example on linear condensation polymerization, needed for good fit? Are the resulting thermodynamic parameters comparable when the effective pool is varied? Do these values agree in sign and magnitude with those found previously for quite different organisms functioning at substantially higher temperature ranges? Can D_2O effects be explained in terms of equilibrium shifts and changes in apparent pool sizes?

MATERIALS AND METHODS

Experimental Material

The sea urchin *S. droebachiensis* was obtained from shallow subtidal areas of Cape Cod Bay and maintained in a running seawater system at $2-4^{\circ}\text{C}$. Gametes were obtained and handled as described in detail elsewhere (Stephens, 1972 *a, b*). Only egg batches showing at least 95% fertilization and dividing at either 190 ± 5 min at 8°C or 510 ± 15 min at 0°C were used. These studies were carried out during early and midseason (January through March, 1971-1972) to avoid variations both in synchrony and in spindle birefringence, which are often characteristic of the late portion of the breeding season.

One group of 24 animals was artificially ripened several months before the natural season by placing the unripe urchins in a refrigerated aquarium at $+1^{\circ}\text{C}$ and feeding them *Laminaria* and *Ascophyllum*. Within 4 wk, a near-normal degree of gonad development took place. Behavior of fertilized eggs obtained from these animals was essentially identical with that from the normally developing population.

Experimental Protocol

10-12 samples, containing 0.2 ml of eggs in 2 ml of seawater, were fertilized in "honeycombed" scintillation vials at successive 5 min intervals and grown to metaphase at either 0°C on ice or at 8°C in a water bath. Samples of these portions were removed either at 145 min at 8°C or at 400 min at 0°C (i.e. 5 min before scheduled metaphase; see Stephens, 1972 *a*) and immediately placed on a temperature-regulated slide. After 2 min equilibration time, the metaphase spindle birefringence was read for 4-10 cells in each sample. The temperature was then changed, a sample of the next portion taken, and additional birefringence values determined. The result of such a protocol was a record of metaphase spindle birefringence over a $10-20^{\circ}\text{C}$ temperature range at $1-2^{\circ}\text{C}$ intervals for samples of the same set of cells at precisely the same point in the cell cycle. Temperature spans were chosen to cover the range of -2° to $+28^{\circ}\text{C}$ for cells grown at either 0 or 8°C . A total of over 600 independent measurements were made in each case, using cells from six separate females.

Optical Equipment and

Retardation Measurement

Measurements were made with a Leitz Ortholux Pol polarizing microscope equipped with a xenon light source, heat-absorbing and 546 nm narrow band-pass interference filters, and selected strain-free lenses (E. Leitz, Inc., Rockleigh, N. J.). A Brace-Koehler rotating mica compensator of 18 nm retardation (E. Leitz, Inc.) was used to measure chromosomal spindle fiber birefringence. The polar axis of the mitotic apparatus was rotated to a point 45° with respect to the polarizer-analyzer axis, the immediate background was brought to extinction, the spindle fibers were brought to extinction (but not to maximum contrast), and the difference in compensator angles between the two conditions (θ) was used to determine retardation in accord with the formula $r_T = r_{\text{comp}} \sin 2\theta$, where r_T is the retardation of the fibers at temperature T and r_{comp} is the retardation of the compensator. Such a measurement reflects the amount of oriented material per unit volume; since all microtubules are essentially parallel in the central spindle region, this parameter should be a direct function of polymer concentration (cf. Sato et al., 1971).

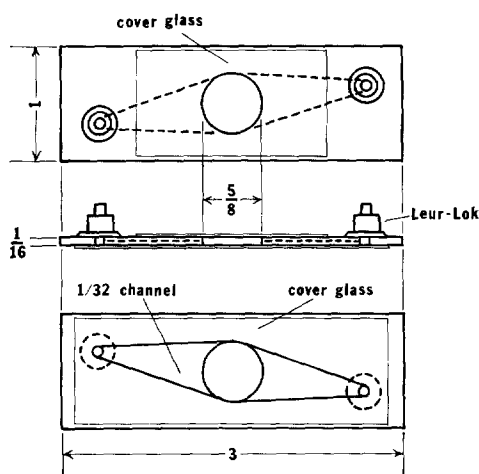

FIGURE 1 Temperature control slide. Top, side, and bottom views. Dimensions in inches.

Temperature Control

In principle, the apparatus setup followed the basic designs of Inoué et al. (1970), but because it represents some basic and practical simplifications it will be described in detail. A 1×3 inch sheet of $\frac{1}{16}$ inch aluminum stock was milled to a depth of $\frac{1}{32}$ inch to produce a channel lengthwise across the slide, connecting $\frac{1}{16}$ -inch-diameter inlet and outlet holes and intersecting a $\frac{5}{8}$ inch viewing hole at the slide center. Large no. 1 cover glass was cut to cover all holes on the slide bottom but only the center (viewing) hole on the top. These glass pieces were cemented to the aluminum with General Electric "Silicone Seal" (General Electric Co., Silicone Products Dept., Waterford, N. Y.) while two Leur-Lok syringe fittings were attached to the inlet and outlet holes with epoxy-resin. This produced a cover glass-metal slide-cover glass sandwich through which water could easily flow and which had approximately the same linear dimensions and thickness as a standard microscope slide (Figs. 1 and 2 A). The slide was insulated from the stage by means of a sheet of $\frac{1}{32}$ inch polyethylene.

Water from two vessels, one at 30°C and the other at 0°C , was mixed through the use of two two-way aquarium air valves connected together valve stem to valve stem, one full turn out of phase. The outlets were run through a three-way valve of similar design to allow mixing and flow regulation. The result of this setup is a constant volume, constant pressure mixing system, permitting selection of temperature by simple rotation of the connected valve stems (Fig. 2 B). To minimize heat loss or gain, thick-walled Tygon tubing was used for all connections except those at the slide itself, where flexibility is needed for stage rotation. For

temperatures below about 3°C , cold water at 10°C and 30% methanol at -20°C were substituted for the iced and warm water baths. A flow rate of 4 liters/h was maintained to assure adequate temperature equilibration and stabilization.

Temperature was measured by the use of Yellow Springs Instrument Co. (YSI) (Yellow Springs, Ohio) Model 403 bead-tipped thermistor probes mounted in brass "T" tubes in the inlet and outlet tubing of the temperature slide (Fig. 2 C), monitored with a YSI Model 43TD "Tele-Thermometer" and appropriate junction box. The specimen temperature was taken as the mean of the influx and efflux temperatures, values which differed by 0.4°C at most at the highest and lowest temperature points. The actual surface temperature, measured under operating conditions, was within $\pm 0.1^{\circ}\text{C}$ of this average value, as determined directly with a YSI Model 421 surface temperature thermistor probe. "Frosting" was prevented by a very thin film of Kodak Photo-Flo (Eastman Kodak Co., Rochester, N. Y.) on top of the preparation cover slip and on the underside of the control slide cover glass.

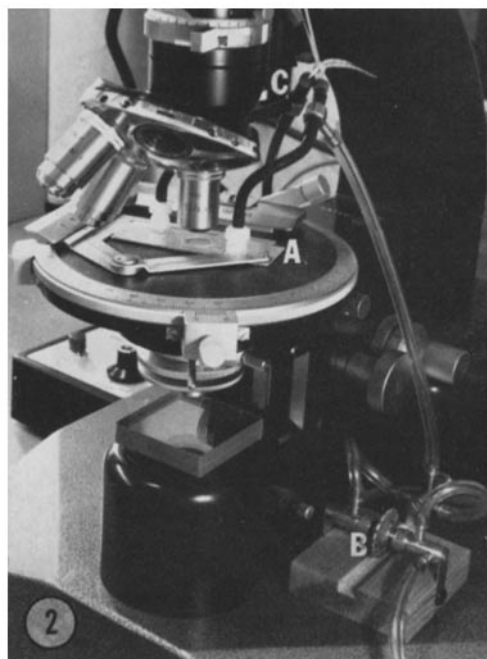

FIGURE 2 Polarizing microscope, temperature control slide, and constant-pressure mixing valve. The slide is shown at A and is normally separated from the rotating stage by a sheet of $\frac{1}{32}$ inch polyethylene sheet as insulation, here removed for this photograph. The rotating valve stems are illustrated at B, the thermistors at C.

Data Treatment

Retardation values for each experimental temperature (i.e., from 4 to 10 measurements) were averaged and plotted against temperature for cells grown at either 0 or 8°C. Replicate measurements agreed within $\pm 7\%$, while different eggs within the same sample agreed within about $\pm 15\%$, both percentages representing the range from the mean. No points were discarded. All retardation values above 12°C were averaged to establish an experimental "upper limit" since, under both growth conditions, a retardation plateau was reached at this temperature with no sign of decrease at higher temperatures. Each averaged experimental point was used to calculate an apparent equilibrium constant (k_T) at its respective temperature, according to the relationship $k_T = b/(A_0 - b)$, where A_0 is the upper limit of maximum birefringence or pool and b is the observed birefringence of oriented material at temperature T . (Inoué, 1964). The log of each of these constants was then plotted against reciprocal absolute temperature ($1/^\circ\text{K}$) and a line was placed through the resultant points by the method of least squares. The slope of this function was then used in the van't Hoff relationship, $d \ln K/dT = \Delta H/RT^2$, to determine ΔH . The change in entropy, ΔS , was calculated at $\Delta G = 0$ (i.e., the temperature at which $k_T = 1$) from the relationship $\Delta G = \Delta H - T\Delta S$, thus requiring no direct determination of ΔG .

This treatment makes no assumptions about the value of A_0 , carries all experimental points through to

the final van't Hoff plot, and thus makes no assumptions about the shape of the equilibrium curve, and, finally, it uses the method of least squares to test the applicability of the van't Hoff relationship to the unadjusted data. Linear regression, standard error, and significance computation were carried out in accordance with standard statistical procedures (Bailey, 1966).

RESULTS

Birefringence Changes during the Time-Course of Mitosis

Whether cells are grown at 0 or at 8°C, measurable (astral) birefringence is detectable at nuclear membrane breakdown. Spindle birefringence increases almost uniformly during prophase, plateaus briefly at metaphase, rises rapidly as the chromosomes begin to separate, and then decreases at a nearly constant rate as chromosome movement continues and telophase is reached. These changes are illustrated in Fig. 3, determined as averaged values for at least six cells at each time point. A very slight (10–20%) decrease in birefringence was sometimes noted at late metaphase (cf. Inoué and Sato, 1967), but this has not been illustrated because of its variability.

The relative constancy of birefringence during mid- and late metaphase (10 min at 8°C and

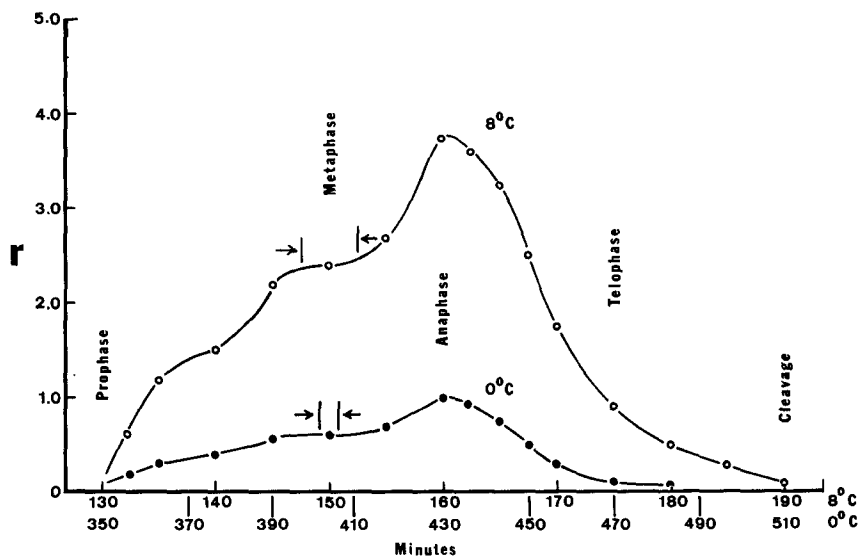

FIGURE 3 Spindle retardation vs. time for cells fertilized and grown at 0 and 8°C. The time spans marked with arrows are the time intervals during which metaphase birefringence was read at various experimental temperatures.

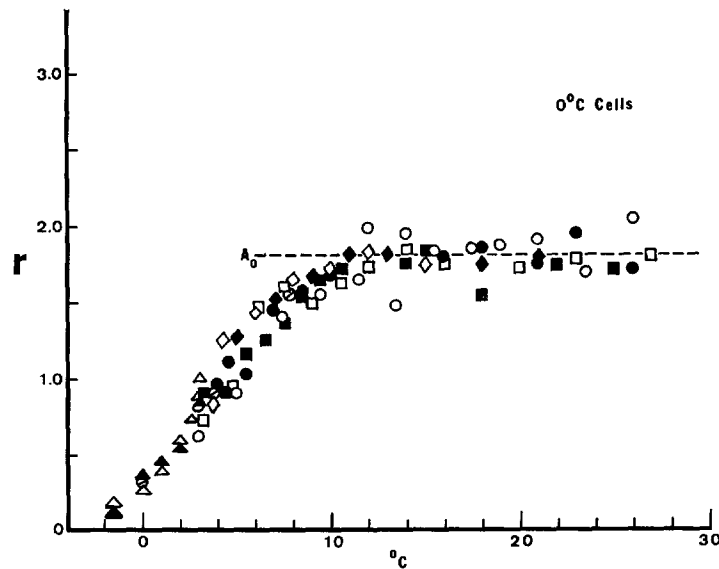

FIGURE 4 Metaphase retardation vs. experimental temperature for cells fertilized and grown at 0°C. Circles are values from eggs of artificially ripened females, squares from eggs of early season females, and diamonds and triangles from eggs of mid-season females. The crossed circles are retardation values from mitotic apparatuses isolated from cells brought to the experimental temperature. Each point represents the average of 4-10 cells at any given time point.

about 25 min at 0°C) in this low temperature organism permits temperature equilibration and several successive retardation measurements during this period. The interval marked on Fig. 3 illustrates this point for the 5 min equilibration-measurement sequence used under the two temperature conditions.

The fact that birefringence is changing markedly throughout most of the stages of mitosis makes this approach unfeasible, or at best only approximate, for measuring temperature equilibrium at points other than metaphase. A reasonable evaluation can be made, however, with respect to the maximum attainable birefringence at any time point. By transferring cells from growth temperature to 20°C, an immediate retardation measurement can be made. For cells at any point up to early anaphase, the birefringence increases three- to fourfold for cells grown at 0°C and from 50 to 70% for those grown at 8°C. After early anaphase, the spindles become much less responsive to temperature increases (though not decreases), implying that after that point there is progressively less spindle protein (i.e., available pool) to utilize in the temperature-driven equilibrium. In fact by late anaphase-

telophase, increased temperature has no measurable effect on the remaining astral birefringence.

Retardation vs. Temperature at Metaphase

Regardless of the magnitude of temperature change, equilibrium (i.e., constancy of birefringence) was reached within 1-2 min, allowing about 3 min for actual metaphase measurements. The birefringence of metaphase spindles in eggs fertilized and grown at 0°C and observed at various other temperatures is given in Fig. 4, while that for cells fertilized and grown at 8°C appears in Fig. 5. Both curves are roughly sigmoid. At temperatures above about 12°C, the 0°C cells attain a limiting retardation (A_0) of 1.81 ± 0.12 nm, as compared with a value of 2.78 ± 0.25 nm for the 8°C cells, the errors being standard deviations for 28 and 27 measurements, respectively. This observation unquestionably supports an earlier contention that cells of this organism grown at higher temperatures have a substantially larger pool of available spindle precursors (Stephens, 1971, 1972 *b*). At the lower end of the temperature scale, the 8°C cells have a retardation of about 0.4 nm at 0°C while the 0°C growth cells have a value of about 0.25 nm

at this same temperature. In fact, these values are only roughly halved as the cells reach the freezing point of the medium, -1.8°C , and then change negligibly as the cells themselves freeze.

The retardation values reported here are, in some cases, about two-thirds of comparable values reported previously (Stephens, 1971, 1972 *b*). There are three basic reasons for this, all of them relevant to birefringence temperature studies in general. In the earlier studies, maximum contrast of the spindle, rather than initial extinction, was measured. This produces a proportionately higher evaluation of retardation, but does not affect any conclusions. Secondly, temperature control was not as precise because of a low flow rate and hence the cells were possibly warmer than recorded. Thirdly, samples were taken late in metaphase and were transferred to higher temperatures for observation or spindle isolation; the cells were close to late metaphase-early anaphase when observed. The latter two factors would produce a falsely high retardation reading, the one high relative to presumed temperature and the other high with respect to the presumed stage of mitosis.

Separate sets of cells, denoted by various symbols, show good agreement and therefore biological variability (e.g., seasonal or female dependent) appears to be minimal. Some of these were determined very early in the season (squares),

some in midseason (diamonds and triangles), and yet others were from artificially ripened females (circles). The crossed circles in Figs. 4 and 5 are retardation values from isolated spindles of eggs grown at either 0 or 8°C and isolated at the specified temperatures by methods described elsewhere (Stephens, 1972 *b*). The agreement of retardation values from spindles *in vitro* with the overall *in vivo* birefringence temperature indicates that, in fact, earlier differences were methodological.

Analysis by the van't Hoff Relationship

Using the experimentally determined A_0 values from Figs. 4 and 5, plus the observed retardations (r_T) from these same figures, $\log k_T$ was determined for each observational temperature and plotted against reciprocal temperature ($1/^{\circ}\text{K}$). The results for the temperature-dependent equilibria of the 0 and 8°C growth conditions are illustrated in Figs. 6 and 7, respectively. Least-square (linear regression) lines have been computed for both sets of data. The coefficients of correlation are 0.97 for the 0°C data and 0.91 for the 8°C case. By inspection, the functions appear to be linear over a range of -1.5 to $11-12^{\circ}\text{C}$, the limits of the range investigated, with some degree of nondirectional scatter in the more mathematically sensitive higher temperature points. No

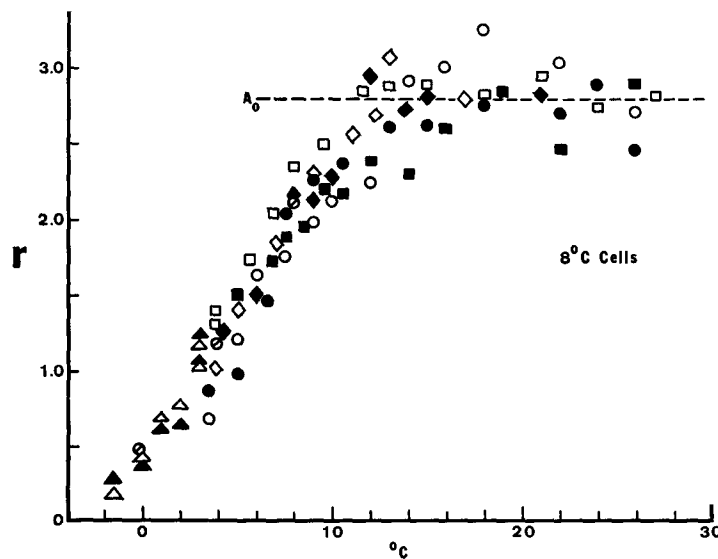

FIGURE 5 Metaphase retardation vs. experimental temperature for cells fertilized and grown at 8°C . Designations are the same as in Fig. 4.

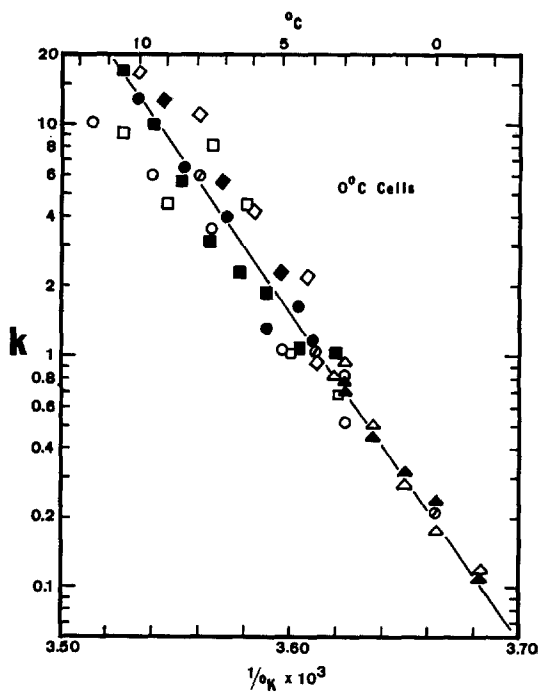

FIGURE 6 Equilibrium constant vs. reciprocal temperature for cells grown at 0°C. Designations are the same as in Fig. 4. The line was determined by the method of least squares (linear regression).

attempt was made to “weight” these latter points to minimize their error. Equal amounts of “monomer” and “polymer” (i.e., $\Delta G = 0$) exist at 4°C for cells grown at 0°C and at about 5°C for cells grown at 8°C. The enthalpy change for association was found to be $+64.5 \pm 2.3$ kcal/mol under the 0°C growth condition and $+54.9 \pm 2.8$ kcal/mol for cells grown at 8°C. The values for ΔS were found to be $+233 \pm 8.2$ eu for cells grown at 0°C and $+197 \pm 10.0$ eu for the 8°C growth condition. The standard error of the regression line was used to establish the error in the enthalpy; the same percentage was then used with respect to the entropy. The difference between the regression functions for the two growth conditions is significant at $P = 0.02$. Though significant on a statistical basis, the differences in the two sets of parameters can be rationalized on experimental rather than theoretical grounds.

Spindles from eggs grown at 0°C, having a smaller pool size, deploy essentially all available material to the central spindle region when temperatures are elevated; at normal growth temperatures they are in fact essentially anastral

(Stephens, 1972 *b*). Since the analysis undertaken here utilizes only central spindle birefringence, the distribution of which changes only very little as temperature is increased, little error would be expected on geometrical grounds in the 0°C case. The 8°C cells, on the other hand, devote part of their inherently larger pool to the formation of asters, the total birefringence of which, for reasons of radial symmetry, cannot be accurately determined. Secondly, the central spindle region changes somewhat in width and length as temperature is increased in the 8°C cells, but it is the retardation per unit area that is actually measured. These two factors would lead to increasing underestimation of the amount of material oriented at any given temperature as the temperature is increased, an underestimation of k_T , and hence to a lower slope and a lower resulting ΔH . In fact, by inspection of Fig. 7 one can note that points below about 4°C could easily fall on the 0°C line of Fig. 6. Adjustment of individual k_T values for dimensional parameters would bring the two temperature conditions more in line, but these corrections require some subjective judgment and

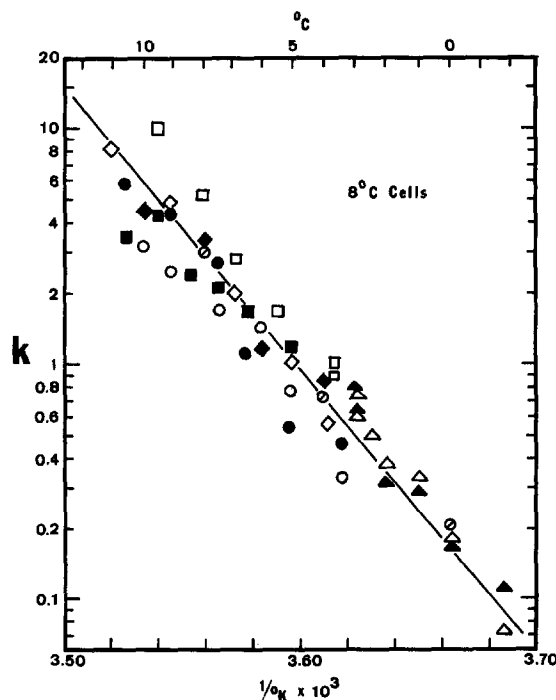

FIGURE 7 Equilibrium constant vs. reciprocal temperature for cells grown at 8°C. Designations are the same as in Fig. 4. Analysis as in Fig. 6.

several geometrical assumptions, none of which are either necessary or desirable for the purposes at hand. Also the value of A_0 was taken as absolute for the data treatment; if one considers the error in this function the differences in enthalpy and entropy values for the two growth temperature conditions become only barely significant.

Alternative Equilibrium Treatments

Although the above van't Hoff functions are linear, the equilibrium constants for the 0 and 8°C growth conditions do differ and the possibility still remains that the simple first-order monomer-polymer equilibrium treatment of Inoué does not actually hold. One simple way of obtaining relative equilibrium equations for alternative treatments consists of equating the forward and reverse kinetic equations for various orders of reaction. Using the basic data of Figs. 4 and 5, a treatment parallel to that used by Smith and Lauffer (1967) for linear condensation polymerization of TMV A-protein can be applied to the mitotic spindle, although use of this treatment is not meant to necessarily imply such a mechanism. Reiterating Smith and Lauffer (1967), if p is taken as the degree of polymerization (here assumed to be b/A_0), the concentration of monomer (in this case dimeric tubulin) in polymeric form will be mp (here b), where m is the total molar concentration of monomer (in this case a direct function of A_0 but not evaluated in molar concentration). The concentration of free monomer at equilibrium z follows as $m(1 - p)$. The thermodynamic equilibrium constant K may be taken as the ratio of the forward and reverse rate constants for polymerization and dissociation, respectively. For TMV A-protein polymerization, Smith and Lauffer (1967) considered the association to be second order, and the dissociation first order, giving $dz/dt = 0$ at equilibrium, or $k_1 m^2 (1 - p)^2 = k_2 mp$, where k_1 and k_2 are the association and dissociation rate constants, respectively. The equilibrium constant K follows as k_1/k_2 and is equal to $p/m(1 - p)^2$, a function directly applicable to the birefringence data and yielding the relationship $K = b/(A_0 - b)^2$. Assuming first-order polymerization and zero-order dissociation, one obtains $k_1/k_2 = 1/m(1 - p)$ or $(A_0 - b)^{-1}$; the reverse situation equates k_1/k_2 to mp , or simply b in terms of spindle birefringence. Least-square polynomials fit to the experimental data treated by these alternative equilibrium equations show

marked nonlinearity in the van't Hoff relationship and have equilibrium constants which are even more disparate for the two pool size conditions. Only the physically unlikely case of a first-order polymerization and a second-order dissociation, where $k_1/k_2 = (mp)^2/m(1 - p)$ or $b^2/(A_0 - b)$, yields equilibrium constants for the 0 and 8°C data which show reasonable agreement. Here too, however, the functions are nonlinear but not nearly as much as in the other test cases. The regression curves for the four alternative equilibrium treatments are illustrated in Fig. 8. It must be borne in mind that the numerical values for these equilibrium constants are only relative ones, useful for comparing the van't Hoff functions for the 0 and 8°C growth or pool conditions; they theoretically should be expressed in terms of molar concentration but are given here in terms of relative A_0 for comparison. It is important to point out that the assumption of first-order forward and reverse reactions yields the relationship $k_1/k_2 = mp/m(1 - p)$, a dimensionless function which reduces directly to the Inoué equilibrium equation, already shown to yield essentially linear van't Hoff relationships with the two sets of experimental data. Thus the model of Inoué (1964) appears to give optimal fit for both the 0 and 8°C data from *S. drobachiensis*, although the exact polymerization mechanism corresponding to these data is at the moment quite uncertain.

The Effect of D₂O

When cells at metaphase were mixed 1:1 with pure D₂O-seawater at the growth temperature, transferred to the temperature slide, equilibrated, and then measured, the resulting birefringence was approximately equal to the limiting birefringence A_0 for the respective growth temperature, regardless of observational temperature (Fig. 9 a). In other words, the equilibrium was driven all the way to completion by D₂O, making impossible any temperature equilibrium analysis. If anything, the retardation values at higher temperatures were lower than those from low temperature conditions, particularly in the case of cells grown at 0°C.

When either 0 or 8°C growth condition cells were perfused at metaphase with 50% D₂O after equilibration at the observational temperature, the maximum retardation approached or exceeded that of the 8°C growth condition, again showing no decrease in birefringence at low temperatures

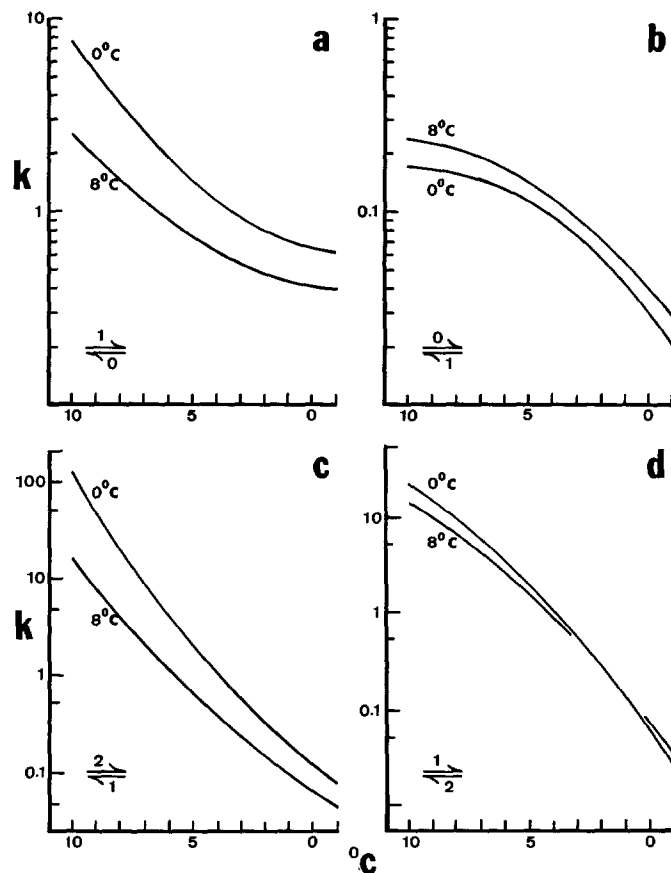

FIGURE 8 Polynomial regression curves of the 0 and 8°C retardation vs. temperature data for various alternative equilibrium equations. Curves *a* are derived from expressions for first-order polymerization and zero-order dissociation; *b*, from zero-order polymerization and first-order dissociation; *c*, from second-order polymerization and first-order dissociation; and *d*, from first-order polymerization and second-order dissociation. Constants for curves *a* and *c* have units of (nanometers)⁻¹ and curves *b* and *d* have units of nanometers.

(Fig. 9 *b*). In this case, the apparent pool under both growth conditions was made equal, implying that D₂O can indeed modify pool size, while at the same time driving the equilibrium to completion. Removal of D₂O from the 0°C growth condition cells by perfusion with normal seawater produced a cell whose maximum birefringence at 20°C was indistinguishable from that of a cell grown at 8°C, confirming this conclusion.

DISCUSSION

It should be obvious from Figs. 4–7 that mitotic cells grown at either 0 or 8°C and observed at various temperatures at active metaphase behave in the same manner as arrested metaphase oocytes (cf. Inoué and Sato, 1967). These two growth

temperature conditions have distinctly different sizes of available pool, but attain maximum polymerization at essentially the same temperature, namely, above 12°C. Interestingly and perhaps significantly, this temperature represents the point of division arrest, at the upper ecological limit for normal and synchronous larval development in *S. drobachiensis* (Stephens, 1972 *a*). The thermodynamic parameters of spindle association for these low temperature cells are compared in Table I with those derived for polychaete oocytes by Inoué and collaborators and for isolated spindles of starfish oocytes by Sato and Bryan (1968). The numerical agreement with *Pectinaria* and *Pisaster* is striking, demonstrating that not only is the basic phenomenon of dynamic equi-

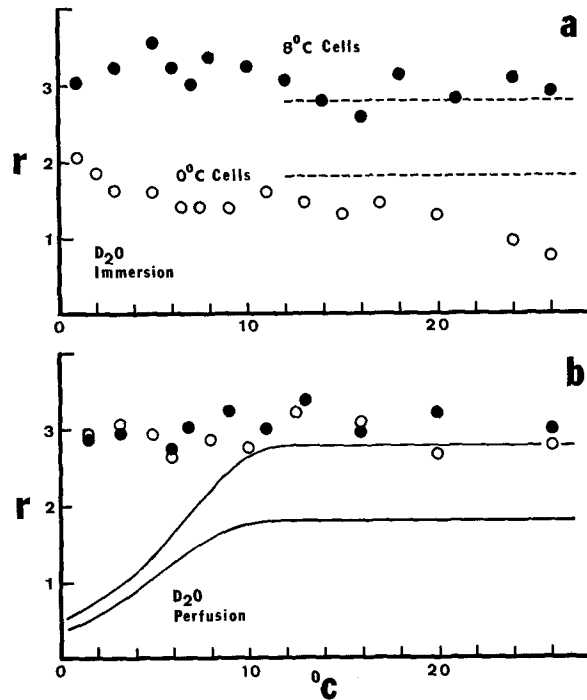

FIGURE 9 Equilibrium retardation of metaphase spindles in the presence of 50% D₂O. (a) Results obtained by direct mixing of cells with D₂O at the growth temperature and equilibrating at the observation temperature. Dotted lines are the A₀ values determined in H₂O, from Figs. 4 and 5. (b) Results obtained by perfusion of cells at observational temperature with 50% D₂O. Solid curves are the equilibrium functions for 8°C cells (upper) and 0°C cells (lower) as calculated from the least-square lines of Figs. 6 and 7. In both a and b, the solid circles are data from 8°C cells and the open circles are from 0°C cells.

TABLE I
Comparison of Thermodynamic Parameters from Arrested and Active Metaphase Equilibria

	ΔH	ΔS	T ($\Delta G = 0$)
	kcal	eu	°C
<i>S. drobachiensis</i> eggs (this report)	+64.5 (0°C)	+233 (0°C)	4 (0°C)
	+54.9 (8°C)	+197 (8°C)	5 (8°C)
<i>Pectinaria gouldii</i> oocytes (Carolan et al., 1965)	+58.4 (H ₂ O)	+204 (H ₂ O)	13 (H ₂ O)
	+44.1 (D ₂ O)	+154 (D ₂ O)	—
<i>Pectinaria gouldii</i> oocytes (Carolan et al., 1966)	+82 (H ₂ O)	+286 (H ₂ O)	—
	+59 (D ₂ O)	+208 (D ₂ O)	—
<i>Chaetopterus pergamentaceus</i> oocytes (Inoué, 1959, 1964)	+28.4 (H ₂ O)	+98 (H ₂ O)	19 (H ₂ O)
<i>Pisaster ochraceus</i> isolated meiotic spindles (Sato and Bryan, 1968)	+58.9 (H ₂ O)	+210 (H ₂ O)	—
	+29.6 (D ₂ O)	+106 (D ₂ O)	—

librium verified at active metaphase, but that the thermodynamic parameters of association are nearly identical with those of the arrested metaphase case. The earlier data for *Chaetopterus* oocytes appears to be somewhat out of line, but its equi-

librium range and total pool are nearly twice that for the other cells and hence the values of ΔH and ΔS would be expected to be roughly halved.

The 0 and the 8°C conditions do differ from

each other with respect to their thermodynamic parameters, but not nearly as much as do the *Pectinaria* H₂O and D₂O figures. The differences are in the same relative direction; those with higher pool size (8°C and D₂O) appear to undergo lower enthalpy and entropy changes. Perhaps the argument that the 0 and 8°C thermodynamic differences are methodological, reflecting differing geometrical distribution of oriented material in cells of larger pool size, is at least partially applicable to the H₂O vs. the D₂O situation. In addition, it may be noteworthy that the earlier H₂O data from *Pectinaria* are almost numerically equal to the later D₂O data (58 vs. 59 kcal and 204 vs. 208 eu in Carolan et al., 1965 vs. 1966), with the overall higher values of the later study being ascribed "presumably to technical improvements." Considering the very real possibility of systematic methodological error, one must exercise caution in interpreting differences between 0 and 8°C growth conditions on one hand and H₂O vs. D₂O treatment on the other. Larger pools appear to produce smaller thermodynamic parameters, but they also produce larger spindles with prominent asters. What does appear to be important is the now characteristic high positive enthalpy and entropy changes associated with metaphase equilibrium, whether arrested or active. Presumably these properties reflect the addition of dimeric tubulin to microtubules.

It is encouraging to see that such a different system, cells in active mitosis, at low temperature, and with different pool sizes, display spindle equilibrium properties which fit the dynamic equilibrium model. Of course this is not proof of an equilibrium mechanism for mitotic movement but it does indicate that arrested and active metaphase are quite comparable with respect to temperature behavior and, therefore, deductions derived from the former are applicable to mitosis in general. Furthermore, the similarity in equilibrium behavior of spindles from prophase through early anaphase, followed by an apparent disappearance of the heat-polymerizable pool would give further credence to Inoué's basic premise that initial establishment of the spindle from an increasingly available pool results in equi-positioning of chromosomes and that, after disjunction, a disassembly of the spindle (by removal or deactivation of that same pool?) could result in chromosome separation and movement (Inoué and Sato, 1967; Stephens, 1972 *b*). It

may be significant that, at temperatures where all available "monomer" has been driven to polymer, the mitotic spindle is no longer functional; perhaps this "forced" polymerization prohibits a requisite disassembly process and hence stops mitotic movement.

The mechanism by which spindle fibers might shorten remains obscure, but as pointed out previously (Stephens, 1972 *b*), the recent observations of two distinct microtubule surface lattices (Grimstone and Klug, 1966; Thomas, 1970; Cohen et al., 1971) now opens the possibility that subunits could be added or removed from along the entire length of a microtubule. In fact, to go from one surface lattice to the other, a dislocation in the subunit array and a local translocation of protofilaments must occur. It remains to be demonstrated whether either subunit lattice has any physiological significance, but both have been observed in the same, reasonably preserved, singlet microtubules (Thomas, 1970), the two forms being separated by a "transition zone." Perhaps these zones move unidirectionally along the tubule in a peristaltic manner (cf. Thornburg, 1967), in transit either expelling or incorporating subunits. Waves of poleward birefringence changes, the "Northern Lights" effect of Inoué (Inoué, 1964; La Fountain, 1969), are in keeping with this speculation. Given such a mechanism for elongation or shortening of spindle fibers, the theory's apparent violation of newtonian mechanics could be answered.

If, on the basis of high positive enthalpy and entropy changes, it can be accepted that spindle protein polymerization is indeed a function of hydrophobic or entropic bonding, mitotic assembly can then be compared with other better-studied systems. Since some of these have been characterized *in vitro*, factors influencing polymerization can be considered in regard to mitotic spindle assembly or disassembly. Obviously, a temperature-dependent polymerization is not directly relevant to mitosis but other more subtle and more physiological changes may be of great importance in specifying equilibrium position.

In TMV A-protein association, very slight differences in ionic strength or pH can easily shift the overall position of the equilibrium curve by 10°C or more (cf. Khalil and Lauffer, 1967) and, if applied to spindle equilibrium, differences in milieu of this sort could explain the near-identical equilibrium parameters in cells with such differ-

ing natural division temperatures as *Strongylocentrotus* and *Pectinaria*. The equilibrium curves are essentially identical, except that they are shifted along the temperature scale relative to one another. Again, considering the in vitro behavior of the TMV A-protein system, but now given constant temperature conditions, a small ionic strength or pH change could move the equilibrium position from a predominantly dissociated to an associated state. Whether changes in ionic strength of 0.02 or pH changes of perhaps 0.1 actually take place in the cell during mitosis, either generally or locally, or whether species differ intracellularly by these amounts or more is, of course, another unanswered question. Another parameter which may influence equilibrium position is that of free calcium ion concentration, recently shown by Weisenberg (1972 *a*) to be critical to the in vitro polymerization of 6S brain tubulin, a process which, like that of the spindle, appears to be endothermic. On the other hand, the differences between various species may simply reflect differences in spindle protein association inherent in evolutionarily determined primary structure.

It may also be useful to compare some similarly behaving thermodynamic parameters derived from in vitro studies, using a few selected and diverse examples. Scott and Berns (1965) investigated the hexamer association in phycocyanin and found a ΔH of +24 kcal and a ΔS of +100 eu, indicating hydrophobic or entropic bonding. Actin polymerization has been implicated as a hydrophobic system, based on two quite different lines of evidence. Asakura et al. (1960) demonstrated that for the normal ATP-dependent G to F transformation to occur a minimum temperature was required, the magnitude of which was proportional to actin concentration; by plotting log of the G-actin concentration against the reciprocal absolute temperature, these workers obtained a ΔH of +12 kcal for this concentration dependence. Since the total reaction is actually exothermically driven by ATP hydrolysis to polymer, no meaningful ΔS could be calculated. Using G-ADP-actin in the absence of ATP, Grant (1965) was able to demonstrate thermally reversible polymerization, again with high positive enthalpy and entropy changes of +33.8 kcal and +146 eu, respectively, measured in the absence of ATP hydrolysis. In the most completely studied system, that of TMV A-protein, Bannerjee and Lauffer (1966) found, by osmotic pressure

measurements at low temperatures, that the initial association had ΔH and ΔS values of +30 kcal and +124 eu, respectively, contrasted with higher temperature polymerization where these values were about +200 kcal and +700 eu (Stevens and Lauffer, 1965), determined under comparable conditions but by the use of light scattering to measure the resulting higher polymers. These two sets of values were interpreted as reflecting differing hydrophobic sites in the polymerizing unit, the relative interactions of which were, themselves, temperature dependent (Lauffer, 1965). It has since been found that TMV association is somewhat more complex than the simple additive polymerization assumed by Lauffer and co-workers; the A-protein associates (probably as a trimer) to form double "washers" which, in turn, associate while undergoing a rearrangement of subunits to form "lock-washers" entrapping an RNA strand as they undergo this rearrangement (Butler and Klug, 1971).

Originally, it was intended that this study include equilibrium curves at active metaphase determined in the presence of D₂O so that the resulting thermodynamic parameters might be compared with those of Carolan et al. (1965, 1966). It is obvious from the perfusion results discussed above that slow application of D₂O at observational temperatures not only drives the equilibrium to complete polymerization, but appears to erase all growth temperature-induced pool size differences (Fig. 9 *b*). Immediate application via dilution at the growth temperature likewise drove the association toward completion, but in this case the maximum retardation was approximately that of the A_0 values derived for H₂O. The equilibrium shift also has its parallel in the in vitro literature, for Khalil and Lauffer (1967) found that pure D₂O shifted the equilibrium curve for the TMV A-protein association toward a substantially lower temperature, more than sufficient to explain the 8–10°C shift that the above observation would imply. In addition Paglini and Lauffer (1968) found that D₂O markedly influenced the low temperature TMV polymerization so that it resembled the higher temperature association. Khalil and Lauffer (1967) found that the thermodynamic parameters for TMV A-protein association in D₂O were in general somewhat higher than those for association in H₂O. This is in contrast to the spindle equilibrium studies of Carolan et al. (1965, 1966), where

typically lower D₂O values were obtained even though the polymerization was driven further toward completion.

How the slow application of D₂O equalizes the 0 and 8°C apparent monomer pools is a further mystery. Perhaps the mobilization of tubulin takes place from a particulate source (cf. Weisenberg, 1972 *b*) dispersed throughout the cell; rapid immersion in D₂O might "lock" everything in polymeric form wherever it is in the cell while slow perfusion might allow mobilization of this material and its subsequent polymerization into the spindle proper. The effects of D₂O on both in vitro and in vivo systems are apparently complex and difficult to explain by simple assumptions about changes in pool size or in ordering of water structure, although both systems appear to behave in a related manner. Perhaps the many similarities between in vivo spindle association and other protein systems thought to interact by means of hydrophobic or entropic bonding may soon lead to a better understanding of the initiation of microtubule polymerization, positioning and assembly of spindle fibers, the role of spindle fibers in chromosomal movement, and the disassembly of spindle fibers at the completion of mitosis.

The author wishes to thank Doctors S. Inoué, J. W. Fuseler, and E. D. Salmon for many fruitful discussions concerning spindle equilibrium and mechanics.

This work was carried out under United States Public Health Service grant GM 15,500 and Research Career Development Award GM 70,164 from the National Institutes of Health, Division of General Medical Sciences.

Received for publication 15 August 1972, and in revised form 27 November 1972.

REFERENCES

- ASAKURA, S., M. KASAI, and F. OOSAWA. 1960. The effect of temperature on the equilibrium state of actin solutions. *J. Polym. Sci.* 44:35.
- BAILEY, N. T. J. 1966. *Statistical Methods in Biology*. English University Press Ltd., London.
- BANERJEE, K., and M. A. LAUFFER. 1966. Polymerization-depolymerization of tobacco mosaic virus protein. VI. Osmotic pressure studies of early stages of polymerization. *Biochemistry*. 5:1957.
- BUTLER, P. J. G., and A. KLUG. 1971. Assembly of the particle of tobacco mosaic virus from RNA and disks of protein. *Nat. New Biology*. 229:47.
- CAROLAN, R. M., H. SATO, and S. INOUÉ. 1965. A thermodynamic analysis of the effect of D₂O and H₂O on the mitotic spindle. *Biol. Bull. (Woods Hole)*. 129:402.
- CAROLAN, R. M., H. SATO, and S. INOUÉ. 1966. Further observations on the thermodynamics of the living spindle. *Biol. Bull. (Woods Hole)*. 131:385.
- COHEN, C., S. C. HARRISON, and R. E. STEPHENS. 1971. X-ray diffraction from microtubules. *J. Mol. Biol.* 59:375.
- GRANT, R. J. 1965. Reversibility of G-actin-ADP polymerization: physical and chemical characterization. Ph.D. Thesis. Columbia University, New York.
- GRIMSTONE, A. V., and A. KLUG. 1966. Observations on the substructure of flagellar fibers. *J. Cell Sci.* 1:351.
- INOUE, S. 1952 *a*. Effects of temperature on the birefringence of the mitotic spindle. *Biol. Bull. (Woods Hole)*. 103:316.
- INOUE, S. 1952 *b*. The effect of colchicine on the microscopic and submicroscopic structure of the mitotic spindle. *Exp. Cell Res.* 2(Suppl.):305.
- INOUE, S. 1953. Polarization optical studies of the mitotic spindle fibers in living cells. *Chromosoma*. 5:487.
- INOUE, S. 1959. Motility of cilia and the mechanism of mitosis. *Rev. Mod. Phys.* 31:402.
- INOUE, S. 1964. Organization and function of the mitotic spindle. In *Primitive Motile Systems in Cell Biology*. R. D. Allen and N. Kamiya, editors. Academic Press Inc., New York. 549.
- INOUE, S., and H. SATO. 1967. Cell motility by labile association of molecules. The nature of mitotic spindle fibers and their role in chromosome movement. *J. Gen. Physiol.* 50:259.
- INOUE, S., G. W. ELLIS, E. D. SALMON, and J. W. FUSELER. 1970. Rapid measurement of spindle birefringence during controlled temperature shifts. *J. Cell Biol.* 47(2, Pt. 2):95 a. (Abstr.)
- KHALIL, M. T. M., and M. A. LAUFFER. 1967. Polymerization-depolymerization of tobacco mosaic virus protein. X. Effects of D₂O. *Biochemistry*. 6:2474.
- LA FOUNTAIN, J. 1969. Fluctuations in spindle birefringence: the "Northern Lights phenomenon." *J. Cell Biol.* 43(2, Pt. 2):167 a. (Abstr.)
- LAUFFER, M. A. 1965. Polymerization-depolymerization of tobacco mosaic virus protein. VII. A model. *Biochemistry*. 5:2440.
- PAGLINI, S., and M. A. LAUFFER. 1968. Polymerization-depolymerization of tobacco mosaic virus protein. XI. Osmotic pressure studies in water and in deuterium. *Biochemistry*. 7:1827.
- SATO, H., and J. BRYAN. 1968. Kinetic analysis of association-dissociation reaction in the mitotic spindle. *J. Cell Biol.* 39(2, Pt. 2):118 a. (Abstr.)
- SATO, H., S. INOUÉ, and G. W. ELLIS. 1971. The microtubular origin of spindle birefringence: ex-

- perimental verification of Wiener's equations. Abstracts of Papers, Eleventh Annual Meeting of The American Society for Cell Biology, New Orleans.
- SCOTT, E., and D. S. BERNIS. 1965. Protein-protein interaction. The phycocyanin system. *Biochemistry*. 4:2597.
- SHALABY, R. A. F., and M. A. LAUFFER. 1967. Polymerization-depolymerization of tobacco mosaic virus protein. IX. Effect of various chemicals. *Biochemistry*. 6:2465.
- SMITH, C. E., and M. A. LAUFFER. 1967. Polymerization-depolymerization of tobacco mosaic virus protein. VIII. Light scattering studies. *Biochemistry*. 6:2457.
- STEPHENS, R. E. 1971. Correlation of mitotic spindle birefringence with tubulin content: evidence for natural variation in pool size. Abstracts of Papers, Eleventh Annual Meeting of the American Society for Cell Biology, New Orleans.
- STEPHENS, R. E. 1972 *a*. Studies on the development of the sea urchin *Strongylocentrotus droebachiensis*. I. Ecology and normal development. *Biol. Bull. (Woods Hole)*. 142:132.
- STEPHENS, R. E. 1972 *b*. Studies on the development of the sea urchin *Strongylocentrotus droebachiensis*. II. Regulation of mitotic spindle equilibrium by environmental temperature. *Biol. Bull. (Woods Hole)*. 142:145.
- STEVENS, C. J., and M. A. LAUFFER. 1965. Polymerization-depolymerization of tobacco mosaic virus protein. IV. The role of water. *Biochemistry*. 4:31.
- THOMAS, M. B. 1970. Transitions between helical and protofibrillar configurations in doublet and singlet microtubules in spermatozoa of *Stylochus zebra* (Turbellaria, Polycladida). *Biol. Bull. (Woods Hole)*. 138:219.
- THORNBURG, W. 1967. Mechanisms of biological motility. In *Theoretical and Experimental Biophysics*. A. Cole, editor. Marcel Dekker, Inc., New York. 1:77.
- WEISENBERG, R. C. 1972 *a*. Microtubule formation *in vitro* in solutions containing low calcium concentrations. *Science (Wash. D. C.)*. 177:1104.
- WEISENBERG, R. C. 1972 *b*. Changes in the organization of tubulin during meiosis in the egg of the surf clam *Spisula solidissima*. *J. Cell Biol.* 54:266.