



Research article

Place attachment and agricultural land conversion for sustainable agriculture in Indonesia

Gunawan Prayitno^{a,*}, Dian Dinanti^a, Izzatul Ihsansi Hidayana^a, Achmad Tjachja Nugraha^b^a Regional and Urban Planning Department, Faculty of Engineering, Indonesia^b Syarif Hidayatullah State Islamic University, Jakarta, Indonesia

ARTICLE INFO

Keywords:

Place attachment
Agricultural land conversion
Sustainable agriculture
Structural Equation Model

ABSTRACT

The relationship between place attachments and agricultural land conversion for developing countries had not been studied in many studies. This study aimed to provide empirical evidence of the psychological relationship between place attachment and agricultural land conversion, in contributing to sustainable agriculture in rural areas. The method used was the calculation of the place attachment index, while examining the relationship between latent and dependent variables implemented in Structural Equation Model (SEM), applied in AMOS Software. The result of the Structural Equation Modeling (SEM) calculation demonstrated the relationship between place attachment and agricultural land conversion. The attitude towards land development also had a weight of 0.657, which is substantially optimistic. Also, the weight value indicated that the place attachment relationship positively impacted the desire to maintain land, as maintenance decision was higher when the place attachment was high. That was accompanied by a 31.6% value of R², meaning that the place attachment influenced 31.6% of the variance in the decision to preserve land.

1. Introduction

Land for farmers is not only a place for growing crops, jobs, and leisure activities, it is also a site full of history (touching symbols) and repository feelings (Nassauer, 2011; Quinn et al., 2014; Tveit et al., 2006). The shift in land used results in the sense of loss (Maladi, 2013), pleasure, sorrow, and nostalgia (Canter, 1977), which reduces farmers' agricultural interests (Wrachien, 2003). Changes in land use caused by population growth (Basuki et al., 2010; Prayitno, Sari, et al., 2019) have led to rural becoming urban areas, with changes in lifestyles resulting in complex processes (Antrop, 2000; Fitriantatsany, 2017; Prayitno, Subagiyo, et al., 2019).

The driving force behind the land conversion is generally economic (Kuehne, 2013; Zhang et al., 2019), although social factors (Chen et al., 2019; Xu et al., 2019). One of the social conditions is described in the form of place attachment. The attachment of farmers/landowners to land has been widely discussed and investigated in the rural study literature. The research of (Lin and Lockwood, 2014), showed that the more farmers are linked to their land, the greater the tendency to defend the place. Also, such a relationship with nature has also been described in other works (Davis et al., 2009; Lokocz et al., 2011; Manstead, 2011). Place

attachment appears to provide insight into how people respond to change, which is conceptualized as an emotional bond between individuals and their environment (Halpenny, 2010; Jorgensen and Stedman, 2001; Prayitno, Dinanti, et al., 2019; Raymond et al., 2010; R. C. Stedman, 2003). Although different disciplines studied place and community attachments (Trentelman, 2009), both are still observed to appear similar. Also, other works had shown that farmers need a deep commitment to the land in their lives (Flemsæter, 2009; Hildenbrand and Hennon, 2005; Kuehne, 2013). Generally, farmers maintain their land deeply and securely, despite the awareness that they are unable to carry out the maintenance indefinitely (Cheshire et al., 2013; Flemsæter, 2009; Kuehne, 2013).

In order to secure the agriculture land conversion, the Indonesian Government released Law No. 41 in 2009, which applied Articles 20, 21, 27(2), 28A, 28C, and 33 of the Republic of Indonesia's 1945 Constitution. This was then enforced by Regulation Government No. 1 of 2011, on the Classification and Transition of Sustainable Food Agricultural Land (SFAL/LP2B- *Lahan Pertanian Pangan Berkelanjutan*). In the course of this process, two things are achieved in this law. Firstly, the conversion of agricultural land was prohibited, by developing "Sustainable Food Agricultural Land" (LP2B/SFAL). LP2B is a statute covered paddy field, which

* Corresponding author.

E-mail address: gunawan_p@ub.ac.id (G. Prayitno).

is not to be used for other purposes except agriculture, for 20 years. The LP2Bs are determined by the regional government (district level), through the issuance of a district regulation (PERDA) on the areas to be transformed. Secondly, provision of incentives for farmers, in order to continue their farming activities. Specifically, incentives have also been developed, in order to reduce land taxes, improve infrastructures, finance research, develop high-yield varieties, encourage access to agricultural information and technology, provide farm inputs, secure site tenure, and increase farmers' achievements (Perindungan Lahan Pertanian Berkelanjutan, 2009). The main goal is to increase agricultural products' economic value, which in turn helps to decrease farmers' interest in changing land functions, or selling their sites for other purposes (Rondhi et al., 2018).

Farmers in Indonesia are also unable to protect their lands, due to social and economic pressures, making farmland conversion unavoidable (Ashari, 2016; Subagiyo et al., 2020). Provided the problem of changing farmland's role for food, agricultural (paddy) to non-agricultural lands tends to occur annually. The results of the data from the Central Statistical Board (2019) and Area Sampling System (ASF) satellite imagery, showed a decrease from 7.75 to 7.4 million hectares of crude rice field within 2013–2019, respectively, in Indonesia. This indicates a drastic shortfall, as a result of the conversion of agricultural land. The Central Statistical Board (BPS) inevitably recommends that the conversion of agricultural land should be stopped immediately, by a strict policy. Besides that, incentives should be offered to farmers, in a bid to help them preserve their farmland (Prawira and Ariastita, 2014). A study (Bryan, 2013) further discovered that incentives promote many improvements in land use, as they also lead to several benefits that impact ecosystem services. Moreover (Pannell, 2006), described that incentives enabled the trial of new techniques by farmers, while also compensating landowners for land-use changes.

This raises consciousness of how the position of place attachment affects farmers' attitudes and actions, as regards people-location and land-change decisions. As regards landowners, the relationship to the cultivation of the land continues when they retain their site. Most times, when landowners are unable to keep farming; sustainable agriculture becomes hard to maintain, as agricultural production declines, with the lack of farmers' land preservation interests also jeopardizing national food security. This study aims to establish the relationship between place attachments of landowner to the decision to change the land use. Further research was also carried out, in order to know whether the government's incentives often affect land sale decisions or not. Also, a study of psychological experiences in rural areas offers another viewpoint on how environmental condition affects farmer psychology, in relation to the land they own. The research question includes,

- (1) Does the place attachment index influence the decision to change the land use?
- (2) What is the relationship between place attachments and attitudes towards the change of land, which in turn affects the site changing decisions?

2. Theoretical background

2.1. Place attachment

The place attachment had been defined differently by researchers, and a multifaceted structure is commonly understood (Halpenny, 2010; Lokocz et al., 2011; Raymond et al., 2010; Scannell and Gifford, 2010). This includes the identity of place (Prayag and Ryan, 2011; R. Stedman et al., 2004), the impacts of the location (Hinds, J., & Sparks, 2008), the social connections in the region (Ramkissoon et al., 2012, 2013), and the reliance or dependence on the site (G. Brown et al., 2015; Prayag and Ryan, 2011; Raymond et al., 2017). The literature has increased scientifically and methodologically, while also in different fields, including environmental psychology and education, natural resources

management, and tourism (Ganji et al., 2020; Halpenny, 2010; Ramkissoon et al., 2012).

The definition and the characteristics of position attachment are based on the literature related to environmental perception and psychology. Environmental satisfaction and affection for the place attachment (Ernawati, 2014) is also responsible for a deep link to the location, as it decreases the ability to change land (G. Brown et al., 2015; Raymond et al., 2017; Xu et al., 2019). A personal context approach was employed to calculate place attachments in this study (Lokocz et al., 2011). These included, identity (Prayag and Ryan, 2011), place dependence (G. Brown et al., 2015; Prayitno et al., 2021), community [friend and family bonds] (Raymond et al., 2010) and nature environmental (G. Brown et al., 2015) contexts.

2.2. Agricultural land conversion

Social, economic, and government policies to regulate the sector or national growth leads to land use change (Dewi and Sarjana, 2015; Putra, 2006). The forces driving change in land use are divided into external and internal factors (Prayitno et al., 2018; PUSPIJAK and FFCPPF, 2012). The internal and external factors are very much related to decreasing soil fertility, and economic pressures, respectively. Based on the research of (Agus and Irawan, 2006), there were 187,720 ha of agricultural land use change each year. Most of the lands converted were used in construction and housing production sites. Moreover, housing development accounted for 48.96% of the land converted, accompanied by industrial and office development at 36.50% and 14.55%, respectively (Irawan, 2008).

As regards other (non-agricultural) land use, agricultural farmland has a low value, resulting in continued conversions into non-agriculture (Kusumastuti et al., 2018; Rondhi et al., 2018). Additionally, to having economic value as a buffer for food security, agricultural land (rice fields) also has an ecological role, such as the control of water management, absorption of carbon in the air, and more (Yoon, 2009). The advantages of agricultural land should be preserved and not ignored, due to the fact that the conversion of farmland often disrupts the socio-economic life of farmers (Prayitno et al., 2020), as perceived socio-economic shifts appear to be detrimental to the farming community (Curran-Cournane et al., 2016).

2.3. Place attachment, agricultural land conservation, and sustainable agriculture

Rural areas are observed to have also undergone substantial economic, social, and demographic changes (Xu et al., 2019). There was a change from a farm area to a location with multiple functions, making it an ideal rural environment. In view of these dramatic changes, the village planner needs to understand how local residents are attached to different habitats, and also the ways by which the sense of place varies with the population's time of stay (Prayitno and Subagiyo, 2018; Wiles et al., 2017). Therefore, the relationship between the village's physical state, with the rural and population characters, are likely emotional and nuanced.

Traditional rural areas are usually subject to incremental change, as they tend to maintain their stability, and migrate more quickly from suburban to urban locations. However, recent migrations into peri-urban areas have produced unprecedented growth in rural areas, threatening the local characters and attachments to surrounding lands (B. Brown et al., 2004). Developmental changes in the land also have major effects on the place attachment (Jorgensen and Stedman, 2001; Stedman Richard C., 2003). When people are attached to a place, they appear to resist changes to rural characteristics in the suburbs (Collins-Kreiner, 2020; Iaquina and Drescher, 2000; Ramkissoon et al., 2013). Also, people with high level of commitment are more tolerant of land management policies, in order to conserve rural sites (Raymond et al., 2017; Walker and Ryan, 2008), and protect individuals with strong connection to their place of residence. Therefore, those that feel committed to a place

to live should be mindful of preserving their environment (Budruk et al., 2009).

Based on previous studies' hypothesis, not only the people's attitude towards land conversion was identified, their decision to change the land was also observed (Lokocz et al., 2011). This decision should be carried out in the form of a policy approval, in order to convert the sites into protected land (Lokocz et al., 2011; Raymond et al., 2017). Therefore, the relationship between the place attachment and the population's decision to preserve agricultural land or not, were identified. This is connected to the sustainability of agriculture in the village, as farmers' more significant decision to change the land leads to a decrease in farmland area, which in turn reduces agricultural production eventually (Rondhi et al., 2018).

3. Methods

3.1. The data

This study aimed to show the effect of place attachments on carrying out an agricultural land conversion. Place attachment is the emotional bond of respondents to the village/*kelurahan* where they reside. The place attachment for landowners of paddy field in Pandaan District was measured using 5 (five) dimensions, namely PI, PD, FB, FRB, and NB [Place Identity, Place Dependence, Family Bonding, Friend Bonding, and Nature Bonding] (Halpenny, 2010; Lokocz et al., 2011; Raymond et al., 2017), as the dimension had its respective assessment indicators, which were included in the questionnaire. These questionnaires are based on literature analysis of the place attachments, which are to be answered by the owners of agricultural land properties.

In this study, the population consisted of farmers living and owning food agricultural land in Pandaan District. The population of food farming landowners in each village within Pandaan District, were derived from the 2019 Definitive Group Needs Plan (RDKK), which included the names of farmer groups, numbers of respondents, and the land area. Also, Pandaan district had 5,951 farmers that were sustainable food agriculture (LP2B) landowners, as purposive sampling was used in the collection of samples. The Isaac and Michael formula were further used to calculate the number of samples, with a 5% error rate. In order to avoid bias in the study, the number of samples in Pandaan District was increased to 500 farmers from the initial 381.

Furthermore, data from 500 landowners were collected in this research. Farmers with paddy field land were chosen from each village,

within the Pandaan district, as the survey was performed from September 2019 to February 2020. The survey comprises of two sections,

- (1) Emphasis on questions of connection between place attachment and land use change,
- (2) Emphasis on farmers' characteristics.

Data were further collected, and statistically analysed in this research. Within the many measures surveyed in classifying the respondents, only the most important ones (education, duration of stay, and income) were used, because their relationship was most robust with the individual dimensions of the 1–5 Likert scale expertise. After testing the assumptions' validity, the total samples (500 respondents) were analyzed in Structural Equation Model (SEM), with AMOS Software.

3.2. Study area

Pasuruan Regency was selected, due to having a sub-district adjacent to Surabaya, which is traversed by the Trans Java toll road. Due to this result, the possibility of converting agricultural sites to non-agricultural land was quite high, as Pandaan District was one of the Pasuruan Regency's sub-districts with Sustainable Land for Food Agriculture. According to Pasuruan data, there was a change in agricultural land's function to toll roads, totalling 482,249 m² or 45.92% of agricultural land in 2020 (BPS Pasuruan, 2020). Furthermore, Pandaan District is a sub-district traversed by a primary arterial road, which connects major cities in East Java (Surabaya) and Malang City, resulting in rapid economic and business development high demand, for non-agricultural land. However, the developments in the Pandaan district had led to land use change, which is related to place attachments owned by residents of the location.

3.3. Research variable

Variables are elements that have been researched and gathered from various sources. The variables used in this study were those that are relevant to the research problem, as indicated in Table 1.

Table 1. The variables, indicators, informations and sources.

Variable	Indicators	Information	Sources
Place identity (PI)	This village means a lot to us (PI1)	This village/ <i>kelurahan</i> has many memories of family and friends.	(Raymond et al., 2010)
	I am attached to this village/ <i>Kelurahan</i> (PI2)	In this village, we have various assets (houses, land, other companies).	
	In this village/ <i>Kelurahan</i> , I have many memories (PI3)	Since this town/ <i>kelurahan</i> is my place of birth	
	This village/ <i>Kelurahan</i> is very special to me (PI4)	Since I work, have a family, and do everyday activities in this village.	
	I believe that this village/ <i>Kelurahan</i> is a part of me (PI5)	He/she had been living for a long time in this village/ <i>Kelurahan</i>	
	I quite strongly identify this village/ <i>kelurahan</i> (PI6).	Since he has been living in this village/ <i>kelurahan</i> for a long time	
Place dependence (PD)	I am happier in this village/ <i>kelurahan</i> than elsewhere (PD1)	Since I lived in a different village/ <i>kelurahan</i> , but feel more comfortable living in this village/ <i>kelurahan</i>	(Raymond et al., 2010)
	There is no other place like this village/ <i>Kelurahan</i> (PD2).	Since there is agricultural land in this village/ <i>kelurahan</i> to be taken care of	
		Since he has been employed as a farmer in this village for a long time.	

(continued on next page)

Table 1 (continued)

Variable	Indicators	Information	Sources
	I do not want to do something that's generally done in this village/kelurahan elsewhere (PD3)		
	Activities in this village/kelurahan are more important than doing it elsewhere (PD4)	Since I work in this village/kelurahan	
	This village/kelurahan is the perfect village/kelurahan to do my daily job (PD5).	Since I am happy with what I have in this village/ Kelurahan and public facilities.	
Family bonding (FB)	I live in this village, because my family is here, too (FB1).	Both of the extended families live in this village/ kelurahan and the houses are close to each other.	(Raymond et al., 2010)
	My friendship with my family in this village is very special to me (FB2).	There have been many family relics, memories, and rituals left in this village/kelurahan.	
Friend bonding (FRB)	The friendship that grows together because of daily activities in this village/kelurahan is essential to me (FRB1).	Since he has been friends with villagers/sub-districts since childhood.	(Raymond et al., 2010)
	Friendships that developed due to work (agriculture) related activities were significant to me (FRB2).	They need each other according to their respective positions in the farmers' community and can support each other.	
Nature bonding (NB)	When I spend time in the natural surroundings of this village/kelurahan, my feelings are at one with the natural surroundings of this village/kelurahan (NB1).	Since I work on agricultural land, the natural environment in this village/kelurahan is very much attached to me.	(Raymond et al., 2010)
	I feel less close to the animals and plants missing in this village/kelurahan (NB2).	The transfer of agricultural land has had an enormous effect on my life	
	I can understand myself spending time in the natural surroundings of this village/ kelurahan.	Since I have been farming in this village/kelurahan for a long time, there are memories of agricultural land.	
	I am very attached to the natural environment of this village/kelurahan (NB3)	The natural environment in my village/kelurahan still survives when many other villages/kelurahan are being built in Pandaan District.	
	I relax when spending time in the natural environment of this village/kelurahan (NB4)	Away from the crowds and pollution, thus giving peace.	
Decision to Change the Land (DCL)	If there are incentives, I will protect the land (DCL1). If I am not given incentives, I will not protect my land (DCL2). I hold the land without benefits (DCL3). I am not going to protect the land, whether there are incentives or not (DCL4). I kept the land when the investors purchased it, even though there were no reward (DCL5). I will always sell the land when it is purchased by buyers, even though there are benefits (DCL6)		(Lokocz et al., 2011)

3.4. Analysis data methods

3.4.1. Place attachment index (PAI) analysis

In this analysis, place attachment was the emotional link between the respondents and the village/kelurahan they reside. The place attachment of landowner's paddy field in Pandaan district was measured using five dimensions, PI, PD FB, FRB, and NB Place Identity, Place Dependence, Family Bonding, Friend Bonding, and Nature Bonding. Each dimension had its indicators, which were placed in the questionnaire, to be answered by the food-farming property owner. The statement submitted was in the form of a 1 to 5 Likert scale, with the information, (1) significantly disagree, (2) disagree, (3) neutral, (4) agree, and (5) strongly agree.

Index analysis is used in assessing the pattern of respondents' responses to each variable. The index number specified the degree to which the interviewee recognizes the variables in the sample. The calculated variable by index analysis in this study was the attachment of the site,

with the scoring system using a 1–5 Likert scale, i.e., minimum and maximum of 1 & 5, for "Strongly Disagree and Agree", respectively. The index calculation for the answers of the respondents was performed using the following formula (Eq. (1)),

$$\text{Values Index} = ((\%F1 \times 1) + (\%F2 \times 2) + (\%F3 \times 3) + (\%F4 \times 4) + (\%F5 \times 5)) / 5 \tag{1}$$

Notes:

- F1 = The frequency of respondents who answered 1 of a question.
- F2 = The frequency of respondents who answered 2 of a question.
- F3 = The frequency of respondents who answered 3 of a question.
- F4 = The frequency of respondents who answered 4 of a question.
- F5 = The frequency of respondents who answered 5 of a question.

Also, each indicator in filling the classifications used the three-box method (Sugiyono, 2016). The data results were divided into three groups, in order to decide the position of the landowner in the Pandaan district. Before the classification, all score measurements' results are

Table 2. Classification of score levels.

Indexes	Interpretation
20,00–46,67	Low
46,67–73,33	Moderate
73,33–100	High

Sources: (Sugiyono, 2016).

converted into units of 100, in order to simplify the analysis (Table 2). Based on this condition, the score range began with values of 20–100. When the total percentage of respondents' responses (100%) was 1, the score derived from the premises was 20, due to being contained in the formulation. Also, the score becomes 100, when all the respondents' answers (100%) are 5.

3.4.2. Confirmatory factor analysis (CFA)

Confirmatory factor analysis (CFA) is a technique used to validate a measurement model. This analysis was used to determine the variables that influenced the place attachment and the attitude factors, which leads to attempting to defend the land. The CFA was also useful in reducing the indicators that do not represent variables, while further determining the magnitude of a loading factor effect. Also, AMOS 22 Software was used, to perform model testing in CFA.

3.4.3. Structural Equation Modelling (SEM)

SEM is a method combining the regression equation system with single and several linear statistical (regression) analyses (Nunkoo and Ramkissoon, 2012). The Structural Equation Modelling is a second-order technique, and a change in the methodology of factor analysis, where the limitations of certain determinants (common factors) are evaluated on their basis to establish secondary orders.

According to the theoretical design, a fit index reference was required, in order to determine whether the model generated was based on observational data or not. As regards the SEM design analysis, the

model fit index values included Chi-Square, BIC, CAIC, GFI, RMSEA, PGFI, and PRATIO (Schumacker and Lomax, 2012). However, it is also possible to use other indices, such as the adequacy of the sample numbers or the importance value. The researcher compiled a study model hypothesis before carrying out the SEM analysis, which was further used as a guide in design measurements.

4. Results and discussion

4.1. Place attachment in Pandaan District

4.1.1. Place attachment relationship with income

The Pandaan District's income levels ranged from less than IDR 1,000,000 to more than IDR 7,000,000 monthly. With the 2020 regional minimum wage (RMW) of IDR 4,190,133 for Pasuruan Regency, each respondent's income level was categorized in low, medium, middle, and high classes. Each classification had a different degree of attachment to the place, and a distinguished understanding of the decision to preserve the land. The relationship between the role attachment level and the income of the respondent is shown in Table 3.

Based on Table 3, it was observed that the number of respondents categorized as low and medium-income classes, were mainly at a reduced level of place attachment, with those at the middle and high classifications possessing a great degree. It was also inferred that the higher the respondent's income, the greater the degree of their position of attachment. Respondents with high income from agricultural farmland (above RMW in Pasuruan Regency 2020), tend to be reluctant to change their land's function. However, those with income below RMW tend to be willing to change the function or sell the land, when the price offered is sufficient.

4.1.2. Place attachment value index in Pandaan District

The Place Attachment Index was determined, in order to assess the total score of the five dimensions in each village/kelurahan, i.e., PI, PD, FB, FRB, and NB. The results of each village's total score were obtained by measuring the average of each place attachment dimension. The Place

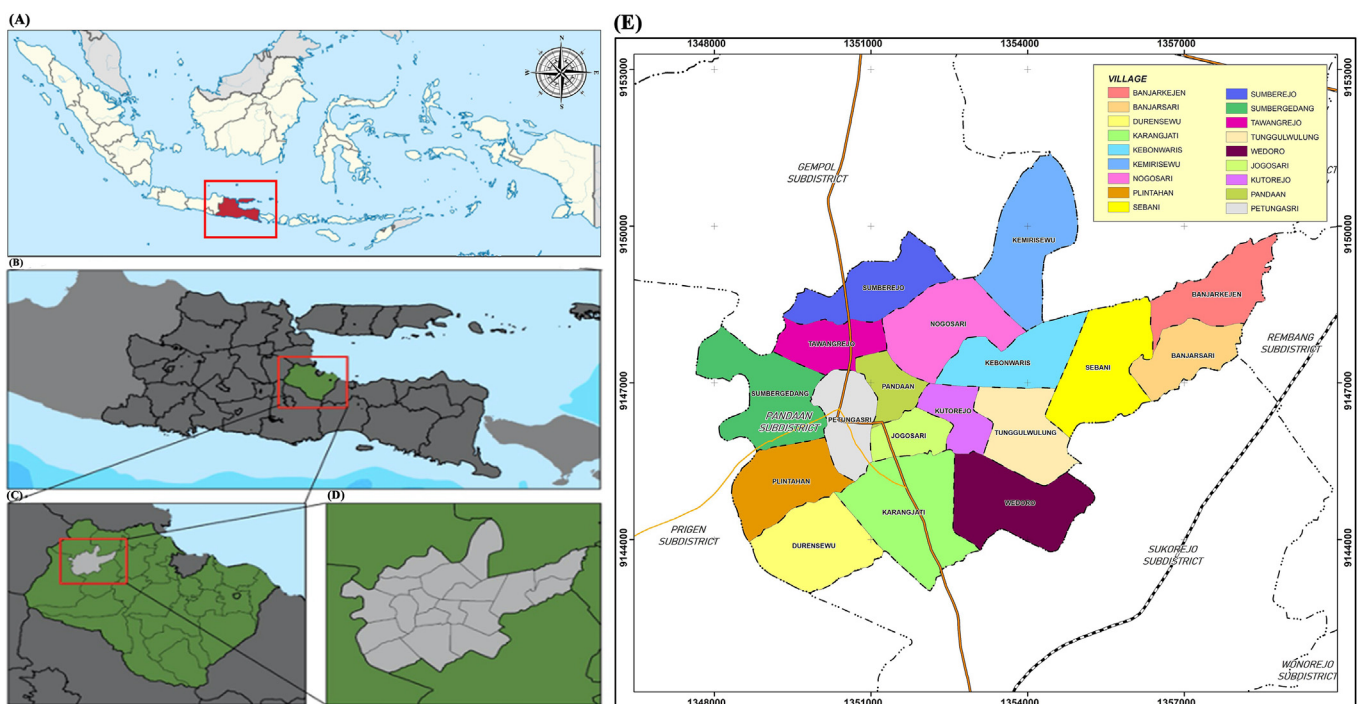

Figure 1. Map of Study Area A. East Jawa in Indonesia. B. Pasuruan Regency to East Jawa. C. Map of Pasuruan Regency, the highlighted area shows Pandaan District. D and E. Pandaan District.

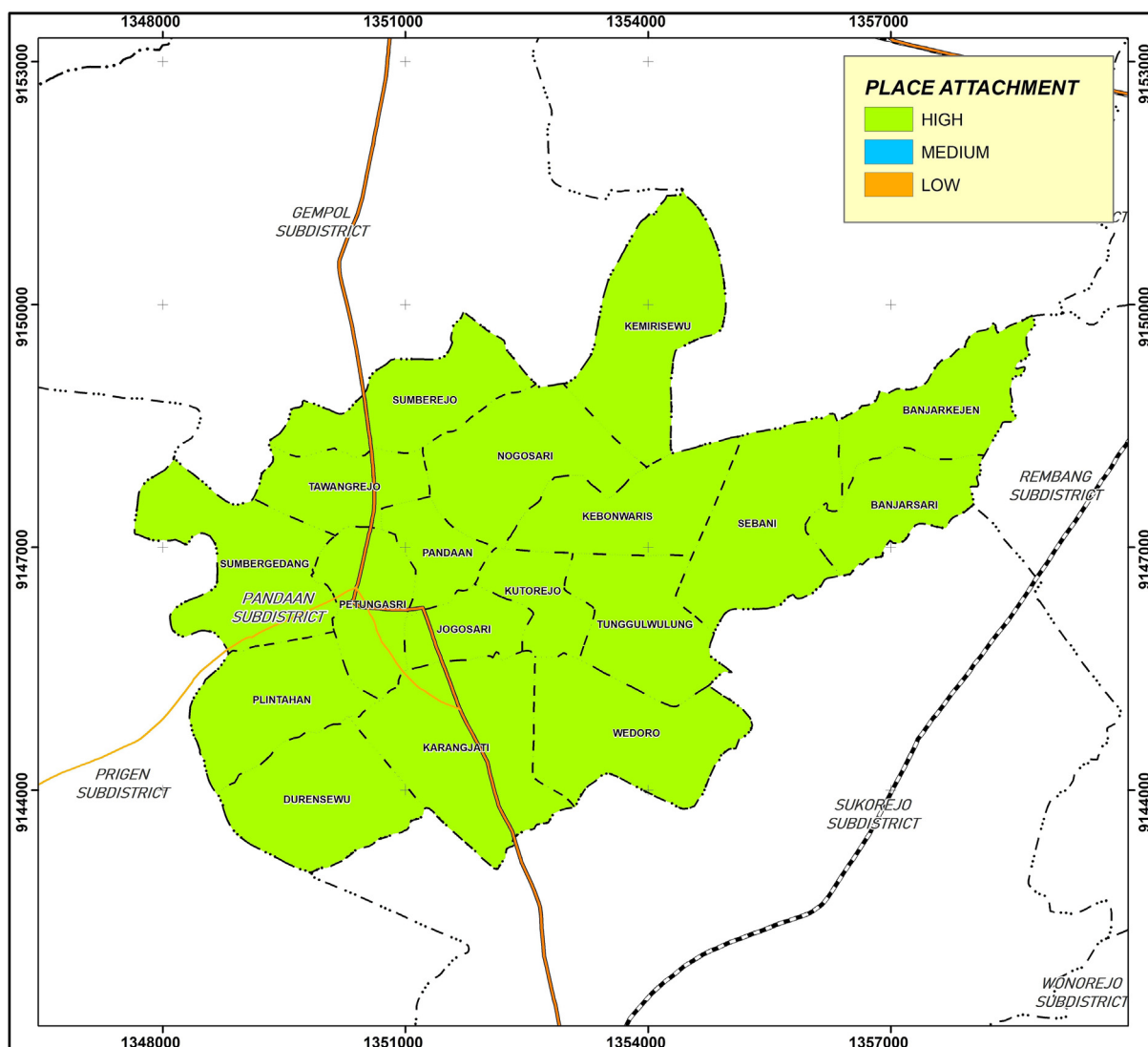

Figure 2. The score of Place Attachment in Pandaan District.

Attachment Dimension Score's mean value defined the overall condition of the position in the Pandaan District. The calculation of the Place Attachment Value Index showed that the dimension is likely to have the great and less effects on the Place Attachment Level of the Respondent, in the Pandaan District. Therefore, the estimation of the total location

attachment score for each village/kelurahan indicated high results (Figure 2) (see Figure 1).

4.1.3. Attitudes of respondents towards land development

The respondent's attitude towards land development was indicated by the intention to change the site variable. This variable correlated with the

Table 3. The relationship between income classification and the place attachment level of respondents.

Income Classification	Income (IDR/month)	Place Attachment Level	The Numbers Respondents
Low	<1.000.000–2.000.000	Low	30
		Moderate	2
		High	2
Medium	2.000.000–4.000.000	Low	39
		Moderate	5
		High	1
Middle	4.000.000–6.000.000	Low	3
		Moderate	22
		High	189
High	>6.000.000	Low	7
		Moderate	24
		High	183

Table 4. Score level classification.

Score Scale Range	Information	Attitude
20-46,67	No effect	Agricultural Land Conversion
46,7-73,33	Neutral	Neutral
73,4-100	Take effect	Maintain agricultural land

Pandaan District Place Attachment value, as a clarification of the respondent's attitude towards land used change was observed in discussing the decision to protect the site.

Indicators DCL1, 3, and 5 suggested that the respondent protected the land, while factors 2, 4, and 6 showed that the farmer is likely to sell/convert the site. Respondents were provided with different answers to each argument in the questionnaire, with their responses determining whether they were likely to protect or change agricultural lands.

Before the classification was carried out, the results of all the score measurements were translated into units of 100, in order to make the analysis simpler. Due to this condition, the score range began from 20 to 100. Based on the assumptions, when the total number of respondents' answers (100%) has a value of 1, the score outrightly becomes 20, when used in the formula. Also, the score of 100 was based on the assumption that all respondents provided complete answers (100% have a value of 5). The following are the results of the respondents' comments on the desire to change property, as the description of the score level are shown in Table 4.

The score range of 20–46.67 indicated that the presence of incentives does not influence respondents in the conservation of the agricultural land, as they opted to sell or change the site. Moreover, the score range of 46.7–73.33 indicated that the respondents were neutral, showing that there were variables making the farmers prefer to protect or change agricultural land. The range of 73.4–100 also showed that respondents prefer to protect agricultural land.

Based on Table 5, it was observed that the DCL1 (Decision to Change Land) predictor had the highest score of 79.48. Incentives provided to agricultural landowners in the Pandaan District affected them, as they opted to protect their land. Most of the respondents in the Pandaan

Table 5. Average value of indicators of respondents' attitudes towards land development.

Indicators of Respondents' Attitudes towards Land Development	Score Values
When there are incentives, I will protect the land (DCL1).	79.48
When I am not given incentives, I will not protect my land (DCL2)	63.16
I hold the land without benefits (DCL3)	69.4
I am not going to protect the land, whether there are incentives or not (DCL4)	51.44
I will keep the land when the investors purchased it, even though there were no reward (DCL5)	60.4
I will always sell the land when it is purchased by buyers, even though there are benefits (DCL6)	60.68

district had opted to protect agricultural land, based on incentives being provided to them. This was due to the fact that the Pandaan district respondents worked as farmers, and possessed viable agricultural land that needs to be cultivated. Revenues from this agricultural land increase the income of the landowner. Most of the respondents received incentives in the form of rice and maize seeds, fertilizer subsidies, and tractors. Therefore, respondents in the Pandaan District need this opportunity, because it affects agricultural yields and farmers' incomes.

Also, from the results indicated in Table 5, indicator DCL4 had the lowest score of 51.44. This was because, at any slightest opportunity, the average respondents in the Pandaan District are likely to consider selling/converting lands, while still holding on to a preference in protecting agricultural sites. Agricultural landowners in the Pandaan district rely on the lands they own, and are reluctant to convert them because sites to them (landowners) are family inheritance that should be cultivated. However, respondents' incomes are often affected by the output of their agricultural property.

4.2. The relationship between place attachment and the decision to change land

The next step was to analyze the relationship between the place attachment and the decision to change the land, based on the results of

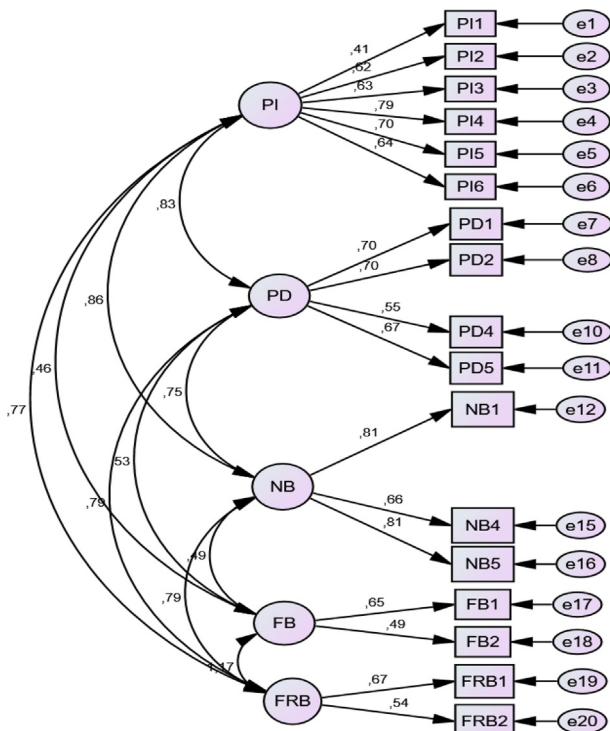

Figure 3. CFA model for place attachment indicator.

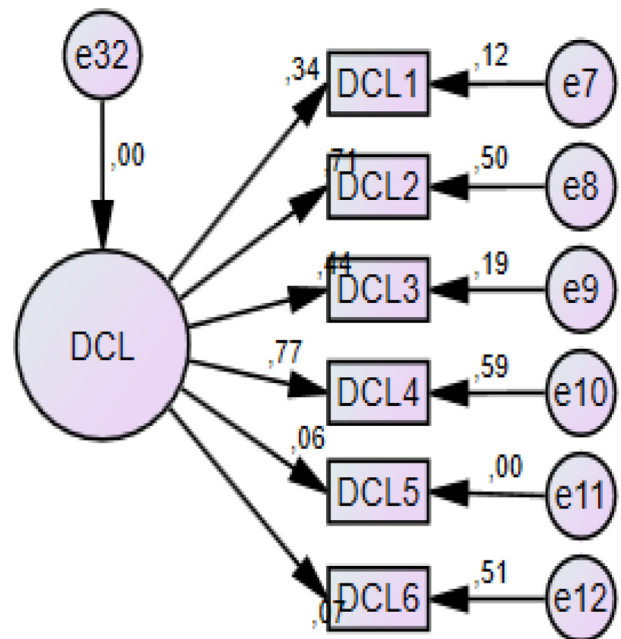

Figure 4. CFA model variable decision to change the land (DCL).

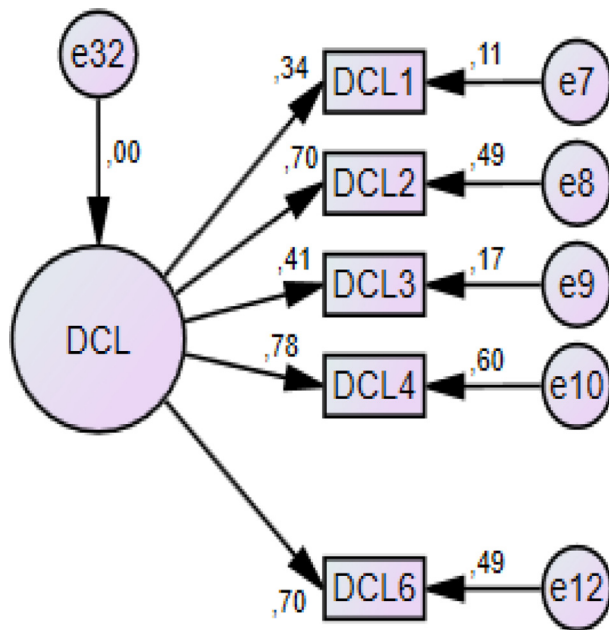

Figure 5. DCL variable CFA model without DCL5 indicator.

the descriptions provided. Structural Equation Modeling (SEM) applied in AMOS software was the research method used, as the SEM was a second-order model. The latent variable (Place Attachment) was also observed to be affected by some sub-variables (Place Identity-PI, Place Dependence-PD, Nature Bonding-NB, Friend Bonding-FRB, and Family Bonding-FB). The following was the product of modeling the relationship between the place attachment and the urge to change the land.

4.2.1. Confirmatory factor analysis (CFA)

CFA analysis was carried out to identify indicators that affected the place attachment dimensions, and maintained land variables. The CFA analysis program used was AMOS 22. Based on CFA results, three indicators with a loading factor of <0.30 , namely NB2 (0.13), NB3 (0.28) and PD3 (0.26) were observed. NB2 indicator "I feel less attached to this village/kelurahan when animals and plants are missing" reflected no place attachment, as almost all respondents agreed that the factor (NB2) had no effect/does not interfere with the PA (Place Attachment) dimension. Also, the NB3 indicator "I understand myself when spending time in this village/kelurahan's natural environment" did not reflect an attachment, as almost all respondents were neutral, as NB3 does not have an effect/interact with the dimension of the location. "I do not want to do things normally carried out in this village/kelurahan otherwise" meant no attachment, because almost all respondents replied neutrally, therefore PD3 had no control/no interplay with the site attachment dimension. The three indicators were further withdrawn, and the CFA was introduced with a new model. Figure 3 showed the CFA results for the Position Focus Indicator, after eliminating NB2, NB3, and PD3 indicators.

Based on the CFA results without indicators NB2, NB3, and PD3, the model was much better than previously. This was observed from the shift of bad to a good fit in the Chi-Square index category, as six of the seven categories were well-fit. Additionally, the indicator loading value was >0.5 , with the exception of FB2 (0.49) and PI1 (0.41). However, both indicators should not be removed, due to the fact that the model was fit, and the FB2 loading factor was close to 0.5. Similarly, the actual PI1 value was not far from 0.5, and the indicator's removal does not change the loading parameters of the other factors significantly, while exacerbating the estimated results for the fit models' index category. Therefore, the CFA model without NB2, NB3, and PD3 indicators was considered the best Position Attachment model.

The removal of both PI1 and FB2 was not performed, although the two indicators' load factor was less than 0.5, because the exclusion of

both deteriorated the model. PI1 indicator "This village means a lot to me" was influenced by the number of memories established in the Pandaan district, with relatives and family, as most respondents provided a high PI1 factor, in a bid for it to affect the place level. FB2 indicator "My relationship with my family in this village/kelurahan is very particular to me", was concerned with the rituals and customs of a large family in the village/kelurahan. This measure affected the degree of attachment in the Pandaan district.

After the knowledge of CFA results on position attachment indicators, the analysis for the variable decision to protect the land was performed afterwards. Figure 4 showed the full CFA model of the Decision to Change the Land (DCL) variable.

Based on the CFA results, it was inferred that its model of variable land maintenance suits the analysis accurately. This inference was based on the good fit estimates of Chi-square, BIC, CAIC, GFI, PGFI, and PRATIO, as it was also near to favorable fitness of RMSEA. The next step was to change each indicator's loading factor influencing the desire for land maintenance.

The loading value appropriateness of the willingness to protect the land, suggested that the indicators DCL1 and DCL5 had a result of <0.5 . Also, there was a loading factor value indicator that was much lower than 0.5, the DCL5, which should be withdrawn. However, in this analysis, the DCL5 predictor was not omitted, in order not to worsen the model's fitness. Figure 5 displayed the CFA model.

Based on the CFA model's suitability in the land retention component without the DCL5 predictor, it was observed that the formerly slightly fit (nearly to fit) was poorly suitable. Other types, such as BIC, PGFI, and PRATIO, were poorly equipped before eliminating DCL5. The DCL5 indicator was therefore not removed initially from the CFA model of defending the region. The DCL5 indicator was deleted, when the overall model, namely the SEM design, was aggravated.

4.2.2. Structural Equation Model (SEM)

The SEM analysis explored the relationship between the position's attachment and the wish to change the territory. The SEM study results were to assess whether the position connection had a substantial positive influence on the urge to change the territory. Also, the SEM model was a second-order model with many variables (situation identity, position dependency, nature bonding, friend bonds, and family bonding's) affecting the latent factor (place attachment). The indicators used were sub-variable indicators that were in line with the results of the CFA study performed. Figure 6 showed the picture of the full SEM model to be used.

The testing of the measuring model was performed using the CFA process. However, CFA analysis had been performed in the previous phases to select a valid variable indicator, with the results of the SEM measurement still containing inaccurate factors, as this stage should also be carried out again. The validity test convergent was also carried out, in order to determine whether the predictor used represented the structural/latent variables. The size of the convergent validity test in this study used the Standardized Loading Factor (SLF) value. Also, Hair et al., was discovered to have designed the standardized loading factor value, which was >0.5 (Hair et al., 2014).

There were number of indicator variables with SLF <0.5 , including PI5 (0.485), PI1 (0.436), DCL1 (0.387), DCL3 (0.431), DCL5 (0.129), PD2 (0.358), and PD1 (0.495), which were yet to be true. The results of the overall model fitness test estimation of the SEM (Goodness of Fit), was shown in Table 6. In the SEM fit model index categories, there were five classes poorly suitable (Chi-Square, RMSEA, BIC, CAIC, and GFI), with only PGFI and RATIO showing good and marginal fitness, respectively.

4.2.3. Fit test and specifications of SEM model

The decision to change the land use was affected by the Standardized Loading Factor (SLF). The result analysis showed that the SLF values of PI, PD, FRB, FB, and NB were 0.967, 0.865, 1.145, 1.491, and 0.884, respectively. The SLF analysis results also met the criteria for

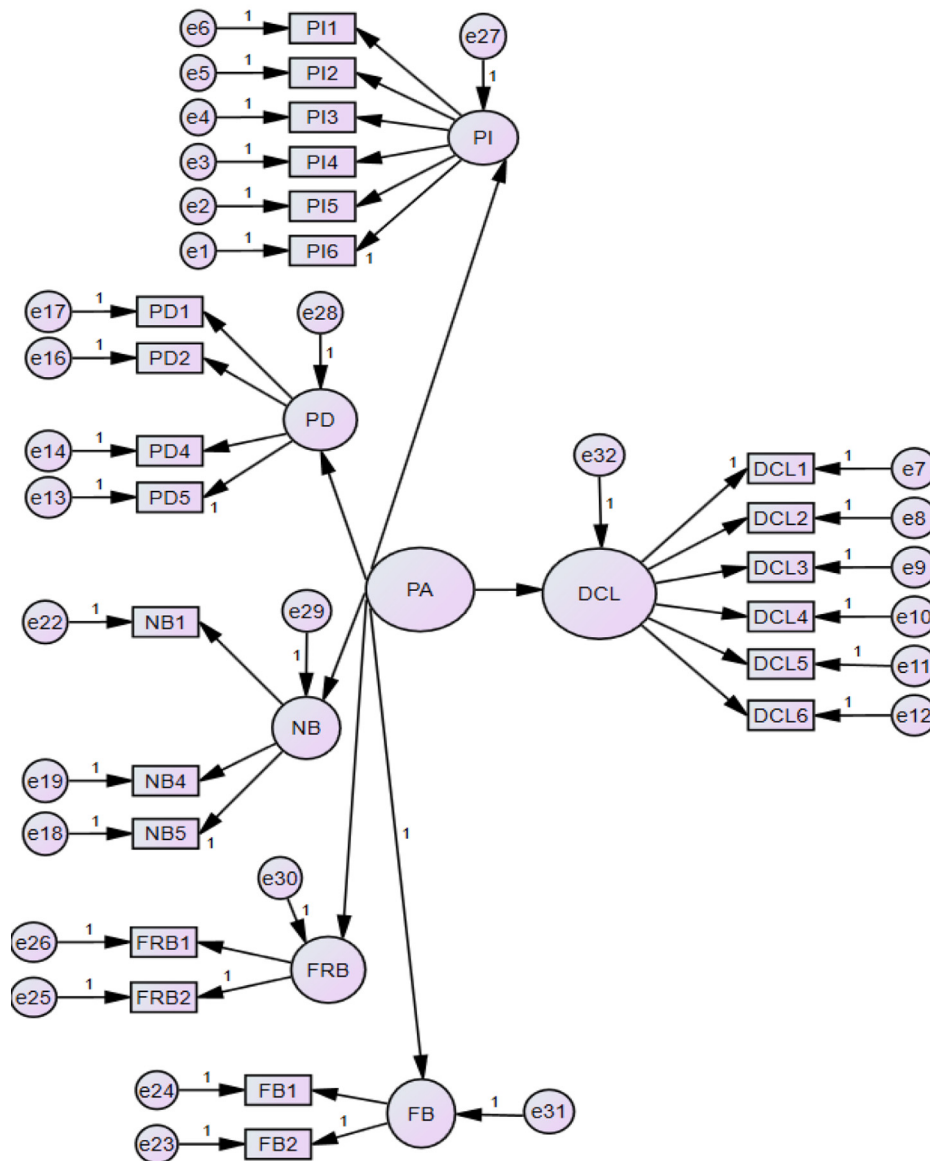

Figure 6. CFA results on place attachment indicators.

the SLF value ≥ 0.5 , as it was concluded that the indicators used were valid or reflected the latent variables of decision to change the land (DCL).

Table 6 showed that the SEM structural model needs to be re-specified, by eliminating invalid indicator variables. This was due to the fact that there were several invalid indicator variables. Provided that

Table 6. CFA model compliance.

Index Category	Cut Off Value	Estimated Value	Information
Chi-Square	< 810	1808,705	Poor fit
RMSEA	$\leq 0,08$	0,125	Poor Fit
BIC	$< \text{BIC Saturated dan Independence Model (Schumacker and Lomax, 2012)}$	2127,189	Poor Fit (Saturated model: 1690,413; Independence model: 4253,801)
CAIC	$\leq \text{CAIC Saturated dan Independence Model}$ $\geq 0,9$	2179,189	Poor Fit (Saturated model: 1966,413; Independence model: 4276,801)
GFI	$\geq 0,60$	0,722	Poor Fit
PGFI	$\geq 0,60$	0,586	Marjinal Fit
PRATIO		0,885	Good Fit

Sources: own calculation.

Table 7. Path coefficients.

Relation	Regression Weight	SE	P	R ²
Place attachment → Decision to Change the Land	0,657	,186	***	0,316

*Note: $p > 0,05$ = not significant (ns); $p < 0,05$ (***) = significant.

three factors had been deleted in the CFA study, this test was also phased out progressively by deleting the indicator variable that had the lowest SLF value (DCL5), in a bid to avoid deleting too many indicators. The DCL5 predictor that does not reflect the latent variable was "I will keep the land when the investors purchased it, even though there were no reward (DCL5)". This was because most respondents did not complete the questionnaire consistently. After extracting the K5 indicator variable, the re-testing was carried out.

After the knowledge of the standardized loading factor (SLF) value of the latent variable indicators, the value of the relationship between the factors of Place Attachment on the Decision to Change Land (DCL) was indicated in Table 7.

The results of the analysis as observed in Table 7, showed that the path coefficient was significant (p : ***), with a regression weight of 0.657. This meant that the Place Attachment provided a positive path coefficient value (0.675) to the Decision to Change the Land. Based on these results, it was clear that the higher the place attachment, the more likely the community was to defend/protect the land.

4.3. Discussions

The analysis results showed that Pandaan District had a high place attachment index. All villages had a high average place attachment index score, i.e., the FB, FRB, PI, NB, and PD scores of 84.98, 83.13, 80.98, 77.98, 77.38, respectively. Also, high family bonding showed that respondents feel close to families living in the same village. The majority of the population in the Pandaan district lived with their families, as they continue to preserve their land and provide shelter, in order to strengthen family ties between the neighbouring relatives. High Friend Bonding also suggested that the respondents were similar to family members in the working environment (with agriculture), and everyday activities. Respondents feel attached by friendship in their location of residence, as they often support one another in everyday activities, like community service, tahlil/Yasinan, Empowerment of Family Welfare Group (PKK-Pemberdayaan Kesejahteraan Keluarga), youth associations (karang taruna), and organization of meetings for village management. A high-place attachment further suggested that the group was already connected to the village they live. The residents enjoy the memories and warmth they obtain when they live in the village. The respondent's high place dependency indicated the feeling of dependence on the village/kelurahan, e.g., where they live and work (farmland there). The high dependence also suggested that the respondents were extremely contented and relaxed with the daily activities in the village/kelurahan. This was in line with the studies of (Flemsæter, 2009; Hildenbrand and Hennon, 2005; Kuehne, 2013), which stated that farmers need a deep commitment to the lands in their lives. Generally, farmers tend to maintain their land deeply and securely, despite the awareness that they were unable to manage their site indefinitely (Cheshire et al., 2013; Flemsæter, 2009; Kuehne, 2013).

Based on the survey results and estimates of the attitude to protect the land, respondents were observed to be neutral. The neutral attitudes were discovered in 15 locations, namely Plintahan, Durensewu, Nogosari, Banjarkejen, Tawangrejo, Sumbergetang, Wedoro, Kemirisewu, and Pandaan villages. Despite having fertile sites, good incomes, and earn incentives, the village/kelurahan owners were still willing to sell or change their land use. The price of land offered by buyers and the increased operating costs depended on this decision. The high price of land, great salaries for agricultural workers, reduced water from drilling wells, and the decreasing rice valuation, has made farmers believe that

farm income was hard to anticipate. The remaining four locations that opted for the protection of land were Banjarsari, Kebonwaris, Petungasari, and Kutorejo Villages. The conditions of fertile land, robust irrigation systems, and farmers working at help and meetings, often made the respondents more attached to farmland, making them unwilling to sell. Furthermore, most respondents had received farmland from the legacy scheme. Owned lands were family heritages to be processed and preserved, which made them unable to be sold/changed.

Indicator DCL1, "When there are incentives, I will protect the land" had the highest score of 79.48, in the variable of willingness to preserve property or land. Farmers in the Pandaan district were encouraged to protect their lands, due to the fact that they have good agricultural sites for cultivation. Also, the indicator DCL4, "I will not protect the land, whether or not there is an opportunity" had the lowest score of 51.44. This meant that when opportunities arise, the average respondent in Pandaan district consider selling/converting their lands, while also preferring to retain them. The owners of farmland in the Pandaan districts relied on their property, due to the fact that their reluctance to conversion, as the lands were family heritage that had to be processed. Agricultural land productivity also determined the income of respondents.

Based on the confirmatory factor analysis (CFA), all measures of place attachment dimension had major effects except the NB2 statement, "I feel less attached when plant and animal are lost in this village". The three statements had responses that did not reflect the dimension of the position connection. The CFA results on the decision to defend land variables had a substantial impact, with all indicators opting for the desire to preserve sites except for the DCL5 assertion, "I will keep the land when the investors purchase it, even though there were no reward". This declaration had a response that did not stand for the decision to protect the land.

Based on the significant test, it was understood that place attachment's path coefficient value was 0.657, which was substantially positive to preserve the land use. The weight value indicated that the place attachment relationship positively impacted the decision to protect the land. The respondents' decision to protect the land was more potent when the place attachment was high. This was in line with the hypothesis that residents with high places often want to safeguard their lands. This was further confirmed by the R² value of 0.316, which meant that the place attachment affected 31.6% of the variance in preserving the land use. These results supported this study hypothesis that, the stronger the place attachment, the lesser the attitude and decision to change the land used. This encourages the retention of agricultural land, therefore making agriculture in Pandaan District more sustainable. This was also in line with the results of (Raymond et al., 2017; Walker and Ryan, 2008), which stated that people with high level of commitments were more tolerant of land management policies, in order to conserve rural sites, and while also protecting people that possess strong connection to their places of residence. Also, the results of (Budruk et al., 2009), stated that people feeling committed to the places they live, should be mindful of preserving their environment.

5. Conclusions

The results showed that Pandaan District had a high place attachment index. In the Pandaan district, all villages had high average attachment scores of 84.98, 83.13, 80.98, 77.98, and 77.38 for FB, FRB, PI, NB, and PD, respectively. This meant that place attachment had a relationship with the decision to preserve or protect land.

The decision to preserve the land was also affected by the Standardized Loading Factor (SLF) of PI, PD, FRB, FB, and NB values, at 0.967,

0.865, 1.145, 1.491, and 0.884, respectively. The place identity indicated that the respondent felt that their village of residence was very important. Most respondents were Pandaan people that have been living in the village/kelurahan since birth, therefore enforcing their tendency to protect lands.

The results of the Structural Equation Modeling (SEM) demonstrated the relationship between the connection to the place and attitude to protect the land. The attitude towards land development had a weight of 0.657, which was substantially optimistic. The weight value further indicated that the place attachment relationship positively impacted the decision to maintain land, i.e., the higher the willingness to manage sites, the more the connection of the location. These results were accompanied by a 31.6% value of R², meaning that the place attachment influenced 31.6% of the variance, in the decision to preserve or protect the land.

Declarations

Author contribution statement

Gunawan Prayitno: Conceived and designed the experiments; Analyzed and interpreted the data; Wrote the paper.

Achmad Tjahja Nugraha: Performed the experiments.

Dian Dinanti, Izzatul Ihsansi Hidayana: Analyzed and interpreted the data.

Funding statement

This research did not receive any specific grant from funding agencies in the public, commercial, or not-for-profit sectors.

Data availability statement

Data will be made available on request.

Declaration of interests statement

The authors declare no conflict of interest.

Additional information

No additional information is available for this paper.

Acknowledgements

This research was supported by the project, which has received funding from the Brawijaya University research program for Assitant Professor Research Grant, Grant Agreement Number 89/UN10.FO7/PN/2020.

References

- Agus, F., Irawan, 2006. Agricultural land conversion as a threat to food security and environmental. *Jurnal Penelitian Dan Pengembangan Pertanian* 25 (3), 90–98.
- Antrop, M., 2000. Changing patterns in the urbanized countryside of Western Europe. *Landsc. Ecol.* 15 (3), 257–270.
- Ashari, N., 2016. Tinjauan tentang alih fungsi lahan Sawah ke non Sawah dan Dampaknya di Pulau Jawa. *Forum Penelitian Agro Ekonomi* 21 (2), 83.
- Basuki, C., Purwanto, J., Fajarningsih, R.U., Ani, S.W., 2010. Dampak alih fungsi lahan Pertanian Ke Sektor non pertanian Terhadap Ketersediaan Beras di Kabupaten Klaten Provinsi Jawa Tengah. *J. Sustain. Agric.* 25 (1), 38.
- Brown, B., Perkins, D.D., Brown, G., 2004. Place attachment in a revitalizing neighborhood: individual and block levels of analysis. *J. Environ. Psychol.* 24 (1), 259–271.
- Brown, G., Raymond, C.M., Corcoran, J., 2015. Mapping and measuring place attachment. *Appl. Geogr.* 57, 42–53.
- Bryan, B.A., 2013. Incentives, land use, and ecosystem services: synthesizing complex linkages. *Environ. Sci. Pol.* 27, 124–134.
- Budruk, M., Thomas, H., Tyrrell, T., 2009. Urban green spaces: a study of place attachment and environmental attitudes in India. *Soc. Nat. Resour.* 22 (9).
- Canter, D., 1977. *The Psychology of Place*. The Architectural Press Ltd.
- Chen, N., Hall, C.M., Yu, K., Qian, C., 2019. Environmental satisfaction, residential satisfaction, and place attachment: the cases of long-term residents in rural and urban areas in China. *Sustainability (Switzerland)* 11 (22).
- Cheshire, L., Meurk, C., Woods, M., 2013. Decoupling farm, farming and place: recombinant attachments of globally engaged family farmers. *J. Rural Stud.* 30, 64–74.
- Collins-Kreiner, N., 2020. Hiking, sense of place, and place attachment in the age of globalization and digitization: the Israeli case. *Sustainability* 12 (11).
- Curran-Cournane, F., Cain, T., Greenhalgh, S., Samarsinghe, O., 2016. Attitudes of a farming community towards urban growth and rural fragmentation—An Auckland case study. *Land Use Pol.* 58, 241–250.
- Davis, J.L., Green, J.D., Reed, A., 2009. Interdependence with the environment: commitment, interconnectedness, and environmental behavior. *J. Environ. Psychol.* 29 (2), 173–180.
- Dewi, I., Sarjana, I., 2015. Faktor-faktor pendorong Alihfungsi lahan Sawah Menjadi lahan non-Pertanian (Kasus: Subak Kerdung, Kecamatan Denpasar Selatan). *Jurnal Manajemen Agribisnis* 3 (2), 26303.
- Ernawati, J., 2014. Hubungan aspek residential dengan place identity dalam Skala urban. *J. Environ. Eng. Sustain. Technol.* 1 (1), 21–32.
- Fitrianiatsany, 2017. Urban desa proses Transisi Desa Menjadi Kota. *Sosiol. Agama: J. Ilm. Sosiol. Agama Dan Perubahan Sosial.* 11 (2), 185–208. <http://ejournal.uin-suka.ac.id/ushuluddin/SosiologiAgama/article/download/112-03/1185>.
- Flemonsæter, F., 2009. Home matters: the role of home in property enactment on Norwegian smallholdings. *Norsk Geogr. Tidsskr. - Nor. J. Geogr.* 63 (3), 204–214.
- Ganji, S.F.G., Johnson, L.W., Sadeghian, S., 2020. The effect of place image and place attachment on residents' perceived value and support for tourism development. *Curr. Issues Tourism* 1–15.
- Hair, J.F., Sarstedt, M., Hopkins, L., Kuppelwieser, V.G., 2014. Partial least squares structural equation modeling (PLS-SEM): an emerging tool in business research. *Eu. Business Rev.* 26 (2), 106–121.
- Halpenny, E.A., 2010. Pro-environmental behaviours and park visitors: the effect of place attachment. *J. Environ. Psychol.* 30 (4), 409–421.
- Hildenbrand, B., Hennon, C., 2005. Above all, farming means family farming: context for introducing the Articles in this special issue. *J. Comp. Fam. Stud.* 36 (4), 357–366.
- Hinds, J., Sparks, P., 2008. Engaging with the natural environment: the role of affective connection and identity. *J. Environ. Psychol.* 28 (2), 109–120.
- Iaquina, D.L., Drescher, A.W., 2000. Defining the peri-urban: rural-urban linkages and institutional connections. *Land Reform, Land Sett. Coop.* 2 (January), 8–26.
- Irawan, B., 2008. Meningkatkan Efektifitas Kebijakan Konversi lahan. *Forum Penelitian Agro Ekonomi* 26 (2), 116–131.
- Jorgensen, B.S., Stedman, R.C., 2001. Sense of place as an attitude: lakeshore owners attitudes toward their properties. *J. Environ. Psychol.* 21 (3), 233–248.
- Kuehne, G., 2013. My decision to sell the family farm. *Agric. Hum. Val.* 30 (2), 203–213.
- Kusumastuti, A.C., Kolopaking, L.M., Barus, B., 2018. Factors affecting the conversion of agricultural land in pandeglang regency. *Sodality: J. Sosiol. Pedesaan* 6 (2).
- Lin, C.C., Lockwood, M., 2014. Forms and sources of place attachment: evidence from two protected areas. *Geoforum* 53, 74–81.
- Lokocz, E., Ryan, R.L., Sadler, A.J., 2011. Motivations for land protection and stewardship: exploring place attachment and rural landscape character in Massachusetts. *Landsc. Urban Plann.* 99 (2), 65–76.
- Maladi, Y., 2013. Kajian hukum kritis alih fungsi lahan hutan berorientasi kapitalis. *Dln. Huk.* 13, 109–123.
- Manstead, A.S.R., 2011. The benefits of a critical stance: a reflection on past papers on the theories of reasoned action and planned behaviour. *Social Psychol.* 50 (3), 366–373.
- Nassauer, J.I., 2011. Care and stewardship: from home to planet. *Landsc. Urban Plann.* 100 (4), 321–323.
- Nunkoo, R., Ramkissoon, H., 2012. Structural equation modelling and regression analysis in tourism research. *Curr. Issues Tourism* 15 (8), 777–802.
- Pannell, D.J., 2006. Using incentives to buy land-use change in agriculture for environmental benefits environmental benefits. *Inter. Asso. Agricult. Econ. Conf.* February 2006 1–16.
- Pasuruan, B.P.S., 2020. Pasuruan in Figure 2020. <https://pasuruankab.bps.go.id/publication/2019/08/16/9ebe327b25852ba77d32a661/kabupaten-pasuruan-dalam-angka-2019.html>.
- Perlindungan Lahan Pertanian Berkelanjutan, 204, 2009.
- Prawira, N., Ariastita, P., 2014. Rumusan insentif dan disinsentif pengendalian. *J. Tekn. Pomis* 3 (2).
- Prayag, G., Ryan, C., 2011. Antecedents of tourists' loyalty to Mauritius: the role and influence of destination image, place attachment, personal involvement, and satisfaction. *J. Trav. Res.* 51 (3), 342–356.
- Prayitno, G., Subagiyo, A., 2018. *Membangun Desa*. UB Press.
- Prayitno, G., Hidayat, A.R.T., Subagiyo, A., Paramasasi, N.K., 2018. Factors that effect to land use change in Pandaan District. In: *IOP Conference Series: Earth and Environmental Science*.
- Prayitno, G., Sari, N., Hidayat, A.R.T., Nyoman Widhi, S.W., Dwi Maulidatuz, Z., 2019. Soil/land use changes and urban sprawl identification in Pandaan District, Indonesia. *Inter. J. Geom.* 16 (53).
- Prayitno, G., Subagiyo, A., Rusmi, S., Evelina, 2019. *Perencanaan Desa Terpadu: Modal Sosial Dan Perubahan Lahan*, first ed. AE Medika Grafika.

- Prayitno, G., Dinanti, D., Rusmi, S.A., Surjono, Dwi Maulidatuz, Z., 2019. Place attachment index of landowners in pandaan sub-district, pasuruan regency, Indonesia. In: IOP Conference Series: Earth and Environmental Science.
- Prayitno, G., Sari, N., Hasyim, A.W., Nyoman, S.W., 2020. Land-use prediction in Pandaan District pasuruan regency. *Inter. J. Geom.* 18 (65), 64–71.
- Prayitno, G., Ahari, M.I., Rukmi, W.I., 2021. Structural equation model with partial least square (SEM-PLS) of place dependence with land used change. *J. Inter. Stud.* 14 (1), 153–171.
- PUSPIJAK and FFCPF, 2012. Analisis Time Series Faktor-Faktor Sosial Ekonomi Dan Kebijakan Terhadap Perubahan Penggunaan Lahan Analisis Time Series Faktor-Faktor Sosial Ekonomi Dan Kebijakan Terhadap Perubahan Penggunaan Lahan.
- Putra, A.M., 2006. Konsep desa Wisata. *J. Manajem. Pariwisata.*
- Quinn, C.E., Carolina, S., States, U., Halfacre, A.C., 2014. Place matters: an investigation of farmers' attachment to their land. *Hum. Ecol. Rev.* 20 (2), 117–133.
- Ramkissoon, H., Weiler, B., Smith, L.D.G., 2012. Place attachment and pro-environmental behaviour in national parks: the development of a conceptual framework. *J. Sustain. Tourism* 20 (2), 257–276.
- Ramkissoon, H., Graham Smith, L.D., Weiler, B., 2013. Testing the dimensionality of place attachment and its relationships with place satisfaction and pro-environmental behaviours: a structural equation modelling approach. *Tourism Manag.* 36, 552–566.
- Raymond, C.M., Brown, G., Weber, D., 2010. The measurement of place attachment: personal, community, and environmental connections. *J. Environ. Psychol.* 30 (4), 422–434.
- Raymond, C.M., Kytta, M., Stedman, R., 2017. Sense of place, fast and slow: the potential contributions of affordance theory to sense of place. In: *Frontiers in Psychology*, 8, p. 1674. <https://www.frontiersin.org/article/10.3389/fpsyg.2017.01674>.
- Rondhi, M., Pratiwi, P.A., Handini, V.T., Sunartomo, A.F., Budiman, S.A., 2018. Agricultural land conversion, land economic value, and sustainable agriculture: a case study in East Java, Indonesia. *Land* 7 (4).
- Scannell, L., Gifford, R., 2010. Defining place attachment: a tripartite organizing framework. *J. Environ. Psychol.* 30 (1), 1–10.
- Schumacker, R., Lomax, R.G., 2012. *A Beginner's Guide to Structural Equation Modelling*. Routledge, Taylor and Francis Group.
- Stedman, R.C., 2003. Is it really just a social construction?: the contribution of the physical environment to sense of place. *Soc. Nat. Resour.* 16 (8), 671–685.
- Stedman, R., Beckley, T., Wallace, S., Ambard, M., 2004. A picture and 1000 words: using resident-employed photography to understand attachment to high amenity places. *J. Leisure Res.* 36 (4), 580–606.
- Stedman Richard, C., 2003. Is it really just a social construction?: the contribution of the physical environment to sense of place. *Soc. Nat. Resour.* 16 (8), 671–685.
- Subagiyo, A., Prayitno, G., Kusriyanto, R., 2020. Alih fungsi lahan pertanian ke-non Pertanian di Kota Batu Indonesia. *Geography* 8 (2), 135–150.
- Sugiyono, 2016. *Memahami Penelitian Kualitatif*. Bandung: Alfabeta.
- Trentelman, C.K., 2009. Place attachment and community attachment: a primer grounded in the lived experience of a community sociologist. *Soc. Nat. Resour.* 22 (3), 191–210.
- Tveit, M., Ode, Å., Fry, G., 2006. Key concepts in a framework for analysing visual landscape character. *Landsc. Res.* 31 (3), 229–255.
- Walker, A., Ryan, R., 2008. Place attachment and landscape preservation in rural New England: a Maine case study. *Landsc. Urban Plann.* 86 (2), 141–152.
- Wiles, J.L., Rolleston, A., Pillai, A., Broad, J., Teh, R., Gott, M., Kerse, N., 2017. Attachment to place in advanced age: a study of the LiLACS NZ cohort. *Soc. Sci. Med.* 185, 27–37.
- Wrachien, D.De, 2003. Land use planning: a key to sustainable agriculture. In: Torres L, G., J. B., A. M.-V., Holgado-Cabrera, A. (Eds.), *Conservation Agriculture*. Springer, Dordrecht.
- Xu, G., Li, Y., Hay, I., Zou, X., Tu, X., Wang, B., 2019. Beyond place attachment: land attachment of resettled farmers in Jiangsu, China. *Sustainability (Switzerland)* 11 (2), 1–12.
- Yoon, C.G., 2009. Wise use of paddy rice fields to partially compensate for the loss of natural wetlands. *Paddy Water Environ.* 7 (4), 357.
- Zhang, B., Sun, P., Jiang, G., Zhang, R., Gao, J., 2019. Rural land use transition of mountainous areas and policy implications for land consolidation in China. *J. Geogr. Sci.* 29 (10), 1713–1730.