

A prospective study of neurological outcome in relation to findings of imaging modalities in acute spinal cord injury

Roop Singh, Rohilla Rajesh Kumar, Nishant Setia, Sarita Magu¹

Departments of Orthopaedic Surgery, Paraplegia and Rehabilitation and ¹Radiodiagnosis, Pt. B.D. Sharma PGIMS, Rohtak, Haryana, India

ABSTRACT

Aim: The aim was to correlate the clinical profile and neurological outcome with findings of imaging modalities in acute spinal cord injury (SCI) patients.

Subjects and Methods: Imaging (radiographs, computed tomography [CT], and magnetic resonance imaging [MRI]) features of 25 patients of acute SCI were analyzed prospectively and correlated with clinical and neurology outcome at presentation, 3, 6 and 12 months.

Results: Average initial sagittal index, Gardner's index, and regional kyphosis were 8.12 ± 3.90 , 15.68 ± 4.09 , 16.44 ± 2.53 , respectively; and at 1-year were 4.8 ± 3.03 , 12.24 ± 4.36 , 12.44 ± 2.26 , respectively. At presentation patients with complete SCI had significantly more compression percentage (CP) ($P < 0.001$), maximum canal compromise ($P < 0.001$), maximum spinal cord compression ($P < 0.001$), in comparison to incomplete SCI patients. Qualitative MRI findings; hemorrhage, cord swelling, stenosis showed a predilection toward complete SCI. Improvement in canal dimensions ($P = 0.001$), beck index ($P = 0.008$), spinal cord edema ($P = 0.010$) and stenosis ($P = 0.001$) was more significant in patients managed operatively; but it was not associated with improved neurological outcome. Cord edema was found more in incomplete SCI patients. Patients presenting with complete SCI improved neurologically to a lesser extent.

Conclusions: The present study concludes that imaging modalities in spinal cord injuries have a major role in diagnosis, directing management and predicting prognosis. Imaging findings of severe kyphotic deformities, higher canal and cord compression, lesion length, hemorrhage, and cord swelling are associated with poor initial neurological status and recovery. Quantitative and qualitative parameters measured on MRI have a significant role in predicting initial severity of neurological status and outcome. Operative intervention helps in improving few of these imaging parameters, but not ultimate neurological outcome. MRI is an excellent modality to evaluate acute SCI, and MR images obtained in the acute period significantly and usefully predict neurological outcome.

Key words: Magnetic resonance imaging, neurological outcome, spinal cord injury

Introduction

Acute traumatic spinal cord injury (SCI) represents one of the most devastating injuries to afflict the human body. The

injury has a high rate of prevalence in the younger population, creating physical, emotional, and economic burdens on both the individual and society.^[1] The priority in any case of suspected spinal injury is to assess the spine as quickly, accurately and comprehensively as possible for acute injuries or instability. However, a significant proportion of patients presenting to accident and emergency department with suspected spinal injury are obtunded or incapable of undergoing a satisfactory neurological examination for one reason or another. In such patients, the primary investigation to rule out spinal injury is usually some form of cross-sectional imaging.^[2]

Plain radiography, computed tomography (CT), and magnetic resonance imaging (MRI) may all be used in the evaluation of the spinal column and are often complementary. Conventional radiography is the first line imaging investigation in most spinal trauma clearance protocols, and a large proportion

Access this article online	
Quick Response Code:	Website: www.asianjns.org
	DOI: 10.4103/1793-5482.161166

Address for correspondence:

Prof. Roop Singh,
Departments of Orthopaedic Surgery, Paraplegia and Rehabilitation,
Pt. B.D. Sharma PGIMS, Rohtak - 124 001, Haryana, India.
E-mail: drroopsingh@rediffmail.com

of patients, particularly those who are neurologically intact with a normal Glasgow coma scale, very often do not require further imaging.^[2] In the setting of acute spinal trauma, CT scan has been shown to be more time efficient and significantly more sensitive for fracture detection than plain films.^[3-5] MRI, with superior tissue characterization, provides the best evaluation of soft tissue pathology and essentially the only direct evaluation of the spinal cord. Information obtained regarding discs, ligaments, hematoma, and the spinal cord is often complementary to the evaluation of osseous pathology provided by CT scan.^[6] MRI is indicated in the setting of spinal trauma when a neurologic deficit is present or when there is clinical suspicion of a soft tissue or vascular abnormality.^[6,7]

There is a great propensity for recovery after SCI. An examination of the anatomic basis of recovery indicates that there is a potential for both root and cord recovery, with the latter involving recovery of both gray and white matter of the cord. Resolution of acute injury events, such as hemorrhage, and resolution of secondary pathophysiological processes, such as ischemia and excitotoxicity, can each account for recovery. The third recovery mechanism involves regrowth or regeneration of nervous tissue, resulting from either inherent or induced processes.^[8] As the number of patients with SCI are increasing day by day, the information on the outcome helps in counseling the anxious relatives, forecasting length of stay and expenditure in the hospital. The present study aims to analyze findings on imaging modalities in acute spinal injury patients and correlate those with the clinical profile and neurological recovery.

Materials and Methods

This prospective study was conducted between May 2011 and December 2013 and patients with acute traumatic spinal injuries were included in the study. Detailed history with respect to age, sex, mode of trauma, date of trauma and examination was carried out. Twenty-five patients of spinal trauma formed the study group in a prospective fashion. All patients underwent X-rays, CT and MRI examination initially and subsequent follow-ups. Exclusion criteria were patients with severe co-existent other systemic injuries; concomitant head injury and Glasgow coma scale score <15; noncooperative patient; and patients with at least one absolute contraindication (metallic implants, claustrophobia, pacemakers, and cochlear implants *in situ*).

Clinical assessment of spinal cord injury

Clinical assessment (sensory score, motor score and zone of partial preservation) was done at the time of admission, 3rd day, 7th day, 3 months, 6 months and 1-year as per international guidelines^[9] Traumatic SCI was classified into five categories on the American Spinal Injury Association (ASIA) impairment scale (AIS).^[10]

Plain roentgenogram examination (lateral, anteroposterior film) was done. Routine laboratory investigation such as hemoglobin, bleeding time, clotting time, urine complete examination, blood urea, blood sugar, serum electrolytes, electrocardiogram, chest roentgenogram were done in all cases. CT and MRI were done in all cases within 48 h of injury. Patients with cervical spine injury were initially given Philadelphia cervical collar, and cervical traction was applied only after getting MRI done. Patient needing surgery for unstable vertebral column injuries was operated as per requirement.

Follow-up

Follow-up was done at 3 months, 6 months and 1-year. Clinical evaluation and plain radiography were done at each follow-up. CT scan was done at 1-year follow-up. MRIs were done at 3 months, 6 months, 1-year follow-up. Neurological recovery was documented as per ASIA AIS and following the outcome were measured and assessed:

A. Radiological outcome

The following radiological measurements were done in subsequent follow-ups:

Kyphotic deformities (on sagittal view X-ray) [Figure 1]

Sagittal index

Sagittal index (SI) was defined as the measurement of segmental kyphosis at the level of vertebrae involved adjusted for the baseline sagittal contour at the level in the normal spine. It was calculated as the kyphotic deformity (KD) at the fracture motion segment level minus the normal contour (NC) ($SI = KD - NC$). As an estimate of the baseline sagittal curve/level, an angle of 5° was used in the thoracic segments, 0° at the thoracolumbar junction and 10° in lumbar segments.^[11]

Regional kyphosis

It was measured by the angle, formed by the lines drawn on the superior end plate of the normal upper vertebrae and the inferior end plate of the lower normal vertebrae.^[11]

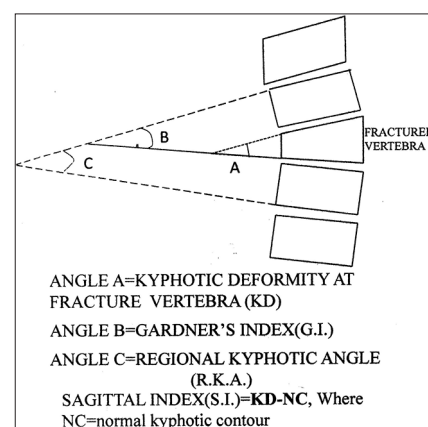

Figure 1: Diagrammatic representation of calculation of kyphotic deformities

Gardner segmental kyphotic deformity

It was measured as the angle formed from lines drawn on the lower end plate of the adjacent normal vertebrae.^[11]

Compression percentage of the height of fractured vertebrae^[11] [Figure 2]

It was calculated by the formula $CP = 100 - F / (A + B / 2) \times 100$, where F was the anterior vertebral height at the fracture level, A and B were the anterior vertebral heights of vertebrae one level above and below the fractured vertebrae, respectively.

Beck index [Figure 2]

It was measured as the ratio of anterior and posterior heights of fractured vertebrae.

Canal dimensions

It was measured by CT of the spine. Maximum anteroposterior (AP) diameter of the canal was measured in sagittal section at the level of fractured vertebrae. Canal compromise was expressed in percentage compromise; by taking mean of the AP diameters of canal in the two normal adjacent vertebrae (one on either side of fractured vertebrae) as normal canal diameter.

Cord compression

It was measured on MRI as per following criteria:

- (a) Quantitative criteria: Three quantitative measures were used: Maximum canal compromise (MCC), maximum spinal cord compression (MSCC) and length of lesion. Mid-sagittal T1-weighted and T2-weighted imaging were used to determine the MCC and MSCC, respectively as described by Fehlings *et al.*^[12] These values were determined by measuring the distance of the canal or spinal cord one segment above and below the lesion, respectively to calculate the average distance. The distance was then measured at the site of the lesion and was expressed as a percentage of the average. The length of the lesion was determined on T2-weighted

images. This length was determined as the distance between the most cephalic and most caudal extent of the lesion.

- (b) Qualitative criteria: The qualitative MRI findings that was used in addition to the quantitative variables, as determined by T2-weighted imaging, included cord hemorrhage, cord edema, cord swelling, spinal stenosis, disc herniation and soft tissue injury (STI), epidural hematoma, body fracture, altered marrow signal, posterior element fracture, supraspinous and interspinous ligament injury, prevertebral edema, spondylolisthesis, luxation, spondylosis, foreign body.

B. Neurologic outcome

It was assessed after doing neurological examination on each follow-up. Any increase in motor power; regain of bladder sensation; bladder and bowel recovery were noticed, and the patients were graded as per ASIA score.^[10]

Statistical methods

To describe strength of association between the extent of SCI and initial neurological status, chi-square test was used. Pearson's Chi-square (χ^2) statistics was applied to test the association between two categorical variables. To assess changes in various parameters with time, Friedman test or independent sample *t*-test was used. The difference was considered to be significant if $P < 0.05$.

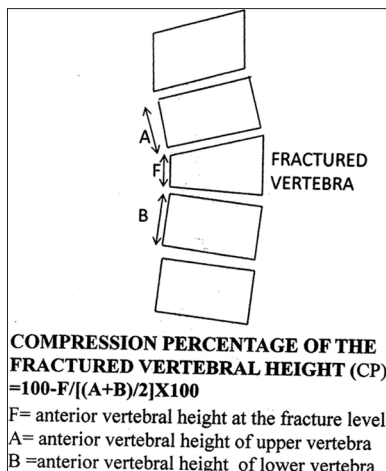

Figure 2: Diagrammatic representation of calculation of compression percentage of the fractured vertebral height

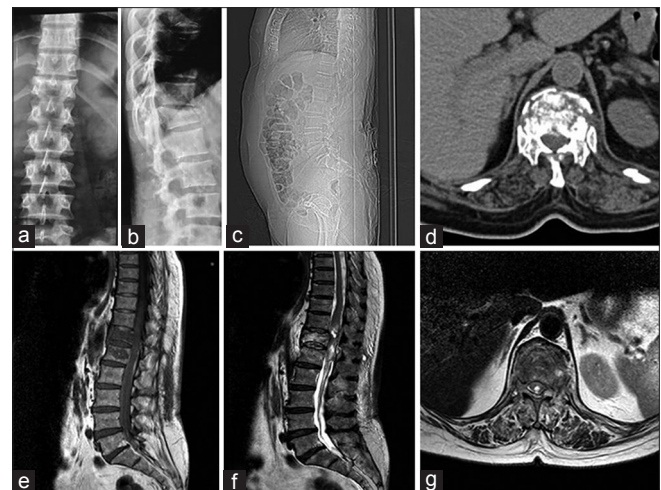

Figure 3a: A 65-year-old female had a road side accident 28 h prior to investigations. Clinical examination showed initial AIS Grade A. Radiograph, computed tomography (CT), and magnetic resonance imaging (MRI) features at the time of initial presentation. (a and b) Plain radiograph (anteroposterior and lateral views) shows wedge collapse of the D12 vertebra. Radiological measurements showed sagittal index, Gardner's index, and regional kyphosis values of 7°, 14°, and 15° respectively. CT scan measurements showed canal dimensions, compression percentage, and Beck index values of 15.21, 6%, and 0.95, respectively. (c and d) MRI sagittal T1-weighted, (e) sagittal T2-weighted, (f) and axial T2-weighted (g) images show maximum spinal cord compression, maximum canal compromise, and lesion length values of 23%, 43%, and 86.06 mm respectively. Hemorrhage, cord swelling, soft tissue injury, body fracture, altered marrow signal, and posterior ligamentous complex injury are also present

Results

Table 1 shows the neurological assessment from the time of presentation to subsequent follow-ups. The average ASIA neurological grade at initial presentation was 3.08 which improved by 0.64 by 3 months and 0.28 by next 3 months and by 0.08 by next 6 months (at 1-year). There was improvement of average 1.0 grade in neurological status from initial to final follow-up. Four (19%) patients did not improve, 10 (47.6%) patients improved by one grade, 6 (28.6%) patients improved by two grades and 1 (0.04%) patient improved by three grades. Four patients were having no deficit (Asia score E) at the time of presentation. Neurological recovery was more in patients with an incomplete injury than complete injury patients.

Table 2 shows radiological parameters from the time of presentation to subsequent follow-ups. Average correction of 3.32° (40.9%) was observed at 3 months follow-up for SI, no further correction was observed on subsequent follow-up. Hence, the average SI achieved at final follow-up was 59% of the initial deformity. Patients with SI >10° were observed to have incomplete SCI. In patients with SI <10° at the time of admission, neurological deficit was present in 15 patients. Neurological improvement was noted in 13 patients (86.7%), and no improvement was noted in 2 patients (13.3%) in patients with SI <10°. Average correction of 3.2° (20.4%) was observed at 3 months follow-up for Gardner segmental KD, further correction of 0.32° at 6 months follow-up, followed by deterioration of 0.08° at 1-year follow-up. Hence, the average Gardner's index achieved at final follow-up was 78% of the initial deformity. Patients with Gardner's KD >20° were observed to have incomplete SCI. Gardner's index 11°–20° was present in 21 of 25 patients – 84% patients. In patients with Gardner's index 11°–20° at the time of admission, neurological deficit was present in 17 patients. Neurological improvement was noted in 14 patients (82.4%), and no improvement was noted in three patients (17.6%). Average correction of 3.44° (21%) was observed at 3 months follow-up for regional KD, further correction of 0.16° at 6 months follow-up, further correction of 0.40° at 1-year follow-up. Hence, the average regional kyphosis achieved at final follow-up was 75.6% of the initial deformity. Patients with regional kyphosis >100 were observed to have incomplete SCI.

Table 3 shows CT scan parameters from the time of presentation to subsequent follow-ups. Average canal dimensions (AP) was 9.64 ± 3.35 mm initially which improved to 13.61 ± 1.61 mm at 1-year follow-up. Improvement in canal dimensions was particularly significant in operatively managed patients [Table 4]. Canal dimensions (AP) <10 mm was present in 14 (56%) of 25 patients. In patients with canal dimensions <10 mm at the time of admission, neurological deficit was present in 12 patients. Neurological improvement was noted

Table 1: Neurological assessment of the study population from initial presentation to subsequent follow-ups

Neurological assessment	Initial	3 months	6 months	12 months
ASIA score				
A	8	1	1	1
B	0	0	0	0
C	3	8	6	6
D	10	12	9	7
E	4	4	9	11
Decreased muscle tone	17	15	11	9
MIS-LL	27.76±21.76	33.48±18.40	37.56±16.48	38.24±15.88
VAC	0.4±0.81	0.76±0.92	1.36±0.7	1.64±0.63
SIS-light touch	77.84±36.67	85.92±34.29	92.52±33.83	98.24±27.44
SIS-pin prick	82.04±35.73	89±33.66	94.92±30.12	99.44±25.53
Absent temperature sense	15	12	2	0
DAP (absent)	21	13	5	2
Superficial reflexes (absent)	20	0	0	0
Deep knee reflex (absent)	14	14	11	11
Deep ankle reflex (absent)	19	19	15	15
Clonus	0	0	0	0
ZPP	0	0	0	0

ASIA – American spinal injury association; MIS – Motor index score; VAC – Voluntary anal contraction; SIS – Sensory index score; DAP – Deep anal pressure; ZPP – Zone of partial preservation

Table 2: Radiological parameters from the time of presentation to subsequent follow-ups

Deformity	Initial	3 months	6 months	1-year
Sagittal index	8.12±3.90	4.8±2.61	4.8±2.87	4.8±3.03
Gardner segmental kyphotic deformity	15.68±4.09	12.48±3.72	12.16±4.15	12.24±4.36
Regional kyphosis	16.44±2.53	13±1.78	12.84±2.11	12.44±2.26

in 10 patients (83.3%) and no improvement was noted in 2 patients (16.7%) in patients with canal dimensions <10 mm. The average CP of the fractured vertebrae was 42% ± 0.24% initially which improved to 28% ± 0.24% (by 33%) by 1-year. CP was more in patients with complete SCI in comparison to incomplete injury as well as neurologically healthy patients [Table 5]. Average beck index was 0.632 ± 0.32 initially and 0.50 ± 0.29 at 1-year follow-up. Average correction of 0.132 was achieved. Correction achieved was particularly significant in operatively managed patients [Table 4].

Table 6 shows MRI parameters from the time of presentation to subsequent follow-ups. Average MSCC was initially 34 ± 0.31 which improved to 19 ± 0.21 (by 44%) in 3 months. It further improved by 12% in next 3 months and improved by 12% in next 6 months (at 1-year) follow-up. Patients with complete injury

had more MSCC in comparison to incomplete injury as well as neurologically healthy patients [Table 5]. MSCC >50% was present in 8 (32%) of 25 patients. In patients with MSCC >50% at the time of admission, neurological deficit was present in all patients. Neurological improvement was noted in 7 patients (87.5%), and there was no improvement in 1 patient (12.5%). Average MCC was $54\% \pm 0.3\%$ initially which improved to 30 ± 0.23 (by 44%) in 3 months. It further improved by 11% in next 3 months and by 9% in next 6 months (at 1-year) follow-up. Patients with complete injury had more MCC in comparison to incomplete injury as well as neurologically healthy patients. MCC >50% was present in 12 (48%) of 25 patients. In patients with MCC >50% at the time of admission, neurological deficit was present in 11 patients. Improvement was noted in 9 patients (81.8%), and no improvement was noted in 2 patients (18.2%). Average lesion length in our subjects was 25.25 ± 29.55 mm initially which improved to 18.15 ± 22.75 (by 28%) in 3 months. It further improved by 19% in next 3 months and by 16.4% in next 6 months (at 1-year) follow-up. Decrease in lesion length was particularly significant in patients managed operatively [Table 4]. Lesion length >50 mm was present in 6 (24%) of 25 patients. In patients with lesion length >50 mm at the time of admission, neurological deficit was present in 5 patients. Neurological improvement was

noted in 4 patients (80%), and no improvement was noted in 1 patient (20%) with lesion length >50 mm. Spinal cord edema was present in 13 patients initially and in 7 patients at 1-year follow-up. Patients with spinal cord edema showed a predilection toward incomplete SCI at presentation. Patients managed operatively were observed to have significant resolution of edema. In patients with edema at the time of admission, neurological deficit was present in 11 patients. Neurological improvement was noted in 10 patients (90.9%), and there was no improvement in 1 patient (9.1%). Patients with hemorrhage initially had a severe neurological deficit at presentation. In patients with hemorrhage at the time of admission, improvement was noted in 3 patients (75%), and no improvement was noted in 1 patient (25%). Patients with Cord swelling showed a trend toward complete injury at presentation. Patients managed operatively were observed to have significant improvement in stenosis. In patients with stenosis at the time of admission, neurological deficit was present in 14 patients. Neurological improvement was noted in 12 patients (85.7%), and no improvement was noted in 2 patients (14.3%). In patients with altered marrow signal at the time of admission, 20 patients had neurological deficit. Neurological improvement was noted in 17 patients (85%), and no improvement was noted in 3 patients (15%) Radiograph, computed tomography (CT), and magnetic resonance imaging (MRI) features at the time of initial presentation [Figure 3a] and at one year follow up [Figure 3b] in a 65-year-old female.

Table 3: CT scan parameters from the time of presentation to subsequent follow-ups

Canal measurements	Initial	1-year
Canal dimensions (AP)	9.64±3.35	13.61±1.61
Canal dimensions (transverse)	16.49±6.61	15.02±4.40
Compression percentage	42±0.24%	28±0.24%
Beck index	0.632±0.32	0.50±0.29

CT – Computed tomography; AP – Anterior-posterior

Discussion

The use of MRI is now well established as the method of choice in examining patients with SCI, and correlating it with their neurological status and using it as a possible predictor of neurological recovery.^[13-16] Although CT scan is superior

Table 4: CT and MRI parameters in operative and nonoperative patients

	Initial		3 months		6 months		1-year	
	Operative (n=16)	Nonoperative (n=9)	Operative (n=16)	Nonoperative (n=9)	Operative (n=16)	Nonoperative (n=9)	Operative (n=16)	Nonoperative (n=9)
CT								
Canal dimensions (AP)	8.71±3.21	11.30±3.08						
Canal dimensions (transverse)	14.56±5.15	19.90±7.80						
Beck index	0.56±0.17	0.74±0.49						
MRI								
Quantitative findings								
MSCC (%)	41±0.32	22±0.29	19±0.17	18±0.27	14±0.14	16±0.26	9±0.23	14±0.21
MCC (%)	67±0.23	30±0.25	36±0.21	21±0.24	28±0.17	16±0.21	22±0.17	14±0.21
Lesion length (mm)	17.20±25.78	37.44±33.95	13.05±21.89	25.65±24.04	10.77±19.58	17.06±29.36	7.77±33.85	11.14±12.54
Qualitative findings								
Edema	6	6	5	6	2	6	1	6
Hemorrhage	4	0	4	0	4	0	4	0
Cord swelling	2	1	2	1	2	1	2	1
Stenosis	14	1	3	1	3	1	3	1

CT – Computed tomography; AP – Anterior-posterior; MRI – Magnetic resonance imaging; MSCC – Maximum spinal cord compression; MCC – Maximum canal compromise

Table 5: Initial neurological status in terms of complete and incomplete injury with imaging parameters on radiographs, CT, and MRI

Parameters	Severity of the initial injury		
	Complete SCI (ASIA grade A) (n=8)	Incomplete SCI (ASIA grade B, C, D) (n=13)	No deficit (ASIA grade E) (n=4)
Plain radiographs			
Sagittal index	6.89±3.18	9.15±4.65	7.25±1.5
Gardner's kyphotic deformity	14.63±2.26	16.61±5.20	14.75±2.05
Regional kyphosis	15.63±1.41	16.85±3.18	16.75±1.89
CT			
Canal dimensions (AP)	10.67±2.72	8.57±2.93	11.07±5.28
Canal dimensions (transverse)	15.7±5.48	16.37±7.01	18.49±8.75
Beck index	0.61±0.17	0.55±0.13	0.95±0.73
Compression percentage	47±0.15	45±0.18	21±0.49
MRI			
MSCC	41±0.28	38±0.35	6±0.04
MCC	58±0.29	52±0.30	41±0.36
Lesion length	41.72±36.50	17.24±24.12	13.58±27.15
Edema	3	8	1
Hemorrhage	3	1	0
Cord swelling	2	1	0
Stenosis	5	9	1
Altered marrow signal	8	12	4
Posterior element fracture	1	4	2
Posterior ligamentous complex injury	5	9	1
Luxation	7	11	2

CT – Computed tomography; AP – Anterior-posterior; MRI – Magnetic resonance imaging; MSCC – Maximum spinal cord compression; MCC – Maximum canal compromise; SCI – Spinal cord injury; ASIA – American spinal injury association

in detecting precise bony injuries, MRI is the most sensitive modality for detecting spinal cord damage, disc protrusions and paraspinal soft tissue injuries.^[13,14] The diagnosis of the initial injury is critical in order to predict an accurate functional prognosis. The best time for prognostic imaging appears to be within the first 24–72 h of the injury and 2–3 weeks later.^[14,15]

Among KD, average correction of 3.32° (40.9%) in SI, 3.2° (20.4%) for Gardner's index and 3.44° (21%) for regional kyphosis was observed at 3 months follow-up. Patients with SI >10, Gardner's index >20 and regional kyphosis >10 were observed to have incomplete SCI, but correlation was not statistically significant ($P = 0.624$). In the present study, correction in the KD was achieved on subsequent follow-ups, but it did not correlate initially and on subsequent follow-ups with neurological recovery. The improvement in average canal dimensions (AP) was statistically significant

Table 6: Quantitative and qualitative parameters on MRI

MRI findings	Initial	3 months	6 months	1-year
Quantitative findings				
MSCC	34±0.31	19±0.21	15±0.19	11±0.15
MCC	54±0.3	30±0.23	24±0.19	19±0.19
Lesion length	25.25±29.55	18.15±22.75	13.34±18.44	9.21±13.63
Qualitative parameter				
Edema	12	11	8	7
Hemorrhage	4	4	4	4
Cord swelling	3	3	3	3
STI	15	15	14	14
Stenosis	15	4	4	4
Disc herniation	20	8	5	5
Epidural hematoma	0	0	0	0
Body fracture	24	24	24	24
Altered marrow signal	24	22	20	20
Posterior element fracture	7	7	7	7
Posterior ligamentous complex injury	15	2	0	0
Prevertebral edema	12	11	6	3
Luxation	20	10	9	9
Spondylosis	0	0	0	0
Foreign body	0	0	0	0

MRI – Magnetic resonance imaging; MSCC – Maximum spinal cord compression; MCC – Maximum canal compromise; STI – Soft tissue injury

($P = 0.001$) at 1-year follow-up. Canal dimensions (AP) increased significantly on subsequent follow-ups, which was statistically significant in operatively treated patients ($P = 0.001$), but not in nonoperative patients ($P = 0.086$). We also observed improvement of canal diameter at 6 months follow-up and thereafter also, which indicated spontaneous canal remodeling continues with time, as also observed by various studies.^[17,18] There was no correlation between initial as well as of final canal compromise with neurological recovery. Similar observations were made by Hardons and Galloway.^[19] This indicates that bony canal dimension improvement alone does not guide to a favorable outcome; initial trauma to neural tissue and vitality of neural structures is of more significance. However, Yamazaki *et al.*^[20] analyzed the factors affecting outcome after traumatic central cord syndrome and used CT to assess the AP diameter of the spinal canal. They reported a relatively larger AP diameter of the canal to be predictive of greater neurological recovery. There was a significant correlation between CP and neurological status at presentation ($P < 0.001$). Similar results were shown by other studies.^[21-24]

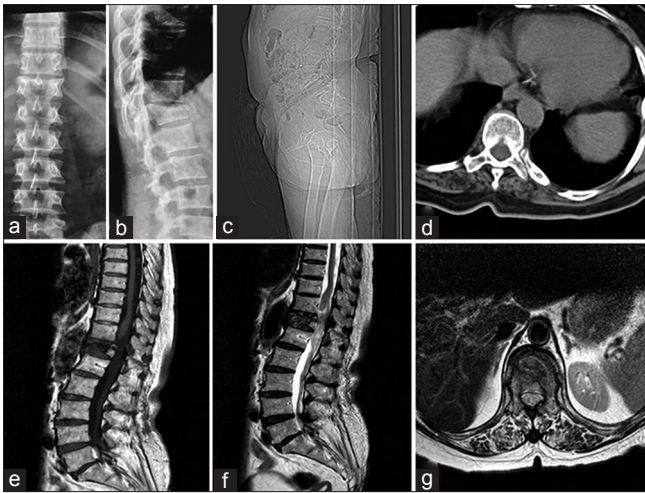

Figure 3b: A 65-year-old female had a road side accident 28 h prior to investigations. Clinical examination showed initial AIS Grade A. Radiograph, computed tomography (CT), and magnetic resonance imaging (MRI) features at 1-year follow-up. (a and b) Plain radiograph (anteroposterior and lateral views) shows wedging of the D12 vertebra. Radiological measurements showed the sagittal index, Gardner's index, and regional kyphosis values of 5°, 12°, and 11°, respectively. CT scan measurements showed canal dimensions, compression percentage, and Beck index values of 16.7, 4%, and 0.45, respectively. (c and d) MRI sagittal T1-weighted (e) sagittal T2-weighted (f) and axial T2-weighted (g) images show maximum spinal cord compression, maximum canal compromise, and lesion length values of 4%, 10%, and 44.12 mm respectively. Patient improved to AIS D with resolution of qualitative parameters and improvement in quantitative parameters

Most studies in the literature had evaluated the qualitative parameters to assess the association between imaging parameters and neurological outcome in SCI^[13-16,25-30] and only a few studies had evaluated the quantitative parameters (degree of spinal canal compromise, cord compression and length of lesion).^[16,28-33] Kang *et al.*^[31] attempted to quantify canal compromise using lateral cervical radiographs. Hayashi *et al.*^[32] quantified cord compression at the level of maximum compression using MRI and dividing it into mild (cord diameter of more than two-thirds) and severe cord compression (cord diameter of <2/3). The present study used an objective method, which has previously been approved to be reliable, standardized and objective, to quantify MR images obtained from patients with SCI.^[12,27]

The quantitative measurements of MSCC and MCC used in our study have been previously reported to be objective, reliable and standardized with good inter- and intra-observer reliability.^[33,34] Miyanji *et al.*^[16] reported that patients with complete motor and sensory SCIs had more substantial MCC ($P = 0.005$), MSCC ($P = 0.002$), and lesion length ($P = 0.005$) than did patients with incomplete SCIs and those with no SCI. MCC ($P = 0.012$), MSCC ($P = 0.014$) correlated with baseline ASIA motor scores. In a study by Chandra *et al.*,^[30] degree of cord compression had an important bearing on the severity of cord injury and degree of cord compression was proposed

as important outcome measures linked to prognosis. Similarly, Haar *et al.*^[28] also reported that patients with complete SCI had a more substantial MSCC ($P = 0.008$), MCC ($P = 0.009$) and lesion length ($P = 0.001$) compared to the other two groups (one with incomplete SCI and other without any neurological deficit). The length of the lesion ($P = 0.019$) correlated with baseline neurology. MSCC ($P = 0.063$), length of lesion ($P = 0.011$) and intramedullary hemorrhage ($P = 0.036$) were predictive of a poor neurological outcome. Similarly in our study there was a significant difference in all three parameters assessed among patients with a complete SCI, those with incomplete SCI and neurologically healthy patients. Patients with complete injury had significantly more CP ($P < 0.001$), MSCC ($P < 0.001$), MCC ($P < 0.001$) in comparison to incomplete injury as well as in comparison to neurologically healthy patients (compression percentage [$P < 0.001$], MSCC [$P < 0.001$], MCC [$P < 0.001$]). Patients with incomplete injury had significantly more CP ($P < 0.001$), MSCC ($P < 0.001$), MCC ($P < 0.001$) in comparison to neurologically healthy patients.

Several authors have described the most common MRI patterns of the cord following SCI.^[14-16,26,30-38] In a study by Miyanji *et al.*^[16] patients with complete SCIs also had higher frequencies of hemorrhage ($P < 0.001$), edema ($P < 0.001$), cord swelling ($P = 0.001$), stenosis ($P = 0.01$), and STI ($P = 0.001$). Cord swelling ($P < 0.001$) correlated with baseline ASIA motor scores. Hemorrhage ($P < 0.001$), and cord swelling ($P = 0.029$) were predictive of the neurologic outcome at follow-up. Hemorrhage ($P < 0.001$) and cord swelling ($P = 0.002$) correlated significantly with follow-up ASIA score after controlling for the baseline neurologic assessment. Similar to this in a study by Haar *et al.*^[28] patients with a complete motor and sensory SCI (Frankel A) had higher frequencies of intramedullary hemorrhage ($P < 0.001$), cord swelling ($P = 0.002$) and cord edema ($P < 0.001$) compared to the incomplete SCI (Frankel Grade B, C and D) and those without any neurology (Frankel Grade E). Intramedullary hemorrhage ($P = 0.001$) correlate with baseline neurology.

Although the cord is subjected to secondary insults following the initial trauma, it is generally accepted that the extent of cord damage is mainly caused by the amount of force at the initial impact.^[35,36] Although the cord is fairly resistant to direct physical (structural) disruption, a very minor injury can cause significant cord malfunction.^[28] Kulkarni *et al.*^[25] observed that patients with intraspinal hemorrhage had an insignificant recovery; however, patients with cord edema recovered significantly. Schaefer *et al.*^[13] reported that patients with intramedullary hemorrhage were found to have a complete motor loss; patients with edema had a lesser degree of neurological degree. In a study by Bondurant *et al.*^[14] three patterns were observed; patients with hemorrhage had no improvement, patients with edema showed improved recovery and patients with both edema

and hemorrhage showed recovery intermediate between above two groups. Flanders *et al.*^[26] found that all patients with a neurological deficit had abnormal spinal cords at MRI; intramedullary hemorrhage was predictive of a complete lesion and patients with residual cord compression following reduction demonstrated greater neurological compromise than those without compression. Marciello *et al.*^[37] reported that all patients with spinal cord hemorrhage on their initial MRI had complete motor injuries and had little change in their motor scores with time whereas patients without hemorrhage had a much better prognosis. In a study by Shimada and Tokioka,^[15] patients with hemorrhage were reported to have a poor prognosis. In a study by Parashari *et al.*,^[29] patients with presence of sizable focus of hemorrhage had larger cord edema and more severe grade of initial AIS than those without hemorrhage with significantly more chances of retaining complete injury at follow-up. Patients with a small amount of hemorrhage (<1 cm) showed relatively better outcome. Patients with hemorrhage had significantly lower upper extremity motor scores at the time of injury and follow-up. There was a definitive correlation of length of cord edema with sensory outcome, and recovery rates of sensory scores were significantly lower in patients with hemorrhage when compared with those without hemorrhage in the spinal cord. Severe cord compression was associated with poor neurological function at admission and discharge. In a study by Chandra *et al.*,^[30] patients with transient cord edema where the signal changes revert to normal on follow-up imaging had a better outcome; swelling of cord was associated with a worse initial neurological status and poor prognosis; presence of hemorrhage was associated with a poor neurological status on presentation and follow-up. Takahashi *et al.*^[38] reported that the degree of cord compression was correlated with recovery of neurological function. Findings of the present study also substantiated the findings of these studies, intramedullary hemorrhage correlated significantly with baseline neurological status. Cord edema neither correlated with baseline neurology nor as a predictor of outcome. Patients with cord swelling and stenosis showed a trend toward severe neurological deficit at presentation although it was not statistically significant ($P = 0.816$). There was a significant improvement with time in operative patients for edema ($P = 0.01$) and spinal cord stenosis ($P = 0.001$).

Conclusions

The present study concludes that imaging modalities in spinal cord injuries have a major role in diagnosis, directing management and predicting prognosis. Radiographs are useful to predict the severity of KD, which serve as useful guide to the severity of injury and neurological status. Narrower canal dimensions and high compression of the affected vertebrae measured on CT are correlated significantly to initial neurological status. Quantitative and qualitative parameters

measured on MRI have a significant role for predicting initial severity of neurological status and outcome. Among qualitative parameters hemorrhage, cord swelling and stenosis are particularly useful guides to predict the severity of neurological injury. Although operative intervention helps in improving canal dimensions, Beck index and spinal cord compression but it may not improve ultimate neurological outcome. Patients with initial complete injury have significantly more initial KD; canal and cord compromise; Beck index; CP; MSCC; MCC; and lesion length. Neurological recovery is less in these patients. MRI is an excellent modality to evaluate acute SCI, and MR images obtained in the acute period significantly and usefully predict neurological outcome.

References

1. Nobunaga AI, Go BK, Karunas RB. Recent demographic and injury trends in people served by the Model Spinal Cord Injury Care Systems. *Arch Phys Med Rehabil* 1999;80:1372-82.
2. Tony G, Tyrrell P. Magnetic resonance imaging of spinal trauma. *RAD Magazine*, 37, 438, 15-16.
3. Daffner RH. Cervical radiography for trauma patients: A time-effective technique? *AJR Am J Roentgenol* 2000;175:1309-11.
4. Daffner RH. Helical CT of the cervical spine for trauma patients: A time study. *AJR Am J Roentgenol* 2001;177:677-9.
5. Brandt MM, Wahl WL, Yeom K, Kazerooni E, Wang SC. Computed tomographic scanning reduces cost and time of complete spine evaluation. *J Trauma* 2004;56:1022-6.
6. Flanders AE, Croul SE. Spinal trauma. In: Atlas SW, editor. *Magnetic Resonance Imaging of the Brain and Spine*. 3rd ed. Philadelphia: Lippincott, Williams, and Wilkins; 2002. p. 1769-824.
7. Bagley LJ. MR of spinal trauma. In: Taveras JM, Ferrucci JT, editors. *Radiology: diagnosis, Imaging, Intervention*. Philadelphia: Lippincott, Williams, and Wilkins; 2002. p. 1-10.
8. Tator CH. Biology of neurological recovery and functional restoration after spinal cord injury. *Neurosurgery* 1998;42:696-707.
9. Kirshblum SC, Burns SP, Biering-Sorensen F, Donovan W, Graves DE, Jha A, *et al.* International standards for neurological classification of spinal cord injury (revised 2011). *J Spinal Cord Med* 2011;34:535-46.
10. Chafetz RS, Vogel LC, Betz RR, Gaughan JP, Mulcahey MJ. International standards for neurological classification of spinal cord injury: Training effect on accurate classification. *J Spinal Cord Med* 2008;31:538-42.
11. Farcy JP, Weidenbaum M, Glassman SD. Sagittal index in management of thoracolumbar burst fractures. *Spine (Phila Pa 1976)* 1990;15:958-65.
12. Fehlings MG, Rao SC, Tator CH, Skaf G, Arnold P, Benzel E, *et al.* The optimal radiologic method for assessing spinal canal compromise and cord compression in patients with cervical spinal cord injury. Part II: Results of a multicenter study. *Spine (Phila Pa 1976)* 1999;24:605-13.
13. Schaefer DM, Flanders A, Northrup BE, Doan HT, Osterholm JL. Magnetic resonance imaging of acute cervical spine trauma. Correlation with severity of neurologic injury. *Spine (Phila Pa 1976)* 1989;14:1090-5.
14. Bondurant FJ, Cotler HB, Kulkarni MV, McArdle CB, Harris JH Jr. Acute spinal cord injury. A study using physical examination and magnetic resonance imaging. *Spine (Phila Pa 1976)* 1990;15:161-8.
15. Shimada K, Tokioka T. Sequential MR studies of cervical cord injury: correlation with neurological damage and clinical outcome. *Spinal Cord* 1999;37:410-5.
16. Miyajiri F, Furlan JC, Aarabi B, Arnold PM, Fehlings MG. Acute cervical traumatic spinal cord injury: MR imaging findings correlated with neurologic outcome – prospective study with 100 consecutive patients. *Radiology* 2007;243:820-7.
17. Leferinck VJ, Nijboer JM, Zimmerman KW, Veldhuis EF, ten Vergert EM, ten Duis HJ. Burst fractures of the thoracolumbar spine: Changes

- of the spinal canal during operative treatment and follow-up. *Eur Spine J* 2003;12:255-60.
18. Dai LY. Remodeling of the spinal canal after thoracolumbar burst fractures. *Clin Orthop Relat Res* 2001;382:119-23.
 19. Herndon WA, Galloway D. Neurologic return versus cross-sectional canal area in incomplete thoracolumbar spinal cord injuries. *J Trauma* 1988;28:680-3.
 20. Yamazaki T, Yanaka K, Fujita K, Kamezaki T, Uemura K, Nose T. Traumatic central cord syndrome: Analysis of factors affecting the outcome. *Surg Neurol* 2005;63:95-9.
 21. Liu S, Li H, Liang C, Long H, Yu B, Chen B, *et al.* Monosegmental transpedicular fixation for selected patients with thoracolumbar burst fractures. *J Spinal Disord Tech* 2009;22:38-44.
 22. Yue JJ, Sossan A, Selgrath C, Deutsch LS, Wilkens K, Testaiuti M, *et al.* The treatment of unstable thoracic spine fractures with transpedicular screw instrumentation: A 3-year consecutive series. *Spine (Phila Pa 1976)* 2002;27:2782-7.
 23. Shin TS, Kim HW, Park KS, Kim JM, Jung CK. Short-segment pedicle instrumentation of thoracolumbar burst-compression fractures; short term follow-up results. *J Korean Neurosurg Soc* 2007;42:265-70.
 24. Defino HL, Canto FR. Low thoracic and lumbar burst fractures: Radiographic and functional outcomes. *Eur Spine J* 2007;16:1934-43.
 25. Kulkarni MV, McArdle CB, Kopanicky D, Miner M, Cotler HB, Lee KF, *et al.* Acute spinal cord injury: MR imaging at 1.5 T. *Radiology* 1987;164:837-43.
 26. Flanders AE, Schaefer DM, Doan HT, Mishkin MM, Gonzalez CF, Northrup BE. Acute cervical spine trauma: Correlation of MR imaging findings with degree of neurologic deficit. *Radiology* 1990;177:25-33.
 27. Rao KV, Saradhi MV, Purohit AK. Factors affecting long-term outcome in acute cervical cord injury. *Indian J Neurotrauma* 2010;7:149-56.
 28. Haar MT, Naidoo SM, Govender S, Parag P, Esterhuizen TM. Acute traumatic cervical spinal cord injuries: Correlating MRI findings with neurological outcome. *S Afr Orthop J* 2011;10:35-41.
 29. Parashari UC, Khanduri S, Bhadury S, Kohli N, Parihar A, Singh R, *et al.* Diagnostic and prognostic role of MRI in spinal trauma, its comparison and correlation with clinical profile and neurological outcome, according to ASIA impairment scale. *J Craniovertebr Junction Spine* 2011;2:17-26.
 30. Chandra J, Sheerin F, Lopez de Heredia L, Meagher T, King D, Belci M, *et al.* MRI in acute and subacute post-traumatic spinal cord injury: Pictorial review. *Spinal Cord* 2012;50:2-7.
 31. Kang JD, Figgie MP, Bohlman HH. Sagittal measurements of the cervical spine in subaxial fractures and dislocations. An analysis of two hundred and eighty-eight patients with and without neurological deficits. *J Bone Joint Surg Am* 1994;76:1617-28.
 32. Hayashi K, Yone K, Ito H, Yanase M, Sakou T. MRI findings in patients with a cervical spinal cord injury who do not show radiographic evidence of a fracture or dislocation. *Paraplegia* 1995;33:212-5.
 33. Fehlings MG, Furlan JC, Massicotte EM, Arnold P, Aarabi B, Harrop J, *et al.* Interobserver and intraobserver reliability of maximum canal compromise and spinal cord compression for evaluation of acute traumatic cervical spinal cord injury. *Spine (Phila Pa 1976)* 2006;31:1719-25.
 34. Chakeres DW, Flickinger F, Bresnahan JC, Beattie MS, Weiss KL, Miller C, *et al.* MR imaging of acute spinal cord trauma. *AJNR Am J Neuroradiol* 1987;8:5-10.
 35. Ikata T, Iwasa K, Morimoto K, Tonai T, Taoka Y. Clinical considerations and biochemical basis of prognosis of cervical spinal cord injury. *Spine (Phila Pa 1976)* 1989;14:1096-101.
 36. Walker MD. Acute spinal-cord injury. *N Engl J Med* 1991;324:1885-7.
 37. Marciello MA, Flanders AE, Herbison GJ, Schaefer DM, Friedman DP, Lane JJ. Magnetic resonance imaging related to neurologic outcome in cervical spinal cord injury. *Arch Phys Med Rehabil* 1993;74:940-6.
 38. Takahashi M, Izunaga H, Sato R, Shinzato J, Korogi Y, Yamashita Y, *et al.* Correlation of sequential MR imaging of the injured spinal cord with prognosis. *Radiat Med* 1993;11:127-38.

How to cite this article: Singh R, Kumar RR, Setia N, Magu S. A prospective study of neurological outcome in relation to findings of imaging modalities in acute spinal cord injury. *Asian J Neurosurg* 2015;10:181-9.

Source of Support: Nil, **Conflict of Interest:** None declared.