

## Review

# From Nobeyama Radio Observatory to the international project ALMA —Evolution of millimeter and submillimeter wave astronomy in Japan—

By Masato ISHIGURO,<sup>\*1,†</sup> Kurazo CHIBA<sup>\*2</sup> and Seiichi SAKAMOTO<sup>\*1</sup>

(Edited by Masanori IYE, M.J.A.)

**Abstract:** The establishment of the Nobeyama Radio Observatory (NRO) in 1982 was an important event that greatly influenced the subsequent development of Japanese astronomy. The 45 m radio telescope and the Nobeyama Millimeter Array (NMA) pushed Japanese radio astronomy to the forefront of the world. As a plan beyond the Nobeyama telescopes, the Japanese radio astronomy community considered a large array to achieve unprecedented resolution at millimeter and submillimeter wavelengths under the project name of the Large Millimeter and Submillimeter Array (LMSA). After long and patient discussions and negotiations with the United States and Europe, the LMSA plan eventually led to the ALMA (Atacama Large Millimeter/submillimeter Array) as an international joint project, and the ALMA was inaugurated in 2013. This paper reviews the process from the establishment of the NRO to the realization of the ALMA, including planning of the LMSA, international negotiations, site survey, instrumental developments, and initial science results.

**Keywords:** radio astronomy, millimeter, submillimeter, telescope, interferometer, ALMA

## 1. Introduction

Radio astronomy in Japan began in the late 1940s. Despite the difficult social situation after World War II, the rise of radio astronomy in Japan was not that late compared to other countries. There was an overwhelming shortage of parts to make radio telescopes, but scientists at that time were able to start observing solar radio waves using second-hand military radar antennas and receivers.<sup>1)</sup>

Koichi Shimoda made a radio telescope with a parabolic reflector of 2 m diameter and observed the variation of radio waves at 3 GHz due to the solar eclipse on May 9, 1948, which became the first radio astronomy observation in Japan.<sup>2)</sup> Following the observation of the solar radio waves by Shimoda, Minoru Oda's group at Osaka University started continuous observation of the Sun at 3.3 GHz using

an electromagnetic horn.<sup>3)</sup> In 1950, Oda's Group proposed the concept of a radio interferometer with an array of horn antennas, a total of 25 antennas arranged in a grid pattern, but it was never actually constructed.<sup>4)</sup> However, this was the first concept of a radio interferometer in Japan.

In March 1953, enlightened by the Oda Group's concept, Haruo Tanaka and Takakiyo Kakinuma built a radio interferometer of five 1.5 m-diameter parabolic reflectors working at 4 GHz at the Research Institute of Atmospheric Physics of Nagoya University in Toyokawa.<sup>5)</sup> This was the first radio interferometer built in Japan, and it is noteworthy that it was completed only one year after the first one was built in the world, a 32-element 1.42 GHz radio interferometer<sup>6)</sup> constructed in Australia by Wilbur Christiansen in February 1952. The radio interferometers at Toyokawa evolved into two-dimensional arrays (radio heliographs) with 48 and 49 elements at the wavelengths of 3 cm<sup>7)</sup> and 8 cm,<sup>8)</sup> respectively. The accumulation of technologies on solar radio interferometry was finally inherited by the Nobeyama Radioheliograph.<sup>9)</sup>

In the field of cosmic radio astronomy, Japan's first millimeter-wave telescope with 6 m diameter<sup>10)</sup>

<sup>\*1</sup> National Astronomical Observatory of Japan, Mitaka, Tokyo, Japan.

<sup>\*2</sup> School of Environment and Society, Tokyo Institute of Technology, Tokyo, Japan.

<sup>†</sup> Correspondence should be addressed to: M. Ishiguro, National Astronomical Observatory of Japan, Osawa 2-21-1, Mitaka, Tokyo 181-8588, Japan (e-mail: masato.ishiguro@nao.ac.jp).

was constructed in 1970 at the Tokyo Astronomical Observatory (TAO) of the University of Tokyo, and it became a major driving force for establishing the Nobeyama Radio Observatory (NRO) and constructing the 45 m radio telescope<sup>11)</sup> and the Nobeyama Millimeter Array (NMA).<sup>12)</sup> The observatory became the first nationwide common-use facility in Japanese astronomy and greatly contributed to the development of the radio astronomy community in Japan.

Immediately after the completion of the radio telescopes at the NRO, the study of the next generation plan began in 1983, led by scientists at the NRO. It was agreed to promote the Large Millimeter and Submillimeter Array (LMSA) project aiming capabilities at submillimeter wavelengths with longer baselines (higher angular resolution) which were not possible at the Nobeyama site. At that time, there were plans similar to the LMSA called the Millimeter Array (MMA) in the United States and the Large Southern Array (LSA) in Europe, and as a result of long-term negotiations on cooperation between these three plans, the three partners had agreed to unify the projects into a single international joint project called the Atacama Large Millimeter/submillimeter Array (ALMA), the world's largest astronomical observation facility constructed at an altitude of 5000 m in northern Chile.

In this paper, we give an overview of how Japanese millimeter-wave and submillimeter-wave astronomy evolved from the NRO to the ALMA, summarizing the promotion of the LMSA project as a next step of the NRO and the unification of the three independent projects into the ALMA, with its associated instrumental developments, site survey activities, and initial science results. The descriptions of instruments and science results are mainly limited to the status before the ALMA inauguration in 2013.

## 2. The 6 m millimeter wave telescope and the onset of millimeter wave astronomy in Japan

After World War II, radio astronomy was started by British and Australian scientists who had been studying radar technology during the war. In the 1960s, single-dish radio telescopes of up to 76 m diameter were constructed in the United States, Europe, Australia, and other countries. Using those radio telescopes, many important discoveries continued such as quasars, cosmic background radiation, and interstellar molecules. Those results could only be achieved by radio observations instead of optical

observations, which had been the mainstream until then. In this era, a new direction was born by pioneering millimeter-wave observations. In 1970, using the NRAO (National Radio Astronomy Observatory) 36 ft millimeter wave telescope in the United States, Robert Wilson *et al.* discovered the interstellar molecular spectral line of CO<sup>13)</sup> which provided a standard tool to investigate the structure and dynamics of molecular clouds such as in star-forming regions and galaxies and strongly determined the direction of subsequent development in millimeter wave astronomy.

Inspired by the gold rush of discoveries of interstellar molecules, the radio astronomy group led by Kenji Akabane and Masaki Morimoto at TAO built a 6 m millimeter wave telescope in 1970, the same year of the discovery of CO (Fig. 1). This was the onset of millimeter wave astronomy in Japan. The spectrometer is a key item in a millimeter wave telescope. An analog filter bank type spectrometer was used initially which was later replaced by an acousto-optic radio spectrometer (AOS). The AOS incorporated the idea used in solar radio observation at that time and proved to be very effective. Their achievements, such as the detection of the interstellar methylamine in the Orion Nebula, played a major role in promoting the project to construct large millimeter wave telescopes in Japan.



Fig. 1. 6 m millimeter wave telescope (Credit: NAOJ).

### 3. Establishment of the Nobeyama Radio Observatory

**3.1. Construction of the 45 m radio telescope and the Nobeyama Millimeter Array.** In the latter half of the 1960's, a deliberation of the "Large Radio Telescope Project" was initiated by the Astronomical Research Liaison Committee of the Science Council of Japan (SCJ) in order to bring Japan's radio astronomy to the world level. Three plans were examined:

Plan 1) 60 m radio telescope mainly for HI observations with 30 m radio telescope for shorter wavelengths;

Plan 2) 30 m radio telescope specialized in a performance at millimeter wavelengths;

Plan 3) 45 m radio telescope with two 20 m antennas to be used for interferometric mode.

As a result, in May 1970, the General Assembly of SCJ approved the establishment of the "Large Radio Telescope facility" and recommended it to the Prime Minister. After a series of discussions among the radio astronomy community in Japan, a plan was finalized to build a 45 m radio telescope and a millimeter array of five 10 m antennas to achieve the largest collecting area and the highest angular resolution in the world for millimeter astronomy.

Although there were some twists and turns before the construction started, Nobeyama was selected as the site because of its suitable conditions for observations at millimeter wavelengths. Construction was started in 1978 and completed in 1982, and the NRO, TAO of the University of Tokyo was inaugurated and started its open use observations.

The 45 m radio telescope was (and still is) one of the largest millimeter wave single dish telescopes in the world (Fig. 2). In order to enable millimeter wave observations, the accuracy of the antenna surface was specified to be less than 0.4 mm (rms), which was achieved by incorporating a method called "homologous deformation" into the structural design. In addition, the thermal deformation of the main reflector caused by solar irradiation was minimized by applying carbon fiber material to the reflector panels and covering the structure with heat insulating materials. The surface accuracy was measured by a laser ranging theodolite initially and a radio holographic method at the later stage and panel settings were adjusted with a sophisticated panel adjustment system and the surface accuracy of 0.2 mm (rms) was achieved (as of November 1983).



Fig. 2. (Color online) 45 m radio telescope (Credit: NAOJ).

Following the success of the acousto-optic radio spectrometer (AOS) developed for the 6 m millimeter wave telescope, a large-scale radio spectrometer with 32000 frequency channels (the world standard at that time was 500 channels) was developed for the 45 m radio telescope. Combining the powerful AOS with the large telescope aperture, the 45 m radio telescope has produced remarkable scientific results over a period of more than 30 years,<sup>14),15)</sup> including the discovery of many new interstellar organic molecules and the world's first observational evidence of a super massive black hole.<sup>16)</sup> It should be noted that the success of the black hole observation in detecting  $\pm 1000$  km clouds was due to AOS's ability to cover a wide bandwidth ( $250 \text{ MHz} \times 8$ ) that is not necessarily required for ordinary spectral observations.

Independently of the 45 m radio telescope, the NMA with 5 antennas of 10 m diameter and a maximum baseline length of 600 m was constructed for the purpose of observing with higher angular resolution (Fig. 3). The construction of the NMA was based on the experiences of many years of interferometer development at the Research Institute of Atmospherics of Nagoya University (Toyokawa, Aichi Prefecture). In 1984, the first aperture synthesis observation was made at 22 GHz with 3 configurations and the maximum baseline of 450 m, and the open use observations at 22 GHz started in 1986. In 1988, the first mm-wave observations were made at 115 GHz, and this frequency band was included in the open use. The NMA could achieve an angular resolution down to a few arcseconds at the best atmospheric condition and achieved high-resolution mapping of such as star forming regions and galaxies.<sup>17)</sup> However, the performance of the NMA



Fig. 3. (Color online) Nobeyama Millimeter Array (NMA)  
(Credit: NAOJ).

at short millimeter wavelengths was severely limited by the lower altitude of the Nobeyama site.

At the time of the completion of the NMA, there were only a few millimeter wave interferometers in the world, such as the interferometer with three 10 m antennas at the Owens Valley Radio Observatory (OVRO) of California Institute of Technology,<sup>18)</sup> the Berkeley Illinois Maryland Array (BIMA)<sup>19)</sup> with six 6 m antennas at University of California, Berkeley, and the interferometer of three 15 m antennas of IRAM (Institut de Radioastronomie Millimétrique: France, Germany, Spain).<sup>20)</sup> Due to the lack of experiences not only in aperture synthesis but also in millimeter wave interferometry in Japan, the construction of the NMA was quite a challenging task. Through the construction of an interferometer system consisting of high precision antennas, low noise and phase stable receiving system, and large digital correlator, the NMA contributed to the establishment of radio interferometry technology in Japan. Without the NMA it would have been very difficult for Japan to be a major partner of the ALMA project. With the construction of the NMA, a situation was created where Japan, the United States, and Europe competed with each other in millimeter wave interferometry, and laid the foundation for the subsequent ALMA project.

**3.2. The role of the Japan Radio Astronomy Forum.** At the time of planning (in the latter half of the 1960s) for the “Large Radio Telescope Facility”, the radio astronomy group at TAO, which played a central role in the planning, was an extremely small group of less than 10 people, and the “Large Radio Telescope Project” was too much for them to handle. In order to formulate the project plan and promote

its construction, a promoting organization of about 100 scientists and engineers was established under the name of the Japan Radio Astronomy Forum (JRAF) in December 1969, which was the first attempt in the field of astronomy in Japan.

Since the establishment of JRAF, a symposium has been held regularly at least once a year to discuss the science cases and the desirable telescope system to achieve scientific goals as well as the observatory operation and open use policies. The role of JRAF continued in the promotion of the LMSA/ALMA project. Learning from the success of the JRAF, Group of Optical and Infrared Astronomers (GOPIRA), an organization of scientists in optical and infrared astronomy, was established in 1980 and led the Subaru Telescope project to success.<sup>21)</sup>

#### 4. Large Millimeter and Submillimeter Array project in Japan

In 1983, the study of the next plan for radio astronomy in Japan started immediately after the completion of the NRO. Although it was thought too early to start the study of the next plan immediately after the completion of the new instrument, the Japanese radio astronomy community could carry out the study of the next plan with sufficient time. As a result, starting with the Large Millimeter Array (LMA), the project was developed into the LMSA incorporating the performance at submillimeter wavelengths, and further culminated into the international project ALMA.

**4.1. Large Millimeter Array project in the initial planning phase.** In 1983, the original plan of LMA was proposed as one of the future projects of the NRO. The plan was to build an array of up to thirty 10 m antennas by adding more 10 m antennas using the existing antenna pads of the NMA. In 1986, the plan was refined to a system of twenty 10 m antennas with extending the maximum baseline length to 2 km, aiming to achieve the world’s largest collecting area and highest resolution. It was a very ambitious plan incorporating a multi field-of-view capability using a focal plane array receiver at each antenna and a huge correlator system that is 400 times larger than the existing one. However, it seemed too challenging to extend the maximum baseline at the Nobeyama site, because of the difficulty in the atmospheric condition.

The study of the LMA was continued until the beginning of 1990’s. In the meantime, the discussion was carried out between the two options: 1) early realization at the Nobeyama site, and 2) aiming the

realization at the world's best site. The former argued that the NMA had the highest performance in the world at that time, and that the increase in the number of antennas should be realized as early as possible to keep the world leading status. In addition, a strong concern was indicated because of the difficulty in realizing the project at the best site outside Japan. The latter, on the other hand, assumed that the LMA budget would be difficult until the construction of Subaru Telescope ended (1999), and insisted that if it would take more than 10 years, it would be necessary to make the plan more attractive for at least 10 to 20 years. In order to quantitatively compare between the two options, it was agreed to investigate the availability of suitable sites outside Japan.

**4.2. LMSA project upgraded to incorporate submillimeter wave performances.** In 1991, it became clear that the LMA budget had to wait for the completion of the Subaru Telescope, and the plan was reexamined with a view looking 10 years from that time. Since then, discussions were made extensively at meetings organized by JRAF on the telescope design to meet the scientific requirements. At a meeting, it was emphasized that mapping observations of the fine structures of protoplanetary disks require an angular resolution down to 0.01 arcseconds and the submillimeter performance is crucial to achieve the requirement. In order to meet the requirement, the array should have 10 km size and should be located at an altitude higher than 4000 m. As it was very clear that those requirements could not be achieved at the Nobeyama site, the NRO had given high priority to finding the best site in the world.

Although the South Pole, the northern Indian mountains (Himalayas), and Qinghai Province, China were also considered as potential sites, the focus was on Maunakea, Hawaii, and northern Chile. In 1992, site survey in northern Chile was started under a collaboration with SEST (Swedish ESO<sup>1</sup> Submillimeter Telescope) and University of Chile. Twenty survey points were visited, and the temperature and the water vapor pressure were measured.<sup>22)</sup>

In October 1992, the International Astronomical Union Colloquium on "Astronomy with Millimeter and Submillimeter Wave Interferometry" was held in Hakone, Japan, and the Japanese plan "the LMA" was presented.<sup>22)</sup> Although the project name "the LMA" was used because of the consistency with the

previous name, it actually included capabilities at submillimeter wavelengths, and was essentially what we should call LMSA. The brief summary of instrumental parameters in the presentation was as follows:

- 50 antennas of 10 m diameter;
- Observing frequencies: from 35 to 500 GHz (possibly 650 and 800 GHz);
- Angular resolution: 0.1'' at  $\lambda$  1 mm;
- Baselines: 20 m–2 km;
- Potential sites: Maunakea in Hawaii and the Atacama Desert in northern Chile.

At this international conference, the MMA project of the United States<sup>23)</sup> and the LSA project of Europe<sup>24)</sup> were presented, and the meeting provided an opportunity to start discussions on possible international collaboration thereafter.

In 1994, the Committee on Astronomy of SCJ recommended the LMSA project as a top priority project for the future large-scale ground-based astronomy facility in Japan. In 1996, it was recognized that a resolution of 0.01 arcseconds was necessary to achieve 1 AU resolution for protoplanetary disks at a distance of 500 lyr, and this requirement was incorporated into the instrument specifications for the LMSA.

**4.3. Activities of submillimeter wave astronomy in Japanese universities.** In parallel with the study of the LMSA project led by the NRO, universities in Japan were working on their own submillimeter-wave astronomy. The Radio Astronomy Group of the University of Tokyo has developed a small 60 cm diameter automated millimeter-wave telescope and conducted the world's first survey of the entire galactic plane in the spectral line of CO molecules (wavelength: 1.3 mm) with the first telescope at Nobeyama in 1991 and the second telescope at Chile in 1994, revealing the temperature and density distribution of CO molecules over the entire galactic plane.<sup>25)</sup>

Another group of the University of Tokyo set up 1.2 m submillimeter telescope on the summit of Mount Fuji (3776 m altitude), aiming at the world's first full-scale observation of atomic carbon (CI) (Fig. 4). From 1998 to 2005, the group made wide-area observations of CI at wavelengths of 0.6 mm and 0.3 mm, and clarified the distribution of the CI region, which is apparently in the process of molecular cloud formation.<sup>26)</sup>

In 2004, the Radio Astronomy Group of Nagoya University converted the 4 m millimeter telescope "NANTEN" into a high precision submillimeter

<sup>1</sup> ESO: European Southern Observatory.



Fig. 4. (Color online) Mount Fuji Submillimeter-wave Telescope (Photo Courtesy: Yamamoto Group, Department of Physics, The University of Tokyo).



Fig. 5. (Color online) NANTEN2 (Credit: Nagoya University, Y. Fukui).

telescope “NANTEN2” and installed it in the Atacama Plateau (4800 m altitude) near the ALMA site in northern Chile (Fig. 5). The telescope has been used in studying the evolution of the interstellar medium by searching for molecular clouds in our galaxy and in the Large and Small Magellanic Clouds.<sup>27)</sup>

**4.4. Atacama Submillimeter Telescope Experiment as a pilot plan for LMSA.** It was noted that the Atacama site in northern Chile is extremely suitable for submillimeter wave observations. The

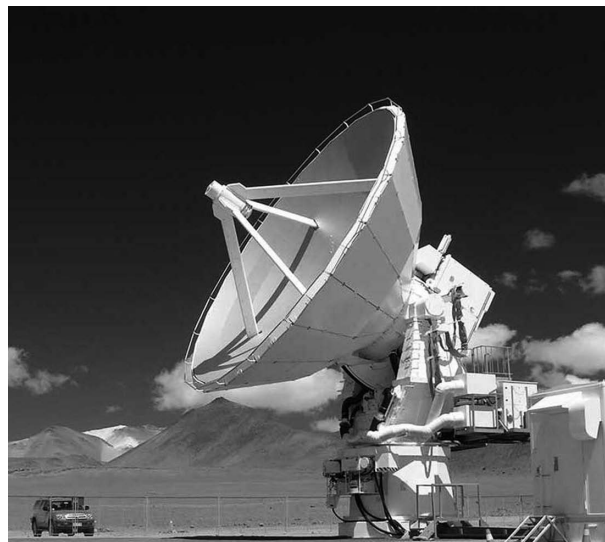

Fig. 6. (Color online) ASTE (Credit: NAOJ).

NRO, in collaboration with various Japanese universities, and the University of Chile, decided to proceed with submillimeter-wave observations at Pampa la Bola (4800 m altitude) on the Atacama Plateau. A newly built 10 m antenna was added to the NMA as the seventh element. This antenna was designed to have higher surface accuracy compared with the original antennas to enable observations at submillimeter wavelengths. After testing interferometric observations at Nobeyama, the antenna was relocated to the Atacama Plateau in 2002 to be used as a single dish submillimeter telescope and was named as ASTE (Atacama Submillimeter Telescope Experiment) (Fig. 6). Using ASTE, observations have been continued, focusing on submillimeter wavelengths (345 GHz $\sim$ ,  $\sim$ 0.7 mm wavelength).<sup>28),29)</sup>

## 5. ALMA: unification of the three projects in Japan, the United States, and Europe

At the International Astronomical Union Colloquium held in Hakone in 1992, project descriptions of the LMA (Japan), the MMA (the United States), and the LSA (Europe) were presented as well as the scientific results from existing millimeter and submillimeter interferometers.<sup>30)</sup> This section describes the original plans of Japan, the United States and Europe, and how they were merged into a single project ALMA (Figs. 7 and 8). Table 1 shows the history of the unification.

**5.1. Millimeter array project in the United States.** The concept of MMA was started in the early 1980s. Although NRAO was operating the

Table 1. History of the ALMA project

|         | East Asia (EA)  | North America (NA)  | Europe (EU)         |
|---------|---|---------------------|---------------------|
| 1983    | LMA (later LMSA) project plan   | MMA project plan    |                     |
| 1992.02 | Site survey in northern Chile started   |                     |                     |
| 10      | IAU Colloquium “Astronomy with Millimeter and Submillimeter Wave Interferometry”                                  |                     |                     |
| 1994.03 | The first official meeting on collaboration between LMSA and MMA  |                     |                     |
| 1995    |   |                     | LSA project plan    |
| 1997.03 | Workshop “Millimeter and Submillimeter Astronomy at 10 Milli-Arcseconds Resolution”                               |                     |                     |
| 1998.10 |   | R&D Budget          |                     |
| 12      |   |                     | R&D Budget          |
| 1999.06 | Cooperation for R&D between NA and EU   |                     |                     |
| 2001.04 | Resolution between ACC and NAOJ/MEXT towards the tripartite ALMA  |                     |                     |
| 11      |   | Construction Budget |                     |
| 2002.04 | R&D Budget  |                     |                     |
| 07      |   |                     | Construction Budget |
| 2003.02 | Construction of the Bilateral ALMA started  |                     |                     |
| 2004.04 | Construction Budget   |                     |                     |
| 09      | Construction of the Tripartite ALMA started<br>The project renamed “Atacama Large Millimeter/submillimeter Array” |                     |                     |
| 2013.03 | Inauguration and the full-fledged operations started  |                     |                     |

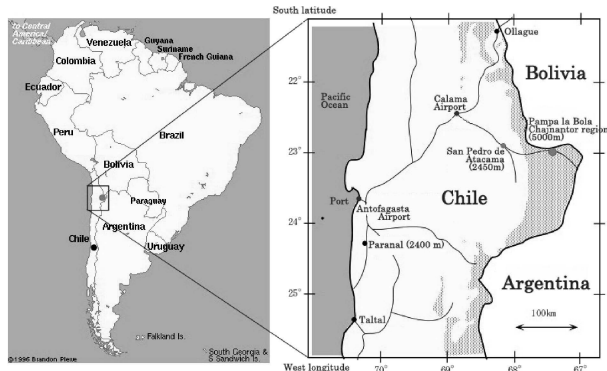

Fig. 7. (Color online) The ALMA construction site (Credit: NAOJ).

Kitt Peak 36 ft millimeter telescope at that time, interferometers at millimeter wavelengths, BIMA and OVRO, were developed and operated by university groups in California. It was natural for NRAO to plan a project to build a larger array at millimeter wavelengths with a large number of antennas and longer baselines compared with the university instruments. In 1990, the proposal to build



Fig. 8. (Color online) Aerial view of the central part of ALMA. Some of the empty pads for relocation are visible. Located in the center is the 7 m antennas of ACA. The building to the right is the Technical Building of the Array Operations Site. (Credit: Clem & Adri Bacri-Normier (wingsforscience.com)/ESO).

the MMA was submitted to NSF by Associated Universities, Inc. (AUI) as a next plan following the NRAO Very Large Array (VLA). The instrumental parameters proposed for the MMA were as follows<sup>II</sup>:

- 40 antennas of 8 m diameter;
- Observing frequencies: from 30 to 350 GHz;
- Sub-arcsecond imaging at 115 GHz and higher frequencies;
- Baselines: 70 m–3 km;
- Sites: two possible sites in the southwestern United States and Maunakea, Hawaii.

In 1991, the MMA project was positioned as the highest priority program for radio astronomy in the United States in the Decade Report (Bahcall Report)<sup>31)</sup> compiled by the National Research Council. At the IAU Colloquium held in 1992, Robert Brown, representing NRAO, reported that the construction could begin in 1997 or 1998 with pending approval of the NSF and the U.S. Congress.<sup>23)</sup>

### 5.2. Large Southern Array project in Europe.

In the 1980s, there was growing interest in millimeter-wave astronomy in Europe and telescopes for millimeter and submillimeter wavelengths were developed, such as the millimeter interferometer of three 15 m antennas at Plateau de Bure, France, the 30 m millimeter telescope at Pico Veleta, Spain, both operated by Institut de Radioastronomie Millimétrique (IRAM), the 15 m SEST in Chile, and the 15 m James Clerk Maxwell Telescope (JCMT) in Hawaii. At the IAU Colloquium held in 1992, Roy Booth, representing the European working group, reported about the LSA project. The first concept for a millimeter-wave interferometer in the southern hemisphere was proposed by Onsala Space Observatory in the late 1980s following the success of SEST. This was an array of ten 8 m antennas to be built near the ESO VLT (Very Large Telescope) site on Cerro Paranal, in northern Chile. At the end of 1991, after a long discussion in Europe, the LSA project was formulated with the aim of observing millimeter waves with a large collecting area. The discovery of redshifted CO in a galaxy at  $z \simeq 2.3$ <sup>32)</sup> had triggered the increase in the size of LSA to an unprecedented 10000 m<sup>2</sup> collecting area.

The instrumental parameters were as follows<sup>33)</sup>:

- 40 antennas of 15 m diameter (1991 proposal), 50 antennas of 16 m diameter (1995 proposal);
- Observing frequencies: up to 350 GHz;
- 0.1'' at 2.6 mm wavelength;
- Baselines: 10 km;
- Sites: northern Chile.

Since the maximum observation frequency of the LSA was 350 GHz, it did not require a higher altitude site such as that considered for the LMSA, and sites at a relatively low altitude of 3300 m and 3750 m were considered.

**5.3. History of negotiations between LMSA and MMA.** In March 1994, Paul Vanden Bout and Brown (NRAO's then Director and then Associate Director, respectively) visited National Astronomical Observatory of Japan (NAOJ) and met Keiichi Kodaira (NAOJ's then Director General) and the LMSA project members.<sup>34)</sup> A possible collaboration between the MMA and the LMSA was officially discussed for the first time. The most important message from the NRAO side was that NSF pointed out that major projects should be carried out through international collaboration. The NAOJ side reported the status of the LMSA project with a special emphasis on the report issued by the Subcommittee on Long Range Planning of the Astronomy Research Liaison Committee of SCJ in which the LMSA project was placed as the top priority plan for the future large-scale ground-based facility. Two models of collaboration were discussed. One is an integrated array of 64 antennas of 9 m diameter on Maunakea, Hawaii. The other is to install the MMA on Maunakea and the LMSA in Chile, to share the observations in the northern and southern hemispheres. Both NAOJ and NRAO recognized the importance of site selection and agreed to obtain and exchange data on site testing.

In June 1994, the URSI-IAU Millimeter-Submillimeter Array Working Group was held just before the IAU Symposium on the CO 25th Anniversary in Tucson. This working Group was proposed and coordinated by Masato Ishiguro and Booth at the Kyoto URSI General Assembly in 1993 and was reformed as an inter-union working group at the Hague IAU General Assembly in 1994. The representatives of SMA (Smithsonian Submillimeter Array) participated in the Tucson meeting and showed their interest in collaborating in site testing on Maunakea. On Maunakea, there was a large difference in atmospheric transparency between the summit (planned SMA site) and the lower VLBA (Very Long Baseline Array) site (planned MMA site). It was confirmed that site comparisons should be made including radio seeing between the summit, VLBA site, and northern Chile.

The NAOJ considered the LMSA to be located at the summit because of a submillimeter performance, however, the summit was too narrow to place

<sup>II</sup> "The Millimeter Array (National Radio Astronomy Observatory)", <https://www.nrao.edu/archives/files/original/fec9b645cbe35d2b0a1dd2c089274d16.pdf>.



the array extending in an area of a few km. Nonetheless, as the Maunakea site near the Subaru Telescope had an advantage in reducing the operating costs for NAOJ, it was quite reasonable for the NAOJ to consider Maunakea as the most promising candidate, unless Chile was to be considerably better than Maunakea. On the other hand, in the case of the MMA aiming the performance at millimeter wavelengths, the VLBA site was considered as the best site in securing the area to construct the MMA. It was agreed to extend further discussions when the results of the site testing data in Chile became available.<sup>35)</sup> Following the above discussions, an agreement was signed between NAOJ and NRAO in June 1995 to promote cooperative studies of potential astronomical sites for the LMSA/MMA.<sup>III</sup>

As it became clear that the Chilean site is superior to Maunakea, NRAO began to focus on the advantages of Chilean sites. Immediately following the MMA Science and Technical Workshop held in Tucson in October 1995, the MMA Advisory Committee (MAC) was held and recommended initial operation with a submillimeter band and outrigger stations to allow resolution significantly better than 0.1 arcseconds.<sup>36)</sup> In 1996, a new idea came up, that of combining the LMSA with the MMA at the same site in northern Chile in order to achieve 0.01 arcsec resolution which surpasses the Subaru Telescope and the Hubble Space Telescope (HST).

In 1997, the Japan–U.S. Joint Development Study on Submillimeter Wave Astronomy (1997–1999) between NAOJ and NRAO started under the support of the Japan Society for the Promotion of Science (JSPS) and the NSF International Division, and studies on science, sites, and technology development were conducted jointly. Under the above framework, the Japan–U.S. Workshop (Millimeter and Submillimeter Astronomy at 10 Milli-arcseconds Resolution) was held in Tokyo in March 1997. The array combining the LMSA with the MMA was named as “Atacama Array” and the importance of realizing a 10 km baseline at submillimeter wavelengths was emphasized at the workshop.<sup>37)</sup> The site in Chile considered was large enough to locate the MMA and the LMSA arrays about 10 km apart from each other and it was thought to be possible to operate as a combined-array mode occasionally to achieve a resolution of 10 milliseconds without a significant increase in cost.

**5.4. History of negotiations between LSA and MMA.** Riccardo Giacconi, ESO’s then Director General, considered that ESO should be involved in a large radio interferometer program in the form of international collaboration with NRAO. As the construction of the VLT (Very Large Telescope) in Paranal in northern Chile was completed in 1998, it was good timing for ESO to proceed with the next large astronomical facility. He recognized that the joint U.S.–Japan project might become a reality and feared that Europe would not be able to participate in it. In June 1997, the ESO Council encouraged ESO to continue appropriate research and preparatory work on the project with NRAO and NSF.<sup>38),39)</sup> In the same month, Giacconi and other representatives of ESO visited NRAO and a Memorandum of Understanding (MOU) was signed between ESO and NRAO towards a joint project in millimeter/submillimeter astronomy. The main goal was to work towards a joint project, funded by Europe and the United States in a 50/50 ratio, to build an array of 64 antennas of 12 m diameter in the highlands of Chile. It was also confirmed that negotiations would continue for Japan’s participation.<sup>38)</sup>

**5.5. Final negotiations towards the tripartite ALMA.** While the joint study based on the 1997 MOU between NRAO and ESO was underway, NAOJ participated in the work as an observer. In particular, the evaluation of the construction sites was conducted jointly by all three parties with a focus on two places in northern Chile at an altitude of around 5000 m.<sup>40)</sup>

The budget for Phase 1 (Design and Development research) was approved in the United States in October 1998 and in Europe in December 1998. In June 1999, NSF and European Coordinating Committee (ECC) signed an MOU on the merging of the MMA and the LSA under the project named ALMA (Atacama Large Millimeter Array). The MOU established the organizational structure of the ALMA, the top level of which is the ALMA Coordinating Committee (ACC), composed of 12 members, 6 members each from NSF and ECC.<sup>41)</sup> At that time, NAOJ could not commit to participate in the ALMA Project Phase 1 due to lack of budgetary support, and decided to participate in the project in an unofficial way, aiming for formal later participation. Therefore, it was agreed that appropriate coordination between the ALMA and the LMSA should continue until a formal trilateral MOU was negotiated and signed to merge the ALMA and the LMSA into one “Enhanced ALMA project”.

<sup>III</sup> <https://www.nrao.edu/archives/items/show/36716>.

A resolution between ACC and NAOJ/MESSC (the Ministry of Education, Science, Sport and Culture) on the coordination between the LMSA and the ALMA projects in the design and development phase was signed in November 1999, and the ALMA Liaison Group (ALG) was formed. The remit of ALG was to produce and evaluate options for Japanese contributions and to select the most scientifically and technically advantageous option(s) with the goal of defining the final Enhanced ALMA. The first ALG meeting was held at the IRAM office in Grenoble, and it was agreed that Ishiguro would serve as Chairperson and Brown as vice-Chairperson. The proposed possible areas of Japanese contribution in the Enhanced ALMA included additional antennas, SIS junction, SIS mixer for a selected frequency band, cryogenics, photonic LO, ultra-high-speed digital data transmission, and large-scale digital correlator. The face-to-face ALG meetings were held eight times between December 1999 and December 2001 with monthly teleconferences between the face-to-face meetings. The final proposal from ALG was compiled at the meeting held at NRAO (Charlottesville) in June 2000.

The enhancement plan proposed by NAOJ was reviewed by the ALMA Scientific Advisory Committee (ASAC) from a scientific point of view, and the priorities of the equipment to be realized were indicated. The ASAC was established in October 1999 to examine the ALMA system purely from a scientific point of view, setting aside as much as possible about political discussions. Japanese scientists have participated as an “active observer” since the first ASAC meeting and became an official member after October 2000.<sup>42)</sup> The enhancement items which ASAC set higher priority were as follows:

- Addition of new receiver bands (increase from 4 bands of Bilateral ALMA to 8 bands, especially submillimeter wave bands);
- Addition of ACA (Atacama Compact Array) (compact array of 12 small aperture antennas with 4 antennas of 12 m diameter);
- Adoption of high-performance correlator.

The trilateral arrangement of the Enhanced ALMA was discussed at the ACC meeting held in Paris in October 2000 and Director of the Research Institutes Division of MESSC was invited to address the ACC. He addressed that MESSC recognized the ALMA Project as one of the important projects in basic science to be promoted in Japan and would make best effort toward the successful start of the project in order that Japan could join the ALMA



Fig. 9. (Color online) Signing of the Trilateral Resolution for the joint construction of ALMA. Robert Eisenstein (NSF), Catherine Cesarsky (ESO), and Norio Kaifu (NAOJ), from left to right, signed the Trilateral Resolution for the joint construction of ALMA in 2001 (Credit: NAOJ).

project as a third equal partner. His statement was warmly welcomed by ACC. Since then, it was formally agreed that the ALMA project should be promoted in a trilateral framework by making the Japanese observers in various committees to be official members.<sup>43),IV</sup>

In April 2001 the ACC meeting was held in Tokyo and a new resolution towards the trilateral agreement was signed between the ACC and the NAOJ under the authority of the Ministry of Education, Culture, Sports, Science and Technology of Japan (MEXT) (Fig. 9).<sup>V</sup> After subsequent discussions in the ACC meeting held in Tokyo, the ACC decided to proceed with the unified project under the trilateral agreement between Europe, North America, and Japan.<sup>VI</sup> Starting with this, intensive discussions continued on specific proposals for Japan’s participation in the project, including a scientific scope, cost estimate, and division of tasks among the working-level officials and the negotiating team.

In the latter half of 2001, due to the severe economic situation in Japan, MEXT approved only the research and development budget for the next two years including a 12 m prototype antenna for the

<sup>IV</sup> One of the reasons why the U.S. and Europe took this statement seriously was that Japan had expressed its willingness to participate in the ALMA project to a European representative who met with a senior official of MESSC on a different matter in April 2000 (personal communications).

<sup>V</sup> In 2001, government ministries and agencies of Japan were reorganized and MESSC was changed to MEXT after merging of MESSC and STA (Science and Technology Agency).

<sup>VI</sup> <https://www.nrao.edu/archives/items/show/36713>.

ALMA. The MEXT also assumed that the construction budget would start in 2004, and the budget would not be able to share 1/3 of the Enhanced ALMA project. Considering this situation, ACC decided that it had no choice but to proceed with the bilateral project which would consist of 64 antennas of 12 m diameter and four receiving bands. The ACC also decided that the additional scope of the project, made possible by Japan's late participation, would be determined when the size of Japan's available resources became clearer.<sup>44)</sup>

The budget for the construction of the bilateral ALMA in the United States and Europe was approved in November 2001 and July 2002, respectively, and the construction began in June 2002 under a tentative organizational structure.

The Japan's participation plan was revised because it could not share 1/3, and the enhancement plan was changed as follows:

- ACA antennas: 12 antennas of 7 m diameter + 4 antennas of 12 m diameter;
- New receiver bands (Bands 4, 8, and 10);
- ACA Correlator;
- Common parts (such as computing and infrastructure).

In April 2004, the construction budget was approved by the Japanese government, and the construction of the tripartite ALMA was started (Fig. 10). A coordination meeting between the Joint ALMA observatory (JAO) and the NAOJ was held in London in July 2004 to decide the value of Japanese deliverables which determine the share of observing time. The value of Japanese deliverables was evaluated based on exactly the same criterion as those for the United States and Europe. The agreed share of the observing time was 33.75% (U.S.),

33.75% (Europe), 22.5% (Japan), 10% (Chile). In September 2004, a trilateral agreement was signed between ESO, NSF, and NINS (the National Institutes of Natural Sciences) and the official project name changed from the Atacama Large Millimeter Array to the Atacama Large Millimeter/sub-millimeter Array with keeping the acronym same as before.

A project "re-baselining" took place in 2005–2006 due to the increasing construction costs of the U.S. and European projects. The cost increase is due to several factors, such as the complexity of an international project, underestimated challenges of the site work, a significant increase in commodity prices, and a booming economy in Chile.<sup>45)</sup> As a result, the number of antennas to be manufactured by the United States and Europe was changed from 64 to 50. In addition, the U.S. and European share of the budget for infrastructure construction was increased. After re-calculating the value of deliverables based on the re-baselining, there was no change in the ratio of values to be delivered from each partner. After the participation of Canada, Taiwan and Korea, the ALMA partners were redefined as East Asia, North America, and Europe.

### 5.6. Relation with the host country Chile.

The site is granted in a concession to ALMA for 50 years in 2003 in exchanging for 10% of the observing time to the Chilean astronomy community. In addition, community relations have been considered as a key part of ALMA's presence in Chile. Since 2004, ALMA contributes through funds to the development of astronomy in Chile and the development of the Region of Antofagasta, where the ALMA is located. The Executives were requested to create a legal entity called "Radioastronomía Chajnantor Limitada (RCL)" to manage the land and associated annual rental fee. RCL was initially created by two of the Executives (AUI and ESO) in 2003, and NAOJ later joined as the third party in 2016.

Construction of the ALMA was done by the Executives. In order to manage the construction and operation of the ALMA in Chile, the JAO ("Joint ALMA Office" during the construction phase; "Joint ALMA Observatory" after completion) was established in 2004 by the ALMA Board.<sup>46)</sup> JAO is not a legal entity, and the Executives created their legal entities in Chile delegated by their legal representatives. The assets thus remain to be owned and managed by the Executives that delivered them. Similar collaborative relation with the Chilean government was also established for the other

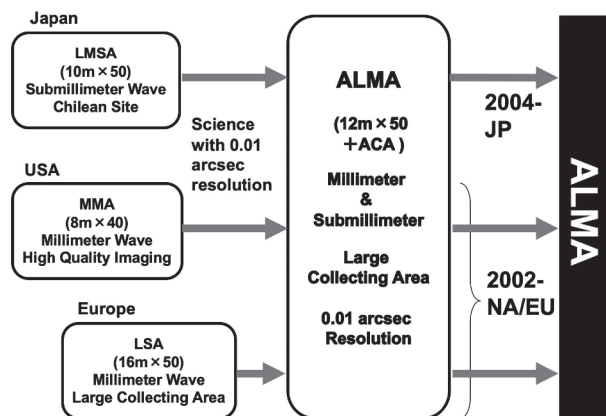

Fig. 10. The road to the tripartite ALMA.

Japanese projects in Chile, such as ASTE of NAOJ, NANTEN2 of Nagoya University, and the University of Tokyo Atacama Observatory (TAO).

### 5.7. Collaborations for ALMA in East Asia.

Cooperation in astronomical research in the East Asian region (Japan, China, Korea, and Taiwan) began in the 1990s. The East Asian Meeting of Astronomy (EAMA), a cooperative organization at the researcher level, was established and several international meetings were held. Following the EAMA activities, the East Asian Core Observatories Association (EACOA) was established in 2005 to promote a collaboration in astronomy in East Asia. The EACOA consisted of four core observatories in East Asia: National Astronomical Observatories of China (NAOC), NAOJ, Korea Astronomy and Space Science Institute (KASI), and Academia Sinica Institute of Astronomy and Astrophysics (ASIAA) was formed to foster and coordinate collaborations between the major astronomical observatories in the region.<sup>47)</sup>

In 2005, Taiwan joined the ALMA through Japan, and one of the three ALMA partners became ALMA East Asia (ALMA-EA). ASIAA in Taiwan fulfilled its responsibilities as one of the receiver integration centers in cooperation with a Taiwanese industry. The EA integration center performed really well and assisted both NA and EU integration centers. In addition to this, ASIAA made contributions such as participation in the Computing Group. It should be noted that many Japanese staff members have been involved in the SMA in Hawaii and the cooperation with ASIAA became a major backbone of ALMA-EA's activities. The collaboration on ALMA also led to collaborations on Subaru instrumentation for ASIAA, which has been really good for the joint development in optical wavelengths.

In 2012, Korea joined the ALMA-EA as a third member in East Asia and an agreement was signed between NAOJ and KASI. In 2010, the headquarters of the East Asian ALMA Regional Center (EA-ARC) was established at NAOJ to support scientists in the East Asian region as well as Japan in preparing observation proposals and analyzing data. Branches of ARC are located in ASIAA in Taiwan and KASI in Korea. ALMA East Asian Science Advisory Committee (EASAC) was established in 2006 to compile the opinions of scientists in the East Asian region and reflect them in the discussions at ASAC.

At one time, Chinese scientists had considered participating in the ALMA, but for various reasons this did not happen. However, the development of

SIS mixers for Band 8 and Band 10, which Japan was in charge of developing, was carried out with a collaboration with the Purple Mountain Observatory (PMO) in China. A researcher from the PMO stayed at NAOJ for a long period of time to conduct research and development and contributed to the development of the low-noise SIS mixer.

## 6. Site survey and site testing

**6.1. Selection criteria and identification of the best site in the world.** In general, the performance of a telescope depends not only on the instrumental performance but also on the quality of the installation site. For a large interferometer operating in millimeter and submillimeter wavelengths, the criteria considered for the site selection are as follows:

- (1) High atmospheric transmission at submillimeter wavelengths;
- (2) Good radio seeing to achieve sub-arc second imaging;
- (3) Flat and wide area (at least 3 km wide, possibly 10 km wide) to locate a large array;
- (4) Low wind velocity for accurate antenna pointing;
- (5) Good sky coverage;
- (6) Easy accessibility;
- (7) Existing infrastructure for minimizing the cost;
- (8) Safety and political stability of the host country.

In planning the LMSA project, as described in section 4.2, the South Pole, the northern Indian mountains (Himalayas), and Qinghai Province (China), Maunakea (Hawaii) and northern Chile were considered as potential site candidates. After a comparative study of these potential sites, based on statistical meteorological data and topographical information, the NAOJ set a focus on northern Chile. Although the NAOJ was interested in the sites in Asian countries because of their shorter distances from Japan compared with other candidates, it became clear that the accessibility to Indian and Chinese sites was not so good in reality. On the other hand, despite the great distance to Chile, the actual access proved to be very reliable, and the NAOJ decided to focus its site testing activities on Andean plateau in northern Chile.

**6.2. Site survey and site testing in northern Chile.** In 1992, the NAOJ started the first site survey activity for the LMSA project in northern Chile (Fig. 11) in collaboration with SEST group and University of Chile. The first visit was to Vega valley

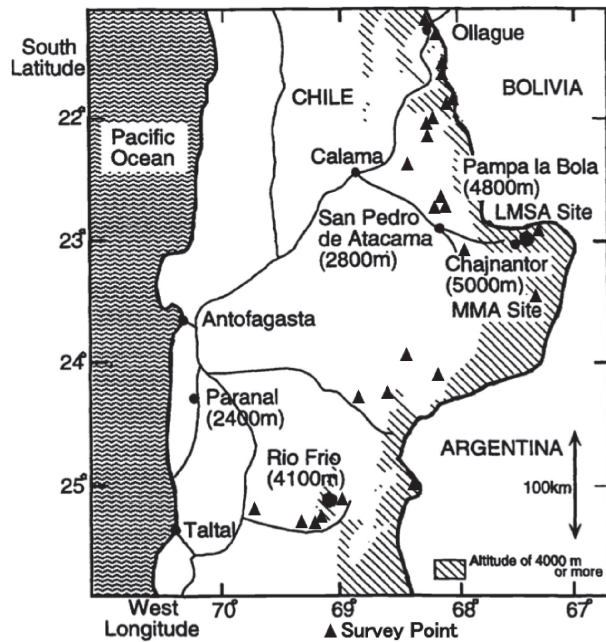

Fig. 11. Locations of the candidate LMSA sites in northern Chile. (The hatched area shows regions with altitude higher than 4000 m). The triangles indicate the places visited by the site survey team. The figure was redrawn based on Fig. 6 in Ref. 48.

(2400 m) and Cerro Armazones (3064 m) near the VLT site at Cerro Paranal. It became clear that the precipitable water vapor in these sites during southern summer is significantly lower than the typical values at Nobeyama during winter. In the same year, the NAOJ/SEST team visited about twenty of candidate sites in northern Chile spanning from  $-22.5^\circ$  to  $-25.5^\circ$  in latitude and from 2500 to 5000 m in altitude with handy weather equipment.<sup>48)</sup> Since 1995, the NAOJ team concentrated their activity to two selected areas, one is Rio Frio (4100 m) and another Pampa la Bola (4800 m). Meteorological stations were set up in these areas, one each for Chajnantor (5000 m) and Pampa la Bola, two for Rio Frio at two different elevations (4000 m/4200 m).

In July 1995, a 220 GHz tipping radiometer<sup>49)</sup> and an 11 GHz radio seeing monitor were installed at Rio Frio. The radio seeing monitor is an interferometer of two small antennas to receive a geostationary satellite signal and measure the phase fluctuation caused by the atmosphere.<sup>50)</sup> The same set of equipment was installed in 1996 at Pampa la Bola (Fig. 12). By comparing the atmospheric conditions (*e.g.*, weather conditions, atmospheric transmission and radio seeing) and the accessibility, the NAOJ decided the Pampa la Bola–Chajnantor



Fig. 12. (Color online) Site testing instruments and containers at the 4800 m site of Pampa la Bola. Two containers are equipped with solar panels and one of the element antennas of the radio seeing monitor can be seen in the background. (Credit: NAOJ).

region as the best candidate for the LMSA site. As the Pampa la Bola is only a few kilometers apart from the paved international highway from Chile to Argentina, the NAOJ selected the Pampa la Bola area as the array center of the LMSA.

Similar site survey activities in northern Chile were initiated by NRAO for their MMA project and by ESO for their LSA project. The NRAO installed a weather station, a 225 GHz tipping radiometer, and a radio seeing monitor at Llano de Chajnantor.<sup>51)</sup> Through these measurements, NRAO summarized the report entitled “Recommended Site for the Millimeter Array” in 1998.<sup>VII</sup> ESO initially did their own site testing at Pampa de Pajonales near Rio Frio with a weather station, a 183 GHz water vapor radiometer, and a radio seeing monitor, and later joined in the testing at Llano de Chajnantor.<sup>52)</sup>

As the LMSA was intended to achieve the performance at submillimeter wavelengths, the NAOJ considered that the measurement only at 220 GHz was not enough to evaluate the atmospheric transmission and started the measurement directly at submillimeter wavelengths. Therefore, atmospheric opacities at Rio Frio and Pampa la Bora sites were measured at 492 GHz in July 1997 in collaboration with the group of the University of Tokyo. The ratio of opacities at 492 GHz and 220 GHz was  $21.2 \pm 0.4$  which was similar to the value at Maunakea.<sup>53)</sup> More

<sup>VII</sup> <https://www.nrao.edu/archives/files/original/54806a951b049789db8f9d9ce55a8eb1.pdf>.

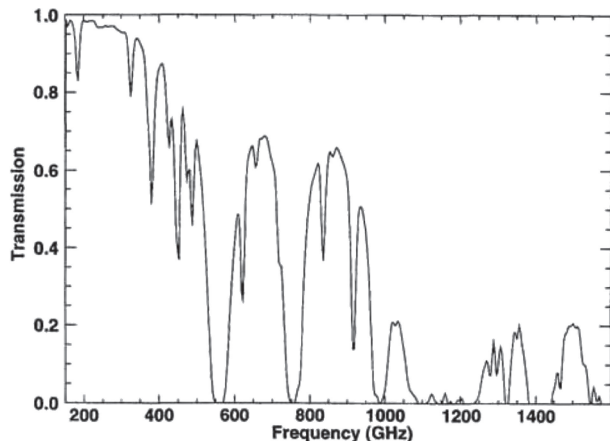

Fig. 13. Atmospheric transmission spectrum from 150 GHz to 1.6 THz obtained using a Fourier-transform spectrometer (Fig. 1 of Ref. 55). The data used for this figure was taken in the morning of June 17, 1998 (southern winter).

extensive studies using a Fourier-transform spectrometer (FTS) were conducted by the NRO group. The atmospheric transmission from 150 GHz to 1.6 THz was measured at Pampa la Bola in June, 1998 (southern winter) with an FTS (Fig. 13).<sup>54,55</sup> The peak transmission in the 650 and 850 GHz windows was found to exceed 60%, and supratherahertz windows around 1.03, 1.35, and 1.50 THz were identified. A tight correlation of millimeter and submillimeter transmission was empirically established and was compared with theoretical models. These studies provided very important information for evaluating transmission at submillimeter wavelengths with measurements at 220 GHz.

In the early 2000s, NAOJ, NRAO, and ESO started joint site testing campaigns at Llano de Chajnantor and Pampa la Bola to pinpoint the candidate site for the central cluster of ALMA and to better characterize the site without duplication of efforts. The site testing instruments were cross-calibrated with side-by-side measurements for detailed comparison of the site testing data. Four radio seeing monitors were used to measure the structure and movement of phase screens aloft the site<sup>56</sup> which was essential for the phase correction technique. Several joint radiosonde campaigns were also conducted.

### 6.3. Final selection of the construction site.

The three parties jointly assessed natural hazards such as seismic hazard and volcanism.<sup>57</sup> The accumulated site testing data for Llano de Chajnantor and Pampa la Bola were finally com-

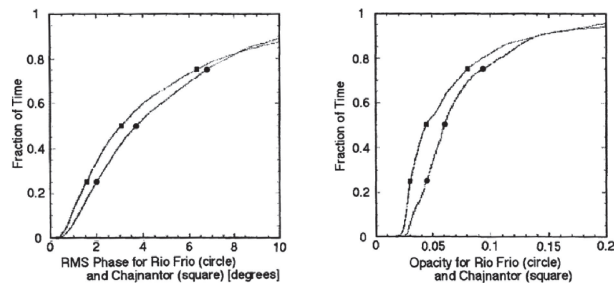

Fig. 14. Cumulative distributions of the rms phase (left) and the opacity (right) at the Rio Frio and Chajnantor sites. These plots only include data when the instruments at both sites were functional. (Fig. 7 of Ref. 48).

pared to select Llano de Chajnantor as the site for the central cluster of ALMA.<sup>58)–61)</sup> Figure 14 shows the comparison of the rms phase and the opacity at the Rio Frio and Chajnantor sites. The final selection of the site was driven not only by atmospheric transmission and phase stability but also by potential snow accumulation, closeness to base camp possibilities or towns. After the final selection of the site, the site characterization activities entered a new phase. The objectives here were to collect necessary information for the construction of infrastructure and instruments. Missing information to be included in the call for vendors was collected. Such information included wind power spectrum,<sup>62)</sup> geotechnical studies,<sup>63)</sup> underground temperature profile and permafrost,<sup>64,65)</sup> soil resistivity,<sup>66,67)</sup> and UV intensity.<sup>68)</sup> To establish a safety guideline for work at the 5000 m altitude site, monitoring of arterial oxygen saturation and pulse rate was done.<sup>69)</sup>

## 7. Instrumental developments for ALMA

**7.1. Interferometer system in millimeter and submillimeter wavelengths.** A radio interferometer system consists of a number of antennas in which receiver front ends are installed, signal transmission lines to connect antennas, and a correlator to obtain correlation between the signals from antennas. The antenna system is required to achieve high surface accuracy (1/10–1/20 of observing wavelength) and pointing accuracy ( $\sim 1/10$  of half power beam width) enough to minimize the loss of signals at millimeter and submillimeter wavelengths. The receiver front end is often composed of cryogenically cooled SIS mixers and local oscillators to achieve low noise temperature in the process of frequency down conversion. In order to minimize the phase error at the front end, the local oscillator should be phase-

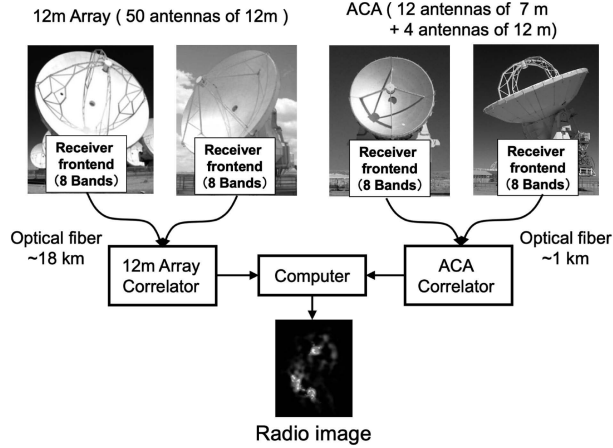

Fig. 15. (Color online) ALMA overall system diagram (as of March 2013).

synchronized to a common reference signal sent from the central building located at the array center. In the ALMA system, the down-converted signal of wide bandwidth is digitized and is sent to the central building through an optical fiber transmission line. At the central building, a large-scale digital correlator system performs correlation analysis between the broadband signal from each antenna. As the total system of ALMA is described in the paper by Wootten, A. and Thompson, A. R. (2009),<sup>70)</sup> we will focus on the developments contributed by Japan.

Simplified system diagram and technical specifications of the ALMA system are shown in Fig. 15 and Table 2, respectively. Basically, the ALMA system is composed of 66 antennas in total with three subsystems, 12 m Array, ACA 7 m Array, and ACA Total Power (TP) Array. The 12 m Array is used for sensitive, high-resolution imaging, while the



Fig. 16. (Color online) Atacama Compact Array (Morita Array) (Credit: ALMA (ESO/NAOJ/NRAO)).

ACA (also known as the Morita Array in honor of Prof. Koh-Ichiro Morita (Fig. 16)) is used to enhance wide-field imaging of extended structures. In this paper, the ACA system is mainly described. The ACA is a system of twelve 7 m antennas (7 m Array) and four dedicated 12 m antennas (TP Array) all equipped with the same set of receiver front ends as those of the 12 m Array. The number and diameter of the 7 m antennas were optimized based on the simulation work.<sup>71)</sup> The 12 m Array and ACA use different independent correlator system. The ACA system is designed to observe visibility function at short baseline lengths which is missing in the observed data only with the 12 m Array (Fig. 17). The TP Array provides a single-dish data to be combined with the data from the 12 m Array. The ACA system recovers the spatially extended components of the objects and significantly enhances the imaging and photometric capability of the ALMA in observing extended astronomical objects in any receiver band (Fig. 18). The ACA is expected to play a particularly important role for observations at high frequencies, where the object is in general larger than the primary beam of the 12 m antenna.

Table 2. Technical specifications of the ALMA system. Two interferometer arrays: 12 m Array and Atacama Compact Array (ACA). The table was made based on Ref. 70.

|            |                     | 12 m Array  | ACA                          |          |
|------------|---------------------|---|------------------------------|----------|
|            |                     |   | 7 m Array                    | TP Array |
| Antennas   | Diameter            | 12 m  | 7 m                          | 12 m     |
|            | Number of Antennas  | 50  | 12                           | 4        |
| Array      | Angular Resolution  | $0.02'' (\lambda/1 \text{ mm}) / (D/10 \text{ km})$ | $5'' (\lambda/1 \text{ mm})$ | —        |
|            | Baseline Lengths    | 150 m–16 km   | 41 m                         | ~70 m    |
| Receivers  | Wavelengths         | 0.3 mm–9.6 mm                                       | 0.3 mm–9.6 mm                | same     |
|            | Number of Baselines | 1225  | 66                           | —        |
| Correlator | Bandwidth           | 8 GHz, Dual pol.                                    | 8 GHz, Dual pol.             | same     |
|            | Spectral Channels   | 4096 per IF   | 4096 per IF                  | same     |

D indicates maximum baseline length (in km), and  $\lambda$  indicates wavelength (in mm).

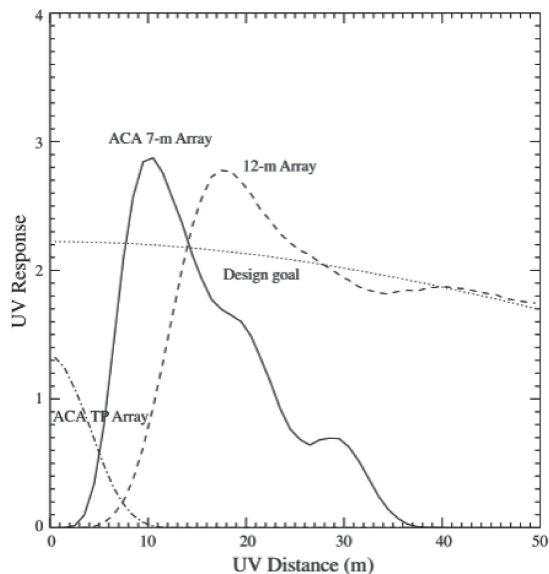

Fig. 17. The UV response profiles of the 12m Array (dashed line), the 7 m Array (solid line) and the TP Array (dash-dotted line) (Fig. 3 of Ref. 72) which includes projected baselines in addition to physical baselines. The UV plane is a Fourier transform of the image plane, and the UV distance is the radial distance from the center of the coordinates. The TP Array and the 7 m Array fill the gaps in UV coverage of the 12m Array.

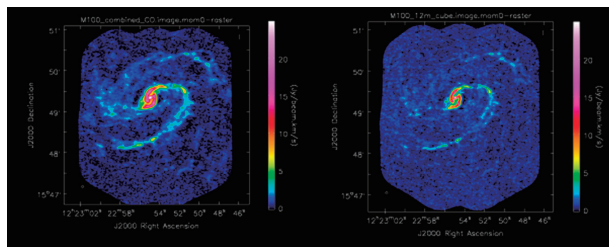

Fig. 18. Intensity distribution of CO molecular line toward M100 galaxy obtained with and without ACA. The image with ACA (left) shows extended distribution of molecular gas that is barely seen in that without ACA (right). The figure was redrawn based on the original figures in CASA Guides.<sup>VIII</sup>

**7.2. High precision antennas.** All the ALMA antennas are relocatable using specially designed transporters to change the array configuration and to bring the antennas for maintenance to and from Operation Support Facility (OSF).

For a radio telescope operating at millimeter and submillimeter wavelengths, high-precision parabolic antenna is the largest and the most costly subsystem. Its role is to collect faint radio signals from distant astronomical objects. Its surface error must be

significantly smaller than the shortest wavelength of the radio waves to be observed, and associated technical challenges include control of deformation of such a large structure due to gravity, heat, and wind. Accurate pointing and tracking of the telescope are additional challenges. For ALMA, such high performance shall be realized under exposed conditions since any types of enclosures (radome or astrodome) are rejected because of the transportability, close-packing capability, and shadowing.

In Japan, the development of large high-precision antennas for radio astronomy dates back to that of the NRO 45 m telescope in collaboration with Mitsubishi Electric Corporation (MELCO). The telescope has a main reflector composed of about 600 CFRP-Al honeycomb sandwich panels. The panels are supported by a steel backup structure with shades and air circulation against thermal deformation, and with homologous deformation design that keeps the deformation of the main reflector due to gravity less than  $\sim 100 \mu\text{m}$  rms from the best-fit paraboloid at any elevation angle between  $40^\circ$  and  $80^\circ$ . The displacements of the panels are measured by the holography technique and are adjusted by actuators that support the panels.

Prototyping for the future submillimeter telescope was conducted as a collaboration between NAOJ and MELCO. A 10 m antenna was developed as the sixth element of the NMA with a conventional design with Al honeycomb panels. Through evaluation of the performance of this antenna, superiority of machined Al panels was recognized,<sup>73)</sup> and it was verified with the ASTE 10 m antenna developed in 2000.<sup>74)</sup>

Based on the scientific requirements and technical feasibility, ALMA 12 m antennas were specified to have a surface accuracy of  $<25 \mu\text{m}$  rms, point to within  $2''$  rms and track objects to  $0.6''$  rms (Table 3).

Table 3. Antenna specifications. The table was made based on the ALMA Cycle 9 Technical Handbook.<sup>IX</sup>

|                | 12 m Array              | TP Array | 7 m Array             |
|----------------|-------------------------|----------|-----------------------|
| Diameter       | 12 m                    | 12 m     | 7 m                   |
| Surface error  | $<25 \mu\text{m}$ rms   |          | $<20 \mu\text{m}$ rms |
| Pointing error | $<0.6''$ rms (relative) |          | $<2''$ rms (absolute) |
| Max speed      | 6°/sec (AZ)             |          | 3°/sec (EL)           |

<sup>VIII</sup> [https://casaguides.nrao.edu/index.php/M100\\_Band3\\_Combine.4.3](https://casaguides.nrao.edu/index.php/M100_Band3_Combine.4.3).

<sup>IX</sup> <https://almascience.nao.ac.jp/documents-and-tools/cycle9/alma-technical-handbook>.



Table 4. Comparison of the structure of EA, NA, and EU antennas. The table was made based on Refs. 72, 75 and ALMA Cycle 9 Technical Handbook.<sup>IX</sup>

|                      | 7 m antenna<br>(EA: MELCO)                                     | 12 m antenna<br>(EA: MELCO)                  | 12 m antenna<br>(NA: Vertex)  | 12 m antenna<br>(EU: AEM)                      |
|----------------------|--|--|---|--|
| Number               | 12   | 4  | 25  | 25   |
| Main reflector panel | Machined Al;<br>88   | Machined Al;<br>205                          | Machined Al;<br>264   | Al honeycomb + Ni skin;<br>120                 |
| Backup structure     | Truss-structure of insulated steel with forced air circulation | Truss-structure of CFRP tubes & Invar joints | Box-structure of CFRP boards  | Box-structure of CFRP boards                   |
| Quadrupod            | Conventional; “+”-shaped                                       | Arched; “+”-shaped                           | Arched; “+”-shaped  | Conventional; “×”-shaped                       |
| Receiver cabin       | Insulated steel; air-cooled                                    | Insulated steel; air-cooled                  | Insulated steel; water-cooled   | CFRP   |
| Drive mechanism      | Direct drive   | Direct drive                                 | Anti-backlash gear drive  | Direct drive                                   |
| Metrology            | Reference Frame  | Thermal (main dish), Reference Frame         | 4 linear displacement sensors + 1 two-axis tiltmeter (above the AZ bearing) | 86 thermal sensors + 2 tiltmeters in yoke arms |

The antennas are operated at an altitude of 5000 m, and under the temperature range between  $-20^{\circ}\text{C}$  and  $+20^{\circ}\text{C}$ . Regarding the primary operational conditions for the antenna design, it is assumed that the operable average wind speed is 9 m/s without solar radiation and temperature gradient during nighttime, and the operable average wind speed is 6 m/s with the solar radiation of  $1290\text{ W/m}^2$  and the temperature gradient of  $0.6^{\circ}\text{C}/10\text{ min}$  and  $1.8^{\circ}\text{C}/30\text{ min}$  during daytime.

The 12 m antennas were procured by three Executives—25 from Vertex RSI (North America) procured by NRAO, 25 from Alcatel Alenia Space European Industrial engineering MT Aerospace (AEM, Europe) procured by ESO, and 4 from MELCO by NAOJ. The three manufacturers met the ALMA specifications with different design concepts as summarized in Table 4. This competitive situation minimized the risks of non-conformance of the high specifications and schedule slippage, though there was an increase of operational complexity and overhead of spare parts. This distributed procurement also realized a fair regional share of budget spending consequently.

To meet the high specifications required for ALMA, the deformation of the main reflector due to the gravity, heat load, and wind shall be minimized. The MELCO 12 m antenna uses a truss structure of carbon fiber reinforced plastic (CFRP) tubes and invar joints (Fig. 19). The truss structure of CFRP tubes and invar joint had already been used for the

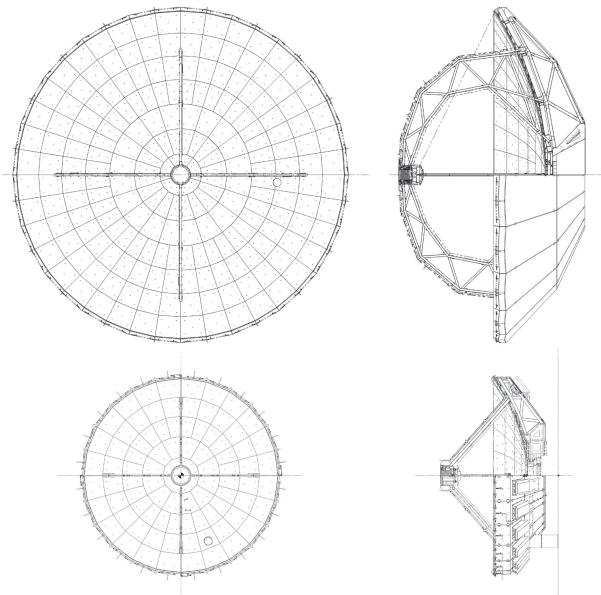

Fig. 19. Front and side views of the main reflectors of the ACA 12m (upper) and 7m (lower) antennas (Drawing Courtesy: MELCO).

ASTE 10 m antenna and evaluated to be good enough to meet the requirement for the ALMA 12 m antennas. On the other hand, the MELCO 7 m antenna uses a truss structure of steel tubes with forced air circulation system and thermal insulation (Fig. 19). The reason why the steel truss structure was adopted is to balance the weight of the main

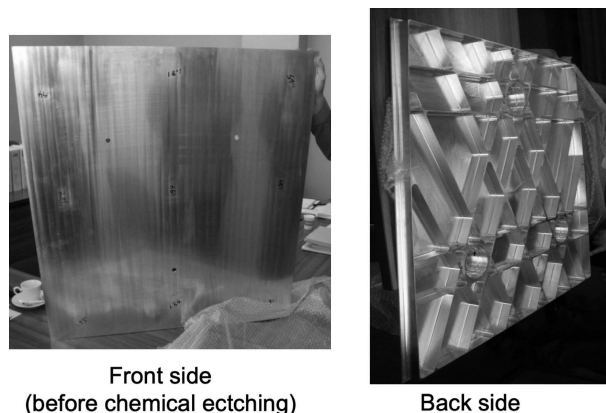

Fig. 20. (Color online) An example of the prototype surface panel (Credit: NAOJ).

reflector with that of the receiver cabin and reduce the costs by not using expensive materials such as CFRP and Invar.

The panels of the main reflector were machined from aluminum block by NC machine. Rib structure in the backside is also machined to achieve the low weight ( $\sim 10 \text{ kg/m}^2$ ). Repeatability of manufacturing was greatly improved compared with the conventional honeycomb panel. The surface of the panel was chemically etched to scatter the sunlight for solar observations without impairing the efficiency in sub-millimeter wavelength. Each panel is supported at 5 (or 3) supporting points with adjusting screws to larger honeycomb boards fixed to the backup structure. Misalignment of the panels is measured with holography method and is adjusted with a dedicated tool by rotating the adjusting screws (Fig. 20).

The MELCO antenna uses a direct drive system. The direct drive system has the following advantages over the anti-backlash system. (1) There is no contact between the moving and the fixed structure which causes no friction and backlash. (2) There is no degradation of stiffness which usually happens in the case of gear drive systems. (3) The direct drive system does not create lateral force which usually happens in the case of anti-backlash gear drive systems.

For the AZ/EL mount, it is extremely costly and thus impractical to use special material such as CFRP. Metrology system was thus introduced to monitor the structure deformation due to wind and thermal effects to correct the pointing error in real time. The MELCO antennas adopted a metrology system with invar reference frames located inside both the yoke and the pedestal. The inner yoke frame

detects a displacement of the EL axis relative to the AZ bearing. The inner pedestal frame detects a displacement and inclination of the AZ bearing relative to the pedestal. The position sensors attached to the reference frame detect the mechanical deformation of the antenna mount in real time.

Before the construction, NRAO and ESO built one each prototype antenna for the 12m Array to evaluate their performance at the ALMA Test Facility (ATF) in the NRAO VLA observatory in New Mexico, U.S.A.<sup>76),77)</sup> NAOJ also constructed a prototype 12m antenna for the Total Power Array and tested its performance at the ATF.<sup>78)</sup> It turned out that all these prototype antennas meet specifications for ALMA.

**7.3. Low noise receivers.** The role of a heterodyne receiver is to down convert the signal to lower frequency bands using a set of local oscillators (LOs) and mixers for easier handling and amplify it with low-noise amplifiers. Superconductor-Insulator-Superconductor (SIS) tunneling junctions have recently been used for mixers operating in millimeter and submillimeter wavelengths because of the high nonlinearity for mixing and the operability under low ( $\sim 4 \text{ K}$ ) temperature environment for thermal noise reduction. Development of SIS mixers in Japan was initially led by NRO.<sup>79),80)</sup>

A simple SIS junction has an intrinsically narrow bandwidth. To solve this issue, parallel-connected twin junctions (PCTJ) are designed to resonate at the band center to tune out the junction geometric capacitance.<sup>81)</sup> Inhomogeneous distributed junction arrays as an extension of the PCTJ concept have a rather large bandwidth in comparison to conventional SIS junction devices, while keeping a quantum-limited noise performance.<sup>82)</sup>

The ALMA front end can accommodate up to 10 receiver bands covering most of the wavelength range from 35 to 950 GHz. Each band is designed to cover a tuning range which is approximately tailored to the atmospheric transmission windows (Fig. 21).

The specifications of the ALMA receivers were so challenging, and no institute in the world at that time had proven technology necessary for the development. The required sensitivity in each band is very close to the theoretical quantum limit of  $h\nu/k$ .

Out of seven frequency bands (Bands 3, 4, 6, 7, 8, 9, 10) originally installed for ALMA, NAOJ contributed to the development of three frequency bands—Band 4 (125–163 GHz), Band 8 (385–500 GHz), and Band 10 (787–950 GHz) (Table 5). Band 4 is in the millimeter range, and Bands 8 and

Table 5. Specifications of ALMA receivers. The table was made based on the Table 4.1 in ALMA Cycle 8 2021 Technical Handbook.<sup>X</sup>

| Band | Frequency range (GHz) | Sideband mode | IF range (GHz) | T <sub>rx</sub> over 80% of band (K) | T <sub>rx</sub> at any frequency (K) |
|------|-----------------------|---------------|----------------|--------------------------------------|--------------------------------------|
| 3    | 84.0–116.0            | 2SB           | 4–8            | <39                                  | <43                                  |
| 4    | 125.0–163.0           | 2SB           | 4–8            | <51                                  | <82                                  |
| 5    | 158.0–211.0           | 2SB           | 4–8            | <55                                  | <75                                  |
| 6    | 211.0–275.0           | 2SB           | 4.5–10         | <83                                  | <136                                 |
| 7    | 275.0–373.0           | 2SB           | 4–8            | <147                                 | <219                                 |
| 8    | 385.0–500.0           | 2SB           | 4–8            | <196                                 | <292                                 |
| 9    | 602.0–720.0           | DSB           | 4–12           | <175 (DSB)                           | <261 (DSB)                           |
| 10   | 787.0–950.0           | DSB           | 4–12           | <230 (DSB)                           | <344 (DSB)                           |

Fig. 21. (Color online) The ten ALMA receiver bands along with atmospheric transmission.<sup>XI</sup>

Fig. 22. (Color online) Band 4, Band 8, and Band 10 receiver cartridges (from left to right) developed by NAOJ (Credit: ALMA (ESO/NAOJ/NRAO)).

10 lie in the submillimeter range. Both Bands 8 and 10 are key to the science in observations of submillimeter lines since these bands cover [CI]  $^3P_1$ - $^3P_0$  and  $^3P_2$ - $^3P_1$  lines, respectively. It is noteworthy that NAOJ is the only institute that developed three receiver bands simultaneously (Fig. 22).

To promote receiver development for ALMA, the NAOJ Advanced Technology Center (ATC) played an important role. ATC was established in NAOJ as the research center for advanced instrumentation and technology development for both ground-based and space astronomy with wavelengths ranging from radio through ultraviolet. ATC designs, develops, manufactures, and tests critical components vital for advanced instrumentation as well as

<sup>X</sup> <https://almascience.nao.ac.jp/documents-and-tools/cycle8/alma-technical-handbook/>.

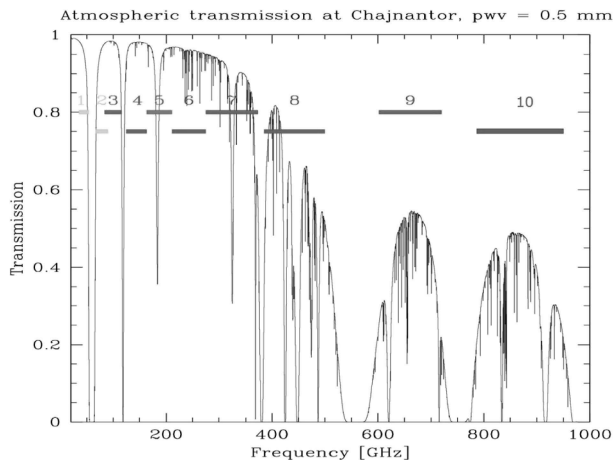
<sup>XI</sup> <https://almascience.nao.ac.jp/documents-and-tools/cycle3/alma-technical-handbook/>.

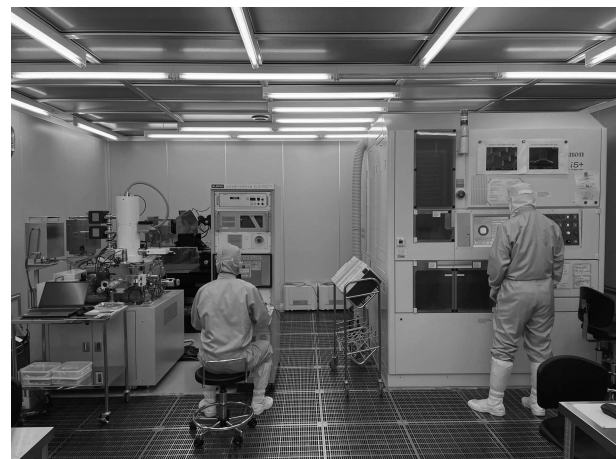

Fig. 23. (Color online) The clean room for the SIS junction development at NAOJ Advanced Technology Center (Credit: NAOJ).

the instrument systems. Such instruments include SIS junctions, mirrors, and horns used to detect faint astronomical signals in the millimeter and submillimeter wavelengths. ATC owns world-class equipment such as high-quality clean rooms (Fig. 23) for the ALMA SIS mixers, ion-beam sputtering machine for thin-film coating, and precision machinery. As of 2021, ATC consists of approximately 50 staff scientists, engineers and technicians including contract-based personnel as well as graduate students working with a wide range of instrument developments. The success with minimal resources is largely thanks to the intimate collaboration and synergy with the development of the other bands in ATC such as sharing of test facilities and know-hows.

A mixer converts the original RF signal into two IF signals as a beat between the RF and LO frequencies. A double-sideband (DSB) mixer is a three-port device that mixes up RF signals from upper ( $\nu_{\text{RF}} = \nu_{\text{LO}} + \nu_{\text{IF}}$ ) or lower ( $\nu_{\text{RF}} = \nu_{\text{LO}} - \nu_{\text{IF}}$ ) sidebands with LO and outputs only one IF, whereas a single sideband (SSB) mixer separates RF signals from upper and lower sidebands and outputs IF that corresponds to only one of upper or lower sideband. To fully utilize the incoming signal, use of both sidebands is needed, and the sideband-separating (2SB) mixer with two IF outputs is applied when possible. Use of both polarizations is also important to double the sensitivity and to measure the polarization of the astronomical sources. Dual polarization receiver can be realized either by putting optics such as a wire grid in front of two horns each of which feeds a mixer, or by inserting an orthomode transducer after a multimode horn and feeding the separated RF signals to two mixers.

The receivers for Bands 3 to 8 are 2SB receivers, where both the upper and lower sidebands are provided separately and simultaneously. There are 4 outputs from each of the receivers, comprising the upper and lower sidebands in each of the two polarizations. Because of the technical difficulties, Bands 9 and 10 use DSB receivers, where the IF contains noise and signals from both sidebands. They only have two outputs, one per polarization (ALMA Cycle 8 2021 Technical Handbook).<sup>X</sup>

The Band 4 receiver<sup>83)</sup> consists of three elements: a warm optics, a cold cartridge assembly (CCA), and a warm cartridge assembly (WCA). The Band 4 CCA includes a feed horn,<sup>84)</sup> an orthomode transducer (OMT) as a polarization splitter,<sup>85)</sup> 2SB SIS mixer assemblies, cold IF amplifiers, isolators, and frequency doublers.

The Band 8 receiver<sup>86)</sup> adopted 2SB mixer of IF 4–8 GHz instead of DSB mixer of IF 4–12 GHz because the atmosphere in the 400 GHz band has several deep absorptions by H<sub>2</sub>O and O<sub>2</sub>. The sideband separation scheme is based on the design developed for the Band 4 receiver.

Band 10 is the highest frequency band of ALMA receivers. The development of the SIS mixers operating in this frequency range was extremely difficult because there are large losses from pair-breaking above the superconducting gap frequency of Nb ( $\sim 700$  GHz), which is commonly used for SIS junctions. NbTiN with a critical temperature of about 15 K and with larger gap frequency ( $\sim 1.2$  THz) was selected instead. The Band 10 receiver<sup>87)</sup> thus uses two DSB mixers with Nb/AIO<sub>x</sub>/Nb tunnel junctions and NbTiN/SiO<sub>2</sub>/Al microstrip tuning circuits on quartz substrate (Figs. 24 and 25).

**7.4. Photonic LO.** For a local oscillator (LO) in millimeter wavelengths commercially available oscillators, such as Gunn oscillator, can be used. However, it is difficult to find an oscillator which can generate a signal in submillimeter wavelengths directly, and a chain of frequency multipliers after the oscillator are required. A photonic LO is expected to play an important role in the next generation receivers, because of its wide tunability with a relatively simple system, high spectral purity, little loss of power for long-distance transmission thanks to the usage of optical fibers, and no need of mechanical tuning. Development of such photonic LO in Japan was done as a collaborative project between the NAOJ and the NTT. A W-band waveguide photo mixer was fabricated at the NAOJ<sup>88)</sup> using a uni-traveling-carrier photodiode (UTC-PD) developed by the NTT. The performance of this waveguide photo mixer as a photonic LO was demonstrated by an astronomical observation with the NRO 45 m radio telescope.<sup>89)</sup> Although the photonic LO is a very promising device for the local oscillators, the ALMA baseline plan was already a research and development phase success, and the plan for the ALMA photonic LO system proposed by the NAOJ was considered as a back-up plan.

**7.5. Cryocooler.** To keep the SIS mixers and low-noise amplifiers at necessary low temperature, a cryocooler that can reach  $\sim 4$  K is needed. Since 1987, Gifford-McMahon (GM)–Joule-Thomson (JT) cryocoolers specially developed for radio astronomy by Sumitomo Heavy Industries (SHI) have been used at NRO. Their performance was tested under a very cold environment ( $\sim -25$  °C in winter at night), and

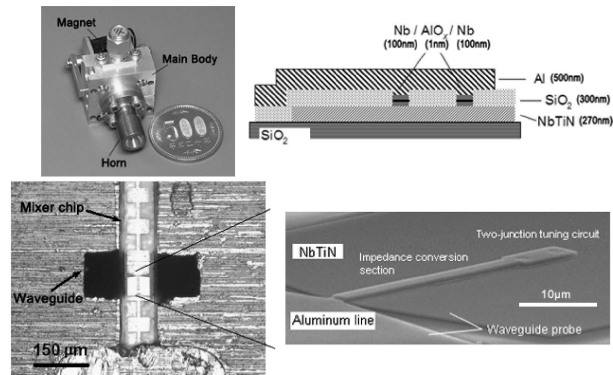

Fig. 24. (Color online) Submillimeter (terahertz) receiver system using NbTiN (upper left). Superconductive integrated circuit using NbTiN, micrographed by an electron microscope (lower right) and its cross-section structure (upper right). (Credit: NAOJ).<sup>XII</sup>



Fig. 26. (Color online) Receiver dewar that accommodates receiver cartridges and a GM cryocooler (Credit: NAOJ).

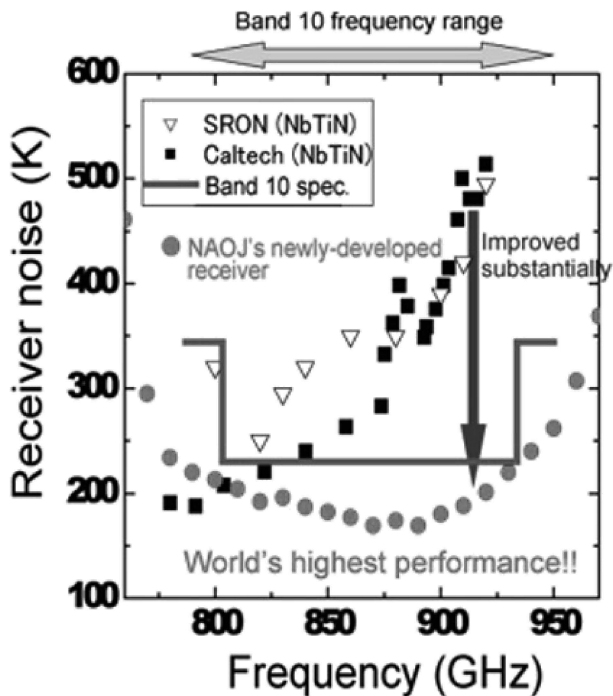

Fig. 25. (Color online) Frequency dependence of the receiver noise temperature of Band 10 receiver developed by NAOJ. Previously, the world's highest performance of the 750 to 950 GHz receiver (operation temperature at 4 K) was achieved by the California Institute of Technology, and SRON (Netherlands Institute for Space Research: one of the major research institutes in Europe). The NAOJ research team has succeeded in improving the performance substantially with its newly developed receiver (Credit: NAOJ).<sup>XIII</sup>

some design modifications were made based on these tests. This collaborative work made SHI as the world-leading company in this area.

The ALMA cryocooler is specified to have a 110 K stage for radiation shield, a 15 K stage for low-noise amplifiers, and a 4 K stage for SIS mixers, with temperature ranges of 70–130 K at the 0–2.5 W heat load for the 110 K stage, 10–18 K at the 0–200 mW heat load for the 15 K stage, and <4 K at the 0–108 mW heat load for the 4 K stage, respectively. Their respective temperature stabilities were specified to be better than 2 mK, 50 mK, and 100 mK on timescales of 100 s or less.<sup>XIII</sup> SHI developed a three-stage GM 4 K cryocooler that meets this specification, and it was selected by Rutherford Appleton Laboratory (RAL) as one of the European deliverables for ALMA (Fig. 26). At the 4 K stage, a He-pot connected to an external buffer tank was added for temperature stabilization by a factor of  $10^{90}$  by using the very large specific heat of liquid He at 4 K. Change of the inclination of the cryocooler installed in the receiver cabin in accordance with the elevation movement was an additional issue, because the cooling performance of the GM cryocooler at that time was degraded by internal convection if the lower temperature stage is located above the higher one. This problem was solved by a patented spiral seal method.<sup>90</sup> Regular maintenance of the cryocoolers operated at the remote site without any nearby SHI service center is also a challenge. SHI specially allowed JAO to conduct replacement of some of the parts, with a special training and document hand-over. This minimized the downtime and maintenance cost.

<sup>XII</sup> <https://alma-telescope.jp/en/news/press/mt-06-3>.

<sup>XIII</sup> “Cryostat Technical Specifications”, [https://library.nrao.edu/public/memos/alma/misc/ALMAU\\_28.pdf](https://library.nrao.edu/public/memos/alma/misc/ALMAU_28.pdf).

**7.6. Digital correlator.** As shown in Fig. 15, the ALMA system has two different digital correlators, one for the 12m Array and another for the ACA. Both correlator systems can be operated independently or simultaneously. For the  $N$ -antenna array there are  $N(N-1)/2$  antenna pairs. The Baseline Correlator or BLC performs correlation calculations for 1225 antenna pairs of the 12 m Array and the ACA Correlator for 120 antenna pairs of the ACA. The instantaneous bandwidth of each front-end receiver is unified as 7.5 GHz. For Bands 3 to 8, 2SB mixers are used with the IF frequency of 4–8 GHz with an exception for the band 6 of the IF frequency of 4.5–10 GHz, while for Bands 9 and 10, DSB mixers are used with the IF frequency of 4–12 GHz. The analog output signals from the IF system form four baseband signals, each covering a bandwidth of 2 GHz in two orthogonal linear polarizations are digitized at the sampling frequency of 4 GHz with 3 bit digitizers, and then transferred via optical fiber cable to the central building where BLC and ACA Correlators are located.

There are four outputs from each of the receivers, comprising the upper and lower sidebands in each of the two linear polarizations. Both correlators can produce four sets of cross correlation products,  $\langle XX^* \rangle$ ,  $\langle XY^* \rangle$ ,  $\langle YX^* \rangle$ ,  $\langle YY^* \rangle$  where  $X$  and  $Y$  stand for two linear polarizations and  $*$  complex conjugate. After correcting for the parallactic angle, the Stokes Parameters of  $I$ ,  $Q$ ,  $U$ ,  $V$  are obtained from these correlation products. In the course of earth rotation, the projected interferometer baselines change their lengths and orientations to form the two-dimensional plane of the Visibility Function from which the map of the brightness distribution can be obtained by two-dimensional Fourier transform using the aperture synthesis theory.<sup>91)</sup> Both correlator systems generate auto-correlation products simultaneously with cross-correlation products, and are used not only for the TP Array spectroscopy but also for normalization of the cross products. The time varying delay and phase of the received signal due to the earth rotation are corrected before the calculation of cross correlation.

Another important function of the correlators is to calculate the frequency spectrum of the incoming celestial signals to observe molecular spectral lines. There are two major types of architectures for digital correlators – XF and FX types. The “X” and “F” mean multiplication and Fourier transform, respectively. The XF type generate the cross-correlations function of incoming signals in time domain first

and then Fourier-transformed to obtain the cross-correlation spectra, whereas the FX type generate the Fourier transform of the incoming signal to obtain the complex voltage spectra and then multiplied to obtain the cross-correlation spectra. In 1987, an FX-type correlator system was successfully developed at NRO for the first time in the world.<sup>92)</sup> It was used for the NMA high frequency resolution observations with 320 MHz bandwidth and 1024 frequency channels. The BLC adopted the XF architecture, while the ACA the FX architecture. The NAOJ decided to adopt the FX architecture for the ACA Correlator because of the long experiences at NRO and developed the correlator with a collaboration with Fujitsu Advanced Engineering.<sup>93)</sup> A prototype FX correlator was developed at NRO in order to verify its design and implementation prior to the development of the ACA Correlator.<sup>94)</sup> In the following the ACA Correlator is mainly described based on Refs. 93 and IX (Figs. 27 and 28).

In the ACA Correlator, the incoming time-domain data stream is converted in frequency-domain spectrum via the FFT (Fast Fourier Transform) module before cross multiplication to form the power spectrum. The FFT module always accepts a full 2 GHz bandwidth signal and performs 1 M ( $2^{20}$ )-point FFT and generates 524288 ( $2^{19}$ ) channel spectra with a frequency resolution of 3.815 kHz

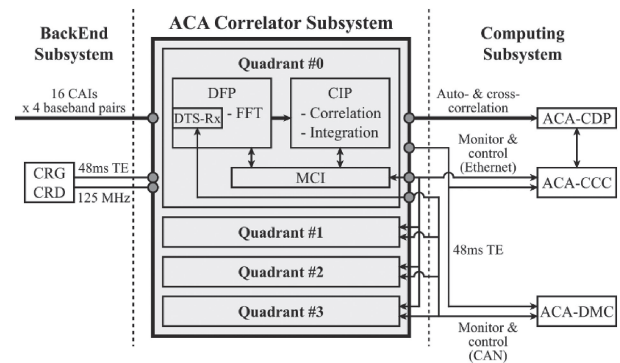

Fig. 27. System block diagram of the ACA Correlator-Subsystem. The correlator is controlled by the ACA Correlator Control Computer (ACA-CCC) through Ethernet. Optical data receivers on the DFP modules are controlled by the ACA Data transmission system receiver Monitor and Control computer (ACA-DMC) to maintain the compatibility with the BLC. Processed data are output from the CIP modules to the ACA Correlator Data Processor (ACA-CDP) for their post-processing. 48ms timing event and 125 MHz reference signals are supplied from the Central Reference Generator (CRG) and the Central Reference Distributor (CRD) in the Backend Subsystem, respectively.<sup>93)</sup>



Fig. 28. (Color online) ACA Correlator (Credit: NAOJ).

(= 2 GHz/512k frequency channels) which is better than 5kHz required by ALMA. In the FFT calculations, 16 bit fixed-point number is used to decrease the calculation noise by number rounding and to achieve the required dynamic range and sensitivity loss. At this stage, the total required data rate is  $\sim 2150$  Tbps. After the FFT, in order to reduce the data rate and the size of the X-part, the complex values are re-quantized to 4 bit real and 4 bit imaginary numbers. The auto- and cross-correlations are calculated, and the maximum number of 8192-point spectra are generated for each antenna pair/polarization pair. The FX design enables output with multiple spectral windows with different channel spacings by averaging multiple channels (flexible spectral binning).

**7.7. Computing.** ALMA's computing performs the following functions. First, it controls all instruments, performs observational operations, and archives observed data for scientists. It also provides support to scientists by assisting them in the preparation of observation proposals and by providing the Common Astronomy Software Applications (CASA),<sup>XIV</sup> a software package for analyzing observed data. In addition, there is the activity called as Science Software Requirements (SSR), which identifies the scientific software requirements that ALMA should have.

The Integrated Computing Team was formed because software development for these functions requires the EA, EU, and NA to work together. East Asia, led by Japan, contributed 25% to Computing, the same percentage with other deliverables from East Asia. This contribution included the participation of Taiwanese engineers and partial reimbursement of expenses for engineers hired in Europe and

the United States. The focus of the computing development by East Asia was in the ACA antenna control and the ACA Correlator software, but it included subsystems such as pipeline, offline, observation preparation, observation scheduling, telescope calibration, and integrated test systems, as well as participation in SSR activities. These software developments were performed on distributed computers at various sites in a well-defined interface environment. Specifically, they were realized in a distributed object environment using CORBA (Common Object Request Broker Architecture).

The observed data with ALMA are archived and used by scientists for data analysis as follows.<sup>95)</sup> The Joint ALMA Observatory (JAO), the operational entity of ALMA, consists of the Array Operations Site (AOS: 5000 m above sea level), the Operations Support Facility (OSF: 2900 m above sea level), and the ALMA Santiago Central Office (SCO). The observed signals are correlated in real time by the correlators at AOS and the correlated data are stored in the front-end archive at OSF. The data temporarily stored at OSF are sequentially transferred to the Primary Science Archive System at SCO, and then mirrored to the Secondary Science Archive System at ALMA Regional Centers (ARC) in EA, EU, and NA. The Science Archive stores 200 TB of data per year.

At SCO, pipeline processing is driven by the arrival of observed data, and the routinely processed data are also archived. On the other hand, at each ARC, the scientists or ARC staff can specify any processing parameters and perform science-specific processing for each scientist. The data pipelined at SCO are also mirrored in each ARC, so that scientists in that region can have access to both raw and pipelined data from the ARC archive system. Preservation of archived data is one of the most important requirements for an observatory. In the case of ALMA, back-up is not necessary because the same data is stored in multiple ARCs (EA, EU, and NA ARCs). If data is corrupted in any of ARCs, it will be mirrored from another ARC.

## 8. Initial science results with ALMA

**8.1. Science verification and early science with a partially completed array.** The first ACA 12 m antenna was handed over to JAO in December 2008 as the first ALMA antennas. Since then, the antennas were handed over to JAO by ESO/NAOJ/NRAO in a steady manner for science verification. Similarly, essential components such as receivers and

<sup>XIV</sup> <http://casa.nrao.edu>.

correlators as well as the supporting infrastructure were delivered step-by-step.

When the capability of the partially completed array consisted of the available antennas well exceeding those of the other existing facilities, ALMA entered an initial science phase called “Early Science Cycle 0”. The Cycle 0 Call for Proposals (CfP) was issued on March 30 of 2011, with a proposal submission period from June 1–30, 2011. It was anticipated that 500–700 hrs of observing time would be available over a 9-month period.

The proposals were evaluated by the time allocation committee (TAC). There were potentially two alternative ways of selecting observation proposals—single or regional TACs, and there are pros and cons with these alternatives. The single TAC is a simple solution and is suitable for prioritizing the proposals based on science merits and minimizing the duplication of successful proposals. Having regional TACs allows more flexibility to the regional science community in terms of prioritization of the proposals (*e.g.*, large regional programs, student proposals *etc.*). After some intensive discussions during the construction phase, the ASAC finally agreed to create a single TAC. Some observation time for non-ALMA partners was also spared.<sup>XV</sup> The distribution of proposals by scientific category demonstrates that ALMA covers very wide fields in astrophysics (Fig. 29).

The first scientific image taken with ALMA was published on October 3, 2011. Although the number of available antennas was still very limited at that time, the image of the Antennae galaxies already revealed a view of the Universe that cannot be observed in other wavelengths or with other existing facilities (Fig. 30).

**8.2. Initial science results.** On March 13, 2013, ALMA was inaugurated at an official ceremony, which marked the completion of all the major systems of the giant telescope and the formal transition from a construction project to a fully-fledged observatory.<sup>XVI</sup>

To demonstrate the high spatial resolution of ALMA, the initial long-baseline campaign was held during the period from 2014 September to November,<sup>96)</sup> and some breathtaking images were released.

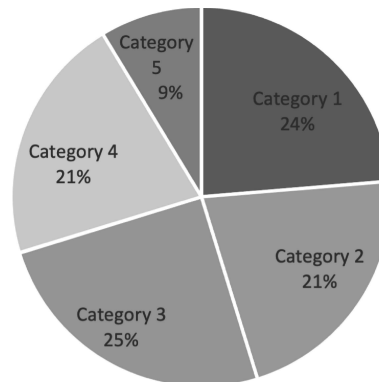

Fig. 29. (Color online) Distribution of proposals for Cycle 7 (Oct 2020–Sep 2021) by scientific category (Category 1: Cosmology and the high redshift universe; Category 2: Galaxies and galactic nuclei; Category 3: ISM, star formation and astrochemistry; Category 4: Circumstellar disks, exoplanets, and the solar system; Category 5: Stellar evolution and the Sun). The figure was redrawn based on the Table 2 in ALMA Cycle 7 Stats.<sup>XVII</sup>



Fig. 30. The ALMA/HST composite image of the Antennae galaxies (also known as NGC 4038/4039), which are a pair of interacting spiral galaxies about 70 million light-years away. The HST optical image—shown mainly in blue—reveals the newborn stars in the galaxies, whereas the ALMA image—shown in red, pink, and yellow—shows us the dense and cold molecular gas from which new stars form. (Credit: ALMA (ESO/NAOJ/NRAO). Visible light image: the NASA/ESA Hubble Space Telescope).

Such images include the resolved disk of the newborn star called HL Tau (Fig. 31)<sup>97)</sup> and the lensed galaxy behind a cluster of galaxies (Fig. 32).<sup>98)</sup>

<sup>XV</sup> <https://safe.nrao.edu/wiki/pub/ALMA/2006f2f/StructureofanALMAPRC.pdf>.

<sup>XVI</sup> <https://www.almaobservatory.org/en/press-releases/alma-inauguration-heralds-new-era-of-discovery/>.

<sup>XVII</sup> <https://almascience.nao.ac.jp/documents-and-tools/documents-and-tools/cycle7/alma-cycle7-stats>.



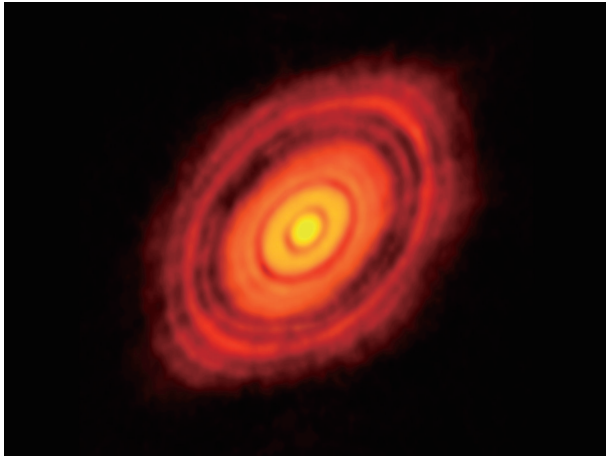

Fig. 31. ALMA image of the protoplanetary disk around the young star called HL Tauri. It reveals substructures within the disk that have never been seen before, with concentric gaps indicating the possible orbits of forming giant planets. The first and second innermost gaps have sizes comparable with the orbits of Saturn and Uranus. (Credit: ALMA (ESO/NAOJ/NRAO)).

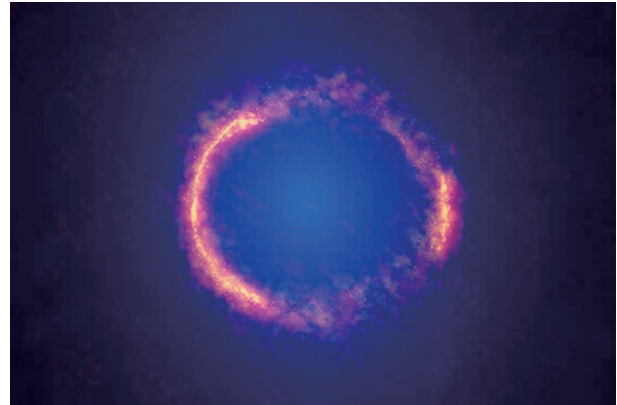

Fig. 32. The ALMA/Hubble composite image of the gravitationally lensed galaxy SDP.81. The ALMA image shown as an orange ring indicates the distribution of dust and molecular gas in this distant galaxy, distorted and partially amplified to form this Einstein Ring feature. The diffuse blue element at the center of the ring is from the intervening lensing galaxy, as seen with the HST. (Credit: ALMA (NRAO/ESO/NAOJ); B. Saxton NRAO/AUI/NSF; NASA/ESA Hubble).

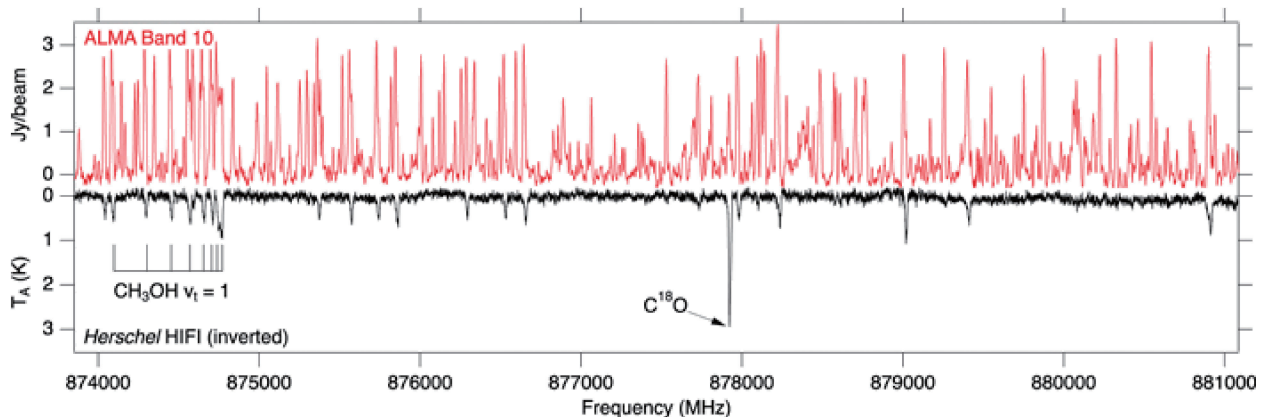

Fig. 33. Comparison of ALMA Band 10 spectra toward NGC 6334I MM1 (top) with the inverted spectra retrieved from the *Herschel* archive (bottom).<sup>99)</sup> Molecular lines from compact regions are more clearly visible in ALMA compared with larger-scale *Herschel* data, while extended C<sup>18</sup>O emission is almost resolved out in the ALMA data.

One example of the highest frequency (Band 10) observations that demonstrates the high spectroscopic capability is the spectral line survey of the massive-star-forming region NGC 6334I.<sup>99)</sup> They detected 695 spectral lines with ALMA, while only 65 were found in the *Herschel* HIFI spectral line survey data. The detected species included complex organic molecules such as glycolaldehyde (HC(O)-CH<sub>2</sub>OH) (Fig. 33).

Because of the extremely high science productivity of ALMA in full operation, overview of the science highlights is far beyond the scope of this paper. The up-to-date information is available

through the ALMA webpage at <https://www.almaobservatory.org/>.

**8.3. Participation in EHT and imaging of black hole shadow.** Event Horizon Telescope (EHT) is an Earth-sized radio interferometer with large radio telescopes spreading over the world. In the 2017 campaign, ALMA, APEX, IRAM 30m telescope, James Clerk Maxwell Telescope (JCMT), Large Millimeter Telescope Alfonso Serrano, Submillimeter Array (SMA), Submillimeter Telescope (SMT), and South Pole Telescope participated.<sup>100)</sup>

With extremely large sensitivity in short millimeter wavelengths, ALMA played a key role in this

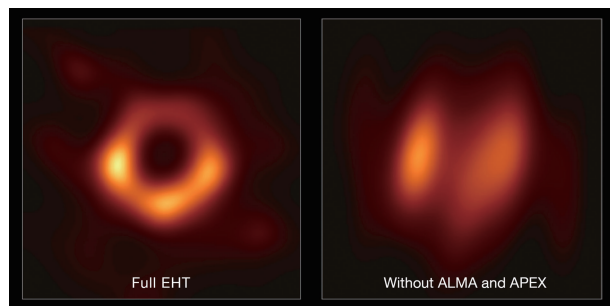

Fig. 34. Left: The first image of the shadow of the black hole in the center of M87 with the full array of the Event Horizon Telescope (including ALMA and APEX). Right: The image shows what the reconstruction would look like without the data from ALMA and APEX. The difference clearly shows the crucial role that ALMA played in the observations with a very large collecting area in the north-south baseline (Credit: EHT Collaboration).

global EHT collaboration. The VLBI mode was implemented to ALMA so that all ALMA antennas can be used as a single element of the global VLBI.

Although similar trials had been made several times before construction of ALMA, no one ever succeeded in imaging the black hole shadow due to the lack of sensitivity in short millimeter waves. With the participation of ALMA, EHT finally imaged the shadow of the black hole at the center of M87, a massive galaxy in the nearby Virgo galaxy cluster at the 55 million light-years distance (Fig. 34).

## 9. Conclusion

With the construction of the Nobeyama 45 m radio telescope and the NMA, the radio astronomy in Japan had reached world-class levels. Immediately after the completion of these telescopes, the Japanese radio astronomy community began studying the LMA project, developed it into the LMSA project with a special emphasis on the performance at submillimeter wavelengths, and further culminated in the international joint project ALMA.

Japan played an important role in the formulation of the ALMA's scientific goals, site selection and technological developments that made the goals possible. It was in starting the next plan just after the successful commissioning of the NRO that Japan would make a significant contribution to the success of the ALMA project. In this chapter, we summarize the results of the ALMA project and future issues for international joint projects.

**9.1. Results of ALMA international joint construction.** Regarding the three main perform-

ances (sensitivity, resolution, and wide frequency band) required for a telescope, it was possible to construct a telescope at the best site in the world which has higher performance compared to the individual plan alone. What made this possible was the aggregation of highly specialized knowledge from around the world and friendly competitions among engineers.

Since the commissioning of the initial science operation in 2011, ALMA has been revealing fine structure of invisible universe such as protoplanetary disks and distant galaxies deeply embedded in dusty clouds in the early universe, as well as the rich chemistry in interstellar space. ALMA also provided an essential contribution to the imaging of the black hole shadow. As of 2021, more than 2000 papers have already been published, and the ALMA observatory receives an average of 1800 observation proposals/year (oversubscription rate exceeding 4), showing the high interest of astronomers around the world.<sup>XVIII</sup>

ALMA is the first international joint project in the field of basic science promoted by the three parties of Japan, the United States and Europe on an equal footing, rather than being centered on the institutions of one host country. Since it is an international joint construction, it was necessary to clarify the equipment specifications, interface conditions and inspection procedures, and to introduce project management methods such as quality control, and it was essential to build a personnel system to implement them. Although this was the first experience for NAOJ and there were various difficulties in realizing it, NAOJ could overcome them and could contribute to realizing successful construction and operation. This was an important experience in promoting large-scale projects in the future. The East Asian team was able to hire talented staff, who worked as well as the North American and European groups, which led to the success of the project.

**9.2. Challenges in international joint construction.** In a multilateral project, it is very important to synchronize funding time schedules among participating partners to reduce the impact on project costs and schedules. Due to funding delays in Japan, NAOJ experienced various difficulties in project management. However, the Japanese team members worked extremely well and NAOJ was able

<sup>XVIII</sup> “The ALMA Cycle 8 2021 Proposal Process”, <https://almascience.nao.ac.jp/news/documents-and-tools/cycle8/cycle8-2021-proposal-process>.

to overcome this disadvantage without compromising the international credibility and visibility of the Japanese program. On the other hand, Japan's late entry into ALMA caused confusion in Europe and the United States, forcing a change in their plans. Japan, which caused a two-year budget delay despite the tripartite agreement, should take a hard look at this fact and reflect on it to prevent similar situations from occurring in future large-scale international projects.

Management is complicated compared to implementing in one country, so the overhead of decision making has increased. This led to an increase in cost and a longer construction period. In addition, although there was no withdrawal of a specific partner during the construction period, there is a risk that it may occur during the expected 30-year operation period.

The counterparts in the United States and European organizations that Japan deals with were high-level officials in NSF and ESO who have a strong influence on budget allocation. In contrast, Japan could not send high-level officials in the international negotiations, so that it was impossible to negotiate at an equal level with the U.S. and Europe. In October 2000, a representative of MESSC participated in the ALMA Coordination Committee meeting held in Paris and showed a strong intention of Japan's participation in ALMA. The United States and European sides took this fact seriously, and the subsequent discussions proceeded smoothly on the premise of participation of Japan to ALMA.

With the Japanese budget, it is difficult to approve the budget for research and development in advance for the implementation of large-scale projects, and it is difficult to participate in international cooperation at the research and development phase. In addition, the budget cannot include contingency to prepare for unexpected situations during project execution, which greatly limits the degree of freedom in planning adjustment in long-term plans.

In the United States and Europe, project managers have been established as professionals, and career paths have been made clear to become project managers for different projects based on their achievements in one project. In the field of astronomy in Japan, project managers have not been established as occupations. This is a big issue in planning future international joint projects. It is important to seek out and hire talented people for the project manager from a global perspective including recruiting from other fields in Japan. In that case, it is necessary to prepare employment conditions of international

standard and a comfortable working environment in Japan.

### Acknowledgements

Since the ALMA project has been accomplished through the efforts of a large number of individuals involved in Japan and in the world, we would like to refrain from naming individual names and expressing our gratitude. The authors, as one of those involved, feel very pleased to have contributed to the realization of the first international joint project in basic science in Japan, and would like to express our sincere gratitude to all those involved.

The authors would like to thank Dr. Paul Vanden Bout and Dr. Paul Ho for their critical reading of the manuscript and their valuable comments.

### References

- 1) Ishiguro, M., Orchiston, W., Akabane, K., Kaifu, N., Hayashi, M., Nakamura, T. *et al.* (2012) Highlighting the history of Japanese radio astronomy. 1: An introduction. *JAHH* **15**, 213–231.
- 2) Shimoda, K., Orchiston, W., Akabane, K. and Ishiguro, M. (2013) Highlighting the history of Japanese radio astronomy. 2: Koichi Shimoda and the 1948 solar eclipse. *JAHH* **16**, 98–106.
- 3) Oda, M. and Takakura, T. (1951) A study on the solar noise at 3300 m.c. *J. Phys. Soc. Jpn.* **6**, 202A.
- 4) Wendt, H., Orchiston, W., Ishiguro, M. and Nakamura, T. (2017) Highlighting the history of Japanese radio astronomy. 5: The 1950 Osaka solar grating array proposal. *JAHH* **20**, 112–118.
- 5) Tanaka, H. and Kakinuma, T. (1953) Equipment under construction for locating sources of solar noise at 4000 Mc/s. *Proc. Res. Inst. Atmos. Nagoya Univ.* **1**, 89.
- 6) Wendt, H., Orchiston, W. and Slee, B. (2008) W.N. Christiansen and the development of the solar grating array. *JAHH* **11**, 173–184.
- 7) Tanaka, H., Enome, S., Torii, C., Tsukiji, Y., Kobayashi, S., Ishiguro, M. *et al.* (1970) 3-cm radioheliograph. *Proc. Res. Inst. Atmos. Nagoya Univ.* **17**, 57–74.
- 8) Ishiguro, M., Tanaka, H., Enome, S., Torii, C., Tsukiji, Y., Kobayashi, S. *et al.* (1975) 8-cm radioheliograph. *Proc. Res. Inst. Atmos. Nagoya Univ.* **22**, 1–25.
- 9) Nakajima, H., Nishio, M., Enome, S., Shibasaki, K., Takano, T., Hanaoka, Y. *et al.* (1994) The Nobeyama Radioheliograph. *Proc. IEEE* **82**, 705–713.
- 10) Akabane, K. (1971) The millimeter wave telescope. *Astron. Her. (Astron. Soc. Jpn.)* **64**, 11–15 (in Japanese).
- 11) Akabane, K., Morimoto, M., Kaifu, N. and Ishiguro, M. (1983) The Nobeyama Radio Observatory. *Sky Telescope* **66**, 495–499.

- 12) Ishiguro, M., Morita, K.-I., Kasuga, T., Kanzawa, T., Iwashita, H., Chikada, Y. *et al.* (1985) The Nobeyama millimeter-wave interferometer. *In* Proceedings of International Symposium on Millimeter and Submillimeter Wave Radio Astronomy (Granada, 1984), pp. 75–84.
- 13) Wilson, R.W., Jefferts, K.B. and Penzias, A.A. (1970) Carbon monoxide in the Orion nebula. *ApJ* **161**, L43–L44.
- 14) Kamenno, S., Inoue, M., Matsumoto, K., Miyaji, T., Mikoshiba, H., Takaba, H. *et al.* (1995) Millimeter-wave spectra of compact steep-spectrum radio sources, and other 11 papers in “Recent Results from the Nobeyama 45 m Telescope”. *PASJ* **47**, 711–876.
- 15) Tutui, Y., Sofue, Y., Honma, M., Ichikawa, T. and Wakamatsu, K. (2001) Hubble constant at intermediate redshift using the CO-line tully-fisher relation, and other 8 papers in “Special Feature: Recent Results from the Nobeyama 45-m Telescope”. *PASJ* **53**, 701–832.
- 16) Nakai, N., Inoue, M. and Miyoshi, M. (1993) Extremely-high-velocity H<sub>2</sub>O maser emission in the galaxy NGC4258. *Nature* **361**, 45–47.
- 17) Okayasu, R., Ishiguro, M. and Tabara, H. (1992) Aperture synthesis observations of the radio luminous galaxy 3C 123 at 98 GHz, and other 12 papers in “Special Issue: Nobeyama Millimeter Array”. *PASJ* **44**, 335–480.
- 18) Scoville, N., Carlstrom, J., Padin, S., Sargent, A., Scott, S. and Woody, D. (1994) The Owens Valley Millimeter Array. *In* Astronomy with Millimeter and Submillimeter Wave Interferometry (eds. Ishiguro, M. and Welch, W.J.). ASP, San Francisco, ASP Conf. Ser., Vol. 59, pp. 10–17.
- 19) Welch, W.J., Thornton, D.D., Plambeck, R.L., Wright, M.C.H., Lugten, J., Urry, L. *et al.* (1996) The Berkeley-Illinois-Maryland-Association Millimeter Array. *PASP* **108**, 93–103.
- 20) Guilloteau, S., Delannoy, J., Downes, D., Greve, A., Guelin, M., Lucas, R. *et al.* (1992) The IRAM interferometer on Plateau de Bure. *A&A* **262**, 624–633.
- 21) Japan Radio Astronomy Forum. (1981) Nobeyama Symposium: System and operation of Nobeyama Radio Observatory. Vol. 110 (in Japanese).
- 22) Ishiguro, M., Kawabe, R., Nakai, N., Morita, K.I., Okumura, S.K. and Ohashi, N. (1994) The Large Millimeter Array. *In* Astronomy with Millimeter and Submillimeter Wave Interferometry, IAU Colloquium 140 (eds. Ishiguro, M. and Welch, W.J.). ASP, San Francisco, ASP Conf. Ser., Vol. 59, pp. 405–412.
- 23) Brown, R.L. (1994) The Millimeter Array. *In* Astronomy with Millimeter and Submillimeter Wave Interferometry, IAU Colloquium 140 (eds. Ishiguro, M. and Welch, W.J.). ASP, San Francisco, ASP Conf. Ser., Vol. 59, pp. 398–404.
- 24) Booth, R.S. (1994) A Southern Hemisphere Millimetre Array. *In* Astronomy with Millimeter and Submillimeter Wave Interferometry, IAU Colloquium 140 (eds. Ishiguro, M. and Welch, W.J.). ASP, San Francisco, ASP Conf. Ser., Vol. 59, pp. 413–418.
- 25) Handa, T., Hasegawa, T., Hayashi, M., Sakamoto, S., Oka, T. and Dame, T.M. (1992) A gradient of the CO  $J=2-1/J=1-0$  intensity ratio over the Galactic Plane. *AIP Conf. Proc.* **278**, 315–318.
- 26) Sekimoto, Y., Yamamoto, S., Oka, T., Ikeda, M., Maezawa, H., Ito, T. *et al.* (2000) The Mt. Fuji submillimeter-wave telescope. *Rev. Sci. Instrum.* **71**, 2895–2907.
- 27) Fukui, Y., Mizuno, N., Yamaguchi, R., Mizuno, A. and Onishi, T. (2001) On the mass spectrum of giant molecular clouds in the large magellanic cloud, and other 14 papers in “Special Feature: NANTEN 2”. *PASJ* **53**, L41–L49, 959–1118.
- 28) Takakuwa, S., Kamazaki, T., Saito, M., Yamaguchi, N. and Kohno, K. (2007) ASTE observations of warm gas in low-mass protostellar envelopes: Different kinematics between submillimeter and millimeter lines, and other 7 papers in “Special Feature: Initial Results from ASTE”. *PASJ* **59**, 1–72.
- 29) Asayama, S., Kamazaki, T., Ishii, S., Ito, T., Fujii, Y., Iono, D. *et al.* (2022) ASTE Band 10 (787–950 GHz) Heterodyne Receiver: System Description, Commissioning and Science Verification. *PASJ* **74**, 678–688.
- 30) Ishiguro, M. and Welch, W.J. eds. (1994) Astronomy with Millimeter and Submillimeter Wave Interferometry, IAU Colloquium 140. ASP, San Francisco, ASP Conf. Ser., Vol. 59.
- 31) National Research Council and Astronomy and Astrophysics Survey Committee. (1991) The Decade of Discovery in Astronomy and Astrophysics. National Academies Press, Washington, D.C.
- 32) Brown, R.L. and Vanden Bout, P.A. (1991) CO emission at  $z=2.2867$  in the galaxy IRAS F10214+ 4724. *AJ* **102**, 1956–1959.
- 33) Shaver, P.A. and Booth, R.S. (1998) The Large Southern Array. *Messenger* **91**, 26–28.
- 34) Ishiguro, M. (1994) Status report of LMSA project. *In* Proceedings of the 12th NRO Users Meeting (Nobeyama, 1994), pp. 91–97 (in Japanese).
- 35) Brown, R.L. (1994) The Millimeter Array NRAO. *NRAO Newsletter* **61**, 11.
- 36) Evans, N. (1996) Report of the millimeter array science workshop. *NRAO Newsletter* **66**, 9–10.
- 37) Ishiguro, M. and Kawabe, R. eds. (1997) Millimeter and Submillimeter Astronomy at 10 Milli-arcseconds Resolution. *NRO Report*, Vol. 430.
- 38) Madsen, C. (2012) The Jewel on the Mountaintop: The European Southern Observatory through Fifty Years. Wiley-VCH, Weinheim, pp. 375–376.
- 39) ESO (1997) Governing Bodies. *In* ESO Annual Report 1997. ESO, München, p. 65.
- 40) Radford, S. (1998) International LMSA/LSA/MMA Site Testing Workshop. *NRAO Newsletter* **75**, 4.
- 41) Brown, R.L. (1999) Evolution of the MMA to ALMA. *NRAO Newsletter* **80**, 1–2.
- 42) Hasegawa, T. (2000) Japan’s Participation Expected by the World. *Astron. Her. (Astron. Soc. Jpn.)* **93**, 690–691 (in Japanese).

- 43) Rafal, M.D. (2001) ALMA Japan announces intent to join ALMA. NRAO Newsletter **86**, 1–2.
- 44) Rafal, M.D. (2002) ALMA. NRAO Newsletter **90**, 2.
- 45) Lo, K.Y. (2006) From the Director. NRAO Newsletter **108**, 1.
- 46) Rykaczewski, H. (2008) Organization and management of the ALMA project. Proc. SPIE **7017**, 70170G.
- 47) Kaifu, N. (2015) The IAU today and the Asian-Pacific region. PKAS **30**, 39–43.
- 48) Ishiguro, M., the LMSA Working Group (1998) Japanese Large Millimeter and Submillimeter Array. Proc. SPIE **3357**, 244–253.
- 49) Kono, K., Kawabe, R., Ishiguro, M., Kato, T., Otarola, A., Booth, R. *et al.* (1994) Preliminary result of site testing in northern Chile with a portable 220 GHz radiometer. LMSA Memo 1995-001 (also NROTR 42).
- 50) Ishiguro, M., Kanzawa, T. and Kasuga, T. (1990) Monitoring of atmospheric phase fluctuations using geostationary satellite signals. In URSI/IAU Symposium on Radio Astronomical Seeing (Beijing, 1989) (eds. Baldwin, J.E. and Shouguan, W.). Pergamon Press, Oxford, pp. 60–63.
- 51) Radford, S.J. and Peterson, J.B. (2016) Submillimeter atmospheric transparency at Maunakea, at the south pole, and at Chajnantor. PASP **128**, 075001.
- 52) Otarola, A., Delgado, G., Booth, R., Belitsky, V., Urbain, D., Radford, S. *et al.* (1998) European site testing at Chajnantor: a step towards the Large Southern Array. Messenger **94**, 13–20.
- 53) Hirota, T., Yamamoto, S., Sekimoto, Y., Kohno, K., Nakai, N. and Kawabe, R. (1998) Measurements of the 492 GHz atmospheric opacity at Pampa la Bola and Rio Frio in northern Chile. PASJ **50**, 155–162.
- 54) Matsuo, H., Sakamoto, A. and Matsushita, S. (1998) FTS measurements of submillimeter-wave atmospheric opacity at Pampa la Bola. PASJ **50**, 359–366.
- 55) Matsushita, S., Matsuo, H., Pardo, J.R. and Radford, S.J. (1999) FTS measurements of submillimeter-wave atmospheric opacity at Pampa la Bola II: Supra-terahertz windows and model fitting. PASJ **51**, 603–610.
- 56) Holdaway, M.A. and Radford, S.J.E. (1998) Options for placement of a second site test interferometer on Chajnantor. ALMA Memo 196.
- 57) Otarola, A., Hofstadt, D., Radford, S.J.E. and Sakamoto, S. (2002) Physical parameters of the Chajnantor science preserve. ALMA Memo 413.
- 58) Holdaway, M.A., Ishiguro, M., Foster, S.M., Kawabe, R., Kohno, K., Owen, F.N. *et al.* (1996) Comparison of Rio Frio and Chajnantor site testing data. LMSA Memo 1996-003 (also NROTR 51).
- 59) Sakamoto, S., Handa, K., Kohno, K., Nakai, N., Otarola, A., Radford, S.J.E. *et al.* (2000) Comparison of meteorological data at the Pampa La Bola and Llano de Chajnantor sites. ALMA Memo 322 (also LMSA Memo 2000-008).
- 60) Radford, S.J.E., Butler, B.J., Sakamoto, S. and Kohno, K. (2001) Atmospheric transparency at Chajnantor and Pampa la Bola. ALMA Memo 384.
- 61) Butler, B.J., Radford, S.J.E., Sakamoto, S. and Kohno, K. (2001) Atmospheric phase stability at Chajnantor and Pampa la Bola. ALMA Memo 365.
- 62) Sakamoto, S., Ishizaki, H. and Kohno, K. (2004) Wind power spectrum near Chajnantor. ALMA Memo 500.
- 63) Rojas, L. (2000) Geotechnical study, Chajnantor site, II Region. ALMA Memo 408 (also LMSA Memo 2000-004).
- 64) Snyder, L.A., Radford, S.J.E. and Holdaway, M.A. (2000) Underground temperature fluctuations and water drainage at Chajnantor. ALMA Memo 314.
- 65) Sakamoto, S. (2001) Seasonal and diurnal variation of upper soil resistivity in the Cerro Chascon science preserve. ALMA Memo 369.
- 66) Sakamoto, S., Ezawa, H., Takahashi, T. and Yamaguchi, N. (2000) Vertical profiles of soil resistivity at Pampa La Bola and Llano de Chajnantor locations. ALMA Memo 326.
- 67) Sakamoto, S. and Sekiguchi, T. (2001) Spatial distribution of near-surface soil resistivity in the Cerro Chascon science preserve. ALMA Memo 346.
- 68) Sakamoto, S. (2003) UV intensity near AOS and OSF. ALMA Memo 448.
- 69) Sakamoto, S. (2006) Reference values of arterial oxygen saturation and heart rate at the ALMA site. ALMA Memo 549.
- 70) Wootten, A. and Thompson, A.R. (2009) The Atacama large millimeter/submillimeter array. Proc. IEEE **97**, 1463–1471.
- 71) Morita, K.I. and Holdaway, M.A. (2008) The array configuration design of the Atacama Compact Array. Proc. SPIE **7012**, 257–268.
- 72) Iguchi, S., Morita, K.I., Sugimoto, M., Vilaró, B.V., Saito, M., Hasegawa, T. *et al.* (2009) The Atacama Compact Array (ACA). PASJ **61**, 1–12.
- 73) Ezawa, H., Ishiguro, M., Matsuo, H., Miyawaki, K., Satou, N. and Ukita, N. (2000) Development of the reflector panel for the new 10-m millimeter/submillimeter telescope. Proc. SPIE **4015**, 515–522.
- 74) Ezawa, H., Kawabe, R., Kohno, K. and Yamamoto, S. (2004) The Atacama submillimeter telescope experiment (ASTE). Proc. SPIE **5489**, 763–772.
- 75) Takaki, J., Kawaguchi, N. and Oshima, T. (2010) Primary mirror performance of ALMA antenna. J. Jpn. Soc. Infrared Sci. Tech. **19**, 21–24 (in Japanese with English abstract).
- 76) Mangum, J.G., Baars, J.W., Greve, A., Lucas, R., Snel, R.C., Wallace, P. *et al.* (2006) Evaluation of the ALMA prototype antennas. PASP **118**, 1257–1301.
- 77) Greve, A. and Mangum, J. (2008) Mechanical measurements of the ALMA prototype antennas. IEEE Antennas Propag. Mag. **50**, 66–80.
- 78) Ukita, N., Saito, M., Ezawa, H., Ikenoue, B.,

- Ishizaki, H., Iwashita, H. *et al.* (2004) Design and performance of the ALMA-J prototype antenna. *Proc. SPIE* **5489**, 1085–1093.
- 79) Inatani, J. and Kaifu, N. (1989) Radio astronomy in millimetre waves and beyond—Nobeyama Radio Observatory and its receiver development. *In* 1989 19th European Microwave Conference, London, 1989. IEEE, pp. 128–135.
- 80) Inatani, J., Kasuga, T., Kawabe, R., Tsuboi, M., Sakamoto, A., Yamamoto, M. *et al.* (1990) SIS receiver development at Nobeyama Radio Observatory. *In* Submillimetre Astronomy. Proceedings of the Kona Symposium on Millimeter and Submillimetre Astronomy, Held at Kona, Hawaii, October 3–6, 1988 (eds. Watt, G.D. and Webster, A.S.). Springer, Dordrecht, pp. 73–74.
- 81) Noguchi, T., Shi, S.C. and Inatani, J. (1995) Parallel connected twin SIS junctions for millimeter and submillimeter wave mixers: analysis and experimental verification. *IEICE Trans. Electron.* **78**, 481–489.
- 82) Shi, S.C., Noguchi, T. and Inatani, J. (1997) Development of a 500-GHz band SIS mixer. *IEEE Trans. Appl. Supercond.* **7**, 2587–2590.
- 83) Asayama, S.I., Takahashi, T., Kubo, K., Ito, T., Inata, M., Suzuki, T. *et al.* (2014) Development of ALMA Band 4 (125–163 GHz) receiver. *PASJ* **66**, 57.
- 84) Kimura, K., Iwashita, H., Asayama, S.I., Sugimoto, M., Kikuchi, G. and Ogawa, H. (2008) Antenna performance of a directly dug corrugated feedhorn for the 150-GHz band. *Int. J. Infrared Millim. Waves* **29**, 713–723.
- 85) Asayama, S.I. and Kamikura, M. (2009) Development of double-ridged waveguide orthomode transducer for the 2 MM band. *J. Infrared Millim. Terahertz Waves* **30**, 573–579.
- 86) Sekimoto, Y., Iizuka, Y., Satou, N., Ito, T., Kumagai, K., Kamikura, M. *et al.* (2008) Development of ALMA Band 8 (385–500 GHz) Cartridge. *In* Proceedings of 19th International Symposium on Space Terahertz Technology, Groningen. pp. 253–257.
- 87) Uzawa, Y., Fujii, Y., Gonzalez, A., Kaneko, K., Kroug, M., Kojima, T. *et al.* (2013) Development and testing of Band 10 receivers for the ALMA project. *Physica C: Superconduct.* **494**, 189–194.
- 88) Ueda, A., Noguchi, T., Iwashita, H., Sekimoto, Y., Ishiguro, M., Takano, S. *et al.* (2003) W-band waveguide photomixer using a uni-traveling-carrier photodiode with 2-mW output. *IEEE Trans. Microwave Theory Tech.* **51**, 1455–1459.
- 89) Takano, S., Ueda, A., Yamamoto, T., Asayama, S., Sekimoto, Y., Noguchi, T. *et al.* (2003) The first radio astronomical observation with photonic local oscillator. *PASJ* **55**, L53–L56.
- 90) Nakashima, N. and Ikeya, Y. (2010) Technology of 4K-GM cryocooler for ALMA receiver. *J. Jpn. Soc. Infrared Sci. Tech.* **19**, 25–28 (in Japanese with English abstract).
- 91) Thompson, A.R., Moran, J.M. and Swenson, G.W. (2017) *Interferometry and Synthesis in Radio Astronomy*. Springer Nature, Cham.
- 92) Chikada, Y., Ishiguro, M., Hirabayashi, H., Morimoto, M., Morita, K., Kanzawa, T. *et al.* (1987) A  $6 \times 320$ -MHz 1024-channel FFT cross-spectrum analyzer for radio astronomy. *Proc. IEEE* **75**, 1203–1210.
- 93) Kamazaki, T., Okumura, S.K., Chikada, Y., Okuda, T., Kurono, Y., Iguchi, S. *et al.* (2012) Digital spectro-correlator system for the Atacama Compact Array of the Atacama Large Millimeter/submillimeter Array. *PASJ* **64**, 29.
- 94) Okumura, S.K., Iguchi, S., Chikada, Y., Momose, M. and Okiura, M. (2002) First astronomical fringe of a test correlator for the ALMA: Simultaneous achievement of wideband and high resolution. *PASJ* **54**, L59–L62.
- 95) Kosugi, G. (2012) Extensive data handling for ALMA (Atacama Large Millimeter/Submillimeter Array). *JAXA Res. Dev. Rep.* **JAXA-RR-11-007**, 77–81 (in Japanese with English abstract).
- 96) ALMA Partnership, Fomalont, E.B., Vlahakis, C., Corder, S., Remijan, A., Barkats, D., Lucas, R. *et al.* (2015) The 2014 ALMA long baseline campaign: An overview. *ApJ* **808**, L1.
- 97) ALMA Partnership, Brogan, C.L., Pérez, L.M., Hunter, T.R., Dent, W.R.F., Hales, A.S., Hills, R.E. *et al.* (2015) The 2014 ALMA long baseline campaign: First results from high angular resolution observations toward the HL Tau region. *ApJ* **808**, L3.
- 98) ALMA Partnership, Vlahakis, C., Hunter, T.R., Hodge, J.A., Pérez, L.M., Andreani, P., Brogan, C.L. *et al.* (2015) The 2014 ALMA long baseline campaign: Observations of the strongly lensed submillimeter galaxy HATLAS J090311.6+003906 at  $z = 3.042$ . *ApJ* **808**, L4.
- 99) McGuire, B.A., Brogan, C.L., Hunter, T.R., Remijan, A.J., Blake, G.A., Burkhardt, A.M. *et al.* (2018) First results of an ALMA Band 10 spectral line survey of NGC 6334I: Detections of glycolaldehyde (HC(O)CH<sub>2</sub>OH) and a new compact bipolar outflow in HDO and CS. *ApJ* **863**, L35.
- 100) Event Horizon Telescope Collaboration, Akiyama, K., Alberdi, A., Alef, W., Asada, K., Azulay, R., Bacsko, A.-K. *et al.* (2019) First M87 Event Horizon Telescope results. I. The shadow of the supermassive black hole. *ApJ* **875**, L1.

(Received May 30, 2022; accepted July 5, 2022)

## Profile

Masato Ishiguro was born in Gifu Prefecture, Japan in 1945 and graduated from the Department of Electronic Engineering, Nagoya University in 1968. He entered the doctoral program of the Graduate School of Engineering at the same University, leaving after one year, while becoming a research associate at the Research Institute of Atmospheric of Nagoya University in 1970. Thereafter, he started his research on radio interferometry techniques and received a Ph.D. degree on radio astronomy from the University of Tokyo in 1980. In 1980, he became an associate professor at the University of Tokyo and moved to the Tokyo Astronomical Observatory to join the project of constructing large millimeter-wave telescopes at the Nobeyama Radio Observatory (NRO), where he was in charge of constructing the Nobeyama Millimeter Array. From 1990 to 1996, he served as Director of the Observatory. While working at NRO, he led the planning of the large array at millimeter and submillimeter wavelengths. Since 1998, he has served as ALMA-Japan Project Director of the Atacama Large Millimeter/submillimeter Array (ALMA). He was a professor of National Astronomical Observatory of Japan (NAOJ) from 1988 to 2009. In 2007, he stepped down from being the Director and spent 16 months in Chile as a lead test scientist at the forefront of ALMA construction. In 2013, he was awarded a Commendation from the Minister of Education, Culture, Sports, Science and Technology for his outstanding research on aperture synthesis radio telescope. He is currently Professor Emeritus of NAOJ and a Member of the International Astronomical Union (IAU).

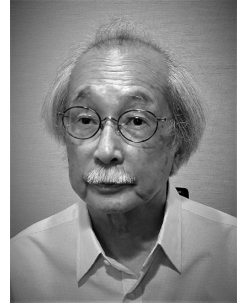

## Profile

Kurazo Chiba was born in Tokyo in 1951 and graduated from Gunma National College of Technology in 1972. From 1972 to 77, he worked for a computer manufacturer, and was engaged in the development of software for large general-purpose computers. In 1977, he moved to the Institute for Nuclear Study, the University of Tokyo and developed data-processing systems for accelerator experiments, and further constructed and operated computer networks for academic use. In 1997, he transferred to the National Astronomical Observatory of Japan (NAOJ) and joined the ALMA project in 2001, where he contributed as project controller of the ALMA Japanese team. After retirement from NAOJ in 2016, he started research in the history of science. He received his M.A. degree from Tokyo Institute of Technology in 2019. He is currently pursuing a doctoral program at the same university.



## Profile

Seiichi Sakamoto was born in Tokyo in 1965 and graduated from Department of Astronomy, the University of Tokyo in 1989. He received his Ph.D. degree on radio astronomy from the same university in 1994. After working as a JSPS Research Fellow at the University of Tokyo and a COE Researcher at National Astronomical Observatory of Japan (NAOJ), he was hired by NAOJ as an assistant professor in 1997 and joined the Large Millimeter and Submillimeter Array (LMSA) promotion office as one of the initial members. He was later promoted to an associate professor in 2002. In 2007, he became a professor at Institute of Space and Astronautical Science (ISAS), JAXA, and was appointed to be as Director for Education and Public Outreach. In 2014, he moved to NAOJ and joined the ALMA project, where he contributed as Director of NAOJ Chile Observatory (2016–2018) and as Head of the East Asian Integrated Engineering Team. He has also been a professor at the University of Tokyo since 2016. He is a Member of the International Astronomical Union (IAU).

