

Maturation of the Catalytic α -Subunit of Na,K-ATPase during Intracellular Transport

Kathi Geering,* Jean-Pierre Kraehenbuhl,† and Bernard C. Rossier*

*Institute of Pharmacology, University of Lausanne, CH-1005 Lausanne, Switzerland; and †Institute of Biochemistry, University of Lausanne and Swiss Institute for Experimental Cancer Research, CH-1066 Epalinges, Switzerland

Abstract. The protease sensitivity of the catalytic α -subunit of Na,K-ATPase during intracellular transport along the exocytic pathway has been investigated in two amphibian epithelial cell lines. Controlled trypsinolysis followed by immunoprecipitation of cell homogenates or microsomal fractions from [³⁵S]methionine pulse-chased A6 kidney cells revealed distinct cleavage patterns by SDS-PAGE. Shortly after synthesis (7-min pulse), the 98-kD α -subunit is fully sensitive to trypsin digestion and is cleaved into a 35-kD membrane-bound and a 27.5-kD soluble peptide. With a 15-min pulse, 10% of the newly synthesized polypeptide becomes resistant to trypsin digestion. With

longer chase time, the proportion of protease-resistant α -subunit further increases. Concomitantly, the α -subunit acquires the ability to undergo cation-dependent conformational transitions, as reflected by distinct tryptic digest patterns in the presence of Na⁺ or K⁺. Similar results were obtained in TBM cells, a toad bladder cell line. Our data indicate that the catalytic subunit of Na,K-ATPase is structurally rearranged during intracellular transport from its site of synthesis to its site of action at the cell surface, a modification which might mark the functional maturation of the enzyme.

THE plasma membrane enzyme Na,K-ATPase plays an essential role in the establishment and maintenance of cellular homeostasis and, in addition, participates as the major driving force in net transepithelial Na⁺ reabsorption (for review see reference 19). The transport characteristics of the enzyme have been studied mainly with intact red blood cells, while its biochemical properties have been established using purified enzyme preparations. More recently, the structure-function relationship of the enzyme has been analyzed in reconstituted preparations (for review see references 1 and 2) or in microsomal vesicles from renal outer medulla (9). Using monoclonal or polyclonal antibodies directed against α - or β -subunits, it has become possible to study the biosynthesis of the enzyme (3-8, 12, 16), its hormonal regulation (10, 11, 15), and its cellular localization (21, 29).

Both enzyme subunits are cotranslationally and independently inserted into microsomal membranes (12). Little is known of the mechanisms involved in the intracellular routing of the enzyme and on its functional maturation during transport from its site of synthesis to its site of action in the plasma membrane. The two subunits rapidly associate with each other and form a complex which can be recovered by immunoprecipitation (30). The kinetics of transport of the β -subunit from the rough endoplasmic reticulum (RER)¹ to

the Golgi region have been determined based on the acquisition of endoglycosidase H resistance (13, 32), while the transport of the α -subunit from the RER to the plasma membrane has been examined in MDCK cells with a photoactivatable inhibitor of the Na,K pump, N-azido benzoyl-ouabain, and anti-ouabain antibodies (3). Using the same probes, Caplan et al. (4) have demonstrated that the α -subunit does not acquire all of its biochemical functions until at least 10 min after completion of synthesis. In this study, we have followed the processing and maturation of Na,K-ATPase in amphibian kidney and bladder cell lines by analyzing the protease sensitivity of α -subunits immunoprecipitated from [³⁵S]methionine pulse-chased cells. We show that the α -subunit undergoes structural reorganization early during intracellular transport, which is paralleled by the capacity to undergo cation-dependent changes in conformation, a property which is characteristic of the mature Na,K pump (17-19).

Materials and Methods

Cell Lines

A6 cells (derived from the kidney of *Xenopus laevis*) and TBM cells (derived from the urinary bladder of *Bufo marinus*) have been obtained from J. S. Handler, National Institutes of Health, (Bethesda, MD [TBM and A6]) or from the American Cell Culture Type Collection (Rockville, MD; A6). The cells were cultivated according to Handler (13).

1. *Abbreviations used in this paper:* DOC, deoxycholate; RER, rough endoplasmic reticulum.

Biosynthetic Labeling of A6 and TBM Cells

Cells (grown on 63-cm² petri dishes) were labeled at confluency with L-[³⁵S]methionine (Amersham International, Buckinghamshire, England; sp act >1,000 μCi/mmol) in 5 ml of tissue culture HAM medium (16) without serum and without methionine for different time periods at 28°C. Two labeling protocols were used: (a) 7-min pulse with 400 μCi/ml L-[³⁵S]methionine, followed or not by a 20-min or a 3-h chase with HAM medium containing 1 mM methionine and 20 μg/ml of cycloheximide; (b) 15-, 30-min, or 3-h pulse with 250 μCi/ml L-[³⁵S]methionine. Incorporation of labeled precursor was stopped on ice by addition of 7 ml of HAM containing methionine and cycloheximide.

Cell Homogenization

The cells were scraped off the petri dishes with a rubber policeman, washed twice in HAM, and once in an homogenization buffer containing 30 mM DL-histidine, 5 mM EDTA, 200 mM sucrose, and 10 mM Tris-HCl, pH 7.4. The cells (3×10^7) were suspended in 0.6 ml of homogenization buffer containing 0.1 mg/ml DNase I (type I; Sigma Chemical Co., St. Louis, MO) and sonicated on ice three times for 3 s using a sonifier (Branson Sonic Power Co., Danbury, CT; position 4).

Controlled Proteolysis

Protease treatment was carried out in homogenization buffer containing either 140 mM Na acetate or 140 mM K acetate. The trypsin/protein ratio varied between 0.05 and 0.2 (trypsin type XI; Sigma Chemical Co., St. Louis, MO). Proteolysis was carried out in the presence or absence of deoxycholate (DOC) with a detergent/protein ratio of between 0.14 and 0.2. Controlled trypsinolysis was performed on (a) cell homogenates which were assayed directly or subjected to centrifugation at 180,000 g for 20 min in an airfuge (Beckman Instruments, Inc., Palo Alto, CA) with a resulting P1 pellet and S1 supernatant; and on (b) a crude microsomal pellet (P1) obtained after centrifugation of the homogenate for 20 min at 180,000 g. Trypsinolysis was stopped with a fivefold excess (wt/wt) of soybean trypsin inhibitor (Sigma Chemical Co.) and the mixture was left for 10 min on ice. Samples were adjusted to 3.7% SDS. Aliquots were precipitated with 10% TCA, and protein content (24) and radioactivity were determined in the pellet after solubilization with 1 N NaOH.

Immunoprecipitation

Immunoprecipitation of α-subunit from A6 or TBM cells was performed with antibodies prepared against purified α-subunit from the kidney of *Bufo marinus* (13). Immunoprecipitation of β-subunit from A6 cells was performed with antibodies against purified β-subunit from the kidney of *Xenopus laevis* (12). Immunoprecipitation, SDS-PAGE, detection by autoradiography, and quantification of the subunits were carried out as previously described (11, 12).

Results

Protease Sensitivity of the α-Subunit of Na,K-ATPase during Intracellular Transport

Kinetics of Transport of the α-Subunit. The absence of posttranslational modifications of the α-subunit of Na,K-ATPase, as reflected by lack of changes in the relative mobility of the polypeptide, is documented in a typical pulse-chase experiment illustrated in Fig. 1 (lanes 1-3). In contrast, the β-subunit undergoes N-linked glycosylation and the core, trimmed-, and terminally glycosylated forms can be resolved on SDS-PAGE in A6 cells (Fig. 1, lanes 4-6). The kinetics of transport from the RER to the *cis* and *trans* Golgi region have been established by following the acquisition of endo-β-N-acetyl-glucosaminidase H (endo H) resistance (12, 30) or with specific inhibitors of glycosylation (Zamofing, D., B. C. Rossier, and K. Geering, manuscript in preparation). Since the α- and β-subunits are rapidly associated after synthesis and form a complex which can be recovered by immunoprecipitation with antibodies directed

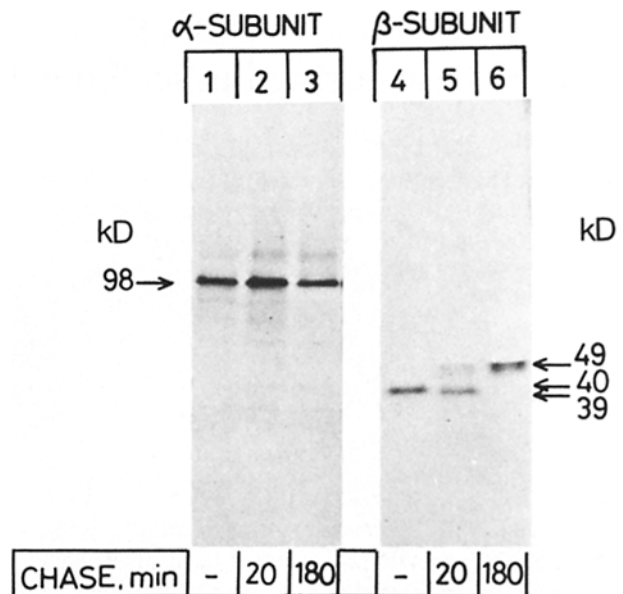
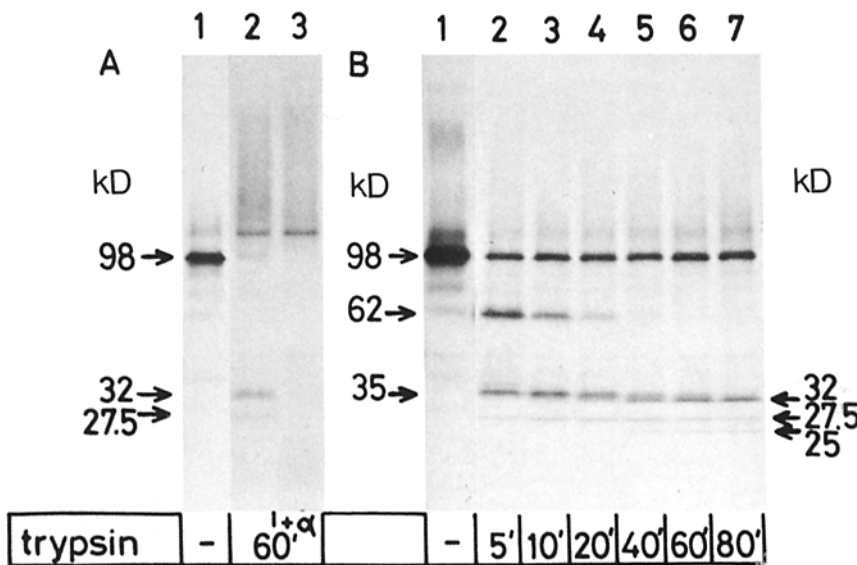

Figure 1. Processing of α- and β-subunits of Na,K-ATPase during intracellular transport in A6 cells. A6 cells were pulsed for 7 min (lanes 1-6) with [³⁵S]methionine and chased for 20 min (lanes 2 and 5) or 3 h (lanes 3 and 6). Cell homogenates were immunoprecipitated with anti-α-subunit (lanes 1-3) or anti-β-subunit serum (lanes 4-6) and processed as described in Materials and Methods. Molecular masses were determined using proteins with known molecular mass as references (i.e., 98 kD).

against each separate subunit (30; Verrey, F., P. Kairouz, E. Schaerer, P. Fuentes, K. Geering, B. C. Rossier, and J. P. Kraehenbuhl, manuscript in preparation), one might expect that the kinetics of intracellular transport would be the same for the two subunits. Based on the glycosylation pattern of the β-subunit from A6 cells, we have operationally defined three compartments along the secretory pathway corresponding to the time points selected in the pulse-chase protocol. In the early compartment (7-min pulse), the β-subunit is in its core-glycosylated endo H-resistant form (40 kD) (Fig. 1, lane 4) and is likely to be restricted to the RER. In the intermediate compartment (after a 20-min chase), some β-subunit is terminally glycosylated (49 kD), but most is in a trimmed form (39 kD) (Fig. 1, lane 5); hence, the bulk of the glycoprotein has reached the medial elements of the Golgi complex (23). In the late compartment (180-min chase), all β-subunit is terminally glycosylated (49 kD), and therefore has passed through the *trans* elements of the Golgi complex (23).

Trypsin Sensitivity of the α-Subunit

In the Early Compartment. A6 cells were pulsed for 7 min with [³⁵S]methionine and a crude microsomal fraction was subjected to controlled trypsinolysis before immunoprecipitation with anti-α subunit serum. Most of the 98-kD α-subunit was digested by trypsin (60 min on ice), with the appearance of two fragments of 32 and 27.5 kD (Fig. 2 A, lanes 1 and 2; Fig. 3 A). All of the immunoprecipitated material, with the exception of a 120-kD band occasionally observed in short pulses, showed competition with an excess of purified α-subunit during immunoprecipitation indicating that the 32- and 27.5-kD tryptic products are indeed derived



from the 98-kD α -subunit of Na,K-ATPase (Fig. 2 A, lane 3). With a longer pulse (15 min), already 10% of the α -subunit became resistant to proteolysis (Fig. 2 B, lanes 1-6). A time course of trypsinolysis was performed on homogenates of A6 cells pulsed for 15 min to more precisely define the trypsin sensitivity of the α -subunit. After 5 min, tryptic fragments of 62, 35, and 27.5 kD, were generated (Fig. 2 B, lane 2). With increasing time of proteolysis (up to 80 min), the tryptic fragments were progressively cleaved into smaller peptides of 32, 27.5, and 25 kD. The conversion of the 35-kD peptide into a 32-kD fragment followed the same time course as that of the 98-kD α -subunit into a 95-kD fragment, visible in less exposed fluorograms. This suggests that the 3-kD shift of the two polypeptides might involve the same tryptic site,

which in both the mammalian (6) and the amphibian (Verrey, F., P. Kairouz, E. Shaerer, P. Fuentes, K. Geering, B. C. Rossier, and J. P. Kraehenbuhl, manuscript in preparation) α -subunit lies close to its NH₂ terminus. In all subsequent experiments, homogenates or microsomes were treated with trypsin for 60 min.

In the Intermediate Compartment. Microsomal fractions of A6 cells pulsed for 7 min and chased for 20 min were treated with trypsin and immunoprecipitated with anti- α -subunit antibodies. In the intermediate compartment, there was a drastic increase in the protease resistance of the α -subunit. About 20% of the total immunoprecipitated material was recovered as a 98-kD polypeptide and more than 40% as a 95-kD fragment (Fig. 3 A).

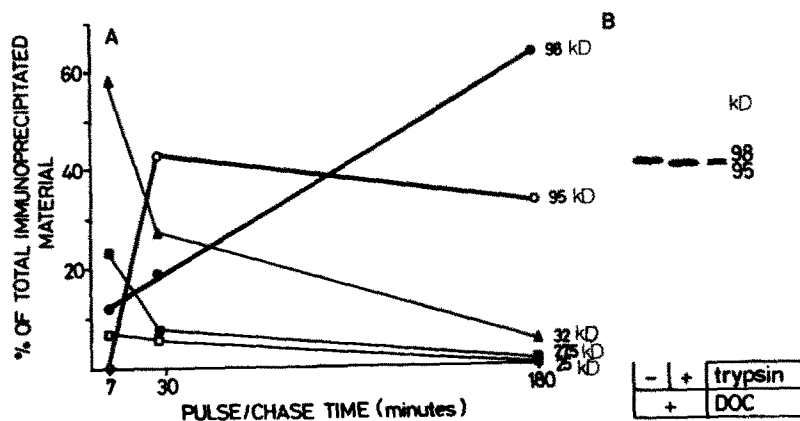

of the various polypeptides of the total α -subunit-related material immunoprecipitated by the anti- α serum after each pulse and/or pulse-chase period. (B) Effect of detergent on tryptic fragmentation of the protease-resistant α -subunit. A microsomal fraction obtained from cells pulse-labeled for 22 h was incubated for 60 min at 0°C in the presence of 140 mM Na acetate and DOC (detergent/protein ratio: 0.14) with or without trypsin (trypsin/protein ratio: 0.05), and further processed as described in Materials and Methods. Immunoprecipitation was performed with 250 μ g of cellular proteins of the control and trypsinized sample.

Figure 2. Controlled trypsinolysis of α -subunit from A6 cells. (A) Trypsinolysis of α -subunit from cells labeled for 7 min with [35 S]methionine. Aliquots of microsomal fractions, prepared as described in Materials and Methods, were incubated for 60 min at 0°C in the presence of 140 mM Na acetate without (lane 1) or with (lanes 2 and 3) trypsin at a trypsin/protein ratio of 0.05. Proteolysis was stopped with a fivefold excess (wt/wt) of soybean trypsin inhibitor. Samples (250 μ g protein) were immunoprecipitated with anti- α -serum in the absence (lanes 1 and 2) or presence (lane 3) of 40 μ g of purified α -subunit, resolved on SDS-PAGE, and revealed by autoradiography as described in Materials and Methods. (B) Time course of proteolysis of α -subunit. Aliquots of cell homogenates of A6 cells, labeled for 15 min with [35 S]methionine were incubated at 0°C in the presence of 140 mM Na acetate for 60 min without trypsin (lane 1) or with trypsin (trypsin/protein ratio 0.05) (lanes 2-7) for indicated times (in minutes). Samples (250 μ g protein) were immunoprecipitated and revealed by autoradiography as described in Materials and Methods.

Figure 3. Trypsin sensitivity of α -subunit of Na,K-ATPase during intracellular transport. (A) Tryptic fragmentation of α -subunit residing in an early (7-min pulse), intermediate (20-min chase), and late (180-min chase) compartment as defined in Results. A6 cells were pulse-labeled with [35 S]methionine for 7 min followed or not by a 20-min or a 180-min chase as described in Materials and Methods. Crude microsomal pellets were prepared (see Materials and Methods) and treated with a trypsin/protein ratio of 0.05 at 0°C for 60 min in the presence of 140 mM Na acetate, and further processed as described in Materials and Methods. The immunoprecipitated α -subunit and its proteolytic fragments were quantitated on autoradiograms by laser densitometry (Ultrascan, LKB Instruments, Inc.). Shown is the percentage

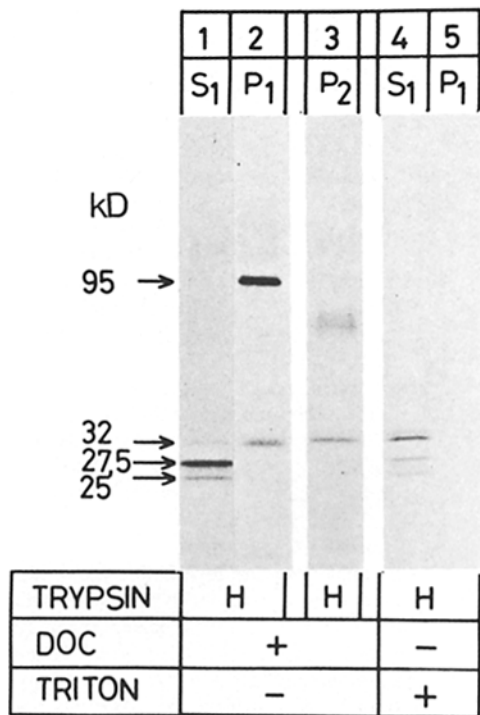

Figure 4. Membrane association of α -subunit tryptic fragments. Cell homogenates (*H*) of A6 cells, labeled for 30 min with [³⁵S]methionine, were incubated for 60 min at 0°C with trypsin at a trypsin/protein ratio of 0.05 in the presence of DOC, at a detergent/protein ratio of 0.14 (lanes 1-3), or in the presence of 1% Triton X-100 (lanes 4 and 5). The homogenates (*H*) were then centrifuged at 180,000 *g* for 20 min and the resulting supernatants (S₁) and pellets (P₁) were immunoprecipitated with anti- α -subunit serum. In one instance, the S₁ supernatant was recentrifuged at 300,000 *g* for 120 min and the pellet (P₂) was immunoprecipitated (lane 3).

In the Late Compartment. With increasing chase time (180 min), the resistance to trypsin digestion of the α -subunit further increased so that more than 95% of the total immunoprecipitated material was recovered as 98- and 95-kD polypeptides in a 2:1 ratio (Fig. 3 A). The appearance of totally resistant α -subunit (98-kD) in the late compartment could be explained by the formation of right side out vesicles generated from the plasma membrane by the homogenization procedure, which prevents access of trypsin to the 3-kD (NH₂-terminal) cleavage site. This is supported by experiments in which trypsin was added during homogenization (data not shown) or when low concentrations of DOC (detergent/protein ratio of 0.14) were present during trypsinolysis (Fig. 3 B). Under such conditions, the 98-kD α -subunit was converted into the 95-kD fragment. The quantitation shown in Fig. 3 A, which summarizes changes in protease resistance of the α -subunit during intracellular routing, remains relative, because the different tryptic fragments generated from the α -subunit are not recognized with the same efficiency by the polyclonal anti- α -subunit antibodies (32).

Membrane Topology of the α -Subunit during Intracellular Transport

In the early compartment, most of the α -subunit was cleaved into two main fragments, a 32- and a 27.5-kD peptide. Only the 32-kD peptide was associated with the membrane as shown in Fig. 4. In this experiment, trypsinolysis was performed on a cell homogenate followed by centrifugation for 20 min at 180,000 *g*. The 27.5- and 25-kD tryptic fragments were recovered in the supernatant (Fig. 4, lane 1) and could not be recovered in the pellet when S₁ was centrifuged for 120 min at 300,000 *g* (Fig. 4, lanes 3), indicating that the soluble fragments were released from a nonmembrane anchored domain of the α -subunit. In contrast, the 32-kD frag-

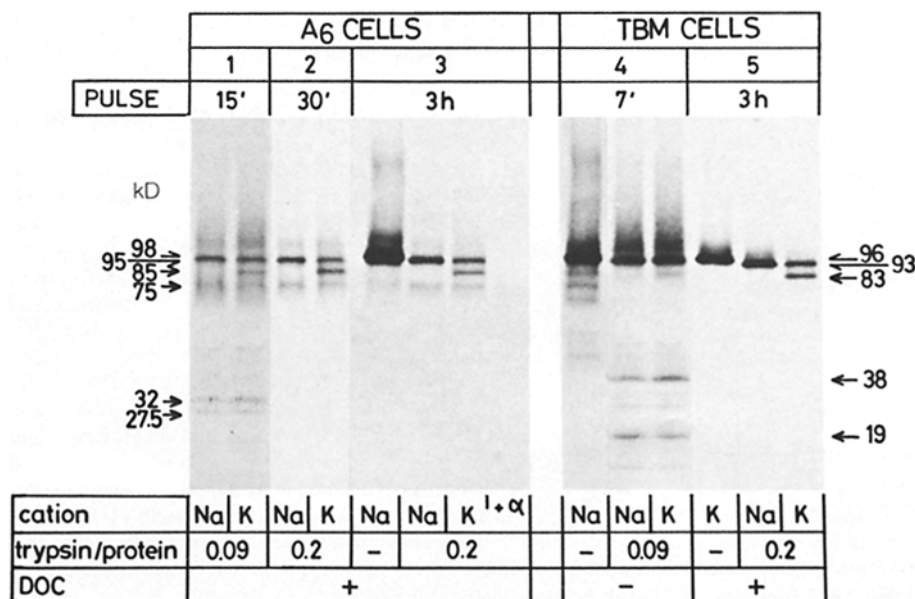

Figure 5. Cation-dependent conformation changes of the α -subunit of A6 and TBM Cells. (Lanes 1-3) Cell homogenates were obtained by sonication of A6 cells, pulse-labeled with [³⁵S]methionine for various times and incubated for 60 min at 0°C with or without trypsin at indicated trypsin/protein ratios in the presence of DOC (detergent/protein ratio: 0.2). Trypsinolysis was carried out in the presence of either 140 mM Na acetate or 140 mM K acetate and samples were then processed as described in Materials and Methods. (Lane 3 [+α]) Immunoprecipitation was performed in the presence of purified α -subunit (40 μ g per 250 μ g of cellular proteins). (Lanes 4 and 5) Cell homogenates obtained by sonication of TBM cells, pulse-labeled with [³⁵S]methionine for 7 min (lane 4) or 3 h (lane 5), were incubated for 60 min at 0°C with or without trypsin at indicated trypsin/protein ratios in the absence (lane 4) or presence (lane 5) of DOC at a detergent/protein ratio of 0.2, and with 140 mM Na acetate or 140 mM K acetate. Samples were then immunoprecipitated and revealed on SDS-PAGE by autoradiography as described in Materials and Methods.

ment was membrane associated since it was recovered in the 180,000 g pellet (Fig. 4, lane 2) and released into the supernatant when trypsinolysis was performed in the presence of 1% Triton X-100. Finally trypsin digestion in the presence of 1% Triton X-100 led to the disappearance of the 95- or 98-kD polypeptides in the P1 fractions (Fig. 4, lane 4) indicating that the tryptic sites were again accessible to cleavage in the presence of the detergent.

Cation-dependent Conformation Changes of the α -Subunit

Differences in tryptic fragmentation in the presence of Na^+ or K^+ have been observed for purified mammalian Na,K-ATPase (18). We have analyzed the tryptic fragmentation of the α -subunit in the presence of 140 mM Na or 140 mM K in the early, intermediate, and late compartments to determine whether the α -subunit could undergo cation-dependent conformation changes and to correlate these changes with the acquisition of protease resistance. After a 7-min pulse, the proteolytic pattern in A6 cells was identical when trypsinolysis was performed in the presence of Na^+ or K^+ (data not shown). After a 15-min pulse, the amount of 32- and 27.5-kD fragments recovered in the presence of Na^+ or K^+ was similar (Fig. 5, lane 1). In contrast, an 85-kD band was observed when trypsinolysis was carried out in the presence of K^+ , but not in the presence of Na^+ . This cation-dependent conformation change was better visualized when cells were labeled for longer periods of time and treated with a higher trypsin/protein ratio (Fig. 5, lanes 2 and 3). The 85-kD fragment produced in the presence of K^+ and a 75-kD fragment produced in the presence of K^+ and Na^+ were efficiently immunocompeted by an excess of purified α -subunit (Fig. 5, lane 3[+ α]), indicating that both fragments were related to the α -subunit.

The kinetics of acquisition of protease resistance were different in TBM cells than in A6 cells. After a 7-min pulse, the amount of protease resistant α -subunit was higher (Fig. 5, lane 4). As for A6 cells, however, the protease-sensitive population exhibited the same tryptic digest pattern in the presence of Na^+ or K^+ and distinct patterns were generated from the protease-resistant α -subunit when proteolysis was carried out in the presence of Na^+ or K^+ . An 83-kD fragment was generated in the presence of K^+ , but never with Na^+ (Fig. 5, lanes 4 and 5).

Thus, it appears that the α -subunit is unable to undergo cation-dependent conformation changes when newly synthesized in the RER. Maturation, which is associated with the acquisition of protease resistance during intracellular transport, is required for the expression of cation-induced conformation changes by the α -subunit of Na,K-ATPase.

Discussion

In this study, we have analyzed in two amphibian epithelial cell lines the structural changes of the catalytic α -subunit of Na,K-ATPase associated with its intracellular transport from its site of synthesis in the RER to its site of action at the cell surface. By a combination of pulse-chase experiments and controlled proteolysis followed by immunoprecipitation, we show that the α -subunit is trypsin sensitive immediately after synthesis. With time the α -subunit acquires protease resistance as well as the concomitant capacity to undergo cation-

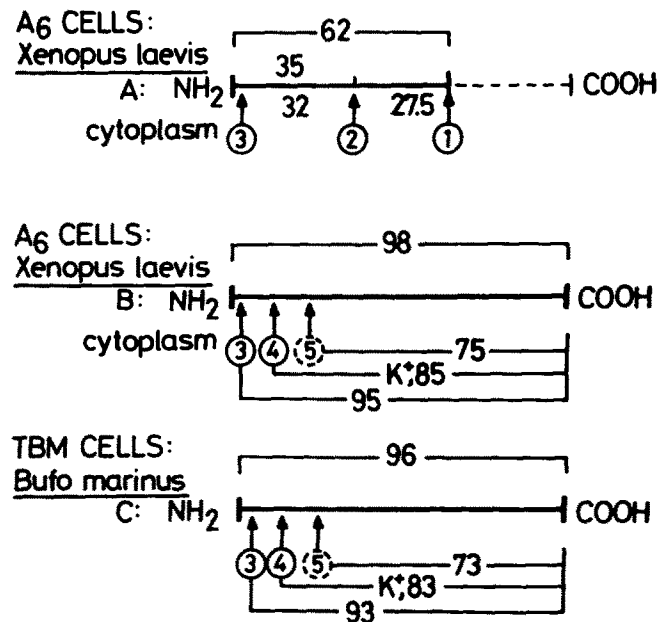

Figure 6. Tryptic cleavage patterns of the α -subunit from A6 and TBM cells. (A) Tryptic pattern of the α -subunit in an early transport compartment of A6 cells (7-min pulse). Tryptic sites 1, 2, and 3 are exposed in the presence of Na^+ or K^+ . (B and C) Tryptic pattern of the α -subunit in an intermediate (20-min chase) and late (180-min chase) transport compartment of A6 (B) or TBM (C) cells. Tryptic site 3 is exposed in the presence of Na^+ or K^+ . Tryptic site 4 is K^+ specific. Tryptic site 5 is revealed with high trypsin concentrations. In the Na^+ condition it is produced after cleavage of site 3, in the K^+ condition it is produced after cleavage of site 4 (data not shown). All tryptic sites have been assigned to the cytoplasmic domain of the α -subunit, since trypsinization of intact cells did not lead to the production of tryptic fragments (data not shown). The dashed line at the COOH terminus indicates that no fragments can be recovered from this region after trypsinolysis either because they are too small to be resolved on the gel system used or due to lack of recognition by the antibodies. For further explanation see text.

dependent conformation changes, a property of the mature Na,K pump.

Proteins involved in the transport of molecules and ions across cell membranes are believed to span the lipid bilayer several times (27, 31). Models for the membrane topology of the α -subunit of Na,K-ATPase have been proposed (26) based on chemical labeling (20) and protease digestion of SDS-purified enzyme (6, 18, 19) and on sequence data of the cloned mammalian (28) and Torpedo (22) α -subunit. As for many multi-spanning membrane-transport proteins, only small segments of the α -subunit are exposed at the extracytoplasmic face of the membrane. The polypeptide is predicted to span the membrane 6 (22) to 8 times (28). We have sequenced an α -subunit cDNA clone derived from *Xenopus laevis* kidney A6 cells (Verrey, F., P. Kairouz, E. Shaerer, P. Fuentes, K. Geering, B. C. Rossier and J. P. Kraehenbuhl, manuscript in preparation), mapped the putative tryptic cleavage sites as illustrated in the model of Fig. 6, and assigned the various tryptic peptides to the sequence of the amphibian α -subunit.

Immediately after synthesis (7-min pulse) in an early compartment corresponding to the RER, almost all α -subunit is protease sensitive. Two cleavage sites, which are exposed and

accessible to the enzyme, yield a 35-kD membrane-associated and a 27.5-kD soluble peptide. From the time course of trypsinolysis (Fig. 2), it appears that the more distal site is cleaved first generating a membrane-bound 62-kD fragment which in turn is digested into the 35- and 27.5-kD peptides (Fig. 6 A).

The 35-kD fragment appears to encompass the first four putative membrane-spanning domains and the cytoplasmic oriented NH₂-terminal extension. The soluble 27.5-kD fragment can be assigned to a segment situated in the large central hydrophilic domain which carries both the aspartyl-phosphate residue and the ATP-binding sequence. The tryptic digest pattern obtained in the early compartment immediately after synthesis of the α -subunit is similar to that obtained in cell-free translation experiments (12). In vitro, the α -subunit is cotranslationally inserted into rough microsomes; digestion with trypsin yields a 34-kD membrane-associated fragment which is likely to include the NH₂ terminus and the first four transmembrane domains. Both our in vivo and in vitro (12) data are consistent with a model for transport proteins, in which the membrane-spanning domains separated by a large hydrophilic cytoplasmic domain are sequentially inserted into the lipid bilayer (25). Trypsin resistance of the α -subunit, which is observed 10–20 min after synthesis has been completed, might result from the membrane insertion of the last three or four COOH-terminal membrane-spanning domains associated with a rearrangement of the large cytoplasmic domain. Concomitantly with the acquisition of protease resistance, the polypeptide chain can adopt E₁–E₂ conformation changes which can be detected by controlled trypsinolysis. In the presence of K⁺, but not Na⁺, a tryptic site corresponding to Lys₁₄₆ or Lys₁₄₉ in the first cytoplasmic loop is exposed and accessible to tryptic digestion yielding an 83-kD fragment (Fig. 6 B). This site is not cleaved in the purified mammalian enzyme, but a more distal site (Arg₄₂₃) on the large central hydrophilic domain is digested in KCl yielding two peptides of 56- and 40-kD (6, 28). A similar pattern was observed with the amphibian enzyme, when kidney microsomes were prepared by Potter homogenization rather than sonication (32). The reason for this difference is not understood. Finally the NH₂-terminal tryptic site (Lys 18), which is rapidly cleaved in NaCl, but inaccessible in KCl in the mammalian enzyme (18, 23) does not exhibit cation-dependent conformation change in the amphibian α -subunit. This site is cleaved in the presence of either K or Na yielding the 95-kD fragment from the 98-kD α -subunit, or the 32-kD fragment from the 35-kD peptide.

The mechanisms underlying the increase in protease resistance of the α -subunit during its intracellular transport is not known. The β -subunit might play a crucial role in the membrane insertion of the α -subunit. In the in vitro system (12), the α -subunit can be inserted into microsomes in the absence of mRNA coding for the β -subunit, but the polypeptide chain is unable to adopt the configuration of the mature enzyme. Other proteins might also be required for proper assembly of the Na,K-ATPase. Our data suggest that the α -subunit undergoes transition from an inactive to an active form in route from its site of synthesis to the cell surface. Functional maturation of the α -subunit during intracellular transport is supported by recent experiments of Caplan et al. (4) who showed that the Na,K pump has not yet acquired all its biochemical

functions immediately after synthesis. About 10 min are required for the newly synthesized enzyme to be able to adopt an E₂P configuration competent to bind ouabain. Whether the structural rearrangement that we have detected during intracellular transport is associated with the functional maturation of the Na,K pump observed by Caplan et al. (4) remains to be established by further experiments.

We would like to acknowledge the excellent technical assistance of Ms. Sophie Perret-Gentil and to thank P. L. Jørgensen and D. Warnock for valuable suggestions during the preparation of this manuscript.

This work was supported by grants 3.398-086 and 3.399-086 from the Swiss National Fund for Scientific Research.

Received for publication 8 April 1987, and in revised form 29 May 1987.

References

- Anner, B. M. 1985. Interaction of (Na⁺+K⁺)-ATPase with artificial membranes. I. Formation and structure of (Na⁺+K⁺)-ATPase-liposomes. *Biochim. Biophys. Acta.* 822:319–334.
- Anner, B. M. 1985. Interaction of (Na⁺+K⁺)-ATPase with artificial membranes. II. Expression of partial transport reactions. *Biochim. Biophys. Acta.* 832:335–353.
- Caplan, M. J., H. C. Anderson, G. E. Palade, and J. D. Jamieson. 1986. Intracellular sorting and polarized cell surface delivery of (Na⁺,K⁺)-ATPase, an endogenous component of MDCK cell basolateral plasma membranes. *Cell.* 46:623–631.
- Caplan, M. J., G. E. Palade, and J. D. Jamieson. 1985. Cell surface expression and activation of newly synthesized Na,K-ATPase in MDCK cells. In *The Sodium Pump*. I. Glynn and C. Ellory, editors. The Company of Biologists, Ltd. Cambridge. 147–151.
- Caplan, M. J., G. E. Palade, and J. D. Jamieson. 1986. Newly synthesized Na,K-ATPase α -subunit has no cytosolic intermediate in MDCK cells. *J. Biol. Chem.* 261:2860–2865.
- Castro, J., and R. A. Farley. 1979. Proteolytic fragmentation of the catalytic subunit of the sodium and potassium adenosine triphosphatase. *J. Biol. Chem.* 254:2221–2228.
- Fambrough, D. M. 1983. Studies on the (Na⁺-K⁺)ATPase of skeletal muscle and nerve. *Cold Spring Harbor Symp. Quant. Biol.* 48:297–304.
- Fisher, J. A., L. A. Baxter-Lowe, and L. E. Hokin. 1984. Site of synthesis of the α and β subunits of the Na,K-ATPase in brine shrimp nauplii. *J. Biol. Chem.* 259:14217–14221.
- Forbush, B., III. 1982. Characterization of right-side-out membrane vesicles rich in (Na,K)-ATPase and isolated from dog kidney outer medulla. *J. Biol. Chem.* 257:12678–12684.
- Geering, K., M. Claire, H. P. Gaeggeler, and B. C. Rossier. 1985. Receptor occupancy vs. induction of Na⁺-K⁺-ATPase and Na⁺ transport by aldosterone. *Am. J. Physiol.* 248:C102–C108.
- Geering, K., M. Girardet, C. Bron, J. P. Kraehenbuhl, and B. C. Rossier. 1982. Hormonal regulation of (Na⁺,K⁺)-ATPase biosynthesis in the toad bladder: effect of aldosterone and 3,5,3'-triiodo-L-thyronine. *J. Biol. Chem.* 257:10338–10343.
- Geering, K., D. I. Meyer, M. P. Paccolat, J. P. Kraehenbuhl, and B. C. Rossier. 1985. Membrane insertion of α - and β -subunits of Na⁺,K⁺-ATPase. *J. Biol. Chem.* 260:5154–5160.
- Girardet, M., K. Geering, J. M. Frantes, D. Geser, B. C. Rossier, J. P. Kraehenbuhl, and C. Bron. 1981. Immunocytochemical evidence for a transmembrane orientation of both the (Na⁺,K⁺)-ATPase subunits. *Biochemistry.* 20:6684–6691.
- Handler, J. S. 1983. Use of cultured epithelia to study transport and its regulation. *J. Exp. Biol.* 106:55–69.
- Handler, J. S., R. E. Steele, M. K. Sahib, J. B. Wade, A. S. Preston, N. L. Lawson, and J. P. Johnson. 1979. Toad urinary bladder epithelial cells in culture: maintenance of epithelial structure, sodium transport, and response to hormones. *Proc. Natl. Acad. Sci. USA.* 76:4151–4155.
- Hiatt, A., A. A. McDonough, and I. S. Edelman. 1984. Assembly of the (Na⁺,K⁺)-adenosine triphosphatase. Post-translational membrane integration of the α -subunit. *J. Biol. Chem.* 259:2629–2635.
- Jørgensen, P. L. 1975. Purification and characterization of (Na⁺,K⁺)-ATPase. V. Conformational changes in the enzyme. Transitions between the Na-form and the K-form studied with tryptic digestion as a tool. *Biochim. Biophys. Acta.* 401:399–415.
- Jørgensen, P. L. 1977. Purification and characterization of (Na⁺,K⁺)-ATPase. VI. Differential tryptic modification of catalytic functions of the purified enzyme in presence of NaCl and KCl. *Biochim. Biophys. Acta.* 466:97–108.
- Jørgensen, P. L. 1986. Structure, function and regulation of Na,K-ATPase in the kidney. *Kidney Int.* 29:10–20.
- Jørgensen, P. L., S. J. D. Karlish, and C. Gitler. 1982. Evidence for the organization of the transmembrane segments of (Na,K)-ATPase based on

- labeling lipid-embedded and surface domains of the α -subunit. *J. Biol. Chem.* 257:7435-7442.
21. Kashgarian, M., D. Biemesderfer, M. Caplan, and B. Forbush, III. 1985. Monoclonal antibody to Na,K-ATPase: immunocytochemical localization along nephron segments. *Kidney Int.* 28:899-913.
 22. Kawakami, K., S. Noguchi, M. Noda, H. Takahashi, T. Ohta, M. Kawamura, H. Nojima, K. Nagano, T. Hirose, S. Inayama, H. Hayashida, T. Miyata, and S. Numa. 1985. Primary structure of the α -subunit of *Torpedo californica* (Na⁺+K⁺)ATPase deduced from cDNA sequence. *Nature (Lond.)*. 316:733-736.
 23. Kornfeld, R., and S. Kornfeld. 1985. Assembly of asparagine-linked oligosaccharides. *Annu. Rev. Biochem.* 54:631-664.
 24. Lowry, O. H., N. J. Rosebrough, A. L. Farr, and R. J. Randall. 1951. Protein measurement with the folin phenol reagent. *J. Biol. Chem.* 193:265-275.
 25. Mueckler, M., and H. F. Lodish. 1986. The human glucose transporter can insert posttranslationally into microsomes. *Cell.* 44:629-637.
 26. Ohta, T., K. Nayano, and M. Yoshida. 1986. The active site of Na⁺/K⁺-transporting ATPase: location of the S'-(p-fluorosulfonyl)benzoyl-adenosine binding site and soluble peptides released by trypsin. *Proc. Natl. Acad. Sci. USA.* 83:2011-2013.
 27. Sabatini, D. D., G. Kreibich, T. Morimoto, and M. Adesnik. 1982. Mechanisms for the incorporation of proteins in membrane and organelles. *J. Cell Biol.* 92:1-22.
 28. Shull, G. E., A. Schwartz, and J. B. Lingrel. 1985. Amino-acid sequence of the catalytic subunit of the (Na⁺+K⁺)ATPase deduced from a complementary DNA. *Nature (Lond.)*. 316:691-695.
 29. Sztul, E. S., D. Biemesderfer, M. J. Caplan, M. Kashgarian, and J. L. Boyer. 1987. Localization of Na⁺,K⁺-ATPase α -subunit to the sinusoidal and lateral but not canalicular membranes of rat hepatocytes. *J. Cell Biol.* 104:1239-1248.
 30. Tamkun, M. M., and D. M. Fambrough. 1986. The (Na⁺+K⁺)-ATPase of chick sensory neurons. Studies on biosynthesis and intracellular transport. *J. Biol. Chem.* 261:1009-1019.
 31. Wickner, W. T., and H. F. Lodish. 1985. Multiple mechanisms of protein insertion into and across membranes. *Science (Wash. DC)*. 230:400-407.
 32. Zamofing, D., B. C. Rossier, and K. Geering. Structural organization of α -subunit from purified and microsomal toad kidney Na,K-ATPase as assessed by controlled trypsinolysis. *Biochim. Biophys. Acta.* In press.