

# MAP3K6 Mutations in a Neurovascular Disease Causing Stroke, Cognitive Impairment, and Tremor

Andreea Ilinca, MD, PhD, Elisabet Englund, MD, PhD, Sofie Samuelsson, MSc, Katarina Truvé, PhD, Efthymia Kafantari, MSc, MSc, Nicolas Martinez-Majander, MD, Jukka Putaala, MD, PhD, Claes Håkansson, MD, Arne G. Lindgren, MD, PhD,\* and Andreas Puschmann, MD, PhD\*

## Correspondence

Dr. Ilinca  
Andreea.Ilinca@med.lu.se

*Neurol Genet* 2021;7:e548. doi:10.1212/NXG.0000000000000548

## Abstract

### Objective

To describe a possible novel genetic mechanism for cerebral small vessel disease (cSVD) and stroke.

### Methods

We studied a Swedish kindred with ischemic stroke and intracerebral hemorrhage, tremor, dysautonomia, and mild cognitive decline. Members were examined clinically, radiologically, and by histopathology. Genetic workup included whole-exome sequencing (WES) and whole-genome sequencing (WGS) and intrafamilial cosegregation analyses.

### Results

Fifteen family members were examined clinically. Twelve affected individuals had white matter hyperintensities and 1 or more of (1) stroke episodes, (2) clinically silent lacunar ischemic lesions, and (3) cognitive dysfunction. All affected individuals had tremor and/or atactic gait disturbance. Mild symmetric basal ganglia calcifications were seen in 3 affected members. Postmortem examination of 1 affected member showed pathologic alterations in both small and large arteries the brain. Skin biopsies of 3 affected members showed extracellular amorphous deposits within the subepidermal zone, which may represent degenerated arterioles. WES or WGS did not reveal any potentially disease-causing variants in known genes for cSVDs or idiopathic basal ganglia calcification, but identified 1 heterozygous variant, NM\_004672.4 *MAP3K6* c.322G>A p.(Asp108Asn), that cosegregated with the disease in this large family. *MAP3K6* has known functions in angiogenesis and affects vascular endothelial growth factor expression, which may be implicated in cerebrovascular disease.

### Conclusions

Our data strongly suggest the *MAP3K6* variant to be causative for this novel disease phenotype, but the absence of functional data and the present lack of additional families with this disease and *MAP3K6* mutations still limit the formal evidence for the variant's pathogenicity.

\*These authors contributed equally.

From the Department of Clinical Sciences Lund, Neurology (A.I., E.K., A.G.L., A.P.), Lund University; Section of Neurology (A.I., E.K., A.G.L., A.P.), Skåne University Hospital, Lund; Department of Clinical Genetics and Pathology (E.E., S.S.), Laboratory Medicine, Region Skåne; Department of Clinical Sciences Lund (E.E.), Division of Pathology, Lund University; Bioinformatics Core Facility (K.T.), Sahlgrenska Academy at University of Gothenburg, Sweden; Neurology (N.M.-M., J.P.), University of Helsinki, and Helsinki University Hospital, Finland; Department of Imaging and Function (C.H.), Skåne's University Hospital, Lund; and Department of Clinical Sciences, Diagnostic Radiology (C.H.), Lund University, Sweden

Go to [Neurology.org/NG](https://www.neurology.org/NG) for full disclosures. Funding information is provided at the end of the article.

The Article Processing Charge was funded by the authors.

This is an open access article distributed under the terms of the Creative Commons Attribution-NonCommercial-NoDerivatives License 4.0 (CC BY-NC-ND), which permits downloading and sharing the work provided it is properly cited. The work cannot be changed in any way or used commercially without permission from the journal.

## Glossary

**ASK2** = apoptosis signal-regulating kinase; **cSVD** = cerebral small vessel disease; **HE** = hematoxylin and eosin; **JNK** = c-Jun N-terminal kinase; **MAP2K6** = mitogen-activated protein kinase; **VEGF** = vascular endothelial growth factor; **WES** = whole-exome sequencing; **WGS** = whole-genome sequencing; **WMHs** = white matter hyperintensity.

Cerebrovascular diseases are important causes of mortality and morbidity, resulting in stroke and leading to functional, psychiatric, and cognitive impairment. Today, stroke is considered to be a highly heritable disease,<sup>1,2</sup> but known monogenic phenotypes of stroke associated with cerebral small vessel disease (cSVD) only explain a small fraction of the disease incidence.<sup>2,3</sup>

cSVDs affect small vessels of the brain, including small arteries, arterioles, capillaries, and venules and their interactions with perivascular structures,<sup>4</sup> which may result in both acute ischemic stroke and intracerebral hemorrhage and chronic asymptomatic findings in neuroimaging including white matter hyperintensities (WMHs), microbleeds, and enlarged perivascular spaces.<sup>5</sup> The presence and sometimes disease-specific appearance of neuroimaging biomarkers facilitate phenotyping studies of cSVD-associated stroke compared with other subtypes of stroke, and several genetically defined conditions resulting in cSVD stroke have been identified to date. Supplemental data e1 and table 1 (links.lww.com/NXG/A364) lists the known monogenic forms of stroke due to cSVD, including the 22 genes we previously compiled<sup>6</sup> and additional entities described since that publication. Nevertheless, the pathogenic mechanisms of these diseases remain poorly understood,<sup>7</sup> and as a consequence, the possibilities to treat stroke related to cSVDs remained modest.

Here, we present a large pedigree with a novel later-onset cerebral autosomal dominant vasculopathy causing stroke episodes, mild cognitive impairment, cerebellar signs, and dysautonomia.

## Methods

Three patients of the same family from Southern Sweden presented with cerebellar symptoms and signs, mild cognitive deficits, orthostatic hypotension (OH), white matter hyperintensities, and/or stroke episodes. They were investigated clinically and neuroradiologically, and a common hereditary cause was suspected. The Montreal Cognitive Assessment version 7.0 and personal interview were used to assess cognition.<sup>8</sup> Subsequently, these 3 individuals and 12 additional family members (FMs) were included in the present study and personally interviewed and examined by a neurologist. Medical records of 5 additional living or deceased FMs were reviewed (figure 1).

FMs presenting with white matter intensities on MRI and 1 or more of (1) clinical strokes, (2) lacunar brain infarcts, (3)

cognitive dysfunction, and/or (4) tremor and/or atactic gait disturbance were considered affected. Individuals without any of the clinical features (2) to (4) and without signs of white matter changes on a neuroradiologic examination performed after age 48 years were considered as unaffected. Individuals who had not undergone neuroradiologic examination, for whom relevant information was missing, or who were younger than 48 years at clinical or normal radiologic examination were classified as undetermined status for the purpose of the subsequent genetic analyses (table 1 and table e1, links.lww.com/NXG/A364 and links.lww.com/NXG/A365).

## Radiology

Brain MRI using a 1.5-T system from 10 FMs was obtained or reviewed within this study. Six members, including 4 individuals who had been deceased at study start, had only been examined by CT. Images of the supra-aortic vasculature and intracerebral vessels and the results from cardiologic investigations and extensive blood tests including the analysis of prothrombotic factors were compiled as available from the FMs' medical records (table e1, links.lww.com/NXG/A365). One neuroradiologist who remained blinded to clinical symptoms and genetic results reviewed available MRI examinations. Where MRI was not available, assessments were performed on axial CT images. Findings were classified with predefined criteria compiled for this study (not shown). The presence of recent and older infarcts, lacunes of presumed vascular origin, WMHs, atrophy, and cerebral microbleeds was evaluated when possible.

## Genetic Analyses

Clinical diagnostic testing had excluded pathogenic mutations for cerebral autosomal dominant arteriopathy with subcortical infarcts and leukoencephalopathy, spinocerebellar ataxia types 1, 2, 3, 6, and 7, and fragile X tremor ataxia syndrome. DNA samples were obtained from 14 FMs.

We examined whole-genome sequencing (WGS) data from nuclear and mitochondrial DNA from the proband for the presence of rare genetic variation in 31 known genes for monogenic cSVD-related stroke from our Stroke Gene Panel<sup>6</sup> and recent publications, 2 genes for cerebral amyloid angiopathy with no known association to stroke, and genes that are known causes of familial basal ganglia calcification. We considered all variants up to an allele frequency of 5% in 1000 Genomes,<sup>9</sup> SweGene,<sup>10</sup> and ExAC<sup>11</sup> (supplemental data e1). No potentially pathogenic variant was identified.

The proband and 7 additional FMs, 6 affected and 1 unaffected, were genetically tested by whole-exome sequencing

**Figure 1** Pedigree Drawing of the Family

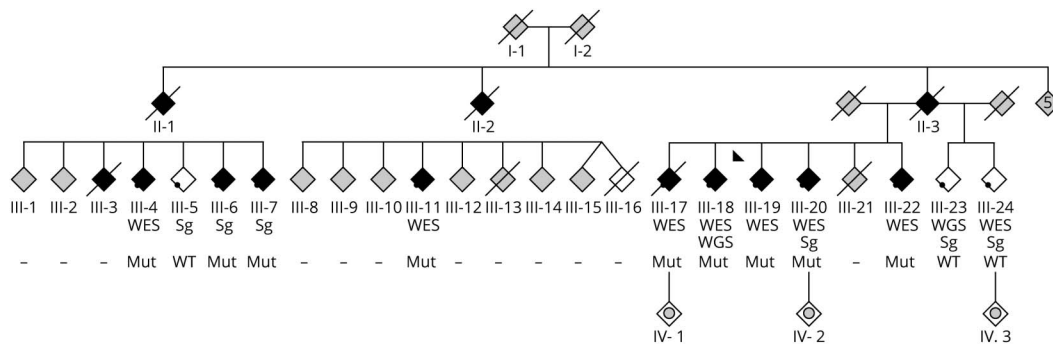

Sex has been masked, and the number and order of siblings altered to protect participants' confidentiality. Black diamonds represent affected individuals, gray diamonds individuals not examined, and white diamonds clinically unaffected individuals. Diamonds with round circle denote uncertain status. A dot at the left inferior edge of a diamond means the individual was genetically analyzed. A diagonal line indicates that the individual is deceased. A total of 20 individuals were studied (II.1–3; III.3–7, 11, 17–20, 22–24; IV.1–3). Eight affected (II.3, III.4, 11, 17–20, 22), 2 unaffected (III.23 and 24), and 5 relatives with undetermined clinical status (III.6,7; IV.1, IV.3) were studied in person. Medical records were also retrieved from (II.1,2; III.3,16; and IV.2). DNA was obtained for 14 individuals and for 12 of them (III.4–7, 11, 17–20, 22–24) was analyzed in this study, whereas individuals IV.1 and IV.3 were not analyzed genetically because of their young age. Skin biopsies from 5 affected (III.11, 18–20, 22) and 1 unaffected individual (III.24) were examined. Sg = Sanger sequencing of the *MAP3K6* c.322G>A p.(Asp108Asn) variant; Mut = the mutated variant is present; WES = whole-exome sequencing; WGS = whole-genome sequencing; Wt = wild type.

(WES, figure 1). These data were used for cosegregation analysis, filtering out, in a stepwise fashion, all variants that were not present in all the 7 affected or not absent in the unaffected individuals (supplemental data e1).

One variant that could possibly explain the disease was identified and further analyzed. Sanger sequencing (Applied Biosystems) was performed in III.18 and III.24 where it confirmed the WES results and in 4 additional FMs (figure 1). We determined the haplotype segment around the *MAP3K6* variant shared by all affected members who had been analyzed by WES or WGS and searched this segment for sequence, copy number, and tandem repeat variants in WGS data from III.18. We searched for rare variants in *MAP3K6* in WES data from the previously published probands of 22 families with young-onset familial stroke<sup>12</sup> (table e2, [links.lww.com/NXG/A364](https://links.lww.com/NXG/A364)).

### Neuropathology

The brain of the proband's deceased sibling (III.17) was examined neuropathologically. Two additional FMs (III.3 and III.16) had undergone postmortem examinations, and we reviewed their pathology reports. Skin biopsies were obtained from 6 members to examine for signs of systemic small vessel disease. Biopsies were stained with hematoxylin & eosin (HE) or Elastica-van Gieson (EVG) for collagen and elastic fibers and examined by light microscopy. The density of intra-epidermal nerve endings was determined with immunohistochemical stain for protein gene product 9.5.<sup>13,14</sup> Biospecimens were also examined by electron microscopy, where sections containing small blood vessels were photographed for evaluation of blood vessel ultrastructure.

### VEGF Measurements

*MAP3K6* influences vascular endothelial growth factor (VEGF) activation in cell models. We compared resting state

VEGF levels in serum samples from 11 FMs (8 *MAP3K6* variant carriers and 3 noncarriers) with 12 age-matched and sex-matched patients from a dystonia cohort who had normal cognitive status, no clinical or radiologic evidence of stroke, no white matter abnormalities in MRI, no history of malignancy, and no diabetes mellitus. Analyses were performed with ELISA, using the Quantikine human VEGF kit (R&D Biosystems) according to the manufacturer's instructions and as used in clinical diagnostics practice at the Department for Clinical Immunology and Transfusion Medicine, Region Skåne, Sweden. VEGF levels were performed in duplicate, and the Mann Whitney *U* test was used for statistical analyses.

Written informed consent was obtained from all patients participating in the study according to the Declaration of Helsinki. The study was approved by the Regional Ethical Review Board in Lund.

### Data Availability

Original data can be made available on request; individual genetic or clinical data may underlie legal or institutional restrictions and may require a Material and/or Data Transfer Agreement with Region Skåne, Sweden.

### Results

Clinical data from 20 FMs were compiled. Eight affected, 2 unaffected, and 5 FMs with undetermined clinical status were personally interviewed and clinically evaluated by a neurologist for the purpose of this study. Medical records of further 5 living or deceased FMs were reviewed (figure 1, table 1, and table e1, [links.lww.com/NXG/A365](https://links.lww.com/NXG/A365)).

Of the affected FMs, 2 did not have any known vascular risk factors (hypertension, diabetes, smoking, atrial fibrillation,

**Table 1** Summary of the Clinical, Radiologic, and Genetic Data From This Kindred

Individual	II.3	III.4	III.5	III.6	III.7	III.11	III.17	III.18	III.19	III.20	III.22	III.23	III.24
<b>Stroke subtype (age)</b>	—	—	—	—	—	—	ICH (62 y)	—	—	SVD (63 y)	—	LAA (53 y)	<sup>a</sup>
<b>Imaging</b>													
<b>Lacunar infarcts</b>	Yes	No	N/A	No	No	No	Yes	Yes	Yes	Yes	No	No	No
<b>WMHs<sup>b</sup></b>	Yes	Yes	N/A	Yes	Yes	Yes	Yes	Yes	Yes	Yes	Yes	No	No
<b>Basal ganglia calcification</b>	No	Yes	N/A	Yes	No	Yes	No	No	No	No	No	No	No
<b>Cognitive dysfunction</b>	Yes	Yes	N/A	Yes	No	Yes	Yes	Yes	Subj.	Subj.	No	No	Yes
<b>Depression/anxiety</b>	No	No	N/A	Yes	Yes	No	Yes	No	Yes	No	Yes	No	Yes
<b>Vascular risk factors</b>													
<b>Hypertension</b>	No	No	No	No	No	No	No	No	No	Yes	Yes	No	No
<b>Diabetes mellitus</b>	No	No	No	No	No	No	No	No	No	No	No	No	No
<b>Atrial fibrillation</b>	No	No	No	Yes	Yes	No	Yes	No	No	Yes	No	No	No
<b>Smoking</b>	Yes	Ex	Yes	No	No	No	Yes	No	Ex	No	Ex	Ex	Yes
<b>Hypercholesterolemia</b>	No	No	Yes	No	No	No	No	No	No	No	No	Yes	No
<b>Neurologic signs/symptoms</b>													
<b>Tremor/atactic gait</b>	T, A	A	N/A	T	T	A	T, A	T	T, A	T, A	T	No <sup>c</sup>	No
<b>OH</b>	Yes	Yes	N/A	Yes	Yes	No	Yes	No	No	Yes	Yes	No	No
<b>Migraine</b>	No	No	No	No	No	Yes	No	No	No	Yes	Yes	No	Yes
<b>Assumed clinical status</b>	Aff	Aff	Und	Aff	Und	Aff	Aff	Aff	Aff	Aff	Aff	Unaff	Unaff
<b>MAP3K6 c.322G&gt;A genotype</b>	Obl	MUT	Wt	MUT	MUT	MUT	MUT	MUT	MUT	MUT	MUT	Wt	Wt

Abbreviations: A = atactic gait or other ataxia; Aff = affected; Ex = previous smoker; ICH = intracerebral hemorrhage; LAA = large artery atherosclerosis; MUT = heterozygous *MAP3K6* c.322G>A variant; N/A = not assessed; Obl = obligate carrier; OH = orthostatic hypotension; SDH = subdural hematoma; SVD = small vessel disease; T = tremor; Und = undetermined; WMH = white matter hyperintensity; Wt = wild type.

Individuals not personally clinically examined and/or with uncertain clinical status not included.

<sup>a</sup> This individual had an acute posttraumatic subdural hematoma at age 53 years.

<sup>b</sup> Compatible with cerebral small vessel disease.

<sup>c</sup> No history of gait disturbance before stroke or of tremor.

and hypercholesterolemia), 5 of 8 were present or previous smokers, 3/8 developed atrial fibrillation later in life, and 2/8 had hypertension. Six of 8 affected FMs showed signs of autonomous nervous system dysfunction, with blood pressure lability and tendency to symptomatic OH episodes. Although only 2/8 had clinically manifest stroke episodes, which included lethal cerebellar hemorrhage (III.17), brain MRI of these 2 and another 3/8 revealed asymptomatic ischemic lesions in a small vessel territory. No microbleeds were identified on the available images for 6/8 affected FMs and for 1/2 unaffected FM. All 8 affected individuals had WMHs (figure 2), and these were located in the deep (8/8) and periventricular (7/8) white matter and in the brain stem (mesencephalon or pons, 3/8). They were distributed symmetrically in 5/8 members, were nonconfluent (Fazekas 1) in 6/8, and confluent (Fazekas 2 or 3) only in 2.

Seven of 8 FMs had objective or subjective cognitive dysfunction. All the affected individuals presented tremor or

dyscoordination of movements symmetrically involving the upper and lower extremities, and 2/8 also presented saccadic horizontal eye movements on smooth pursuit, and 2 also had hypokinesia. Three affected and 1 unaffected FM had migraine.

Three of the FMs carrying the *MAP3K6* variant also had mild symmetric calcifications in the basal ganglia, globi pallidi (table e1, [links.lww.com/NXG/A365](https://links.lww.com/NXG/A365)). Four (III.4, III.17, III.18, and III.20) of 8 affected FM had short stature, small hands, and mild dysmorphic facial traits (low-set, cupped ears). Three of 8 affected FMs had performed imaging of cerebral extra- or intracranial vessels (by duplex ultrasound examination of the carotid and vertebral arteries, CT angiography, or neuropathology), and only the autopsied patient (III.17) showed pathologic changes on the larger vessels of the brain; 2 others had arteriosclerotic changes in the cardiac coronary arteries. ECGs and echocardiography showed atrial

**Figure 2** Neuroimaging of 9 Affected Family Members

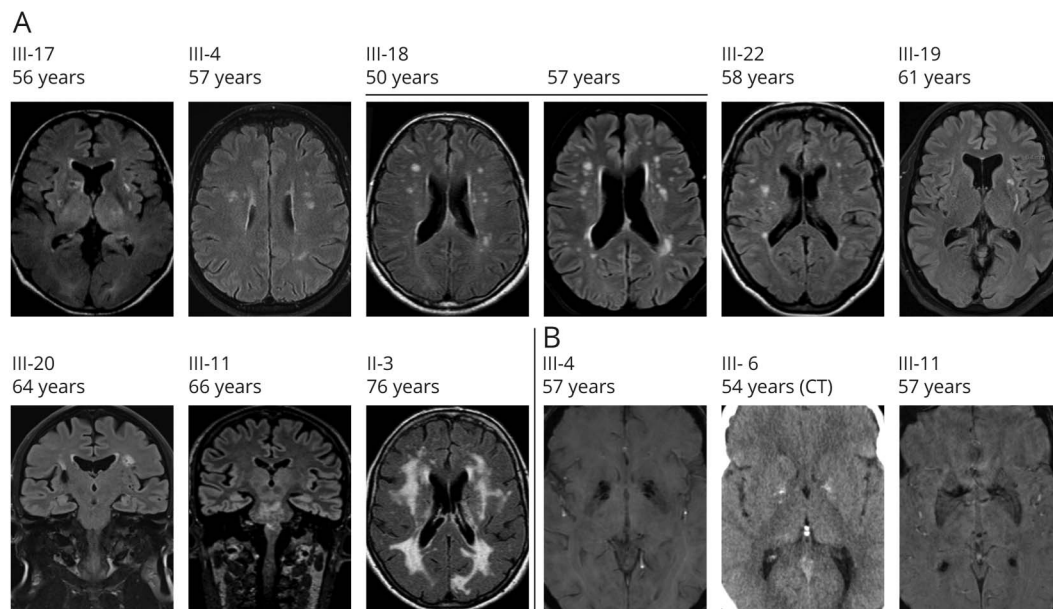

(A) WMHs in the deep and periventricular white matter and in the brain stem (mesencephalon or pons). Images are ordered according to age at examination. Individual III.18 was examined twice with an interval of 7 years; a clear increase in the number and size of lesions is visible. Planes that showed the most prominent changes are shown for each individual. On these images, lacunar infarcts are visible for individuals III.17 and III.20. Additional images are shown in table e1. (B) Mild calcifications in the globi pallidi were visible on MRI or CT of these 3 affected individuals. WMH = white matter hyperintensity.

fibrillation in 2 and mild or moderate left ventricular hypertrophy in 3/8 affected individuals, but none had any large artery brain infarction. None of the affected FMs showed coagulation abnormalities.

### Genetic Analyses

WGS of the proband revealed 19 variants in the genes listed in supplemental data e1 with allele frequency below 5% in any of the 3 databases. However, none of these were considered potentially pathogenic (supplemental data e1).

Cosegregation analysis was performed using variants with an allele frequency below 0.05 that were identified by WES from 8 individuals (7 affected and 1 unaffected). This unambiguously identified exactly 1 variant shared by all the persons with the disease and not present in the unaffected half sibling of the proband, that was exonic and was prognosticated to be highly deleterious in several prediction tools (Combined Annotation Dependent Depletion score 32; supplemental data e1). The variant is on chromosome 1, NM\_004672.4 *MAP3K6* c.322G>A p.(Asp108Asn), rs947285063. This variant is entirely absent in the gnomAD database. Sanger sequencing confirmed WES results in 2 individuals and identified *MAP3K6* c.322G>A in 2 additional affected members, whereas 2 additional members not fulfilling the clinical criteria did not carry the variant (figure e1). The variant was on a 1.39Mbp shared haplotype; within this segment, we found no other potentially causative sequence, copy number, or tandem repeat alteration (supplemental data e1).

Four of the 22 probands from other families with familial stroke syndromes<sup>12</sup> carried rare variants in *MAP3K6* (table e2, links.lww.com/NXG/A364). Two of these were synonymous. One (NM\_004672 c.1256-2A>G) was in an intronic splice site, leading to higher scores in prediction tools, but this variant was relatively common (0.37% of alleles in gnomAD) and thus considered too common to cause a very rare disorder.

### Neuropathology

Neuropathologic examination of the brain of the affected individual III.17 showed no macroscopic atrophy but revealed superficial white-colored winding arteries, seemingly stiffened by changes primarily judged as arteriosclerosis. Microscopically, the vessels exhibited an irregular multinodular intimal-subintimal proliferation with few cells but an expanded extracellular volume (figure 3). The regressive collagenous muscular lamina interna was often degenerated, and there were foci of inflammatory cells and fibrosis in the vessel walls. The EVG staining revealed that the elastic layer had regressive changes, in part with a single, in part with a double layer. The external muscular lamina had a normal appearance. These alterations were pronounced in large extracerebral arteries and in small penetrant arteries in the basal ganglia, but only moderate in arterioles. There was further a moderately severe small vessel disease and cortical microvascular proliferation. Gray matter structures, i.e., the cortex and the central nuclei, did not reveal any pathology. The white matter had an unspecific thinning, without marked gliosis or cellular changes, but there was a mild

reduction of myelin, in addition to the described vessel changes. Immunohistochemical stainings for tau, alpha-synuclein, TDP-43, and p62 were negative. No amyloid deposits were identified. Electron microscopy revealed moderate thickening of arteriole walls and no osmiophilic deposits.

In 3/5 affected members (III.11, III.18, and III.19), skin biopsies showed extracellular amorphous deposits located immediately under the epidermis, apparently directly adjacent to ascending central arteries in dermal papillas. They had a bluish-gray coloration in HE and were distinctly dark in EVG staining (figure 3, G and H). They were absent in the unaffected FM. Intraepidermal nerve fiber density was mildly reduced in 2 affected members (III.11 and III.19). Otherwise, light microscopy showed normal skin architecture, and there were no signs of inflammation. Electron microscopy of arterioles from skin biopsies showed increased thickness of both muscularis and endothelial layers.

The brains of III.3 and III.16 patients were only examined macroscopically, outside this research study; lacunar infarcts were documented for III.3, and no specific findings were

reported for III.16. None of these members were analyzed genetically, but the available medical records suggested that III.3 may have been affected and III.16 unaffected.

## VEGF Measurements

There was no statistically significant difference of baseline serum VEGF levels between 8 affected FMs and 8 matched controls (supplemental data e2). Similarly, there was no difference between these 8 mutation carriers and 3 noncarrier relatives tested, nor was there a difference between all mutation carriers and all noncarriers (familial and others) combined.

## Discussion

We describe a large Swedish family with cerebral and brain-stem WMHs and stroke episodes, lacunar ischemic lesions, mild cognitive dysfunction, and cerebellar signs including tremor and atactic gait disturbance. Mild symmetric basal ganglia calcifications were seen in 3 affected members. Brain pathology of one affected individual showed pronounced angiopathy in large and small cerebral arteries. Skin biopsies were taken from 5 clinically or radiologically affected

**Figure 3** Pathology in Brain and Skin Vessels

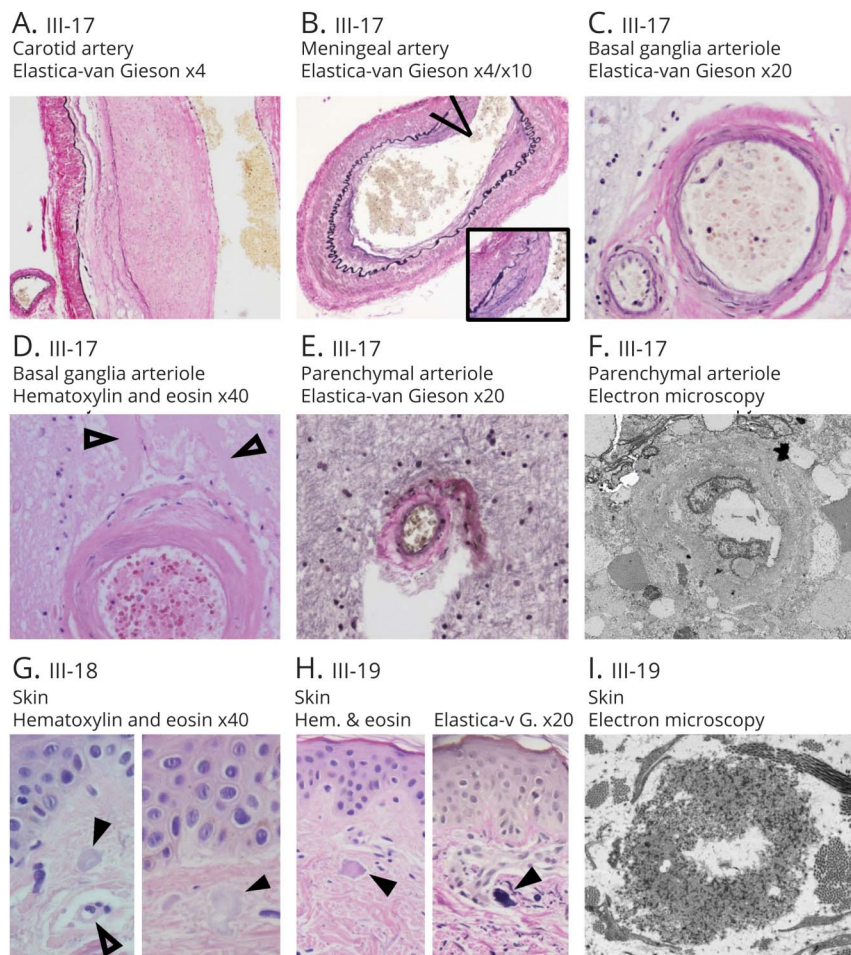

(A–F) Photomicrographs of specimens from the neuropathologic examination of individual III.17. (A and B) Large arteries showed pronounced arteriosclerotic-like pathology with irregular multi-nodular intimal/subintimal proliferation. (C–F) Small vessels (approximately 0.2 mm diameter and below) showed moderate concentric thickening of the vessel wall with degenerative loosening and extravasation. (B and C) The elastica (dark violet) is irregular in thickness, at parts consisting of 2 layers. (D) Extravasated homogeneous fluid accumulation (non-filled arrowheads). (E) Concentric thickening of the walls of parenchymal arterioles, sometimes with double layers, and uneven intimal fibrosis. (F) Electron microscopy revealed increased vessel wall thickness, of both muscular and intimal layers. (G–I) Skin biopsies from affected members showed nodular subepidermal deposits (solid arrowheads) that in some fields were located immediately adjacent to arterioles (non-filled arrowheads). (I) Electron microscopy of a nodular deposit showing debris of degenerated elastica constituents (dark fragments).

mutation carriers and 1 noncarrier who had no sign of white matter disease on MRI. Amorphous deposits in the direct proximity of subcutaneous arterioles were detected in 3 affected members, probably reflecting frailty of elastic fibers with subsequent degenerative change in these small vessels. The reduced number of intraepidermal nerve fibers in 2/8 affected members may be caused by a suboptimal vascular perfusion condition. The latter cannot be proven and remains hypothetical, but we consider this to be a possible sign of systemic microangiopathy. However, other clinical features observed in affected FMs, including short stature, mild facial dysmorphism with low set, cupped ears, tremor, or dysautonomia, might also be caused by additional disease mechanisms not detected by our methods. The distribution of affected members in the pedigree and the similarity of their clinical and radiologic phenotype suggest autosomal dominant inheritance. The proband did not have any pathogenic variant in known cSVD genes in WGS, and the constellation of signs and symptoms found in this family has not previously been described to our knowledge. This suggests the disease in this family represents a novel entity.

WES analyses of 7 affected and 1 unaffected FMs and bioinformatics filtering for rare variants with deleterious impact in silico revealed 1 variant NM\_004672.4 *MAP3K6* c.322G>A p.(Asp108Asn) cosegregating with the disease. Mitogen-activated protein kinase kinase kinase 6 (*MAP3K6*, previous designation: apoptosis signal-regulating kinase 2, *ASK2*) constitutes a component of the c-Jun N-terminal kinase (*JNK*) and the p38 *MAPK* pathways, chains of highly conserved serine/threonine protein kinases that communicate signals from cell surface receptors to the nucleus, influencing gene transcription. *MAP3K6* is positioned upstream, phosphorylating on stimuli a kinase-kinase that in turn phosphorylates effector kinases, which activate specific transcription factors.<sup>15,16</sup> *MAP3K6* has been implicated in angiogenesis and tumor formation, although effects in both directions have been observed. A screen of 320 transcription factors and kinases identified *MAP3K6* as a potent regulator of VEGF expression; *MAP3K6* inhibition or knockout in cell systems downregulated VEGF expression, resulting in diminished proliferation of blood vessel endothelium and attenuated formation of capillary networks.<sup>17</sup> Signet ring cancer was associated with a heterozygous truncating *MAP3K6* mutation in the proband of a Portuguese family<sup>18</sup> and with a different mutation in *MAP3K6* in a Canadian pedigree, albeit with reduced penetrance. This suggests loss-of-function/haploinsufficiency or dominant negative pathomechanism, which would be expected to decrease VEGF expression. However, a clinical study showed that antiangiogenic therapy with monoclonal antibodies against VEGF might be particularly beneficial against signet ring gastric cancer.<sup>19</sup> Furthermore, *MAP3K6* knockdown mice lacking 1 or both copies of *MAP3K6* had no discernible phenotype under normal conditions, but showed an increased risk to develop skin papillomas on contact with the carcinogen DMAP, and this was more pronounced in homozygous than heterozygous knockdown animals.<sup>20</sup> *MAP3K6* was found to be downregulated in broilers (meat

chicken) with tibial chondroplasia, characterized by deficient angiogenesis, after exposure to the pesticide thiram, which might provide a link to the short stature in affected individuals in this family, and to vascular abnormalities.<sup>21</sup> Somatic *MAP3K6* variants have also been identified in breast and ovarian carcinomas.<sup>22</sup> The effect direction of *MAP3K6* on cancer and angiogenesis may be divergent, and it has been pointed out that *MAP3K6* interacts with *MAP3K5* (*ASK1*), forming a delicate balance of pro- and antiapoptotic effects, to regulate the rates of cell proliferation and angiogenesis.<sup>18</sup> As the 2 proteins form homo- or heterodimers, dominant negative mechanisms of pathogenic genetic variants are conceivable.<sup>16,18,23</sup>

In our study, we attempted to measure an effect of the *MAP3K6* variant on VEGF expression, comparing baseline (unstimulated) serum VEGF between carriers and matched noncarriers, but we failed to see any significant difference. We hypothesize this may be because *MAP3K6* does not markedly influence VEGF expression under normal conditions, but has a more important function in increasing VEGF production in tissue hypoxemia, for example, in response to stroke or in growing tumors, thus promoting angiogenesis.

Mutations in other genes encoding for members of the *MAPK*-*JNK*/p38 pathway are known causes of neurodevelopmental disorders, with some features reminiscent of the phenotype in the family described here. Mutations in *MAPK8IP3* (*JNK*-interacting protein 3) cause neurodevelopmental disorder with or without variable brain abnormalities, where short stature, facial dysmorphism including low-set ears, ataxia, and reduced white matter volume on MRI are observed.<sup>24,25</sup> Mutations in *PPP2CA* cause neurodevelopmental disorder and language delay with or without structural brain abnormalities, in which facial dysmorphias are reported.<sup>26</sup> Variants in *MAP3K5*, with which *MAP3K6* interacts and forms dimers, affect the risk for schizophrenia.<sup>27</sup> Mutations in the kinases of the parallel *MAPK*-Ras pathway cause the neurodevelopmental syndromes Noonan syndrome, Costello syndrome, and cardio-facio-cutaneous syndrome.<sup>28</sup>

In this study, we use published guidelines to evaluate the evidence for *MAP3K6* c.322G>A p.(Asp108Asn) being causative for the phenotype in this family.<sup>29,30</sup> The variant was entirely absent in the gnomAD database and was predicted deleterious and phylogenetically preserved, although the variant is outside the catalytic kinase domain (uniprot.org/uniprot/O95382). The variant is located in exon1 of 3 known transcripts, ENST00000374040, ENST00000493901, and ENST00000357582. These are expressed in arteries, skin, subcutaneous adipose tissue, and the cerebellum. The variant alters an exonic splicing enhancer site, potentially altering splicing.

Not all FMs whom we considered affected presented all clinical and radiologic signs of the disorder, but some degree of intrafamilial variability of expression is common for many genetic neurologic disorders. Some signs, for example, lacunes in neuroradiologic examinations, may cease to be detectable

on CT/MRI after a few years.<sup>31,32</sup> Furthermore, detection of WMH in brain imaging is a relatively common finding and may be considered nonspecific. However, the presence of a specific combination of signs and symptoms in the affected FMs and the absence of these findings in the unaffected FMs suggest a true disease entity.

The most pronounced histopathology was seen in the larger arteries and in basal ganglia penetrant arteries, and less marked changes were seen in arterioles. This can readily explain the occurrence of lacunar infarct and is also compatible with the radiologic observations of MRI WMHs.

The cosegregation analyses were based on exome and not genome data, which means that an intronic or intergenic variant may have been overlooked as the true disease cause. However, we did use whole-genome data to exclude any possible disease cause in the genes already implied in cSVD. Besides, the majority of presently known disease-causing monogenic variants are located in the exome.

Parallel sequencing analyses generate long lists of genetic variation, and the challenge lies in identifying the truly disease-associated variants from among these. A possibility to overinterpret what is already known about a gene or its product when judging a candidate gene in the pathogenesis of a particular disease remains. Genetic variation in *MAP3K6* is known to participate in angiogenesis, and this particular biological mechanism matches the pathologic changes we found in the cerebral vasculature of our patients. We do not present direct evidence from functional studies that *MAP3K6* c.322G>A p.(Asp108Asn) indeed causes cSVD.

This study describes a disease with cerebrovascular pathology that we consider novel. Formally, our data sustain only limited supportive evidence for a causal role of *MAP3K6* in this disease, according to the framework developed by Clinical Genome Resource (ClinGen),<sup>30</sup> and firm evidence for the variant's pathogenicity is still pending. However, the large size of the family described here, the distinct clinical, radiologic, and pathologic phenotype, and the exome-wide, open, hypothesis-free methods that led to its identification all make it very likely that the *MAP3K6* variant is causative.

Discovery of *MAP3K6* variants in additional probands or families with this clinical picture, and/or experimental data that more clearly support pathogenicity, will firmly establish *MAP3K6* as a causative gene for this disorder.

## Acknowledgment

The authors thank all FMs for their participation. Research nurse Karin Nilsson, PhD, contacted FMs and compiled genealogical data, and research nurse Christin Karremo organized patient visits and blood sample collection. Catharina Crammert, BSc, obtained electron microscopy images. Annika Andreasson, BSc, Gabriella Johnn, and Martin Olsson, MD, PhD, performed VEGF analyses. Viktor Henmyr, PhD,

performed bioinformatics analysis of WGS data regarding copy number variants and tandem repeats.

## Study Funding

This study was supported by The Swedish Research Council (2019-01,757), the Swedish government (under the Avtal om Läkarutbildning och Medicinsk Forskning, ALF), the Swedish Heart and Lung Foundation, Hans-Gabriel and Alice Trolle-Wachtmeister Foundation for Medical Research, Region Skåne, Lund University, Skåne University Hospital, Sparbanksstiftelsen Färs och Frosta, and Fremasons Lodge of Instruction Eos in Lund, all in Sweden.

## Disclosure

Disclosures available: [Neurology.org/NG](https://www.neurology.org/NG).

## Publication History

Received by *Neurology: Genetics* June 15, 2020. Accepted in final form November 9, 2020.

## Appendix Authors

Name	Location	Contribution
<b>Andreea Ilinca, MD</b>	Lund University, Sweden	Study concept and design, major role in the acquisition of clinical and genetics data, analysis or interpretation of data, drafting/ revising the manuscript for content, obtaining funding, and statistical analysis
<b>Elisabet Englund, MD, PhD</b>	Lund University, Sweden	Major role in the acquisition of pathology data, analysis or interpretation of pathology data, and drafting/revising the manuscript for content
<b>Sofie Samuelsson, MSc</b>	Lund University, Sweden	Major role in the acquisition of genetics data and analysis or interpretation of genetics data
<b>Katarina Truvé, PhD</b>	University of Gothenburg, Sweden	Major role in the acquisition of genetics data and analysis or interpretation of genetics data
<b>Efthymia Kafantari, MSc, MSc</b>	Lund University, Sweden	Major role in the acquisition of genetics data, analysis or interpretation of genetics data, and drafting/revising the manuscript for content
<b>Nicolas Martinez-Majander, MD</b>	Helsinki University Hospital, Finland	Revising the manuscript for content and contribution of patient samples
<b>Jukka Putaala, MD, PhD</b>	Helsinki University Hospital, Finland	Revising the manuscript for content and contribution of patient samples
<b>Claes Håkansson, MD</b>	Lund University, Sweden	Analysis and interpretation of radiology data and revising the manuscript for content
<b>Arne G. Lindgren, MD, PhD</b>	Lund University, Sweden	Revising the manuscript for content, study concept or design, study supervision or coordination, and obtaining funding



## Appendix (continued)

Name	Location	Contribution
<b>Andreas Puschmann, MD, PhD</b>	Lund University, Sweden	Major role in the acquisition of data, study concept or design, analysis or interpretation of data, study supervision or coordination, and obtaining funding

## References

- Seshadri S, Beiser A, Pikula A, et al. Parental occurrence of stroke and risk of stroke in their children: the Framingham study. *Circulation* 2010;121:1304–1312.
- Lindgren A. Stroke genetics: a review and update. *J Stroke* 2014;16:114–123.
- Low WC, Junna M, Borjesson-Hansson A, et al. Hereditary multi-infarct dementia of the Swedish type is a novel disorder different from NOTCH3 causing CADASIL. *Brain* 2007;130:357–367.
- Marini S, Anderson CD, Rosand J. Genetics of cerebral small vessel disease. *Stroke* 2020;51:12–20.
- Pantoni L. Cerebral small vessel disease: from pathogenesis and clinical characteristics to therapeutic challenges. *Lancet Neurol* 2010;9:689–701.
- Ilinca A, Samuelsson S, Piccinelli P, Soller M, Kristofferson U, Lindgren AG. A stroke gene panel for whole-exome sequencing. *Eur J Hum Genet* 2019;27:317–324.
- Das AS, Regenhardt RW, Vernooij MW, Blacker D, Charidimou A, Viswanathan A. Asymptomatic cerebral small vessel disease: insights from population-based studies. *J Stroke* 2019;21:121–138.
- Nasreddine ZS, Phillips NA, Bedirian V, et al. The Montreal Cognitive Assessment, MoCA: a brief screening tool for mild cognitive impairment. *J Am Geriatr Soc* 2005;53:695–699.
- Genomes Project C, Auton A, Brooks LD, et al. A global reference for human genetic variation. *Nature* 2015;526:68–74.
- Ameur A, Dahlberg J, Olason P, et al. SweGen: a whole-genome data resource of genetic variability in a cross-section of the Swedish population. *Eur J Hum Genet* 2017;25:1253–1260.
- Lek M, Karczewski KJ, Minikel EV, et al. Analysis of protein-coding genetic variation in 60,706 humans. *Nature* 2016;536:285–291.
- Ilinca A, Martinez-Majander N, Samuelsson S, et al. Whole-exome sequencing in 22 young ischemic stroke patients with familial clustering of stroke. *Stroke* 2020;51:1056–1063.
- Pourhamidi K, Dahlin LB, Englund E, Rolandsson O. Evaluation of clinical tools and their diagnostic use in distal symmetric polyneuropathy. *Prim Care Diabetes* 2014;8:77–84.
- Ekman L, Thrainsdottir S, Englund E, et al. Evaluation of small nerve fiber dysfunction in type 2 diabetes. *Acta Neurol Scand* 2020;141:38–46.
- Wang XS, Diener K, Tan TH, Yao Z. MAPKKK6, a novel mitogen-activated protein kinase kinase kinase, that associates with MAPKKK5. *Biochem Biophys Res Commun* 1998;253:33–37.
- Takeda K, Shimozono R, Noguchi T, et al. Apoptosis signal-regulating kinase (ASK) 2 functions as a mitogen-activated protein kinase kinase kinase in a heteromeric complex with ASK1. *J Biol Chem* 2007;282:7522–7531.
- Eto N, Miyagishi M, Inagi R, Fujita T, Nangaku M. Mitogen-activated protein 3 kinase 6 mediates angiogenic and tumorigenic effects via vascular endothelial growth factor expression. *Am J Pathol* 2009;174:1553–1563.
- Gaston D, Hansford S, Oliveira C, et al. Germline mutations in MAP3K6 are associated with familial gastric cancer. *Plos Genet* 2014;10:e1004669.
- Fuchs CS, Tomasek J, Yong CJ, et al. Ramucirumab monotherapy for previously treated advanced gastric or gastro-oesophageal junction adenocarcinoma (REGARD): an international, randomised, multicentre, placebo-controlled, phase 3 trial. *Lancet* 2014;383:31–39.
- Iriyama T, Takeda K, Nakamura H, et al. ASK1 and ASK2 differentially regulate the counteracting roles of apoptosis and inflammation in tumorigenesis. *EMBO J* 2009;28:843–853.
- Jahejo AR, Niu S, Zhang D, et al. Transcriptome analysis of MAPK signaling pathway and associated genes to angiogenesis in chicken erythrocytes on response to thiram-induced tibial lesions. *Res Vet Sci* 2019;127:65–75.
- Guo H, Zhou H, Lu J, Qu Y, Yu D, Tong Y. Vascular endothelial growth factor: an attractive target in the treatment of hypoxic/ischemic brain injury. *Neural Regen Res* 2016;11:174–179.
- Ortner E, Moelling K. Heteromeric complex formation of ASK2 and ASK1 regulates stress-induced signaling. *Biochem Biophys Res Commun* 2007;362:454–459.
- Iwasawa S, Yanagi K, Kikuchi A, et al. Recurrent de novo MAPK8IP3 variants cause neurological phenotypes. *Ann Neurol* 2019;85:927–933.
- Platzer K, Sticht H, Edwards SL, et al. De novo variants in MAPK8IP3 cause intellectual disability with variable brain anomalies. *Am J Hum Genet* 2019;104:203–212.
- Reynhout S, Jansen S, Haesen D, et al. De novo mutations affecting the catalytic alpha subunit of PP2A, PPP2CA, cause syndromic intellectual disability resembling other PP2A-related neurodevelopmental disorders. *Am J Hum Genet* 2019;104:139–156.
- Luan Z, Sun Y, Li Y, Ming W, Zhang Y. Genetic association of the human MAP3K5 gene with schizophrenia in a Chinese Han population. *Psychiatr Genet* 2019;29:26–27.
- Tajan M, Paccoud R, Branka S, Edouard T, Yart A. The RASopathy family: consequences of germline activation of the RAS/MAPK pathway. *Endocr Rev* 2018;39:676–700.
- MacArthur DG, Manolio TA, Dimmock DP, et al. Guidelines for investigating causality of sequence variants in human disease. *Nature* 2014;508:469–476.
- Strande NT, Riggs ER, Buchanan AH, et al. Evaluating the clinical validity of gene-disease associations: an evidence-based framework developed by the clinical genome resource. *Am J Hum Genet* 2017;100:895–906.
- Wardlaw JM, Smith EE, Biessels GJ, et al. Neuroimaging standards for research into small vessel disease and its contribution to ageing and neurodegeneration. *Lancet Neurol* 2013;12:822–838.
- van Leijns EMC, de Leeuw FE, Tuladhar AM. Disease progression and regression in sporadic small vessel disease—insights from neuroimaging. *Clin Sci (Lond)* 2017;131:1191–1206.