

# How Everyday Counterfeit Behavior That Disrupts Self Authenticity Might Lead to Corruption Tendencies

Juneman Abraham <sup>1</sup>, Tommy Prayoga <sup>2</sup>, Kharisma Murti <sup>3</sup>, Afifah Azizah <sup>4</sup>,  
Nathasya Shesilia Krishti <sup>5</sup>, Sheila Putri Fajrianti <sup>6</sup>, Bernadette Nathania Octaviana <sup>7</sup>,  
Wing Ispurwanto <sup>1</sup>, Rudi Hartono Manurung <sup>8</sup>

<sup>1</sup>Psychology Department, Faculty of Humanities, Bina Nusantara University, Jakarta, 11480, Indonesia; <sup>2</sup>Content Collision, Jakarta, 11470, Indonesia; <sup>3</sup>Indonesia's Country Marketing Department, Carousell, Singapore, 139234, Singapore; <sup>4</sup>GEO Business and Strategy Department, Whisper Media, Jakarta, 10270, Indonesia; <sup>5</sup>Master's Program in Adult Clinical Psychology, Atma Jaya Catholic University of Indonesia, Jakarta, 12930, Indonesia; <sup>6</sup>Student Support Division, Multimedia Nusantara University, Banten, 15810, Indonesia; <sup>7</sup>Group Instruction Department, Celebrity Fitness Indonesia, Jakarta, 12310, Indonesia; <sup>8</sup>Japanese Department, Faculty of Humanities, Bina Nusantara University, Jakarta, 11480, Indonesia

Correspondence: Juneman Abraham, Tel +62 21 5345830, Fax +62 21 53674042, Email juneman@binus.ac.id

**Background:** In the field of moral psychology, researchers have strived to understand the complex dynamics of corruption psychology. This study contributes to this area by presenting a theoretical model for sequential behavior, placing counterfeit behavior (CB) as a predictor and corruption tendencies (proneness to moral emotions, ie, guilt and shame/GASP) as the criterion. In addition, two bridging variables are assigned, ie, inauthenticity/counterfeit self (CS) and moral disengagement (MD).

**Methods:** The research applied a correlational-predictive design and mediation analysis. Study 1 involved 978 participants of Indonesian nationality (380 males, 598 females;  $M_{age} = 23.64$  years old,  $SD_{age} = 4.35$  years), and found that GASP was predicted by MD, and MD was predicted by CS. Study 2, which applied a between-subject design, showed that CS was predicted by four kinds of everyday counterfeit behavior (backstabbing, fake listening, plagiarism, and religious hypocrisy).

**Results:** The hypotheses of Study 1 and Study 2 were confirmed by the data analysis. By integrating both studies, this study advocates the view of moral consistency through variable configuration (ie moral emotions, self and behavior authenticity, moral engagement) that composes corruption tendencies – which to the best of the author's knowledge, has not been proposed in other studies.

**Conclusion:** The novelty contained in the variable network is that counterfeiting, which is present in our daily life and considered to be ordinary and inevitable in the 4.0 Industry era, has a critical disrupting implication towards a person's morality.

**Keywords:** psychology of corruption, corruptive tendency, inauthentic behavior, fake culture, counterfeit self, moral disengagement

## Introduction

Our daily lives are no longer free from disruption, particularly digital disruption, brought by technology. In this context, disruption is a process in which newcomers with few resources can successfully disrupt incumbents by utilizing information-based assets and pursuing an exponential price-performance trajectory. This can be evaluated on three levels of effects: disturbance, distortion, and market dominance.<sup>1</sup> Technology disruption results in discontinuity of previous products, services and/or processes.<sup>2</sup> The high scalability of disruptions means intense competition and eradication of traditional ways of serving demands. Technology disruptions act as a two-edged sword. On one hand, they can provide accessibility, efficiency, and affordability for people and their needs. They also help companies map out users' demographics and psychographics to understand their stakeholders better and eventually create solutions to solve their problems. On the other hand, data is susceptible to unethical exploitations. Essentially, such disruptions have caused a tiered socio-economic change that has affected specific parties involved in research and development, firms, industries,

consumers, authorities, as well as society at large.<sup>3</sup> Whether they are willing to or not, these parties must reconsider their strategy to sustain in this mature economic disruptive condition.

Psychologically speaking, disruption is facilitated by five types of perceptions,<sup>2</sup> ie, (1) Innovation trigger – when a technical innovation becomes widely known, it piques public attention and raises expectations about its potential; (2) Peak of inflated expectations – service providers introduce items for innovators and early adopters, generating enthusiasm and a sense of needing to be a part of it or be left out; (3) Disillusionment trough – early achievements do not result in the expected advantages, and media attention shifts to focusing on the problems rather than the potential of the invention; (4) Slope of enlightenment – early adopters begin to reap the benefits, knowledge about how to successfully innovate with technology developments, and best practices emerge; and (5) Productivity plateau – advantages are shown and risks of innovation are reduced, resulting in widespread adoption with productive and usable value.

As is evident from the five facilitating perceptions mentioned above, in order to optimize the psychological disruption process, people require a *coping strategy* when dealing with technological disruption. As stated by Kamble,<sup>4</sup> coping strategies are needed to shatter deep-seated myths and alleviate people’s fears of technology. Notwithstanding this, it appears that Kamble assumes that most people are reluctant to adapt to the reality of disruption. He stated that

People naturally resist change. Technology changes fast but it takes generations to change the minds and behavior of humans. I call it the ‘inertia of the human mind’<sup>4</sup> (p. 3).

The aforementioned symptoms are termed *adaptation deficits toward disruption*. In reality, however, other symptoms have yet become Kamble’s<sup>4</sup> focus, namely other forms and directions of adaptation, known as *adaptation surplus towards disruption*.

Eggers and Park<sup>5</sup> elaborated on the implications of adaptation. Adapting to technology disruption is a process that involves possession, acquisition, assimilation, and reconfiguration of certain behaviors. Although this explanation is on an organizational level, it is also applicable on an individual level. It is a *positive* form and direction of the adaptation process toward technology disruption. Adaptation is a learning process. In terms of this, however, the challenges would entail pretension and lack of critical understanding, response, treatment, and living with disruption as a social phenomenon.<sup>6</sup> As mentioned by Riemer<sup>6</sup> (section “Transcript: How we adapt to digital disruption”):

“[What should young people be doing who are listening to this podcast right now and are hearing us talk about digital disruptions, how do they prepare for a world of digital disruptions?]

Yeah so, we hear a lot about the uncertainty, ambiguity, volatility that we see in markets.

So, how do you prepare for a rapidly changing world that is full of technology that you know ... threatens us with automation, artificial intelligence? It’s a good question.

I think people need to learn how to learn, right? And I think that’s what we do in universities is we do not necessarily just impart knowledge and then *pretend that this is the knowledge*, that’s all you need right? Go out there and you know everything and can do everything.”

The views put forward by Riemer<sup>6</sup> are relevant nowadays. *Pretension* is a rampant symptom of technology disruption that exists at this day and age, and is an *excessive result of the surplus of adaptation*. Such excess even appears to be subconscious and is institutionalized. In clinical psychology, pretension is a form of maladaptive behavior in this “selfie-culture” era. As stated by Schade et al<sup>7</sup> (para. 12), “Individuals high in grandiose narcissism show high levels of adaptive and maladaptive behavior, making them pretentious, conceited, and exhibitionistic.” Meanwhile, we are now faced with the fact that the culture in our society is becoming increasingly narcissistic.<sup>8</sup> “Rather than fostering a renaissance, it [Internet] has created a selfie-centered culture of voyeurism and narcissism”<sup>9</sup> (p. ii); it is as if this culture cannot be avoided. In this decade of information maturity, Wognum et al<sup>10</sup> mentioned that counterfeits or pretension are considered “trade-offs in knowledge exchange” (p. 17).

Falling under the same category as counterfeiting, fake news and deep-fake are some examples of the process and product of maladaptation towards technology disruption. These examples are not merely symptoms of resistance to, or deficit of, adaptation as put forward by Kamble.<sup>4</sup> They are in fact symptoms of appropriating technology disruption to benefit one's self or one's group at the expense of others, which is considered to be another form and direction of the adaptation process. The consequences of maladaptation are far from simple and may in turn create complications in our daily life. Chesney and Citron<sup>11</sup> (p. 1754) described this as follows:

While deep-fake technology will bring certain benefits, it also will introduce many harms. The marketplace of ideas already suffers from truth decay as our networked information environment interacts in toxic ways with our cognitive biases. Deep fakes will exacerbate this problem significantly.

Cahr and DeBella<sup>12</sup> (para. 3) reiterated the words of Marx to illustrate the consequences of maladaptation, "Who ya gonna believe, me or your own eyes?". This reflects the capacity of contemporary developments like augmented reality, social media, Artificial Intelligence-powered editing tools, bots, influencer campaigns, and immersive advertising to erode core ideas of "truth".<sup>12</sup> In this present study, the symptom is called "fake culture", whereas FranklinCovey<sup>13</sup> termed it as "counterfeit culture". Counterfeit behavior may appear to be effective or useful considering the rise of such counterfeit culture, and as such, it is frequently accepted in the community. It is also prevalent in many sectors, organizations, and societies (Covey, as cited in Green<sup>14</sup>).

This present study was conducted based on the assumption that fake behavior and culture - as a strategy that is thought to be effective in coping with various disruptive changes brought on by technology - have become an identity narrative in the current daily lives of many. This implies that counterfeit behavior and culture have become a central topic in many people's life stories that describes how their past is intertwined with the present and projected future.

This research focuses on the results of various counterfeit behaviors that can be predicted. FranklinCovey<sup>13,15</sup> identified several forms of counterfeit behaviors which among others include (1) withholding information, (2) faking respect or concern, (3) having hidden agendas, (3) disguising, (4) being two-faced, (5) fake work, (6) making a big show of efforts to improve, yet failing to follow through, and (7) pretending to listen. All of these behaviors are similar in the way that they are presented as trustworthy or honest behaviors when they are in fact the opposite. False listening, for example, would appear like genuine listening. It provides the appearance that the person exhibits trustworthy behavior, although such behavior is not genuine or sincere. FranklinCovey<sup>16</sup> described counterfeiting in the disruption era as follows:

Interestingly, during major disruptions, leaders tend to drift not to the opposite of a high-trust behavior, but to the counterfeit .... The counterfeit is to act like we're confronting reality when we're actually evading it. We might focus on busywork or ancillary issues instead of tackling the tough root causes of the challenges at hand. We kick the can down the road. We skirt reality or give lip service to it, versus facing the hard news that it's bad now and it may get worse.

Counterfeiting is considered an unethical behavior that carries certain consequences. Frequently, these consequences are not properly considered, not realized, or are even intentionally disregarded or willfully ignored, referred to as ethical cost.<sup>17</sup> This implies that essentially, counterfeiting may erode morality. The problem is that counterfeit behavior may disguise itself as trust behavior, which is in line with societal etiquette and politeness. As stated by Frost<sup>18</sup> (p. 13), "Etiquette, it is sometimes urged, is used to cloak what is hollow, unmeaning and false." This type of behavior may potentially result in a counterfeit self,<sup>17</sup> which may in turn influence moral disengagement and corruption tendencies.<sup>19</sup>

## Corruption Tendency in a Counterfeit Culture

The relationship between counterfeiting and corruption is worth studying given the prevalence of this moral transgression that is currently faced in Indonesia and many other developing countries. Corruption is an act of abusing power for personal gain.<sup>20</sup> However, it is rarely done only once, and its widespread practice turns it into a "cultural" phenomenon of dishonesty that causes financial, social, and ethical harms on a large scale.<sup>21</sup> Most studies discuss corruption as a phenomenon and as a product. The process, specifically the psychological dynamic that leads to it, is not often

reviewed. This is understandable as Moore<sup>22</sup> once stated that corruption serves as a dynamic process that is difficult to be empirically captured.

Studies tend to explore the tangible causes of corruption such as legal loopholes, lack of monitoring, and perhaps the issue of wealth that money yields. Although this is a valid perspective, another important factor to consider is the individuals themselves. Corruption does not occur when the opportunity presents itself, but rather when the opportunities are acted upon. This viewpoint reveals that (1) the responsibility to not engage in corruption is shifted towards the person instead of the system, and (2) human emotions such as guilt, act as a tool that alerts us when our morality faces a threat.<sup>23</sup> This will then filter the cognitive dissonance and produce a decision to engage in corruption or not. The *Minimal Justification Hypothesis*<sup>24</sup> explains that an individual's attitude can be changed by incentivizing counter-attitudinal behavior (in this present study's context: counterfeit behavior). As an act, when corruption often yields financial or material reward it will likely change the individual's attitude towards the corruption without creating dissonance, thus kickstarting the journey to disengage moral values when it comes to performing an act of corruption.

Although attempts to generate a deeper understanding of corruption has been done in the past few years in Indonesia, academic disparity in the field of moral psychology still exists due to the lack of robust evidence that elaborates the psychological dynamics of corruption viewed from a "common behavior" perspective, which may be a result of counterfeit culture. This study aims to clarify how daily counterfeit behavior has a domino effect on an individual's corruption tendency. Because measurement of corruption will explicitly produce biased responses - considering the high rate of social desirability (people tend to say that they are not corrupt, because corruption is a legal violation) - this study applied a corruption tendency measurement (moral emotions proneness), and not the act of corruption itself.

Previous studies have empirically proven that there is a negative correlation between proneness to moral emotions (in the form of guilt and shame) and corruption.<sup>25</sup> In terms of measurement, Cohen et al<sup>26</sup> (p. 947) also mentioned that

The Guilt and Shame Proneness Scale has the potential to be an important measurement tool for detecting individuals susceptible to corruption and unethical behavior.

However, the *antecedent of proneness to moral emotions* has yet to be discovered. This elaboration is necessary to provide insight into the dynamics of corruption psychology. This study places proneness as a dependent variable, and counterfeit behavior as the initial antecedent of corruption tendencies. Based on the statements proposed, this research aims to investigate how counterfeit behavior may predict corruption tendencies in the form of proneness to guilt and shame.

## Everyday Counterfeit Behavior Triggers Moral Behavior Dynamics

The author hypothesized that performing everyday unethical behavior may serve as a slippery slope towards bigger, morally disengaged behavior such as corruption.<sup>22</sup> To demonstrate the slippery slope, Gino et al<sup>27</sup> conducted three experiments to assess the effect of using counterfeit products on (1) the participants' ethical behavior, (2) their perception of other people's ethical behavior, and (3) the psychological mechanism behind the emergence of unethical behavior. The result showed that (1) individuals who showed a preference for counterfeit products exhibited dishonest behaviors (ie, cheating) in various tasks; (2) participants in counterfeit conditions perceived other people's behavior to be more dishonest and unethical and believed that people show less truthful actions through common excuses; (3) when self-alienation (an unfavorable aspect of authenticity) was included within the analysis - it served as a significant predictor of dishonesty such that usage of counterfeit products brings about feelings of inauthenticity (ie, inauthentic/counterfeit self) which eventually leads or extends to other unethical behavior (ie, exhibited as cheating behavior in this experiment).

To illustrate a theoretical model, the psychological process of unethical behavior proposed by Gino et al<sup>27</sup> is as follows:

Everyday counterfeit behavior (using counterfeit products) → Inauthenticity → Immorality (Unethical Behavior) ....  
(MODEL 1)

This present study views that the research model proposed by Gino et al<sup>27</sup> should be expanded to provide a more comprehensive illustration of the dynamics of moral behavior. One way to demonstrate this is by integrating the model

with a related model obtained from existing literature. The model proposed by Knoll et al<sup>28</sup> closely relates to the research model by Gino et al.<sup>27</sup> The model can be depicted as follows:

Authenticity → Moral disengagement → Unethical behavior .... (MODEL 2)

The model included situational strength as a moderator variable between moral disengagement and unethical behavior. However, because this study focuses on intrapsychic dynamics, the situational variable is not taken into account as an explicit variable. Integration of MODEL 1 and MODEL 2, therefore, produces the following theoretical model:

Everyday counterfeit behavior → Inauthenticity → Moral disengagement → Unethical behavior .... (MODEL 3)

Moreover, MODEL 3 is elaborated following the purpose of this study to explain *corruption as a particular form of unethical behavior*. In consideration of the challenges of measuring acts of corruption as mentioned in the *Corruption Tendency in a Counterfeit Culture* section, this study measures corruption tendencies through guilt and shame proneness (GASP) as a dependent variable.

Having proneness to moral emotions (guilt and shame) means that the person is aware of the moral transgression of their actions, and they possess the inclination to do otherwise. It is a sign that the person is behaving inconsistently about his/her own true beliefs, living the inauthentic, or counterfeit version of themselves.<sup>29</sup> Existentially, moral emotion is a reminder that a person is detached from their moral ground and their true authentic self.

Additionally, this present study applies various forms of everyday counterfeit behavior apart from the use of counterfeit products. As such, MODEL 3 was expanded into:

Everyday counterfeit behavior → Inauthenticity/counterfeit self → Moral disengagement → Guilt and shame proneness (Corruption tendency) .... (MODEL 4)

In MODEL 4, as the focus of this part of the study, it is clear that everyday counterfeit behavior can be considered the source of corruption tendency that can trigger two psychological processes, being inauthenticity/counterfeit self and moral disengagement, which leads to corruption tendency.

## Moral Emotions (Guilt and Shame) Proneness Can Be Predicted by Moral Disengagement

The process of engaging with one's morality and personal standards is guided and shaped by moral emotions. Our proneness (or conversely resistance) to these moral emotions determines our moral stance in performing deviant and corruptive behavior. The emotions facilitate the attainment of complex social goals and solve complex social, dilemmatic problems. The emergence of these self-conscious emotions brings conciliation and avoidance when social clashes occur (eg, rejection from social groups) or when social norms have been violated (ie, feeling of guilt emerges).

When taken into a cultural context, the sense of guilt caused by norm violations may have fatal repercussions. For instance, the suicide of public figures in Japan (eg, Japan's previous Agriculture Minister, Toshikatsu Matsuoka) and South Korea (eg, Sung Wan-Jong, the construction tycoon)<sup>30-32</sup> comes from the guilt and shame not only from the corruption they committed but also from public humiliation whereby they are seen as criminals, and the idea that people they are affiliated to are family and friends of a criminal.

Regarding corruption behaviors studied in this paper, the authors focused on guilt and shame as the two main emotions to be discussed.<sup>33-35</sup> They are more complex than our basic emotions such as joy or fear that are not considered or factored in the contextual stimulus. Fear can be triggered in the presence of danger, but guilt and shame come after a deviant deed is reflected in the socio-relational context (eg, as an Indonesian, as a woman, employee of the organization, etc.). The moral emotions serve as an assessment of what part of the self is revealed (eg, our character, our worth, etc.), thus determining our moral intention, and finally behavior. Resisting the emergence of these emotions detaches the self from morals. Anticipated moral emotions are inferred from past experiences or situations that bring the same responses, whereas consequential moral emotions emerge when an individual has undergone the experience. An individual is predisposed to experience these emotional states,<sup>36</sup> which is termed *proneness of moral emotions* (ie, shame proneness, guilt proneness; Cohen et al<sup>26</sup>).

Guilt arises when an individual evaluates or attributes his/her own behavior to certain norms, instead of the overall evaluation of the self.<sup>37</sup> When the attribution to the behavior is negative, it elicits negative feelings that motivate individuals to right their wrongs or avoid doing it altogether. It stems from the regret of violating one's own morality and conscience. Guilt may also occur privately when individuals sense regret, condemnation, and a desire to compensate (repair) the behavior when personal transgression occurs.<sup>26</sup> Therefore, proneness to guilt can be measured based on these two aspects: Negative Behavior Evaluation (Guilt-NBE) and Repair (Guilt-REP) tendencies.

Shame arises when an individual evaluates or forms attributions about one's self. These evaluations bring negative feelings about one's representation of the self. As realization emerges, individuals will likely detach themselves from the situations associated with the shameful act to protect their moral identity. For example, an employee who was caught stealing from a company might decide to resign and reverse the consequence of their action, or disappear and neglect their responsibilities<sup>26</sup> to show that they are no longer associated with the positions they have wronged. Shame may also be triggered by external factors, such as when an individual experiences public humiliation or degradation when their faults are exposed (or potentially exposed) to the public.<sup>26</sup> Based on these premises, proneness to shame can be measured based on two aspects: Negative Self Evaluation (Shame-NSE) and withdrawal (Shame-WIT) tendencies.

The standpoint of this study views that when individuals behave in ways that are morally disengaging, it may lower self-censure that is usually generated by moral emotions (ie, guilt and shame) as a reaction towards internal violations.<sup>38</sup> The psychological mechanism is as follows: When people justify their inconsistent behaviors based on their personal moral standards, such justifications may cause disengagement (to validate their wrongdoings).<sup>38,39</sup> From a cognitive standpoint, moral disengagement is the result of eight cognitive mechanisms that facilitate and justify unethical or deviant behaviors.<sup>37</sup> They are (1) moral justification; (2) euphemistic labeling; (3) palliative or advantageous comparison; (4) displacement of responsibility; (5) diffusion of responsibility; (6) distortion of consequences; (7) dehumanization; and (8) blaming the victim or attribution of blame.<sup>17,19</sup>

A study conducted by Moore et al<sup>37</sup> showed that lower moral engagement predicts morally disengaged behaviors, such as fraud, forging documents, and defamation. This is true especially in the context of behaviors that are externally influenced,<sup>40</sup> such as financial fraud and corruption, as their influence facilitates detachment from one's authentic self by acting as a subject of reference in justifying morally disengaged behaviors.<sup>41</sup>

Despite the studies that connect moral disengagement (MD) and immoral behavior, the theoretical complexity of corruption warrants further examination on its psychological mechanism. Johnson and Connelly<sup>42</sup> through their empirical study found that moral disengagement has a negative correlation with guilt ( $r = -0.46, p < 0.01$ ) and shame ( $r = -0.14, p < 0.05$ ); although they did not separate the traits of guilt into Guilt-NBE and Guilt-REP or the traits of shame into Shame-NSE and Shame-WIT. This negative correlation is logical because personal responsibility and reparative actions are connected with shame and guilt. Meanwhile, moral disengagement has opposing characteristics from guilt and shame, in a way that the significance of danger emerging from violation of moral standards diminishes when a person is morally disengaged. Any guilt or shame resulting from this internal moral struggle will be eliminated via moral disengagement tactics.<sup>43</sup>

Therefore, the first hypothesis (H1) of this study is: the higher the moral disengagement, the lower the guilt and shame proneness.

## Moral Disengagement Can Be Predicted by Inauthentic/Counterfeit Self

Acting in a manner that is not following the authentic self will drive a person further away from their morality (ie, moral disengagement).<sup>28</sup> As we use personal and social values to make sense of the world, these values become the fundamental principles of our beliefs.<sup>44</sup> Having and holding on to these values provide us with the sense of authenticity in defining our selves (ie, reflecting our authentic self), as they are essentially virtuous. In support of this, research by Newman et al<sup>44</sup> suggested that changes in the agent's behavior from a morally bad state to a morally good state is attributed to the "true self" (ie, authentic self), whereas the opposite is attributed towards the "surface self" or "false (counterfeit) self".

Authenticity of the self is manifested as the congruency between cognition, effect, needs, and desires with real world experiences in daily life.<sup>45</sup> It is related to Carl Rogers' (as cited in Schmid<sup>46</sup>) concept of being congruent or the

genuineness that we exhibit to the world that reflects our values. Such genuineness can be indicated by the values a person holds, ie what they believe is right or wrong and how it is displayed in their behavior.

Newman et al<sup>44</sup> concluded that within every individual, there is a “true self” motivating him or her to behave in virtuous ways. However, it is also necessary to understand the differences in the values that individuals hold, to truly grasp the conceptualization of their “true self”. Inauthenticity, on the other hand, is when such congruence is not being displayed or hidden. It comes with a feeling of impurity.<sup>45</sup>

The implications of inauthenticity are lack of awareness, ignorance, distortion, as well as an oversimplification of one’s self-knowledge and moral standards.<sup>47</sup> A person living inauthentically is considered showcasing their counterfeit self. Inauthenticity alienates a person from their true and authentic sense of self<sup>48</sup> which encompasses many aspects of life, such as moral judgment, moral assessments of others’ beliefs about the meaning of life, moral decision making, even general measures of well-being.<sup>49</sup>

Thus, the second hypothesis (H2) of this study is: the stronger the inauthentic/counterfeit self in an individual, the higher the moral disengagement.

## The Contribution of the Present Study: The Role of Counterfeit Behavior

Based on the logic model described above (summarized as MODEL 4), analyzing the sense of self in the context of corruption will tell us not only how these components drive corruptive behaviors, but more importantly the process that precedes, and then leads to the tendency for corruption. It provides insights into how the sense of self decides to engage or not engage in corrupt behaviors in the face of opportunities.

The majority of prior studies on corruption that are conducted on an individual level mostly focuses on aspects that act as predispositions in an individual, or the psychological factor that would predict an individual’s tendency to engage in corruption. However, the relations between these predispositions and behavior (*self* → *behavior*) is complex, as both may influence one another. To the best of the author’s knowledge, there have not been many studies that focus on the influence of unethical behavior on the whole self (*behavior* → *self*), as conducted by Gino et al<sup>27</sup> with existing literature focusing on merely the moral cost and considerations of engaging in such behavior.

In line with the *behavior* → *self* study, to predict the occurrence of corruption behavior, this study posits that we should begin by studying everyday counterfeit behavior with similar basic characteristics as corruption. This is based on the prior understanding that in its nature, corruption is cumulative and progressive and emerges from day-to-day experiences.<sup>50,51</sup>

For example, a salesperson may want to look good in front of a prospective customer by claiming exaggerated benefits of what they are selling. A subordinate might dislike the new boss and gossip behind her back but claims that other people started the rumor. These are behaviors acted out to maintain the person’s image.<sup>40</sup> If a person is intensively involved in this type of behavior, they are prone to inauthenticity. He or she would be capable of carrying out such morally disengaged behaviors and also ignore their moral emotions even though they know it is not right. It can therefore be said that this person is living inauthentically, as opposed to living authentically - a state of living that results from expressing emotions and behavior in a manner that is consistent with the person’s own moral belief. When these behaviors are continued and primed, feelings will be easier to cope with and the behaviors will be carried out more often and even extend to other behaviors,<sup>52</sup> often in more extreme and severe forms.

Therefore, the third hypothesis (H3) of this study is: the more intense the everyday counterfeit behavior of an individual, the higher the inauthentic/counterfeit self.

## The Four Kinds of Counterfeit Behavior Predicting Inauthenticity

This research investigates four kinds of everyday counterfeit behavior, namely (1) backstabbing, (2) plagiarism, (3) fake listening, and (4) religious hypocrisy. The four kinds of behavior selected in this study are closely related to technological disruption. Firstly, backstabbing is a byproduct of competitiveness that is caused by the advancement of technology whereby people compete for being in the “first place” even if it requires betrayal.<sup>53,54</sup> In this 4.0 Industry era, backstabbing is closely associated with a silo mentality<sup>55</sup> at the individual and organizational level. Secondly, plagiarism is unethical counterfeit behavior that is facilitated by digital disruption,<sup>56</sup> emerging along with the invention of the

internet browser feature as well as online tools, which has facilitated the theft of written work that an individual would then claim to be their own. Some may go to the extent of out-maneuvering similarity checker software to avoid getting caught. Thirdly, fake listening is also prevalent in the era of disruption, as people try to be more productive by multitasking, but not being mindful when listening to friends, peers, and clients. Meanwhile, these same people aspire to have the image of a good listener. Furthermore, listening activities are now increasingly being delegated to technology.<sup>57</sup> Lastly, the various forms of hypocrisy, including religious hypocrisy, is exacerbated by various modern technology. As put forward by Anton<sup>58</sup> (p. 120), in this era of rapid technological change that offers more pluralism and ethical diversity, “dominant communication technologies precipitate and give substance to various kinds of hypocrisy awareness.”

### Backstabbing

The first concern explores the relationship between backstabbing tendencies and the inauthenticity of the self. Backstabbing occurs when an individual is actively trying to cause harm to another individual but without the knowledge of the other person, often because the unethical behavior is masked with a neutral or harmless image. Backstabbing most often occurs between coworkers, which is a strategic action by an employee to get a “leg up” on their colleagues.<sup>59</sup> Another form comes in the context of peer relationships, which occurs between close friends.<sup>60</sup>

Backstabbing is a complex behavior as it reflects the inconsistencies in the relationship between value and behavioral intention across contexts. In front of the public or the subject target, the value displayed is aligned with the person’s behavioral intentions and behaviors (eg, promising a colleague to put in good words in front of the new boss). However, when the target subject is not present, the opposite behavior is performed (eg, pointing out all the mistakes the colleague made in front of the new boss). Note that the actual behavior is inconsistent with the positive value that is deliberately displayed to conceal the actual behavior. This deliberateness (going out of one’s own way to target a specific person) of showing positive value and behavioral intention is the key element to backstabbing, as painting a bad picture of a co-worker that a person is’ not on good terms with, however unethical, is not considered backstabbing behavior. Other key elements in backstabbing are false accusations, blame, discrediting others, taking credits for others’ works, dishonesty, slander, aggression/hostility, personal image maintenance, and self-serving.<sup>59–62</sup> These processes reflect the inauthenticity of the person performing backstabbing.

### Plagiarism

The second concern explores the relationship between plagiarism tendency and the inauthenticity of the self. Plagiarism can be defined as taking another’s idea (ideological plagiarism) or body of work (explicit plagiarism) and presenting it as one’s own.<sup>63</sup> The “others” referred to here can also include the person itself (self-plagiarizing).

The concept of plagiarizing is similar to purchasing or distributing counterfeit products. By plagiarizing, an individual presents another’s ideas as theirs. Regardless of the content, it is fundamentally an idea “advertised” by a counterfeit source. Plagiarizing depicts the “no harm no foul” nature of buying counterfeit products. As the behavior is not carried out to cause harm (unlike backstabbing) and mostly only for personal gain, the negative impacts may often be overlooked.

Plagiarism is facilitated further by the technology and social media practice of the digital era.<sup>64</sup> Sharing content or retweeting is one thing, but retrieving an online content, cropping the source, placing a personal watermark, and posting it online to gain traction and earn money is considered plagiarism. This is how an internet meme influencer Elliot Tebele (as cited in Statt<sup>65</sup>) built his audience on Instagram and was caught in the controversy.

Although plagiarism may be vague and practiced in a grey area, the attitude (behavioral tendency) towards the idea of plagiarism is not. An individual might not know the term plagiarizing, but deliberately lying about one’s own originality of idea or body of work is something that can be immediately distinguished as wrong and unethical. In other words, attitudes reveal how individuals perceive plagiarism and its dilemma, such as the justification, penalty, and factors that cause it.<sup>66</sup> Thus, measuring plagiarism tendency as a psychological factor is the best way to showcase an individual’s authenticity and tendency to act on corruption.



## Fake Listening

The third concern explores the relationship between fake listening and the inauthenticity of the self. Fake listening, or pseudo-listening, is an act of appearing to be an audience to an informant, while not actually absorbing any of the information given. It is an act of pretending to listen,<sup>67</sup> while not giving a relevant response to the information heard. Fake listening can happen in all kinds of conversational settings. For example, a colleague might nod and mumble in agreement when listening to a presentation, but he or she may be thinking about other things.<sup>68</sup> Someone may give responses to certain questions but is actually playing with their phone.<sup>69</sup> Certain body language can be observed as a sign of pseudo-listening, such as not being able to focus on the speaker, playing with fingers, impatience, shaking of body parts, and rushing affirmations. Fake listening can occur even when the speakers and the listeners are not engaged in face-to-face communication, as it can also happen in text or phone calls.<sup>70</sup> Finally, if a person is an audience to a speaker or an informant, but intentionally fails to absorb the information while still contextually being an audience, they are performing the act of fake or pseudo-listening.

These dynamics can lead to miscommunication or misinformation: both sides understand a subject differently, but one of them thinks they are on the same page. For the informant, this leads to a false sense of trust while the pseudo-listener thinks they will gain favors<sup>71</sup> or acknowledgment by not putting in an actual effort. This makes pseudo-listening an inauthentic behavior, and the tendency to engage in it can predict an individual's inauthenticity.

The behavior becomes more apparent in a political setting. Politicians and government officials often declare that they will listen to the people's opinions and aspirations. However, oftentimes we find demonstrations from people demanding rights or asking politicians to fulfill their promise. When opinions and aspirations are heard but not addressed seriously, it becomes ignorance. The act is disrespectful to the informant, especially when a person has the obligation and responsibility to listen. The more they listen falsely, the more they will think that it is okay to do so, and the easier it is to engage in inauthentic behavior.<sup>27</sup>

Entrepreneur Elon Musk (as cited in Bariso<sup>72</sup>) has a rule in his company, *Tesla*, which requires the employee to leave a meeting or drop a call if the person is not or feels like they are not contributing anything to the discussion. To Musk, it is ruder to stay and waste each other's time than leaving, because it is expected that not every meeting includes everyone that can provide a valuable contribution. Objectively, being a fake audience by fake-listening involves a personal agenda that is not really beneficial to anyone, especially in the long term. It can hinder effective organization processes and performances.<sup>73</sup> However, compared to being embarrassed or judged, fake listening is still thought to be a "better" option.

## Religious Hypocrisy

The fourth concern explores the relationship between religious hypocrisy and the inauthenticity of the self. Indonesia is a religious country. The first of the country's five main ideologies (Pancasila) is "Belief in One God".<sup>74</sup> Indonesia also has a Ministry of Religious Affairs that oversees all religion-related matters. However, there are at least two main examples of major government leaders affiliated with religious acts or organizations getting caught in corruption scandals. The first one is Ratu Atut Chosiyah, an ex-Governor of Banten. In 2014, Ratu was convicted of corruption for having bribed the then-Chief of Constitutional Court, Akil Mochtar with 3 billion Rupiah to win an election.<sup>75</sup> At that time, Ratu was known as an active campaigner of anti-corruption and religious values.<sup>76</sup> The second one is Suryadharma Ali, the ex-Minister of Religious Affairs, who was caught embezzling funds for the Muslim Hajj pilgrimage from 2010 to 2013.<sup>77</sup> These are the prime examples of how religious values are practiced as a formality or as tools for personal gain.<sup>78</sup> As corruption goes against religious values, acts committed by these leaders can be described as a form of religious hypocrisy.

Wollschleger and Beach<sup>79</sup> described it as a condition in which an individual tries to pursue benefit or reward from their own belief and minimize the cost by going against the objective rules of the belief. Hypocrisy is an act of deceit under the guise of public good,<sup>80</sup> and in this case, the public good is the religious value that many adopt. The higher the degree of hypocrisy, the more inauthentic they are. Thus, hypocrisy is defined by two main constructs:<sup>81</sup> public claim (declaring one's moral beliefs and value to others) and private action (private or hidden actions that deviate or go against the claim).

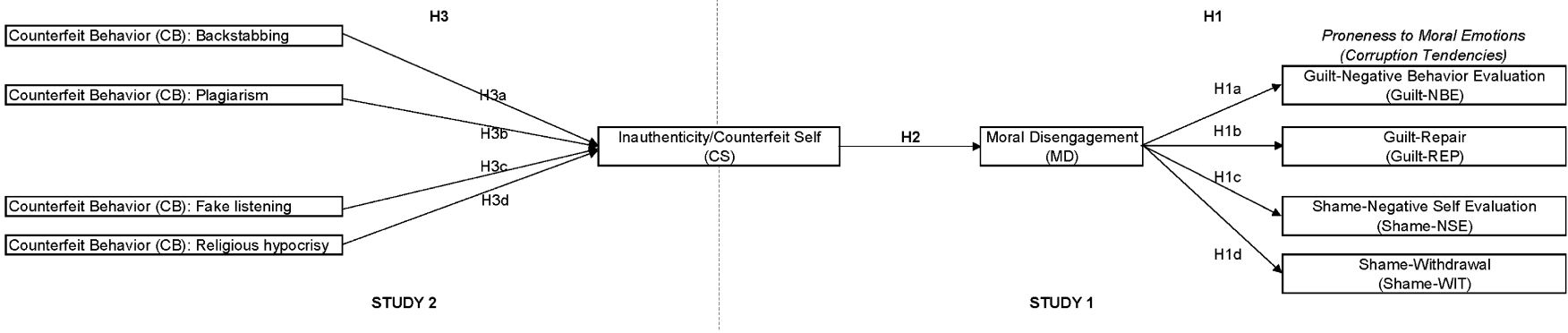

**Figure 1** Hypothetical model: Study 1 and Study 2.  
**Abbreviations:** CB, counterfeit behavior measured by its tendency; H, hypothesis.

One of the precipitating situations for religious hypocrisy is a “vertical” faith, in which a person believes in helping others because the religion said so, which is not truly accompanied by “horizontal” pro-social orientations.<sup>82</sup> The seemingly moral action is ultimately done for their own benefit (feeling morally superior, safe from judgment, perceived well by the others) and not others. The other reason is overpowered integrity, that one will objectify moral behavior until they cannot bear the cost, or their personal interest is stronger.<sup>82</sup> This is a form of being inauthentic. The moral sense of self and intention to act objectively is bound by subjective interest and context outside their religion.

## Materials and Methods

This study aims to test the major hypothesis, which is as follows:

Everyday counterfeit behavior can predict corruption tendencies (ie, guilt and shame proneness) through mediation of inauthenticity (ie, counterfeit self) and moral disengagement.

Based on the major hypothesis, three (3) minor hypotheses were derived, which are as follows:

1. H1: The higher the moral disengagement, the lower the proneness to guilt and shame (or in other words, the higher the corruption tendencies).

(a) H1a: The higher the moral disengagement, the lower the guilt-negative behavior evaluation (Guilt-NBE)

(b) H1b: The higher the moral disengagement, the lower the guilt-repair (Guilt-REP)

(c) H1c: The higher the moral disengagement, the lower the shame-negative self evaluation (Shame-NSE)

(d) H1d: The higher the moral disengagement, the lower the shame-withdrawal (Shame-WIT)

2. H2: The stronger the inauthenticity/counterfeit self, the higher the moral disengagement.

3. H3: The more intense the everyday counterfeit behavior (backstabbing, plagiarism, fake listening, religious hypocrisy), the higher the inauthenticity/ counterfeit self.

To aid visualization, the major and minor hypotheses are illustrated in [Figure 1](#).

## Design, Participants, and Data Analysis

This research applies a correlational-predictive design to test several propositions as depicted in [Figure 1](#). The data is gathered from Indonesians aged 18–40 years old (the age criterion is according to Erikson, as cited in Van den Broeck et al<sup>83</sup>). As many as 978 persons (380 males, 598 females;  $M_{age} = 23.64$  years old,  $SD_{age} = 4.35$  years) participated in this research, all of which were selected through a convenience sampling technique. The data was collected through an online questionnaire, facilitated by Google Form. The demographic information of the participants was as follow: In terms of domicile, 92% of participants lived in Greater Jakarta (termed as “Jabodetabek”; consisting of Jakarta-the capital city of Indonesia, and its surroundings: Bogor, Depok, Tangerang, and Bekasi), 6% lived in Java Island (outside Greater Jakarta), and 2% lived outside Java Island. In terms of employment, 50% of participants were University students, 32% were private employees, 4% were civil servants. The remainder (14%) were persons with various occupations, eg, entrepreneurs, freelancers, housewives, lecturers, teachers, and researchers. In terms of formal education, 43% of participants were Senior High School graduates, 19% were Bachelor’s, 10% were held Diplomas, 6% were Master’s, and 0.5% were Doctoral graduates, while 21.5% were unwilling to fill in the formal education part of the questionnaire. In terms of ethnicity, 16% were Javanese, 8% were Sundanese, 5% were Betawi, 4% were Chinese, 3% were Padang, 2% were Malay, 2% were Batak. The remaining (60%) came from various ethnic groups in Indonesia; Aceh, Ambon, Bali, Arab, Makassar, Medan, Bengkulu, Nias, Flores, Minang, Manado, etc.

The research was carried out in accordance with the Declaration of Helsinki’s criteria. This research was funded and ethically and substantively reviewed by Directorate of Resources, Directorate General of Higher Education, The Indonesian Ministry of Education, Culture, Research, and Technology, in accordance with the Research Contract for Fiscal Year 2021, Number: 163/E4.1/AK.04.PT/2021, 3481/LL3/KR/2021, July 12, 2021, with the research entitled, “Exploring the Contribution of Personality and Societal Cultural Orientation in Explaining Attitudes Toward Disruptive

Changes". This study was also approved by Ethics Committee of Research and Technology Transfer Office, Bina Nusantara University with Letter No. 042/VR.RTT/VI/2021, article 1.

All participants were required to complete a written informed consent form and fill in an Indonesian language questionnaire containing: (a) a Guilt and Shame Proneness/Corruption Tendency scale (the dependent/criterion variable) (N = 978), (b) moral disengagement scale (mediating variable - 1) (N = 978), and (c) counterfeit self scale (mediating variable - 2) (N = 978). However, in the measurement of the counterfeit behavior scale (the independent/predictor variable), the participants were given choices to fill in just one of the following scales based on their preference: (a) backstabbing scale (N = 249), (b) plagiarism tendency scale (N = 193), (c) fake listening scale (N = 273), or (d) religious hypocrisy scale (N = 263). The participants' freedom to choose applies a between-subject design so that the participants can select the type of counterfeit behavior they often encounter in their daily lives and to prevent fatigue from having to complete too many psychological scales.

The data analysis of this study applies the JASP version 0.11.1.0 for Windows software. From the initial stages, the authors were aware of the limitations and statistical capacity of this software in simultaneously analyzing the hypotheses (H1, H2, and H3), and as such, the research comprised of the two following studies:

*Study 1* analyzed the predictive relationship between inauthenticity/counterfeit self, moral disengagement, and corruption tendency (guilt and shame proneness/GASP) to test the H1 (H1a, H1b, H1c, H1d) and H2 hypotheses. Study 1 aims to confirm the existence of the following psychological processes (Figure 1):

- (a) Inauthenticity/counterfeit self → Moral disengagement → Guilt-NBE.
- (b) Inauthenticity/counterfeit self → Moral disengagement → Guilt-REP.
- (c) Inauthenticity/counterfeit self → Moral disengagement → Shame-NSE.
- (d) Inauthenticity/counterfeit self → Moral disengagement → Shame-WIT.

*Study 2* analyzed the predictive relationship between counterfeit behavior and inauthenticity/counterfeit self. Study 2 aims to confirm the existence of the following psychological processes (Figure 1):

- (a) Backstabbing → Inauthenticity/counterfeit self (H3a)
- (b) Plagiarism tendency → Inauthenticity/counterfeit self (H3b)
- (c) Fake listening → Inauthenticity/counterfeit self (H3c)
- (d) Religious hypocrisy → Inauthenticity/counterfeit self (H3d)

The data and results of data processing (JASP output, including information on factor loadings of CFA, and estimates of mediation analysis) of this research can be accessed through the following link: <https://doi.org/10.5281/zenodo.5713365>. The data analysis applied in this study is as follows:

*Study 1* applied mediation analysis with inauthenticity/counterfeit self as the predictor, moral disengagement as the mediator, and Guilt-NBE, Guilt-REP, Shame-NSE, and Shame-WIT as the criterion variables.

*Study 2* is analyzed with simple linear regression, which was conducted four times. The predictors consisted of the four types of counterfeit behavior, ie, (a) backstabbing, (b) plagiarism, (c) fake listening, and (d) religious hypocrisy while the criterion is inauthenticity/ counterfeit self.

Reliability analyses of each measurement used standardized Cronbach's Alpha ( $\alpha$ ), whereas instrument validity used construct validity (Confirmatory Factor Analysis/CFA).

## Instruments

### Study 1: Corruption Tendency, Moral Disengagement, and Inauthenticity/Counterfeit Self

The *Guilt and Shame Proneness (GASP/Corruption tendency) scale* was adapted from Cohen et al.<sup>26</sup> This scale consisted of four dimensions, ie, guilt-negative behavior evaluation (Guilt-NBE), guilt-repair (Guilt-REP), shame-negative self evaluation (Shame-NSE), and shame-withdrawal (Shame-WIT). In this present study, all four dimensions were treated as four dependent variables. In line with the constructor's results of the Confirmatory Factor Analyses (Cohen et al 2011), the four-factor model best fits the data compared to the one-, two-, and three-factor model.

The sample items<sup>26</sup> (p. 966) included:

**Table 1** Reliability and Validity Indices of Study 1's Instrument

Variable	Total Items (Before; After Validation)	Standardized Cronbach's Alpha ( $\alpha$ )/ Internal Consistency Reliability	Confirmatory Factor Analysis (CFA) Model Indices/Construct Validity
Guilt-Negative Behavior Evaluation (Guilt-NBE)	4; 4	0.716 (N = 978)	$\chi^2 = 4.924$ ; $df = 2$ ; $p = 0.085$ SRMR = 0.013 GFI = 0.997 CFI = 0.996
Guilt-Repair (Guilt-REP)	4; 4	0.637 (N = 978)	$\chi^2 = 3.793$ ; $df = 2$ ; $p = 0.150$ SRMR = 0.015 GFI = 0.998 CFI = 0.996
Shame-Negative Self Evaluation (Shame-NSE)	4; 4	0.697 (N = 978)	$\chi^2 = 14.371$ ; $df = 2$ ; $p = 0.000$ SRMR = 0.026 GFI = 0.993 CFI = 0.982
Shame-Withdrawal (Shame-WIT)	4; 0 (All items dropped)	0.560 (N = 978)	$\chi^2 = 8.616$ ; $df = 2$ ; $p = 0.013$ SRMR = 0.023 GFI = 0.996 CFI = 0.979
Moral Disengagement	8; 8	0.737 (N = 978)	$\chi^2 = 170.337$ ; $df = 32$ ; $p = 0.000$ SRMR = 0.053 GFI = 0.965 CFI = 0.923
Inauthenticity/Counterfeit Self	12; 10 (2 items dropped*)	0.628 (N = 978)	$\chi^2 = 159.162$ ; $df = 20$ ; $p = 0.000$ SRMR = 0.049 GFI = 0.961 CFI = 0.884

Notes: N = sample size (cf. <https://doi.org/10.5281/zenodo.5713365>).

After realizing you have received too much change at a store, you decide to keep it because the sales clerk doesn't notice. What is the likelihood that you would feel uncomfortable about keeping the money? (Guilt-NBE),

You are privately informed that you are the only one in your group that did not make the honor society because you skipped too many days of school. What is the likelihood that this would lead you to become more responsible about attending school? (Guilt-REP),

You rip an article out of a journal in the library and take it with you. Your teacher discovers what you did and tells the librarian and your entire class. What is the likelihood that this would make you would feel like a bad person? (Shame-NSE),

After making a big mistake on an important project at work in which people were depending on you, your boss criticizes you in front of your coworkers. What is the likelihood that you would feign sickness and leave work? (Shame-WIT).

Participants were asked to rate how much these items apply to them using a 7-point Likert scale, from 1 (*Very Unlikely*) to 7 (*Very Likely*). The higher the score of each scale show greater proneness to moral emotions.

The *Moral disengagement (MD)* scale was adapted from the *Propensity to Morally Disengage scale* by Moore et al.<sup>37</sup> The scale has 3 different versions containing 24-items (3 items in each dimension), 16-items (2 items in each dimension), and 8-items (1 item in each dimension). Through various convergent and discriminant validity testing conducted by Moore et al.<sup>37</sup> the 8-item version is deemed reliable for use. This study used 8 items in which each item represents each dimension of Moral Disengagement, with responses also rated on 6-point Likert scale describing participants' agreement

towards each statement ranging from 1 (*Strongly Disagree*) to 6 (*Strongly Agree*). The sample items included: “It doesn’t matter if I take something without permission as long as I return it” (Euphemistic Labeling), and “A person cannot be prosecuted for his wrongdoings if all of their other friends are doing it” (Distortion of Consequences). The higher the score in this scale indicates greater moral disengagement of a person.

The *Inauthenticity/Counterfeit self* is measured by the Authenticity Scale by Wood et al.<sup>40</sup> The scale consists of three dimensions; (1) Authentic Living, (2) Self-alienation, and (3) Accepting External Influence. Each scale consists of 4 items (total 12 items) describing the participants’ authentic evaluations of the self. Participants were asked to rate how much these items best describe them using a 6-point Likert scale, ranging from 1 (*Strongly Disagree*) to 6 (*Strongly Agree*). Sample items include “I feel that it is more important to be popular than to be myself (Authentic Living)”, “I don’t know how I feel inside (Self-alienation)”, and “I always do what others tell me to do” (Accepting External Influence). The higher the score in this scale shows the greater a person’s degree of inauthenticity.

Table 1 displays the results of the validity and reliability test for all dependent variables (Guilt-NBE, Guilt-REP, Shame-NSE, and Shame-WIT) and mediating variables (moral disengagement and inauthenticity/counterfeit self) contained in Figure 1. The CFA models of all variables in this research fulfilled at least 2 of 3 of the following criteria:  $CFI > 0.80$ ;  $SRMR < 0.08$ ;  $GFI > 0.90$  based on Akkus<sup>84</sup> (p. 712–713).

However, the Shame-WIT scale did not meet the reliability standard ( $\alpha < 0.600$ ) and therefore was excluded from further analyses. The lack of reliability of the Shame-WIT scale was found in numerous studies, such as those conducted by Abraham and Pea<sup>25</sup> as well as Abraham and Berline<sup>85</sup> indicating how the scale requires revision.

## Study 2: Counterfeit Behavior

*Backstabbing* was measured using the *Backstabbing Behavioral Scale* developed by the authors. Due to the lack of literature on the subject of backstabbing, the author constructed dimensions of backstabbing based on observations of backstabbing’s commonalities.<sup>62</sup> They are (1) false friendship, defined as a good relationship with backstabbing target as means to put them down; (2) defamation, defined as tendencies to put the target down; (3) impression management, defined as the tendency to elevate one’s own image in comparison to others; and (4) private gain, tendencies to look for personal benefits in the process of backstabbing. Each dimension consists of five items (total of 20 items). Participants were asked to rate each statement based on how much they think the statement describes their selves using a 5-point Likert scale ranging from 1 (*Very Unlike Me*) to 5 (*Very Like Me*). Samples of items include: “Andi once slandered his friend’s reputation because he wanted to look better in front of other people”, “When talking about other people’s badness, Andi always thinks about how the situation will benefit him”.

*Plagiarism* tendency was measured using the *Revised Plagiarism Attitude Scale*.<sup>86</sup> The scale was divided into three dimensions (22 items): (1) Justification for plagiarism (6 items); (2) Severity and penalty (7 items); and (3) Factors that exacerbate plagiarism (8 items). Participants were asked to rate their degree of agreement towards statements presented in each item using a 6-point Likert scale from 1 (*Strongly Disagree*) to 6 (*Strongly Agree*). Samples of the items were: “Those who say they have never plagiarized are lying.” (Justification for plagiarism), “Plagiarism is not a big deal.” (Severity and penalty), and “I am tempted to plagiarize if I currently have more important obligations or tasks to do.” (Factors that exacerbate plagiarism).

*Fake listening* was measured using an instrument constructed by the authors. The first part of the instrument measures behavioral and cognitive aspects, divided into two dimensions: (a) body language (5 items), and (b) social cognition (10 items). The body language dimension draws concepts from Stinson<sup>87</sup> as well as Listen and Lead.<sup>88</sup> While the social cognition dimension is adapted from the 10 pseudo-listening characteristics by Hargie.<sup>71</sup> Samples of the items include “I often nod my head in response to the speaker, even though I don’t really understand what is being said” (body language) and “I pretended to listen to get the speaker to like me when I wasn’t really listening to what he was saying” (social cognition). The second part of the instrument measures the emphatic and intent aspects of fake listening as adapted from Drollinger et al.<sup>89</sup> on three stages of the communication process with each stage treated as a dimension, comprising (a) sensing (4 items), (b) processing (3 items), and (c) responding (4 items) Sample items included “I can’t feel what the other person isn’t saying, even though I behave as if I have empathy for what he or she is saying” for sensing, “I reassure others that I will remember what they say, despite the fact that I do not remember what they say at all” for processing,

**Table 2** Reliability and Validity Indices of Study 2's Instrument

Variable	Total Items (Before; After Validation)	Standardized Cronbach's Alpha ( $\alpha$ )/ Internal Consistency Reliability	Confirmatory Factor Analysis (CFA) Model Indices/Construct Validity
Backstabbing	20; 11 (9 items dropped)	0.805 (N = 249)	$\chi^2 = 107.544$ ; $df = 29$ ; $p = 0.000$ SRMR = 0.079 GFI = 0.924 CFI = 0.898
Plagiarism tendency	22; 15 (7 items dropped)	0.880 (N = 193)	$\chi^2 = 226.416$ ; $df = 101$ ; $p = 0.000$ SRMR = 0.063 GFI = 0.876 CFI = 0.866
Fake listening	26; 25 (1 item dropped)	0.946 (N = 273)	$\chi^2 = 799.973$ ; $df = 265$ ; $p = 0.000$ SRMR = 0.060 GFI = 0.811 CFI = 0.877
Religious hypocrisy	25; 13 (12 items dropped)	0.645 (N = 263)	$\chi^2 = 69.311$ ; $df = 34$ ; $p = 0.000$ SRMR = 0.051 GFI = 0.956 CFI = 0.892

Notes: N = Sample size (cf. <https://doi.org/10.5281/zenodo.5713365>).

and “I reassure others that I’m listening by giving verbal responses, even though I’m not really listening at all” for responding. Participants were asked to rate their degree of agreement towards statements presented in each item using a 6-point Likert scale from 1 (*Strongly Disagree*) to 6 (*Strongly Agree*).

*Religious hypocrisy* was also measured using an instrument constructed by the authors from the dimensions of religious life and hypocrisy. There are five types of religious hypocrisy based on the five dimensions of religious life:<sup>90</sup> intellectual hypocrisy, ideological hypocrisy, public practice hypocrisy, private practice hypocrisy, and religious experience hypocrisy. Intellectual hypocrisy is shown by the discrepancies between claimed religious knowledge and the actual practice or the possibility of this knowledge to be applied as it is. Ideological hypocrisy is the discrepancies between claimed belief and faith in public while declaring otherwise or disregarding the faith privately. Public practice hypocrisy is shown by the discrepancies of participation and actual belongingness, in which a person is present in religious gatherings or activities, but does not actually feel that they belong there, or because of other reasons unrelated to the religion. Private practice hypocrisy is the discrepancies between engaging in private religious rituals, and actually devoting, concentrating, and finding purpose in the action. Finally, the religious experience hypocrisy is shown by the discrepancies between religious experience and the actuality of the event or feelings that emerge. Simply put, it is the degree to which an individual fabricates a religious experience (enlightenment, humility, transcendence) for personal purposes.

The religious hypocrisy instrument consists of five dimensions, with five items each measuring the hypocrisy of religious life: intellectual hypocrisy, ideological hypocrisy, public practice hypocrisy, private practice hypocrisy, and religious experience hypocrisy. Sample items include “It looks as if you think a lot about religion, even though that’s not the case” for intellectual hypocrisy, “Not showing doubts about God even though there are still a few doubts” for ideological hypocrisy, “Prioritizing public worship activities above other activities, although with a heavy heart” for public practice hypocrisy, “Tell others about your personal worship practices that didn’t actually happen” for private practice hypocrisy, and “Share your religious experiences with those around you, even if you’re not sure you’ll get the meaning of those experiences yourself.” for religious experience hypocrisy. Participants were asked to rate the frequency

**Table 3** Descriptive Statistics

	<b>Guilt-NBE</b>	<b>Guilt-REP</b>	<b>Shame-NSE</b>	<b>Moral Disengagement</b>	<b>Inauthenticity</b>	<b>Backstabbing</b>	<b>Plagiarism</b>	<b>Fake Listening</b>	<b>Religious Hypocrisy</b>
<b>N</b>	978	978	978	978	978	249	193	273	263
<b>Mean</b>	5.214	5.305	5.467	2.578	3.268	2.649	3.140	3.163	2.258
<b>Std. Error of Mean</b>	0.038	0.033	0.037	0.026	0.021	0.040	0.062	0.053	0.027
<b>Std. Deviation</b>	1.192	1.030	1.148	0.805	0.643	0.637	0.865	0.872	0.431
<b>Minimum</b>	1.500	1.500	1.000	1.000	1.300	1.000	1.070	1.192	1.230
<b>Maximum</b>	7.000	7.000	7.000	5.750	5.600	4.640	5.200	5.346	4.150

**Abbreviations:** Guilt-NBE, guilt-negative behavior evaluation; Guilt-REP, guilt-repair; Shame-NSE, shame-negative self evaluation.



**Table 4** Pearson Correlation Between Inauthenticity/Counterfeit Self, Moral Disengagement, and Proneness to Various Moral Emotions (N = 978)

		Inauthenticity/ Counterfeit Self	Moral Disengagement	Guilt-NBE	Guilt-REP	Shame- NSE
<b>Inauthenticity/ Counterfeit Self</b>	<i>r</i>	—				
	<i>p</i>	—				
	Upper 95% CI	—				
	Lower 95% CI	—				
<b>Moral Disengagement</b>	<i>r</i>	0.154***	—			
	<i>p</i>	$1.356 \times 10^{-6}$	—			
	Upper 95% CI	0.214	—			
	Lower 95% CI	0.092	—			
<b>Guilt-NBE</b>	<i>r</i>	0.013	-0.153***	—		
	<i>p</i>	0.692	$1.481 \times 10^{-6}$	—		
	Upper 95% CI	0.075	-0.091	—		
	Lower 95% CI	-0.05	-0.214	—		
<b>Guilt-REP</b>	<i>r</i>	0.042	-0.178***	0.622***	—	
	<i>p</i>	0.185	$1.941 \times 10^{-8}$	$1.180 \times 10^{-105}$	—	
	Upper 95% CI	0.105	-0.117	0.659	—	
	Lower 95% CI	-0.02	-0.238	0.582	—	
<b>Shame-NSE</b>	<i>r</i>	0.116***	-0.148***	0.676***	0.655***	—
	<i>p</i>	$2.770 \times 10^{-4}$	$3.417 \times 10^{-6}$	$8.158 \times 10^{-132}$	$4.429 \times 10^{-121}$	—
	Upper 95% CI	0.177	-0.086	0.709	0.69	—
	Lower 95% CI	0.054	-0.209	0.641	0.618	—

Note: \*\*\* $p < 0.001$ .

Abbreviations: Guilt-NBE, guilt-negative behavior evaluation; Guilt-REP, guilt-repair; Shame-NSE, shame-negative self evaluation.

of doing these actions by choosing between “Never” (scored 1), “Seldom” (scored 2), “Sometimes” (scored 3), “Often” (scored 4), and “Very Often” (scored 5).

Table 2 displays the results of the validity and reliability test of all independent variables (backstabbing, plagiarism tendency, fake listening, and religious hypocrisy) contained in Figure 1. The CFA models of all variables in this researched fulfilled at least 2 of 3 of the following criteria:  $CFI > 0.80$ ;  $SRMR < 0.08$ ;  $GFI > 0.90$  based on Akkış<sup>84</sup> (p. 712–713).

## Results

### Descriptive Statistics

Table 3 shows the descriptive statistics of each variable measured in this study.

#### Study I: Predictive Correlation Between Inauthenticity/Counterfeit Self, Moral Disengagement, and Proneness to Moral Emotions (Guilt and Shame)

The correlation analysis between inauthenticity/counterfeit self, moral disengagement, and proneness to moral emotions (guilt and shame/GASP) or corruption tendencies are provided in Table 4. The table shows that inauthenticity/counterfeit self and the majority of moral emotion proneness are not directly related. Moral disengagement was found to have a direct correlation with all moral emotion proneness as well as with inauthenticity/counterfeit Self. Thus, moral disengagement can be considered as a good mediator in the relationship between inauthenticity/counterfeit self and various proneness to moral emotions (Guilt-NBE, Guilt-REP, Shame-NSE).

The results of predictive analysis (see Table 5 and Figure 2) show that inauthenticity/counterfeit self can indirectly predict proneness to various moral emotions (Guilt-NBE, Guilt-REP, Shame-NSE) through the mediation of moral disengagement (all  $p < 0.01$ ). Therefore, hypotheses H1 (H1a, H1b, H1c, H1d) and H2 are supported by empirical data.

**Table 5** Mediation Analysis Showing Indirect Prediction of Inauthenticity/Counterfeit Self Towards Proneness to Various Moral Emotions Through Moral Disengagement (N = 978)

Mediation Model	Estimate	Std. Error	z	p	95% Confidence Interval	
					Lower	Upper
Inauthenticity/ Counterfeit Self → Moral Disengagement → Guilt-NBE	-0.038	0.011	-3.478	$5.047 \times 10^{-4}$	-0.059	-0.017
Inauthenticity/ Counterfeit Self → Moral Disengagement → Guilt-REP	-0.045	0.012	-3.770	$1.629 \times 10^{-4}$	-0.069	-0.022
Inauthenticity/ Counterfeit Self → Moral Disengagement → Shame-NSE	-0.041	0.011	-3.602	$3.155 \times 10^{-4}$	-0.063	-0.018

**Notes:** Delta method standard errors, normal theory confidence intervals.

**Abbreviations:** Guilt-NBE, guilt-negative behavior evaluation; Guilt-REP, guilt-repair; Shame-NSE, shame-negative self evaluation.

**Study 2: Predictive Correlation Between Counterfeit Behavior and Inauthenticity/Counterfeit Self**

The simple linear regressions (see Table 6) show that:

1. Backstabbing can predict inauthenticity/counterfeit self,  $F(1, 248) = 14.457, p = 0.000, R^2 = 0.055$ , in a positive way ( $\beta = 0.235, p = 0.000$ ). Hypothesis H3a is supported by empirical data.

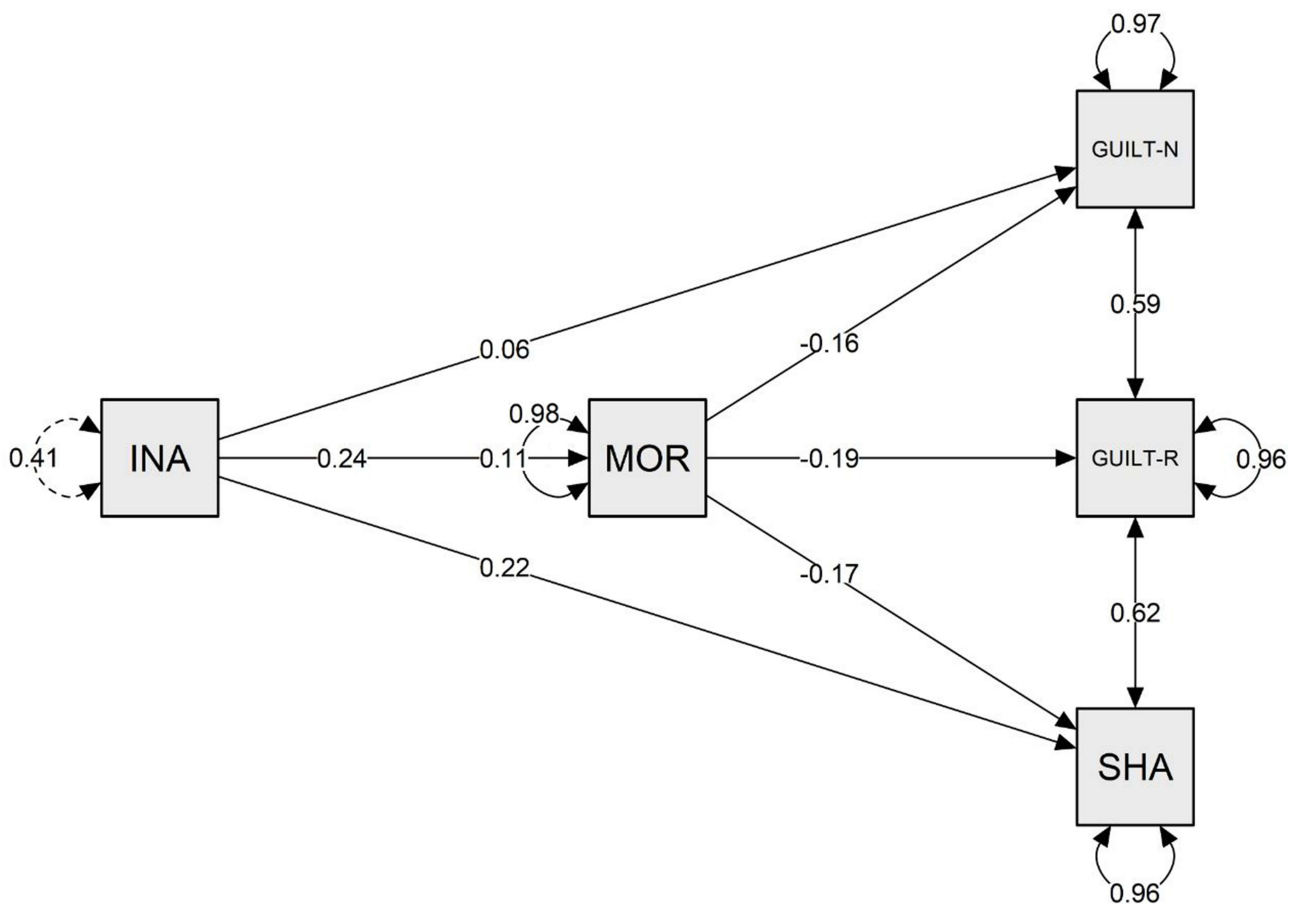

**Figure 2** Visualization of mediation analysis results predicting moral emotions (N = 978).

**Notes:** Shame-Withdrawal is eliminated from this model because the Shame-WIT scale is unreliable (Cronbach's  $\alpha < 0.600$ ). This is the data analysis output from the free and open-source JASP software.

**Abbreviations:** INA, inauthenticity/counterfeit self; MOR, moral disengagement (MD); Guilt-N, guilt-negative behavior evaluation (Guilt-NBE); Guilt-R, guilt-repair (Guilt-REP); SHA, shame-negative self evaluation (Shame-NSE)

**Table 6** Simple Linear Regressions Predicting Inauthenticity/Counterfeit Self

Predictor	Unstandardized	Standard Error	$\beta$	t	p	95% Confidence Interval		Collinearity Statistics	
						Lower	Upper	Tolerance	VIF
Backstabbing	0.228	0.060	0.235	3.802	$1.808 \times 10^{-4}$	0.110	0.346	1.000	1.000
Plagiarism	0.106	0.042	0.182	2.551	0.012	0.024	0.189	1.000	1.000
Fake Listening	0.125	0.036	0.206	3.462	$6.224 \times 10^{-4}$	0.054	0.196	1.000	1.000
Religious Hypocrisy	0.147	0.070	0.128	2.092	0.037	0.009	0.284	1.000	1.000

2. Plagiarism tendency can predict inauthenticity/counterfeit self,  $F(1, 192) = 6.508, p = 0.012, R^2 = 0.033$ , in a positive way ( $\beta = 0.182, p = 0.012$ ). Hypothesis H3b is supported by empirical data.
3. Fake listening can predict inauthenticity/counterfeit self in a positive way,  $F(1, 272) = 11.987, p = 0.000, R^2 = 0.042$ , in a positive way ( $\beta = 0.206, p = 0.000$ ). Hypothesis H3c is supported by empirical data.
4. Religious hypocrisy can predict inauthenticity/counterfeit self in a positive way,  $F(1, 262) = 4.378, p = 0.037, R^2 = 0.016$ , in a positive way ( $\beta = 0.128, p = 0.037$ ). Hypothesis H3d is supported by empirical data.

Therefore, hypothesis H3 is supported by empirical data.

## Discussion

This present study investigates the process of developing a tendency for corruption in the era of digital disruption, which assumes that in this age, one's morality is at greater risk due to the development of various counterfeit behaviors. The results of this study show that the major hypothesis which suggests

Everyday counterfeit behavior can predict corruption tendencies (i.e., guilt and shame proneness) through mediation of inauthenticity (counterfeit self) and moral disengagement

- along with the three minor hypotheses (H1, H2, H3) - are supported by empirical data. Both studies altogether showed that inauthenticity/counterfeit self has the capacity to predict proneness to moral emotion (guilt and shame/GASP) through moral disengagement (Study 1); meanwhile, inauthenticity/counterfeit self can be predicted by four kinds of counterfeit behavior, namely backstabbing, plagiarism tendency, fake listening, and religious hypocrisy (Study 2).

The range of psychological processes are: The stronger the everyday counterfeit behavior, the higher the inauthenticity/counterfeit self. The higher the inauthenticity/counterfeit self, the higher the moral disengagement. The higher the moral disengagement, the lower the proneness to guilt and shame (or in other words, the higher the corruption tendencies).

These results confirm Hofmann et al's<sup>91</sup> statement, (p. 1340), "In sum, morality science may benefit from a closer look at the antecedents, dynamics, and consequences of everyday moral experience." This study investigates counterfeit behavior, which is everyday behavior that is generally thought to be a common byproduct or excess of the 4.0 Industry zeitgeist; for example, Stacey<sup>92</sup> discussed plagiarism, and Wanschers<sup>93</sup> discussed backstabbing. Notwithstanding this, both discussions have not reached the extent of empirical investigation regarding the psychological dynamics of human morality. Therefore, the results of this study fill the gaps in those facets.

In terms of (1) the nature of this present study which is cross-sectional, one-shot, using a self-report questionnaire, and (2) the social nature of moral emotions (guilt and shame) which is positioned in this study as the "estuary" of counterfeit behavior in the context of cultural disruption due to the present 4.0 Industry, this research is compatible with the nature of empirical reality where moral valuations "are usually fast, almost automatic, yet they are culturally shaped and socially embedded"<sup>94</sup> (p. 387). This is represented by the fact of this present study's procedure that, temporally, the participants' process in completing the research questionnaire can be considered a simulation of how people choose their moral behavior within a short period. Moral emotions in this study are "psychological products" that are created after a person becomes aware of the receptiveness or, in contrast, rejection towards counterfeit behavior through the mediation of counterfeit self and moral disengagement.

This research emphasizes a statement by White<sup>95</sup> (p. 219, 236–237) suggested almost three decades ago who mentioned:

That the social and the conceptual need to be incorporated as primary determinants of emotion rather than as secondary or surface phenomena .... that emotions are everywhere prototypically social ... that are probably always in flux and subject to the moment-by-moment negotiations of social interaction.

As seen from this study, the four kinds of counterfeit behavior, ie, backstabbing, plagiarism, fake listening, and religious hypocrisy, have a chain effect on an individual's susceptibility to experience moral emotions when committing moral violations. The nature of this effect is erosive towards healthy moral emotions, which then increase one's

corruption tendencies. In essence, the four counterfeit behaviors are human efforts to display self-image in the face of the social environment with deliberate disregard of authentic personal circumstances.<sup>17</sup>

However, the results of this study differ from findings by Hofmann et al<sup>91</sup> regarding moral licensing, which mentions that (p. 1343):

a moral self-licensing pattern emerged, such that committing a moral act earlier in the day was associated with an above-average likelihood of a subsequent immoral act and a decreased likelihood of a subsequent moral act.

On the contrary, the results of this research revealed the occurrence of “moral consistency” rather than “moral licensing”. After a person realizes that they support counterfeit behavior, what happens in the psychological process that follows is immoral personality (counterfeit self), immoral thought (moral disengagement), and immoral feeling (lower guilt and shame proneness); or more simply put as an immoral act tendency in the form of corruption tendency. The two theoretical paradigms in the human’s moral psyche: moral consistency (immoral tendency following immoral past condition) vs moral licensing (moral tendency following immoral past condition) appears to be an endless debate in moral psychology. Mullen and Monin<sup>96</sup> summarized this argument in an article published in the *Annual Review of Psychology* in which they suggested several moderators that can alter the direction of morality through moral consistency or moral licensing patterns. According to Ellemers et al<sup>97</sup> both moral consistency and moral licensing functions to protect moral self-image or a person’s moral self-view. If applied in the results of this study, the most applicable moderator to produce moral consistency is value reflection (private vs public initial act). As explained by Mullen and Monin<sup>96</sup> (p. 377):

A private choice led individuals to reflect on their values, to embrace the identity indicated by the initial behavior, and to display [moral] consistency, whereas a public behavior seemingly did not trigger the same value reflection.

The common conception of one’s counterfeit behavior - as it is a person’s effort to conceal the motive for their behavior - is that it is a result of a private choice. A person “chooses” to present behavior that does not align with their true self. For example, a person may present an actively listening behavior where they are in fact not listening. As stated in the *Introduction*, fake behavior and culture have become a narrative identity. This identity appears to be advocated by people who possess it, and it is therefore unsurprising that counterfeit behavior produces counterfeit self to the extent that people are willing to experience a weakening of moral emotional proneness.

Abraham et al<sup>17</sup> found that the counterfeit self - A form of mental corruption of the self that results in the feeling of separation from the true self - is a strong predictor of corrupt behavior and moral disengagement, although this finding was not derived from a study as elaborate as the present study. Gino et al<sup>27</sup> found that counterfeit behavior - the behaviors of faking one’s intent and image for positive gain, leads to inauthenticity and more frequent cheating, but the scope of their study was limited to economic behavior. However, by combining these two studies, we arrive at the understanding that wearing counterfeit products or presenting oneself in a false image is a lesser form of unethical behavior, much like backstabbing, plagiarism, religious hypocrisy, and fake listening are, compared to deliberate cheating and dishonest behaviors like corruption. The consequences might not be as dire as corruption, but these behaviors are very well in the grey area of morality but individuals might continue to perform them due to moral disengagement mechanisms. The four counterfeit behaviors are not uncommon and are not beneficial to the community, institution, or organization to which it occurs. Detecting them early can provide insights on how authentic a person is, how they evaluate themselves and their behavior, and how likely they are to use moral disengagement mechanisms.

This present study also affirms the role of the moral disengagement in detaching individuals from their moral emotions. Gino et al<sup>45</sup> found that inauthenticity or recalling the experience of behaving inauthentically can lead a person to feel impure and incite the desire to behave pro-socially. The process of recalling makes us in touch with our moral emotions, and to repair guilt or make us feel less shameful, we take actions that make our moral self feel better as an act of retribution. However, this is the case in a general day-to-day context. We argued that it might be different in a specific environment where there are rules to be adhered to and goals to be achieved. In an organizational context where there are performance and relationship expectations, every organizational member has personal interests, such as increasing their salary, getting a day-off or promotion, or project approval. To do this, they need to build relationships

with other members, supervisors, partners, and other stakeholders and show their capability. One of the ways these interests can be pursued quicker is through shortcuts that often indicate a detachment from moral awareness.<sup>17</sup> For example, one might pretend to be interested in their co-worker or boss' stories but is not actually listening, badmouthing their colleagues in front of their boss or other employees, or take their colleague's ideas and claim it as their own. In the process, moral disengagement mechanisms (1) block an individual's ability to feel impure, and (2) block his/her drive to behave pro-socially. Gino et al<sup>27</sup> also found that individuals might not be aware of the consequences of their unethical behavior. This supports the results of this present study whereby individuals are found to be detached from moral emotions, and, although their behaviors are unethical, their need to achieve goals faster are facilitated by this mechanism, making them less able to feel moral emotions and to do something about them.

The explanation below presents an illustration of *the mental scenario*, which elaborates all the dynamics of moral consistency that is derived from four kinds of counterfeit behavior, ie, backstabbing, plagiarism, fake listening, and religious hypocrisy.

The act of *backstabbing* was able to predict a person's inauthenticity and tendency to disengage morally. Backstabbing is a destructive consequence of inauthentic emotional management in the form of emotional game-playing.<sup>98</sup> One might try to act supportive and affirmative to gain the favor of a colleague or a supervisor, but then talk about them behind their back or undermine them when their help is no longer needed. An individual is less likely to feel remorse for their inauthentic behavior. In the case of backstabbing, moral justification and advantageous comparison mechanisms are likely used to justify the action.

*Fake listening*, on the surface, in the short term, and with taking certain precautions, maybe less harmful towards the fake listeners and their communication partner. A fake listener that engages in the moral disengagement mechanism may even find it rewarding to fake listen, as it helps them avoid responsibilities while maintaining a good image. After all, in most cases, not listening carefully or not listening at all does not directly harm others mentally or physically as it will be only time-wasting at a glance. But to a fake listener, this is only a small inconvenience that can be ignored in the process of pursuing the reward. Milder negative implications might only come if the person does not hide it well on multiple occasions, threatening their credibility as a professional or a social member. We might be able to see bigger negative consequences when fake listening is done repeatedly in an institutional setting, with the fake listener being responsible for managing resources. However, *fake listening* can predict one's inauthenticity and moral disengagement. Individuals who pretend to listen to maintain a positive image and please others are more likely to morally disengage and feel less guilty about their actions. As a person adopts the habit of fake listening, the more inauthentic they become due to the inability to contribute as a participant in a social or professional convention. This is not due to the lack of capability, but rather disengagement from the responsibilities of their capability and duty as a partner in communication and enforcer of the discussed information. This makes them inauthentic people and thus explains their tendency to be morally disengaged. Advantageous comparison and distortion of consequences are likely to be the foundation of the behavior. Whereas pseudo-listening, as the opposite of empathic listening, does not send the true message of trust, acknowledgment, and appreciation.<sup>99</sup> Drawing examples from classroom settings, a study conducted by Baron<sup>100</sup> showed that pseudo-listening or pseudo-presence might be done to please authority figures, such as parents, and is a sign of the lack of authenticity in the system in which it occurs. The study suggests that another mechanism, being the diffusion of responsibilities, might be used here as pseudo-listening occurs in collective settings. Seeing others doing it as a common practice might make the pseudo-listener feel fine in doing it as well, hence the lack of shame and guilt.

As a person tolerates *plagiarism* and views it more positively, their tolerance towards authentic creation and self-presentation also decreases. There is less need to be truly authentic when others' works can make one appear good and presentable, thus the self is encouraged to become more and more inauthentic. There is also a need to keep up with the self-image that is created using other people's work. To keep this fake authentic presentation, individuals will have to tolerate and perhaps engage in more morally disengaged behavior, such as lying, faking, and more plagiarizing. To gain benefits from plagiarizing and avoid the consequences, plagiarizers tend to moralize their behavioral tendencies via distortion of consequences by rationalizing that the victim is not harmed, or calling the plagiarism behavior with other less harmful terms. Plagiarism is often done in a desperate attempt to meet expectations. De Vries<sup>99</sup> explained that in

a stressful or threatening situation, individuals will regress into a pattern of dependency on people who they perceive as stronger, thus leading them to behave inauthentically. This explains the predictive ability of inauthenticity/counterfeit self towards propensity to moral disengagement, and then moral disengagement towards lower moral emotions proneness.

*Religious hypocrisy* also predicts inauthenticity. The more an individual is hypocritically religious, the less they will feel bad about their inauthentic actions and themselves. Moral justification and euphemistic labeling mechanisms are likely used to justify their inauthentic actions. They are also less likely to feel the need to resolve their guilt and shame.

To resolve lots of social problems raised from the basis of corruption tendency, ie, counterfeit behavior, this study suggests efforts to increase moral awareness. Awareness is the antidote for counterfeit behavior. Moral awareness comes from the clarity of the mind and by looking beyond social stakes, such as personal relationships to eliminate subjectivity and bias. Friesenbichler et al<sup>101</sup> found that managers with higher work engagement are more likely to be aware of and perceive the inauthentic and corrupt elements in work-related inquiries. Their study attributes the awareness to the freed cognitive resources, and associates it with the ability to find alternative ways of acting and solving dilemmas as well as not engaging in “easy” and corrupt alternatives in achieving goals. One can also take a look at the role of goal-setting in influencing unethical behavior. According to Barsky,<sup>102</sup> wearing goals have the effect of increasing moral disengagement and decreasing ethical recognition, thus resulting in blindness towards ethical consequences. Ordóñez and Welsh<sup>103</sup> suggested that the negative impact of highly demanding goals can be eliminated by increasing an individual’s moral awareness, for example through ethical priming.

The limitation of this study is that this research has not explored the distinction between functionalist and social-adaptive perspectives on guilt and shame, as suggested by Dempsey.<sup>104</sup> This differentiation may be able to clarify how the effects of counterfeit behavior in cultural diversity that treats the two perspectives with different weights.

## Conclusion

This present study has proven that all counterfeit behaviors have disrupted the inauthenticity of a person. Although Study 1 and Study 2 do not directly analyze the relationships between counterfeit behaviors and the actual corruption act, they do suggest ways we can look at early signs and prediction of corruption tendencies.

Counterfeit behavior empirically leads to disruption of a person’s true self that ends with lower moral emotions/GASP (or a higher corruption tendencies). The implication of this study is that neither our personal counterfeit behavior nor that of our society can be disregarded as this behavior progressively disrupts sound human morals. Disregarding counterfeit behavior implies that we are contributing to the crime of corruption. Corruption is not merely an individual responsibility but rather a social responsibility as society itself is considered a seductive environment for the occurrence of counterfeit behavior, especially in this 4.0 Industry era.

## Author Contributions

All authors made a significant contribution to the work reported, whether that is in the conception, study design, execution, acquisition of data, analysis and interpretation, or in all these areas; took part in drafting, revising or critically reviewing the article; gave final approval of the version to be published; have agreed on the journal to which the article has been submitted; and agree to be accountable for all aspects of the work.

## Disclosure

The authors report no conflicts of interest in this work.

## References

1. Rosenstand CAF, Gertsen F, Vesti H. A definition and a conceptual framework of digital disruption. *Proceedings of the XXIX ISPIM Innovation Conference - Innovation, The Name of The Game*; June 17-20 2018; Stockholm, Sweden: ISPIM; 2018. Available from: [https://vbn.aau.dk/files/287480228/A\\_definition\\_and\\_a\\_conceptual\\_framework\\_of\\_digital\\_disruption.pdf](https://vbn.aau.dk/files/287480228/A_definition_and_a_conceptual_framework_of_digital_disruption.pdf).

2. Millar C, Lockett M, Ladd T. Disruption: technology, innovation and society. *Technol Forecast Soc Change*. 2018;129:254–260. doi:10.1016/j.techfore.2017.10.020
3. Kilkki K, Mäntylä M, Karhu K, Hämmäinen H, Ailisto H. A disruption framework. *Technol Forecast Soc Change*. 2018;129:275–284. doi:10.1016/j.techfore.2017.09.034
4. Kamble P. Coping with IT disruptions - with Behavioral IT<sup>®</sup> skills. *Proceedings of National e-Conference 2020 on The Role of Management Practices in Business Sustainability in an Era of Technology Disruptions*; Gujarat, India: IJSRSET; 2020. doi:10.2139/ssrn.3715359.
5. Eggers JP, Park KF. Incumbent adaptation to technological change: the past, present, and future of research on heterogeneous incumbent response. *Acad Manag Ann*. 2018;12(1):357–389. doi:10.5465/annals.2016.0051
6. Riemer K. How we adapt to digital disruption. The University of Sydney; 2017. Available from: [https://www.sydney.edu.au/news-opinion/news/2017/10/04/how-we-adapt-to-digital-disruption.html#uniqueId\\_cqDpYbbg\\_0\\_button](https://www.sydney.edu.au/news-opinion/news/2017/10/04/how-we-adapt-to-digital-disruption.html#uniqueId_cqDpYbbg_0_button). Accessed February 26, 2022.
7. Schade EC, Voracek M, Tran US. The nexus of the dark triad personality traits with cyberbullying, empathy, and emotional intelligence: a structural-equation modeling approach. *Front Psychol*. 2021;12:659282. doi:10.3389/fpsyg.2021.659282
8. Juneman J. Pencegahan dan penanggulangan penyalahgunaan napza dengan pendekatan psikologi sosial [Drug abuse prevention and control with social psychology approach]. *Psikol Plus*. 2009;4(3):61–78.
9. Keen A. *The Internet is Not the Answer*. London, UK: Atlantic Books Ltd; 2015.
10. Wognum N, Wever M, Stjepandić J. Managing risks in knowledge exchange: trade-offs interdependencies. In: Borsato M, editor. *Transdisciplinary Engineering: Crossing Boundaries (Advances in Transdisciplinary Engineering Ebook, Volume 4)*. Amsterdam, Netherlands: IOS Press; 2016:15–24. doi:10.3233/978-1-61499-703-0-15
11. Chesney R, Citron DK. Deep fakes: a looming challenge for privacy, democracy, and national security. *Cal L Rev*. 2019;107:1753–1820.
12. Cahr D, DeBella T. Tech brings authentication challenges in ad and IP cases. *Law360*; 2019. Available from: <https://www.law360.com/articles/1135347/tech-brings-authentication-challenges-in-ad-and-ip-cases>. Accessed February 26, 2022.
13. FranklinCovey. Counterfeiting your culture. FranklinCovey; 2018. Available from: <https://resources.franklincovey.com/mkt-sotv1/counterfeiting-your-culture>. Accessed February 26, 2022.
14. Green C. Books we trust: the speed of trust. *Social Media Today*; 2011. Available from: <https://www.socialmediatoday.com/content/books-we-trust-speed-trust>. Accessed February 26, 2022.
15. FranklinCovey. The speed of trust<sup>®</sup>: building strong teams and relationships at work - toolkit. FranklinCovey; 2011. Available from: [https://support.liveclicks.com/cc\\_files/ex/misc\\_resources/relationshipTrustToolkit.pdf](https://support.liveclicks.com/cc_files/ex/misc_resources/relationshipTrustToolkit.pdf). Accessed February 26, 2022.
16. FranklinCovey. Achieving new results in a new reality. FranklinCovey; 2020. Available from: [https://www.franklincovey.com/wp-content/uploads/2020/10/unpredictable\\_\\_new\\_AchievingANewReality\\_.pdf](https://www.franklincovey.com/wp-content/uploads/2020/10/unpredictable__new_AchievingANewReality_.pdf). Accessed February 26, 2022.
17. Abraham J, Takwin B, Suleeman J. Counterfeit self: a confirmatory factor analysis among Indonesians. *Kasetsart J Soc Sci*. 2018;39(3):518–525. doi:10.1016/j.kjss.2017.07.011
18. Frost SA. *Frost's Laws and By-Laws of American Society*. Germany: Salzwasser Verlag GmbH; 2020.
19. Abraham J, Suleeman J, Takwin B. The psychology of corruption: the role of the counterfeit self, entity self-theory, and outcome-based ethical mindset. *J Psychol Educ Res*. 2018;26(2):7–32.
20. Zaloznaya M. The social psychology of corruption: why it does not exist and why it should. *Sociol Compass*. 2014;8(2):187–202. doi:10.1111/soc4.12120
21. Behera NK. The different types of corruption. India Study Channel; 2014. Available from: <http://www.indiastudychannel.com/resources/138785-The-different-types-Corruption.aspx>. Accessed February 26, 2022.
22. Moore C. Psychological processes in organizational corruption. In: De Cremer D, editor. *Psychological Perspectives on Ethical Behavior and Decision Making*. North Carlina, US: Information Age Publishing, Inc; 2009:35–71.
23. Furukawa Y, Nakashima K, Tsukawaki R, Morinaga Y. Guilt as a signal informing us of a threat to our morality. *Curr Psychol*. 2021;40:2122–2132. doi:10.1007/s12144-019-0144-4
24. Griffin E. *A First Look at Communication Theory*. 8th ed. New York, US: McGraw-Hill; 2012.
25. Abraham J, Pea AG. Can proneness to moral emotions detect corruption? The mediating role of ethical judgment based on unified ethics. *Kasetsart J Soc Sci*. 2020;41(1):152–159. doi:10.1016/j.kjss.2018.07.013
26. Cohen TR, Wolf ST, Panter AT, Insko CA. Introducing the GASP scale: a new measure of guilt and shame proneness. *J Pers Soc Psychol*. 2011;100(5):947–966. doi:10.1037/a0022641
27. Gino F, Norton MI, Ariely D. The counterfeit self: the deceptive costs of faking it. *Psychol Sci*. 2010;21(5):712–720. doi:10.1177/0956797610366545
28. Knoll M, Lord RG, Petersen LE, Weigelt O. Examining the moral grey zone: the role of moral disengagement, authenticity, and situational strength in predicting unethical managerial behavior. *J Appl Soc Psychol*. 2015;46(1):65–78. doi:10.1111/jasp.12353
29. Stolorow R. Toward greater authenticity: from shame to existential guilt, anxiety, and grief. *Int J Psychoanal Self Psychol*. 2011;6(2):285–287. doi:10.1080/15551024.2011.552411
30. Chandran N. South Korea's Park swept up in political storm. CNBC; 2015. Available from: <http://www.cnbc.com/2015/04/17/south-koreas-park-swept-up-in-political-storm.html>. Accessed February 26, 2022.
31. Joyce C. Japan minister's suicide over corruption inquiry. Telegraph; 2007. Available from: <http://www.telegraph.co.uk/news/worldnews/1552942/Japan-ministers-suicide-over-corruption-inquiry.html>. Accessed February 26, 2022.
32. Yoshida R. How Japanese tax-payers' money is lost in Bid-rigging. The Japan Times; 2007. Available from: <https://www.japantimes.co.jp/news/2007/07/03/reference/how-japanese-tax-payers-money-is-lost-in-bid-rigging/>. Accessed February 26, 2022.
33. Abraham J, Gunawan H. Moral emotions, income sufficiency, family self-sufficiency, and selflessness. *Proceedings of SGEM2014 Proceedings (Book 1, Vol. 1, 241–248)*; Sofia, Bulgaria: STEF92 Technology Ltd; 2014. doi:10.5593/sgemsocial2014/B11/S1.032.
34. Abraham J, Pane MM. Corruptive tendencies, conscientiousness, and collectivism. *Procedia Soc Behav Sci*. 2014;153:132–147. doi:10.1016/j.sbspro.2014.10.048
35. Abraham J, Suleeman J, Takwin B. Psychological mechanism of corruption: a comprehensive review. *Asian J Sci Res*. 2018;11(4):587–604. doi:10.3923/ajsr.2018.587.604
36. Tracy JL, Robins RW, Tangney JP. *The Self-Conscious Emotions: Theory and Research*. New York, US: Guilford Press; 2007.



37. Moore C, Detert JR, Klebe Treviño L, Baker VL, Mayer DM. Why employees do bad things: moral disengagement and unethical organizational behavior. *Pers Psychol.* 2012;65(1):1–48. doi:10.1111/j.1744-6570.2011.01237.x
38. Detert JR, Treviño LK, Sweitzer VL. Moral disengagement in ethical decision making: a study of antecedents and outcomes. *J Appl Psychol.* 2008;93(2):374–391. doi:10.1037/0021-9010.93.2.374
39. Feist J, Feist GJ. *Theories of Personality.* 7th ed. New York, US: McGraw-Hill; 2008.
40. Wood AM, Linley PA, Maltby J, Baliousis M, Joseph S. The authentic personality: a theoretical and empirical conceptualization and the development of the authenticity scale. *J Couns Psychol.* 2008;55(3):385–399. doi:10.1037/0022-0167.55.3.385
41. Baumeister RF, Bushman BJ, Campbell WK. Self-esteem, narcissism, and aggression: does violence result from low self-esteem or from threatened egotism? *Curr Dir Psychol Sci.* 2000;9(1):26–29. doi:10.1111/1467-8721.00053
42. Johnson JF, Connelly S. Moral disengagement and ethical decision-making: the moderating role of trait guilt and shame. *J Pers Psychol.* 2016;15(4):184–189. doi:10.1027/1866-5888/a000166
43. Page TE, Pina A, Giner-Sorolla R. “It was only harmless banter!”: the development and preliminary validation of the moral disengagement in sexual harassment scale. *Aggress Behav.* 2016;42(3):254–273. doi:10.1002/ab.21621
44. Newman GE, Bloom P, Knobe J. Value judgments and the true self. *Pers Soc Psychol Bull.* 2014;40(2):203–216. doi:10.1177/0146167213508791
45. Gino F, Kouchaki M, Galinsky AD. The moral virtue of authenticity: how inauthenticity produces feelings of immorality and impurity. *Psychol Sci.* 2015;26(7):983–996. doi:10.1177/0956797615575277
46. Schmid PF. Authenticity: the person as his or her own author - dialogical and ethical perspectives on therapy as an encounter relationship - and beyond. In: Wyatt G, editor. *Rogers' Therapeutic Conditions: Evolution, Theory and Practice (Vol. 1: Congruence.* Ross-on-Wye, UK: PCCS Books; 2001:217–232.
47. Kernis MH, Goldman BM. A multicomponent conceptualization of authenticity: theory and research. *Adv Exp Soc Psychol.* 2006;38:283–357. doi:10.1016/S0065-2601(06)38006-9
48. Rae G. Alienation, authenticity and the self. *Hist Hum Sci.* 2010;23(4):21–36. doi:10.1177/0952695110375763
49. Newman GE, De Freitas J, Knobe J. Beliefs about the true self explain asymmetries based on moral judgment. *Cogn Sci.* 2015;39(1):96–125. doi:10.1111/cogs.12134
50. Clark GL. The anatomy of corruption: the practice of pension fund trustee decisionmaking. *Environ Plan a Econ Space.* 1998;30(7):1235–1253. doi:10.1068/a301235
51. Weber M. Consciousness and rationality. In: Weber M, Weekes A, editors. *Process Approaches to Consciousness in Psychology, Neuroscience, and Philosophy of Mind.* New York, US: SUNY Press; 2009:345–386.
52. Chiou WB, Wan PH, Wan CS. A new look at software piracy: soft lifting primes an inauthentic sense of self, prompting further unethical behavior. *Int J Hum Comput Stud.* 2012;70(2):107–115. doi:10.1016/j.ijhcs.2011.09.001
53. Amankwah-Amoah J, Antwi-Agyei I, Zhang H. Integrating the dark side of competition into explanations of business failures: evidence from a developing economy. *Eur Manage Rev.* 2017;15(1):97–109. doi:10.1111/emre.12131
54. Taylor A. The next generation: technology adoption and integration through internal competition in new product development. *Organ Sci.* 2010;21(1):23–41. doi:10.1287/orsc.1080.0399
55. Bauer T. Can we ever kill silo thinking? (Likely not.). The Context of Things; 2017. Available from: <https://thecontextofthings.com/2017/07/27/silo-thinking/>. Accessed February 26, 2022.
56. Ballor JJ. Plagiarism in a digital age. *J Mark Moral.* 2014;17(2):349–352.
57. Macnamara J. Toward a theory and practice of organizational listening. *Int J List.* 2017;32(1):1–23. doi:10.1080/10904018.2017.1375076
58. Anton C. Technology, hypocrisy and morality: where, oh where, has all the hypocrisy gone? *Explor Media Ecol.* 2018;17(2):119–135. doi:10.1386/eme.17.2.119\_1
59. Kotekar V. A study of deviant workplace behavior and withdrawal intentions in education sector. *Arts Educ Int Res J.* 2017;4(1):67–72.
60. Wiseman R. *Queen Bees & Wannabes.* 3rd ed. New York, US: Harmony; 2016.
61. Malone P, Hayes J. Backstabbing in organizations: employees' perceptions of incidents, motives, and communicative responses. *Commun Stud.* 2012;63(2):194–219. doi:10.1080/10510974.2011.635552
62. McKenna E. *Business Psychology and Organisational Behaviour.* 6th ed. London, UK: Routledge; 2020.
63. Ferro MJ, Martins HF. Academic plagiarism: yielding to temptation. *Br J Educ Soc Behav Sci.* 2016;13(1):1–11. doi:10.9734/BJESBS/2016/20535
64. Taylor DG. Plagiarism in the digital world. Luxemburg: Sacred Heart University; 2016. Available from: <https://www.shu.lu/plagiarism-digital-world/>. Accessed February 26, 2022.
65. Statt N. Fuckjerry founder apologizes for stealing jokes and pledges to get creator permission. The Verge; 2019. Available from: <https://www.theverge.com/2019/2/2/18208446/fuckjerry-elliott-tebele-meme-joke-aggregator-repost-new-policy-change>. Accessed February 26, 2022.
66. Howard RM, Watson M. The scholarship of plagiarism: where we've been, where we are, what's needed next. *Writing Prog Adm.* 2010;33(3):116–124.
67. McCormack S. *Reflect and Relate: An Introduction to Interpersonal Communication.* 2nd ed. Massachusetts, US: Bedford/St. Martin's; 2010.
68. Wood JT. *Interpersonal Communication: Everyday Encounters.* 8th ed. Massachusetts, US: Wadsworth-Cengage Learning; 2016.
69. Pearse M, Dunwoody M. *Learning That Never Ends: Qualities of a Lifelong Learner.* Maryland, US: R&L Education; 2013.
70. Rosen J. Listen like you mean it. HuffPost; 2015. Available from: [https://www.huffpost.com/entry/listen-like-you-mean-it\\_b\\_6136092](https://www.huffpost.com/entry/listen-like-you-mean-it_b_6136092). Accessed February 26, 2022.
71. Hargie O. *Skilled Interpersonal Interaction: Research, Theory, and Practice.* 6th ed. London, UK: Routledge; 2011. DOI:10.4324/9781315741901
72. Bariso J. Elon Musk tries to avoid having meetings at Tesla - and encourages people to leave if they're not adding any value. Insider; 2020. Available from: <https://www.businessinsider.com/elon-musk-3-rules-running-better-meetings-like-having-less-2019-8?IR=T>. Accessed February 26, 2022.

73. Leheney M. The people side of leadership: an overlooked opportunity. *Public Manager*. 2008;37(2):15–18.
74. Encyclopaedia Britannica. Pancasila. Encyclopædia Britannica, Inc; 2021. Available from <https://www.britannica.com/topic/New-Nationalism>. Accessed February 26, 2022.
75. BBC Indonesia. Sidang perdana, Ratu Atut tidak ajukan nota keberatan [First trial, Ratu Atut did not file a note of objection]. BBC Indonesia; 2014. Available from: [http://www.bbc.com/indonesia/berita\\_indonesia/2014/05/140506\\_ratuatut\\_sidang\\_perdana](http://www.bbc.com/indonesia/berita_indonesia/2014/05/140506_ratuatut_sidang_perdana). Accessed February 26, 2022.
76. Djohan M. Ratu Atut kerap sibuk kampanye antikorupsi dan agama [Ratu Atut is often busy with anti-corruption and religious campaigns]. Tempo.co; 2013. Available from: <https://foto.tempo.co/read/10392/ratu-atut-kerap-sibuk-kampanye-antikorupsi-dan-agama>. Accessed February 26, 2022.
77. Firdaus F. Suryadharma Ali divonis 6 tahun penjara [Suryadharma Ali sentenced to 6 years in prison]. Rappler; 2016. Available from: <https://r3.rappler.com/indonesia/118621-vonis-suryadharma-ali-kasus-haji>. Accessed February 26, 2022.
78. Ibrahim IS. Dunia simbolik dan Gaya hidup dalam beragama: Dari ideologisasi ke komersialisasi spiritualitas [The symbolic world and lifestyle in religion: from ideological to commercialization of spirituality]. *Mediator*. 2002;3(1):25–30. doi:10.29313/mediator.v3i1.745
79. Wollschleger J, Beach L. A cucumber for a cow: a theoretical exploration of the causes and consequences of religious hypocrisy. *Rational Soc*. 2011;23(2):155–174. doi:10.1177/1043463111404673
80. Abranches A. Can hypocrisy be a virtue? Hume on the morality of princes. *Ethics Politics Soc*. 2019;2:139–154. doi:10.21814/eps.2.1.89
81. McDermott ML, Schwartz D, Vallejo S. Talking the talk but not walking the walk: public reactions to hypocrisy in political scandal. *Am Politics Res*. 2015;43(6):952–974. doi:10.1177/1532673X15577830
82. Graafland J. Religiosity, attitude, and the demand for socially responsible products. *J Bus Ethics*. 2017;144(1):121–138. doi:10.1007/s10551-015-2796-9
83. Van den Broeck E, Poels K, Walrave M. Older and wiser? Facebook use, privacy concern, and privacy protection in the life stages of emerging, young, and middle adulthood. *Soc Media Soc*. 2015;1(2):1–11. doi:10.1177/2056305115616149
84. Akkuş A. Developing a scale to measure students' attitudes toward science. *Int J Assess Tools Educ*. 2019;6(4):706–720. doi:10.21449/ijate.548516
85. Abraham J, Berline R. An investigation on organizational charlatan behaviour and moral identity as predictors of shame: importance for education. *J Educ Learn*. 2015;9(2):135–144. doi:10.11591/edulearn.v9i2.1535
86. Howard SJ, Ehrich JF, Walton R. Measuring students' perceptions of plagiarism: modification and Rasch validation of a plagiarism attitude scale. *J Appl Meas*. 2014;15(4):372–393.
87. Stinson B. Fake listening. Barney Stinson Blog; 2013. Available from: <https://www.barneystinsonblog.com/fake-listening/>. Accessed February 26, 2022.
88. Listen and lead. Fake listening. Listen and lead; 2008. Available from: <https://jobspage.typepad.com/listenandlead/2008/11/fake-listening.html>. Accessed February 26, 2022.
89. Drollinger T, Comer LB, Warrington P. Development and validation of the active empathetic listening scale. *Psychol Mark*. 2006;23(2):161–180. doi:10.1002/mar.20105
90. Huber S, Huber OW. The centrality of religiosity scale (CRS). *Religions*. 2012;3(3):710–724. doi:10.3390/rel3030710
91. Hofmann W, Wisneski DC, Brandt MJ, Skitka LJ. Morality in everyday life. *Science*. 2014;345(6202):1340–1343. doi:10.1126/science.1251560
92. Stacey A. Reframing plagiarism in Academia 4.0. *Proceedings of 18th European Conference on Research Methodology for Business and Management Studies, ECRM*; Johannesburg, South Africa: ACPL; 2019. doi:10.34190/RM.19.068.
93. Wanschers MEA. Toward 'industry 4.0' and team effectiveness: best practices of employees of a transitioning organisation [thesis]. Enschede, Netherlands: Department of Business Administration, Faculty of Behavioral, Management and Social Sciences, University of Twente; 2018. Available from: [http://essay.utwente.nl/75928/1/Wanschers\\_BA\\_BMS.pdf](http://essay.utwente.nl/75928/1/Wanschers_BA_BMS.pdf). Accessed February 26, 2022.
94. Kuipers G, Franssen T, Holla S. Clouded judgments? Aesthetics, morality and everyday life in early 21st century culture. *Eur J Cult Stud*. 2019;22(4):383–398. doi:10.1177/1367549419861634
95. White GM. Affecting culture: emotion and morality in everyday life. In: Kitayama S, Markus HR, editors. *Emotion and Culture: Empirical Studies of Mutual Influence*. Washington, DC: American Psychological Association; 1994:219–239. doi:10.1037/10152-006
96. Mullen E, Monin B. Consistency versus licensing effects of past moral behavior. *Annu Rev Psychol*. 2016;67(1):363–385. doi:10.1146/annurev-psych-010213-115120
97. Ellemers N, van der Toorn J, Paunov Y, van Leeuwen T. The psychology of morality: a review and analysis of empirical studies published from 1940 through 2017. *Pers Soc Psychol Rev*. 2019;23(4):332–366. doi:10.1177/1088868318811759
98. De Simone S. The affective component of workplace in organizational behavior studies. *Am Int J Contemp Res*. 2014;4(9):38–43.
99. de Vries MF. A tale of two organizations: creating the authentizotic organization INSEAD Working Paper No. 2017/64/EFE; 2017. doi:10.2139/ssrn.3045179.
100. Baron P. A cybernetic approach to contextual teaching and learning. *Constr Found*. 2016;12(1):91–100.
101. Friesenbichler KS, Selenko E, Clarke G. Perceptions of corruption: an empirical study controlling for survey bias. *J Interdiscip Econ*. 2018;30(1):55–77. doi:10.1177/0260107917723787
102. Barsky A. Understanding the ethical cost of organizational goal-setting: a review and theory development. *J Bus Ethics*. 2008;81(1):63–81. doi:10.1007/s10551-007-9481-6
103. Ordóñez LD, Welsh DT. Immoral goals: how goal setting may lead to unethical behavior. *Curr Opin Psychol*. 2015;6:93–96. doi:10.1016/j.copsyc.2015.06.001
104. Dempsey H. A comparison of the social-adaptive perspective and functionalist perspective on guilt and shame. *Behav Sci*. 2017;7(4):83. doi:10.3390/bs7040083

## Psychology Research and Behavior Management

Dovepress

### Publish your work in this journal

Psychology Research and Behavior Management is an international, peer-reviewed, open access journal focusing on the science of psychology and its application in behavior management to develop improved outcomes in the clinical, educational, sports and business arenas. Specific topics covered in the journal include: Neuroscience, memory and decision making; Behavior modification and management; Clinical applications; Business and sports performance management; Social and developmental studies; Animal studies. The manuscript management system is completely online and includes a very quick and fair peer-review system, which is all easy to use. Visit <http://www.dovepress.com/testimonials.php> to read real quotes from published authors.

Submit your manuscript here: <https://www.dovepress.com/psychology-research-and-behavior-management-journal>