

Effects of Cold Periods on the Stimulus-Response System of *Phycomyces*

M. PETZUCH and M. DELBRÜCK

From the Division of Biology, California Institute of Technology, Pasadena, California 91109.
Dr. Petzuch's present address is Centre National de la Recherche Scientifique, Centre de
Génétique Moléculaire, 91-Gif-sur-Yvette, France.

ABSTRACT The sporangiophores of *Phycomyces* do not exhibit phototropic responses when growth is arrested reversibly by cooling to 1°C. Unilateral UV stimuli (254 nm) applied during cold periods are stored for at least 2 hr and produce tropic responses away from the light after warm-up. During the cold period dark adaptation proceeds at a rate which decreases with the temperature.

INTRODUCTION

Phycomyces sporangiophores respond to various stimuli by changes in growth rate. These responses cannot occur if growth is temporarily arrested, for instance by cooling the sporangiophores to a temperature near 0°C. Will a stimulus given during such a cold period be stored in some form and give a response after warming up?

Sporangiophores which have been adapted to a certain ambient light intensity will be unresponsive to light stimuli involving smaller intensities unless they have first been dark-adapted; i.e., kept for a sufficient period in the presence of a correspondingly lower ambient intensity or in complete darkness. This process of dark adaptation can be quantitated, and its kinetics have previously been worked out (Delbrück and Reichardt, 1956). Over a fairly wide range the level of dark adaptation, A , decreases exponentially in the dark, with a time constant of a few minutes at room temperature. Here, we may ask the question: Does the *Phycomyces* sporangiophore dark-adapt near 0°C though it cannot grow, and what are the kinetics?

An attempt to answer the first question has been published in a short note by Ebrey and Clayton (1969). The principal deficiencies of their pioneering experiments are the poor temperature and humidity control, the failure to measure the temperature, the shortness of the cold periods, and the lack of certain controls, especially concerning the effects of cold periods without light stimuli. The present investigations were undertaken in an attempt to remedy these deficiencies.

The questions are of great intrinsic interest. A long-term storage of intermediates in the chain leading from a light stimulus to a growth response might permit us to break into this chain with chemical approaches, to relate such intermediates to those occurring in the case of other stimulus qualities (stretch, gravity, chemical), and to assess the nature of the defects of mutants. The temperature dependence of the rate of dark adaptation may give a hint regarding the type of reactions involved.

METHODS AND MATERIALS

General Considerations Concerning Instrumental Design

TEMPERATURE AND HUMIDITY We wish to cool our specimen to a temperature low enough so that metabolism is at a very low rate yet not so low that irreversible damage occurs. We may reasonably define the physiological range as that in which growth occurs at a still measurable rate. As will be seen from Table I a temperature of 1°C seems a reasonable choice.

We want to cool down and to warm up our specimen as quickly as possible for two reasons: to have programs well-defined with respect to time, and in the hope that a fast cool-down may arrest metabolism sufficiently fast to prevent physiological alterations and similarly that a fast warm-up may bring the specimen back to the original state.

In order to cool a sporangiophore standing in air of room temperature, one can either replace the air by cold air (not colder than 1°C) or cool the enclosing wall or do both. On cooling, the sporangiophore loses heat by convection, by radiation, and by transpiration. When the air is replaced, convection produces the fastest heat loss of the sporangiophore and calculation shows that the specimen is cooled within a

TABLE I
GROWTH RATES AT DIFFERENT TEMPERATURES

v	n	T	t_C	t_{st}	L	ΔL	v_C	r.h.
mm/hr		°C	hr	min	mm	mm	mm/hr	
2.3	13	7.2±0.3	12.1	30	10.8	±3.3	0.89	Low
2.2	15	5.3±0.3	6.2	30	2.2	±0.8	0.35	
2.2	15	4.6±0.1	7.0	30	2.0	±1.0	0.29	
2.0	16	3.8±0.2	13.1	30	2.0	±1.5	0.15	
2.3	22	3.0	20.3	60	5.5	±2.5	0.27	High
3.0	19	1.8	24.1	30	4.4	±2.6	0.18	
2.6	25	1.0	49.8	50	1.0	±0.5	0.02	

v , average growth rate at about 24°C.

n , number of sporangiophores in one experiment.

T , temperature, given by thermistor, stationary value.

t_C , time in refrigerator.

t_{st} , time at which stationary temperature value is reached.

L , average increase in length.

ΔL , maximum deviation of L .

v_C , average growth rate in refrigerator = L/t_C .

r.h., relative humidity.

fraction of a minute but not within a second. However, the walls surrounding the sporangiophore are also cooled by the air. This heat gain from the walls leads to a final value of the air temperature higher than 1°C. Cooling only the walls would result in a poorly defined relative humidity (r.h.) after warming up. For example, if we started with 60% r.h. at room temperature, the r.h. at 1°C would be 100% and the excess of water would precipitate. Upon warming up we would have 25% r.h. and a slow increase by evaporation.

Therefore we decided to design a chamber that would hold humidity at reasonable levels both for near room temperature and for cold periods. This can be done by percolating a continuous stream of air of proper temperature and r.h. through the chamber. We further decided to change the air temperature by switching from a room temperature air supply to a cold air supply and vice versa, and also to change the wall temperature.

TYPE OF STIMULATION Tropic responses to unilateral UV light ($\lambda < 300$ nm) are by far the most conspicuous responses obtainable. Qualitatively they are not affected by fluctuations in growth rate, which do occur after cold periods as will be seen (Fig. 4). One specimen can be used for several tests, if short and sufficiently small stimuli are used. Therefore we decided to work with short, unilateral UV stimuli.

Actual Instrumental Design

CHAMBER FOR CONTROLLED TEMPERATURE AND HUMIDITY CHANGES The actual design of the chamber for controlled temperature and humidity changes is shown in Fig. 1. Warm or cold air enters the chamber at a flow rate of 135 cc/sec. Constant absolute humidity of the two air supplies is maintained by blowing warm air (21°C) through a saturated solution of NaCl kept at 21°C (r.h. = 75.5%) and by blowing cold air (0°C) through distilled water kept at 0°C (r.h. 100%). We use water (near room temperature = "warm") or water plus ethylene glycol (near 0°C = "cold") to control the temperature of the chamber wall. The water and the water plus ethylene glycol are recirculated at a flow rate of about 5 liters/min. We switch from one supply to the other to change the wall temperature.

The following correlation existed between the temperature, T_w , of the water and ethylene glycol, and the air temperature, T_c , in the chamber (measured with a thermistor, cold air passing through the chamber at the same time):

T_w °C	T_c °C
1.8	4.0
0	2.9
-2.0	1.3

The temperature of the air and water supplies and the flow rates chosen determine the steady-state temperature at the sporangiophore. The rate of temperature change is determined by the appropriate manipulation of the switches. In cooling down from room temperature to 1°C the chamber air temperature was 8°C within 1.5 min. The final value was reached 10 min after the start of cooling. This is not the

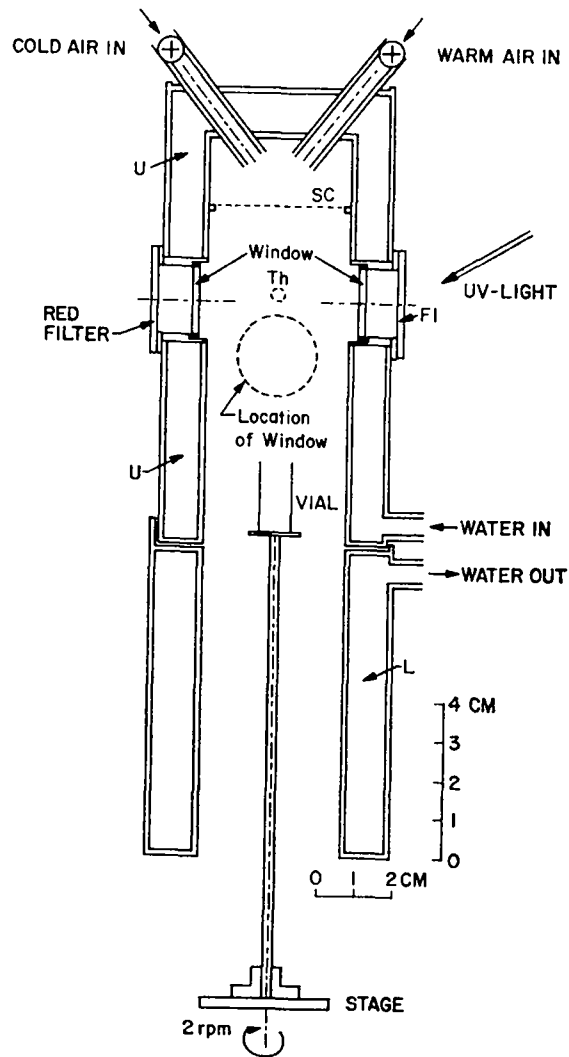

FIGURE 1. Vertical cross-section of the cylindrical metal chamber for controlled temperature and humidity changes. Water flows through the upper part of the water jacket, *U*, and the lower part, *L*, in tandem. Warm or cold air enters through one of the valves on top, which can be switched to bypass or entry into the chamber. The airflow is smoothed out by a screen, *SC*. The air leaves the chamber through its open bottom. The temperature is measured by a thermistor at *Th*. This temperature sensor enters horizontally on the far side of the chamber. The chamber has four windows, right and left, front and back. In order to obtain windows of small heat conduction and small heat capacity they are made of two layers of glass separated by copper spacers. The complete double window is 2 mm thick. The windows are held in their round openings by silicon grease. The light entering the windows is controlled by filters. Light for adaptation and stimulation of the sporangiophore passes through the right window (quartz). The filter, *Fl*, is UV-transparent and nearly opaque to visible light (Corning, 7-54). (The left window was built for a second light source, but was not used in the experiments here reported.) The back window is used for red light illumination and the front window for observing the movements of the sporangiophore. Heating resistors ($4w$) are attached to the filters on the viewing window and on *Fl* to prevent precipitation of moisture during cooling experiments. A layer of moisture would fog the filters. The chamber allows the observer to sit in room light, while the specimen is exposed to a defined light program.

fastest possible cooling. The procedure was chosen in the hope of preventing irreversible damage to the sporangiophore. Stimuli were given after the final temperature had been reached. From the recorded temperature and the known absolute humidity one can calculate the r.h. During cooling to 1°C the humidity passed through supersaturation, then fell rapidly to 30–60%, and then rose gradually to 94% (1°C), 71% (5°C), or 61% (7°C). Warming up to room temperature was completed within 1 min. During warming up from 1°C the humidity around the sporangiophore fell gradually to a lower value of 30–40%, then rose quickly to around saturation, and fell gradually to its final value.

TEMPERATURE MEASUREMENTS Temperatures were measured by a bead thermistor (Fenwal Electronics, Inc. [Framingham, Mass.] $2\text{ k}\Omega \pm 15\%$ at 25°C; time constant 1 sec; dissipation constant 0.1 mw in still air). The ratio of resistance at 0°C to the resistance at 50°C is 5.7. This ratio determines the sensitivity of the thermistor for measuring temperature changes. Although thermistors of higher sensitivity are available, units with faster responses were preferred despite their lower sensitivity. The change in the resistance of the thermistor caused by a change in temperature was measured by a Wheatstone bridge (resistance on opposite side of thermistor 30 k Ω , voltage 0.75 v). The thermistor is brought into position by inserting it through a tube into the chamber. The chart recorder is calibrated in degrees centigrade by putting the thermistor into water of different temperatures, measured with an accuracy of $\pm 0.1^\circ\text{C}$.

UV LIGHT SOURCE A low pressure mercury lamp (General Electric germicidal lamp G4T4/1) of 4 nominal w was used. The lamp is rated to emit 50% of the input energy at 253.7 nm, 2% in the visible and 48% as heat. About 5 mm from the bulb of the mercury lamp is a circular diaphragm of about 2 mm diameter, which drastically reduces the radiation flux to which the sporangiophore is exposed. The diaphragm is located in the focus of a quartz lens. The diameter of the nearly parallel light bundle leaving the quartz lens is about 18 mm. It enters the chamber at 30° above the horizontal.

The 7-54 filter in front of the right window is not only transparent in the UV and near blue, but also in the infrared. A nickel-cobalt sulfate solution similar to that used by Delbrück and Varju (1961) absorbs some of this light. It was checked that the heat emitted by the UV lamp was in the range in which the filter 7-54 is not transparent. When necessary a neutral density filter on Herasil-quartz is used in front of the UV-transmitting filter. The nominal transmission of the filters used was 10 and 1%. The actual transmission at 254 nm was 6.4 and 0.22%, respectively, because the filter changes its transmission near 250 nm.

The UV radiation flux (FU) entering the chamber was estimated to be $1.7\ \mu\text{w}/\text{cm}^2 < \text{FU} < 3.1\ \mu\text{w}/\text{cm}^2$, using a phototube (RCA 935). The physiologically equivalent radiation flux of broad band blue light (Bergman et al., 1969) is about five times larger. According to Delbrück and Varju (1961) UV light of the above intensity is just too low to damage the specimen, even if applied for a sustained period.

STAGE FOR MOUNTING OF SPECIMEN The vial with the specimen is placed on a stage which can be rotated at 2 rpm by a synchronous motor drive. The stage can

be moved by fine movements in all three directions. The table supporting the vial can be moved relative to the stage in the two horizontal directions. Thus, the growing zone can be brought to and kept on the axis of rotation during experiments.

CULTURE CONDITIONS *Phycomyces blakesleeanus* strain 1555 (—) of the Northern Regional Research Laboratory, Peoria, Ill., was used throughout.

In order to keep the heat capacity effects minimal, cultures were grown in small shell vials 1.8 cm long, 0.8 cm in diameter, and filled with agar to between one-fourth and one-third of their height. The length of the stage IVb sporangiophores used was 2–4 cm at the beginning of the experiments. The diameters of the sporangiophores measured 0.5 mm below the sporangium ranged from 85–100 μ . The growth rate at room temperature was 1.5–3.0 mm/hr.

EXPERIMENTS

Growth Rates at Different Temperatures

In order to determine the lower end of the physiological temperature range the growth rates of sporangiophores were measured on specimens held in an open or closed styrofoam box placed inside a refrigerator for many hours. The results are given in Table I. The temperature column gives the variation in temperature in the open box. For the closed box no changes in temperature were detectable (accuracy $\pm 0.1^\circ\text{C}$). As the maximum deviation, ΔL , is only 50% of L for 1°C , we conclude that at 1°C growth is still detectable. The growth rate appears to be somewhat higher at high r.h. than at low r.h.

Stimulus Storage and Dark Adaptation Kinetics

OUTLINE OF PROGRAMS The lower temperature was about 11° , 7° , 5° , or 1°C in various series. For *storage* experiments a unilateral UV stimulus was given before or during the cold period, or, as a control, after warming up. Before the stimulus was given the sporangiophore was adapted by rotation in the presence of a certain light intensity. The stimulus was applied by stopping rotation for a certain time in the presence of the same or a higher light intensity. After the stimulus the sporangiophore was kept in darkness. As a control the sporangiophore was adapted in the same light intensity as in the experiment; no stimulus was given; after adaptation the sporangiophore was kept in darkness. For *dark adaptation* experiments the beginning of dark adaptation was before or during the cold period, or, as a control, after warming up. Before the beginning of dark adaptation, the sporangiophore was adapted by rotating under full UV light. Dark adaptation was started by a large step-down in intensity. Simultaneously rotation was stopped. In both types of experiments the angle of tilting, α , was observed. In storage experiments the onset of response is derived by extrapolating backward to $\alpha = 0$ from a region where $d\alpha/dt$ is constant. In dark adaptation experiments the “latency” is derived similarly. (The sporangiophore starts bending only

when it "sees;" i.e., when the level of adaptation has dropped to a level close to the applied intensity.) With this method (Bergman et al., 1969, sect. 15, Fig. 15-3) one can measure the kinetics of dark adaptation by working with different intensity step-downs. When lowering the intensity, the latency should increase by an amount proportional to the logarithm of the intensity ratio if the dark adaptation is an exponential function of time.

CONTROL: TROPIC RESPONSE TO VARIOUS STIMULI WITHOUT COOLING The sporangiophores were conditioned by rotating in the dark for 10 min with flow of air at room temperature, then for an additional 20 min with adapting UV light. This applies to all experiments reported in this paper. For stimuli of 0.5–2 min, and intensities equal to and up to 50 times higher than the adapting light, large tropic responses were obtained in every case. These responses varied considerably in total tilt and maximum tilting rate. The most constant feature of the responses, in spite of very different growth rates, was the time of maximum tilting rate (6–7 min).

In the hope of finding quantitative results about storage, we investigated stimulus storage with nonsaturating stimuli. For a nonsaturating stimulus the sporangiophore comes back promptly from its maximum bend and a larger stimulus increases the response. We found that a stimulus 30 sec long and 50 times the adapting light is not a saturating stimulus for sporangiophores growing at a rate of about 3 mm/hr.

CONTROL: AFTEREFFECTS OF COLD PERIODS We wish to stimulate during a cold period and observe the response after warm-up. In order to get quantitative results the appropriate control experiment is to use the same temperature regime but to stimulate just after warm-up. The control experiments without cold period are not sufficient, because the metabolism is appreciably slowed down after the cold, as will be seen.

The growth rate, v , after a cold period is plotted in Fig. 2 for a 60 min, 1°C cold period. A maximum of v is observed after warming up, followed by a period of low but varying growth rate. The maximum of v (not due to a UV light stimulus) appears 1 min after warm-up for the *fast* warm-up procedure (within 1 min from cold to room temperature). For slow warm-up (e.g., within 4 min from 5° to 16°C, then slowly to room temperature) it appears later (e.g., 6 min after the beginning of warm-up). The average growth rate in the first 10 min after warm-up divided by the average growth rate before the cold period ("recovery") is about 30% (20 min, 7°C), 50% (15 min, 5°C), and 25% (60 min, 1°C). Slow warm-up was used in connection with 5°C cold periods only. After a 5°C cold period the recovery for fast and slow warm-up (as above) did not seem to be different. Fig. 2 shows at the same time almost completely arrested growth during the 1°C cold period.

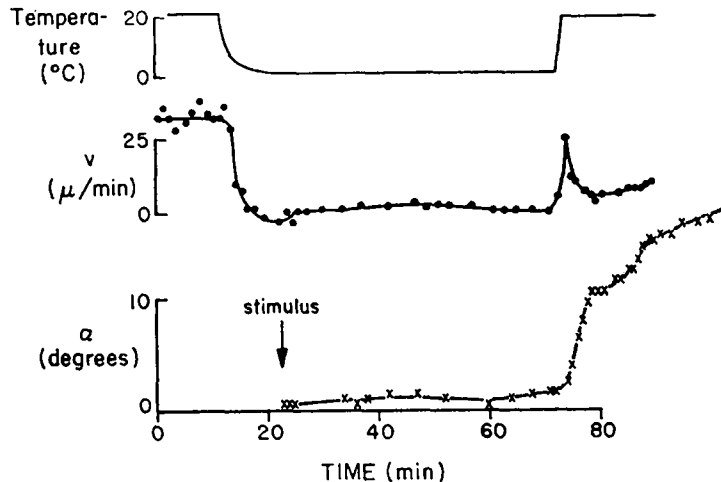

FIGURE 2. Effect of a cold period of 1°C , 1 hr. Solid circles, growth rate, v . Note almost completely arrested growth during the cold period, maximum of v 1 min after the cold period and about 25% recovery; (\times) tropic response, α , to a unilateral light stimulus (30 sec, 16 times the adapting light) given 50 min before the end of the cold. Note that bending starts 2 min after warm-up.

The bending response (maximum tilting rate and maximum tilt) of the sporangiophore to a short stimulus applied after a cold period was compared with the precold period value. After a 10 min, 11°C cold period it shows about 35% recovery. For other temperatures we have no control experiments stimulating the *same* sporangiophore before and after the cold period. However, a stimulus was given shortly (2.5 min) after warm-up from an extreme cold period (132 min, 1°C , Fig. 3, solid circles). When this response is compared with that of a control sporangiophore (Fig. 3, \times), we see that the two responses are similar with respect to general shape and time of onset. However, the response to the post-warm-up stimulus runs through its course at a much slower rate. Specifically, the time at which the bending rate is maximal occurs 7 min later than in the control.

Next, we inquire whether the dark adaptation latency after a fixed step-down is modified by a previous cold period. The latency at room temperature is about 32 min for a step-down of a factor 50. When dark adaptation is started 30 min after a cold period of 30 min at 2°C the latency is 2.5 min longer. When it is started 2.5 min after a similar cold period the latency is another 5.5 min longer. It thus seems possible that after a cold period the rate of dark adaptation is slowed down for a while.

STIMULUS STORAGE We wish to inquire whether stimuli given during a period of arrested growth result in a response after warm-up. Figs. 2 and 4-6 show examples of such experiments. No bending occurs during the cold

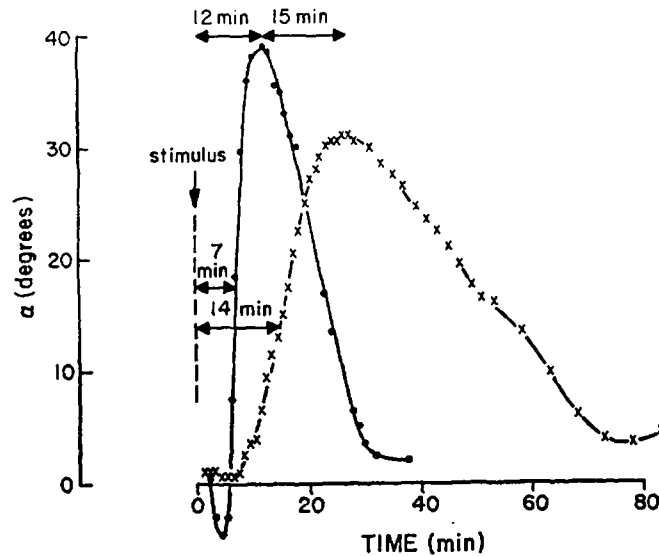

FIGURE 3. Comparison between the tropic response with and without a preceding cold period. Stimulus 30 sec long and 50 times the adapting light given at (solid circles) room temperature; (x) 2.5 min after a 132 min, 1°C cold period. Note that the sporangiophore exposed to the cold period before the stimulus runs through the response at a slower rate.

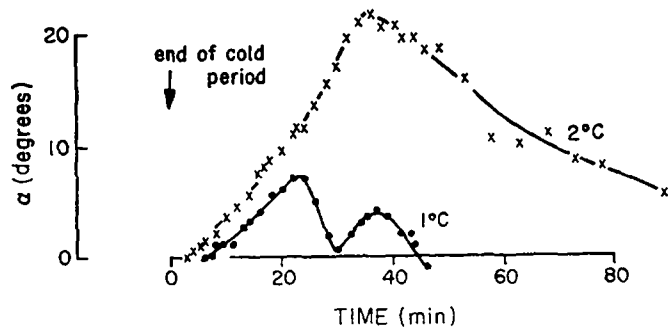

FIGURE 4. Tropic responses to a stimulus given during a cold period. Unilateral stimulus (30 sec, 50 times the adapting light) given 2 hr before the end of a 132 min period at 1°C (solid circles) and 2°C (x).

period in the cases drawn in Figs. 2 and 6, about 5° bending occurs for the cases drawn in Fig. 4. Bending after cold in the controls without stimulus was nearly zero. The bending responses produced are quite conspicuous, whether the stimuli are given at the beginning or at the end of a cold period. These experiments show clearly that there is stimulus storage for 30 min at 5°C and for 2 hr at 1–2°C.

DARK ADAPTATION DURING COLD PERIOD We were interested in investigating the course of dark adaptation at different temperatures, because

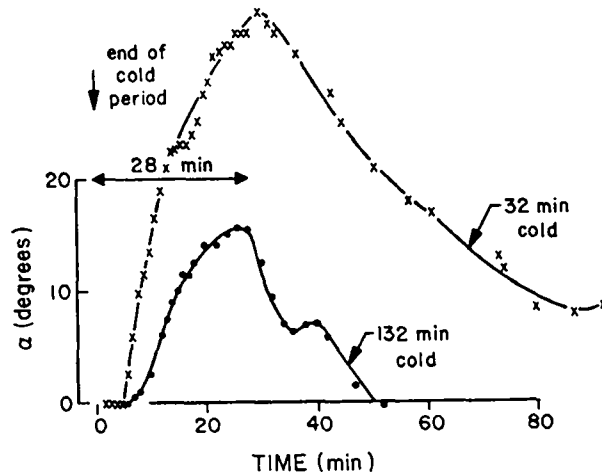

FIGURE 5. Tropic responses to a stimulus given during a cold period. Unilateral stimulus (30 sec, 50 times the adapting light) given 5 min before the end of a period of 32 min (x) and 132 min (solid circles) at 1°C. The response is smaller for the sporangiophore exposed longer to the cold. The time at which the response reaches its maximum is the same in both experiments.

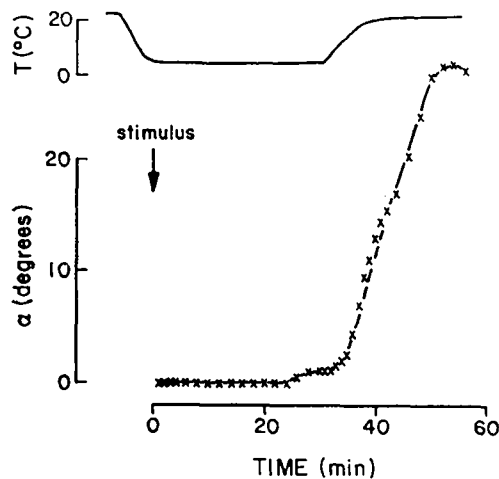

FIGURE 6. Tropic response to a stimulus given during a cold period. Unilateral stimulus (25 sec, 16 times the adapting light) given 31 min before the end of the 37 min period at 5°C.

an unusual temperature course might have given a hint of the mechanism of dark adaptation. An extreme (1°C, Fig. 8) and an intermediate (7°C, Fig. 7) temperature were chosen. Fig. 7 shows latencies of the tropic responses for a step-down by a factor of 50. The latency is increased by 15 min by a 20 min, 7°C cold period. This could suggest that for dark adaptation 20 min at 7°C are equivalent to 5 min at room temperature. However, the aftereffects of cold periods on dark adaptation weaken our conclusion. We can merely say that 20 min at 7°C are equivalent to *at least* 5 min at room temperature. On the other hand, 20 min at 7°C are certainly equivalent to less than 20 min

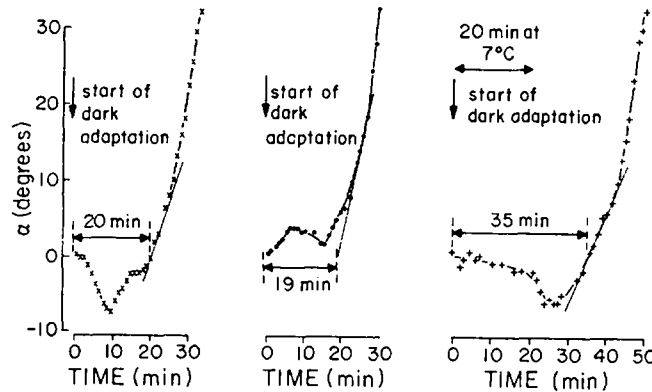

FIGURE 7. Dark adaptation with and without cold period. (x) and (solid circles), room temperature, at time zero rotation is stopped and intensity lowered from +2 to -3.5 ($5.5 \log_2$ units). (+) same light program, simultaneously a 20 min, 7°C cold period is imposed. Note an increase in latency of 15 min, indicating that dark adaptation was slowed down at 7°C .

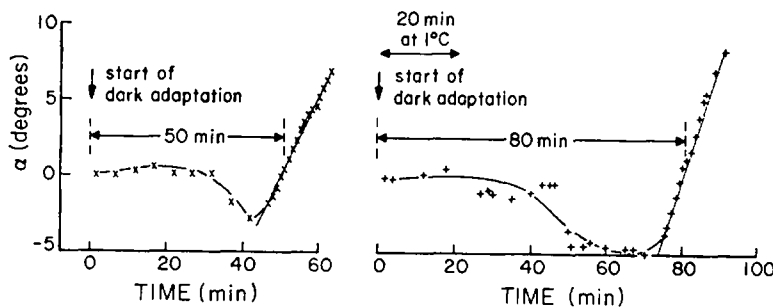

FIGURE 8. Dark adaptation with and without cold period. (x) room temperature, at time zero rotation is stopped and intensity lowered from -2 to -12 ($10 \log_2$ units, blue light); (+) same light program, simultaneously a 20 min, 1°C cold spell is imposed. Note increase in latency of 30 min.

at room temperature. Otherwise in Fig. 7 (right), dark adaptation would have been completed at 7°C and bending would have started shortly after warm-up. Fig. 8 shows the effect of a 20 min, 1°C cold period on the latency for a step-down of a factor 1000. The latency is lengthened by 30 min, 10 min more than the duration of the cold period. The most likely interpretation of this result is that during the cold period dark adaptation was fully arrested and that the excess delay is due to a post-warm-up slowdown of dark adaptation similar to that described in the section on aftereffects.

DISCUSSION

The present investigations show:

1. The previous results (Ebrey and Clayton, 1969) on post-warm-up growth responses to light stimuli received during a cold period appeared

unconvincing to us because we found that even without a stimulus there occur post-warm-up transient changes in growth rate which we could not distinguish from light-growth responses.

2. When however, *unilateral UV* light is used as a tropic stimulus very clear evidence is obtained for stimulus perception and storage at 2°C for at least 2 hr. Presumably the stimulus is stored in the form of some chemical intermediate.

A previous hint that long-lived and transportable intermediates are involved in the chain leading from the light stimulus to the growth response had previously been obtained in experiments of Delbrück and Varju (1961). These authors had stimulated very narrow transverse sections of the growing zones of sporangiophores with light. Stimuli applied in the top 0.5 mm did not give reactions there but some distance lower down, and with a latency a few minutes longer than if the stimulus had been directly applied in the reacting part. This finding suggested that some intermediate persists for several minutes and is transported from the "sensitive" to a "reactive" zone. We do not know whether these intermediates are the same as the intermediates stored during cold periods.

3. Dark adaptation slows down during a cold period but its kinetics remain an unresolved problem because a cold period has prolonged after-effects. These aftereffects will have to be analyzed or eliminated before the original question can be answered.

4. A defect of the present investigation lies in the fact that we did not succeed in bringing specimens back to a prompt resumption of their normal behavior after warm-up. The average growth rates obtained during the first hour vary between 0.2 and 0.5 of normal. It is possible that these vagaries depend on the transients in turgor occurring during the warm-up step. It is possible that closer attention to humidity at the growing zone and to temperature at the base may lead to full recovery of sporangiophores.

This work was supported in part by grant No. GB-8527 of the National Science Foundation and by a grant from the Stiftung Volkswagenwerk. Dr. Petzuch held a NATO postdoctoral fellowship.

Received for publication 6 March 1970.

REFERENCES

- BERGMAN, K., P. V. BURKE, E. CERDÁ-OLMEDO, C. N. DAVID, M. DELBRÜCK, K. W. FOSTER, E. W. GOODELL, M. HEISENBERG, G. MEISSNER, M. ZALOKAR, D. S. DENNISON, and W. SHROPSHIRE, JR. 1969. Phycomyces. *Bacteriol. Rev.* 33:99.
- DELBRÜCK, M., and W. REICHARDT. 1956. System analysis for the light growth reaction in Phycomyces. In *Cellular Mechanisms in Differentiation and Growth*. D. Rudnick, editor. Princeton University Press, Princeton, N.J. 3.
- DELBRÜCK, M., and D. VARJU. 1961. Photoreactions in Phycomyces. Responses to the stimulation of narrow test areas with ultraviolet light. *J. Gen. Physiol.* 44:1177.
- EBREY, T. G., and R. K. CLAYTON. 1969. Phycomyces: Stimulus storage in light-initiated reactions. *Science (Washington)*. 164:427.