



# Ghost Imaging without Discord

Jeffrey H. Shapiro, Dheera Venkatraman & Franco N. C. Wong

Research Laboratory of Electronics, Massachusetts Institute of Technology 77 Massachusetts Avenue, Cambridge, Massachusetts 02139, USA.

SUBJECT AREAS:  
QUANTUM MECHANICS  
QUANTUM INFORMATION  
QUANTUM METROLOGY  
QUANTUM OPTICS

**Ragy and Adesso argue that quantum discord is involved in the formation of a pseudothermal ghost image. We show that quantum discord plays no role in spatial light modulator ghost imaging, i.e., ghost-image formation based on structured illumination realized with laser light that has undergone spatial light modulation by the output from a pseudorandom number generator. Our analysis thus casts doubt on the degree to which quantum discord is necessary for ghost imaging.**

Received  
11 April 2013

Accepted  
1 May 2013

Published  
15 May 2013

Correspondence and  
requests for materials  
should be addressed to  
J.H.S. (jhs@mit.edu)

Ghost images are formed from the outputs of two photodetectors: a high spatial-resolution detector that is illuminated by light which has not interacted with the object to be imaged; and a bucket detector with no spatial resolution that is illuminated by light which has interacted with the object. Neither detector's output suffices to produce an image, but an image emerges by cross correlating their outputs from a sequence of correlated irradiance patterns<sup>1–4</sup>. The initial demonstration of ghost imaging used the entangled signal and idler obtained from spontaneous parametric downconversion<sup>1</sup>, hence it was thought that ghost-image formation was a fundamentally quantum effect. A controversy soon arose, however, when theory<sup>5–8</sup> and experiment<sup>9,10</sup> showed that ghost images could be produced using the pseudothermal light obtained from passing a laser beam through a rotating ground-glass diffuser. One side in this debate argued that lensless pseudothermal ghost imaging could only be explained by nonlocal two-photon interference<sup>11,12</sup>, while the other argued that an equivalent quantitative description could be developed from semiclassical photodetection theory, in which the light is treated classically<sup>13,14</sup>. Later, it was demonstrated these two disparate interpretations could coexist<sup>15</sup>, although the dispute continued thereafter<sup>16,17</sup>.

The crux of the preceding argument about the physics of pseudothermal ghost imaging can be distilled to the following: Suppose the imaging-forming system is comprised of: (1) an optical source whose output quantum state has a positive Glauber  $P$ -representation; (2) linear optics, such as beam splitters, free-space propagation, and passage through an object transparency; and (3) conventional photodetection, specifically direct detection, homodyne detection, or heterodyne detection. Quantum optics has long held that the measurement statistics produced by such an arrangement are identical when computed from quantum photodetection theory and from semiclassical photodetection theory<sup>18,19</sup>. Recently, however, a new slant on the quantum versus classical debate for pseudothermal ghost imaging emerged, when Ragy and Adesso showed<sup>20</sup> that quantum correlation—measured by quantum discord<sup>21–24</sup>—plays a significant role in Gaussian-state ghost imaging. In particular, their calculations revealed that the signal-to-noise ratios of both lensed and lensless ghost imaging performed with classically-correlated Gaussian state light—the standard source model for pseudothermal ghost imaging—shared parametric dependence that mimicked the corresponding behavior of the total correlations, i.e., the classical correlations plus the quantum discord, even though this source is unentangled and, indeed, has a positive Glauber  $P$ -representation.

The purpose of the present paper is not to refute any of the calculations reported by Ragy and Adesso, but instead to present a rather different view of classical-state ghost imaging, specifically a Gaussian pure-state treatment in which quantum discord cannot enter. Consequently, although one may rightly argue about the fundamental importance of quantum discord in Gaussian mixed-state ghost imaging, no such role can possibly exist for all forms of ghost imaging.

## Results

Consider the spatial light modulator (SLM) form of lensless ghost imaging shown in Fig. 1<sup>25</sup> and implemented by Venkatraman *et al.* in Ref. 26. Here a pseudorandom number generator (PRNG) applies a sequence of phase maps to the  $K \times K$  pixels of an SLM, one map for each of  $M$  normally-incident plane-wave laser pulses that illuminate the SLM. The modulated light is divided into signal and reference beams by a 50–50 beam splitter, with one propagating over an  $L$ -m-long free-space path to a charged-coupled device (CCD) detector and the second propagating over an  $L$ -m-long free-space path to an object transparency. A bucket detector then collects the light

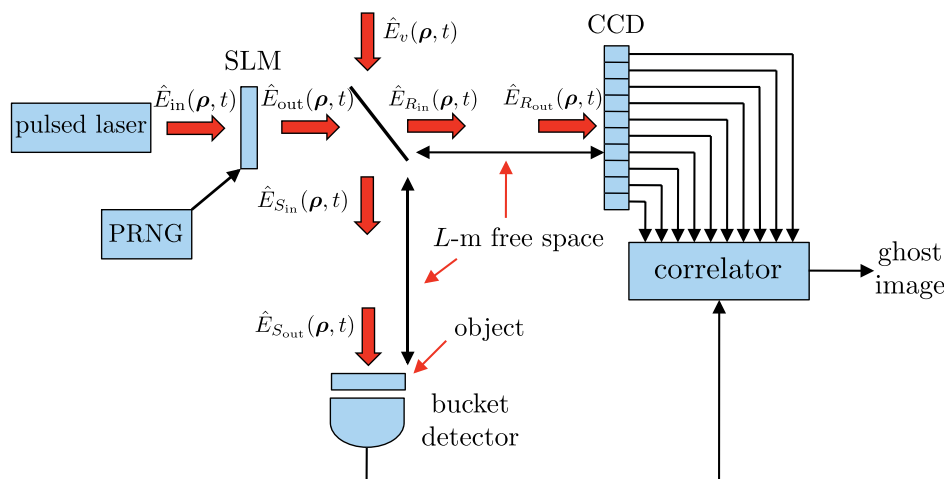

**Figure 1** | Setup for spatial light modulator (SLM) lensless ghost imaging using a pseudorandom number generator (PRNG), a charge-coupled device (CCD) camera, and a bucket detector.

transmitted through that transparency, and the ghost image is formed by cross correlating the sequence of bucket detector outputs with those from the CCD. In Ref. 25, the entire collection of pseudorandom phases— $M$  phase maps each comprised of  $K \times K$  pixel phases—were taken to be independent, identically distributed, random variables that were uniformly distributed on  $[0, 2\pi]$ , and an expression was presented for the covariance function of the zero-mean field that results after far-field diffraction. Then, invoking the central limit theorem to justify the assumption that this far-field illumination is a Gaussian random process, SLM ghost imaging was argued to be equivalent to pseudothermal ghost imaging. The analysis in Ref. 25 employed semiclassical photodetection theory, because, as noted earlier, it relies on laser light that has undergone linear-optics transformations—at the SLM and in far-field diffraction—followed by conventional direct detection. It is essential to the present purpose, however, to recast that analysis in a fully quantum-mechanical form, and, moreover, to pay special attention to the pseudorandom numbers used to drive the SLM through its sequence of phase maps.

In lieu of the classical SLM input and output fields considered in Ref. 25, let  $\hat{E}_{in}(\rho, t)$  be the positive-frequency,  $\sqrt{\text{photons/m}^2\text{s}}$ -units field operator that illuminates the SLM in Fig. 1 at transverse position  $\rho = (x, y)$  and time  $t$ , and let  $\hat{E}_{out}(\rho, t)$  be the field operator that results at the SLM's output. The former will be taken to be in the coherent state  $|E_{in}(\rho, t)\rangle$ , with eigenfunction

$$E_{in}(\rho, t) = \sum_{m=0}^{M-1} \sqrt{\frac{N_T}{M}} p(t - mT_r) e^{-i\omega_0 t}, \quad (1)$$

where:  $\omega_0$  is the laser's center frequency;  $p(t)$  is a baseband pulse that is time-limited to  $0 \leq t \leq T_p$  and normalized to satisfy  $\int dt |p(t)|^2 = 1$ ;  $T_r > T_p$  is the pulse-repetition interval; and  $N_T$  is the state's total average photon number. We will assume that the SLM has square pixels of size  $d \times d$ , 100% fill factor, and overall dimensions  $D \times D$ , with the  $ij$ th pixel occupying the region  $\mathcal{A}_{ij}$  in the  $z = 0$  plane, where the SLM is located. Assuming a lossless SLM, we then have that  $\hat{E}_{out}(\rho, t) = \hat{E}_{in}(\rho, t) e^{i\phi_{ij}(t)}$ , for  $\rho \in \mathcal{A}_{ij}$  and  $1 \leq i, j \leq K$ , where  $\phi_{ij}(t) =$

$\phi_{ijm}$  for  $mT_r \leq t \leq mT_r + T_p$ ,  $0 \leq m \leq M - 1$  and zero otherwise, with  $\{\phi_{ijm}: 1 \leq i, j \leq K\}$  being the  $m$ th pseudorandom phase map. So, conditioned on knowledge of the pixel phases,  $\hat{E}_{out}(\rho, t)$  will be in the coherent state  $|E_{out}(\rho, t)\rangle$  with eigenfunction

$$E_{out}(\rho, t) = \sum_{m=0}^{M-1} \sqrt{\frac{N_T}{M}} e^{i\phi_{ijm}} p(t - mT_r) e^{-i\omega_0 t}, \quad (2)$$

for  $\rho \in \mathcal{A}_{ij}$  and  $1 \leq i, j \leq K$ . The quantum form of the Huygens-Fresnel principle<sup>14,15</sup>—together with the assumptions that the  $\{\phi_{ijm}\}$  are independent, identically-distributed random variables which are uniformly distributed on  $[0, 2\pi]$  and  $K$  is an odd integer—then reproduces the semiclassical mean and covariance from Ref. 25 for far-field diffraction of the quantum signal and reference field operators,

$$\hat{E}_{S_{in}}(\rho, t) \equiv \frac{\hat{E}_{out}(\rho, t) + \hat{E}_v(\rho, t)}{\sqrt{2}} \quad (3)$$

and

$$\hat{E}_{R_{in}}(\rho, t) \equiv \frac{\hat{E}_{out}(\rho, t) - \hat{E}_v(\rho, t)}{\sqrt{2}} \quad (4)$$

that emerge from the 50–50 beam splitter in Fig. 1, where  $\hat{E}_v(\rho, t)$  is the vacuum-state field operator entering the beam splitter's free input port. Thus, coherent-state illumination of the SLM plus the statistics just assumed for the pixel phases leads to pseudothermal, i.e., mixed Gaussian-state, behavior for the joint state of the signal and reference field operators impinging on the transmission mask and the CCD in Fig. 1. Hence the discord analysis from Ref. 20 is directly applicable. But a pseudorandom number generator does *not* produce true randomness, and this has a very significant consequence with respect to the role of discord in SLM ghost imaging.

Pseudorandom numbers are produced by supplying a deterministic seed number to a deterministic algorithm. Consequently, it is entirely fair for us to have complete knowledge of the  $\{\phi_{ijm}\}$  entering into the preceding description of SLM-based ghost imaging. It immediately follows that the joint state of the signal and reference beams

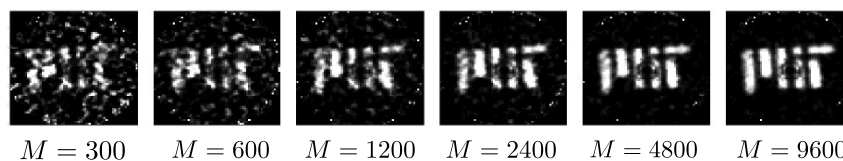

**Figure 2** | Spatial light modulator ghost images of the MIT logo versus  $M$ , the number of illumination patterns.

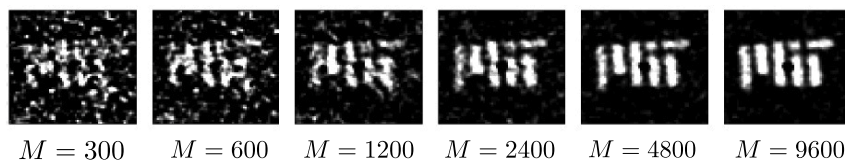

**Figure 3** | Computational ghost images of the MIT logo versus  $M$ , the number of illumination patterns.

that illuminate the object transparency and the CCD detector is the coherent-state product,  $|E_{S_{\text{out}}}(\rho', t)\rangle|E_{R_{\text{out}}}(\rho', t)\rangle$ , with identical eigenfunctions given by

$$E_{J_{\text{out}}}(\rho', t) = \int d\rho \frac{E_{\text{out}}(\rho, t - L/c)}{\sqrt{2}} \frac{e^{ik|\rho' - \rho|^2/2L}}{i\lambda L}, \quad (5)$$

for  $J = S, R$ , where  $k = \omega_0/c$  and  $\lambda = 2\pi c/\omega_0$  are the wave number and wavelength associated with the center frequency  $\omega_0$ , and quasimono-chromatic, paraxial propagation over an  $L$ -m-long free-space path has been presumed. Thus the SLM ghost image, found by cross correlating the outputs from the CCD and the bucket detector, arises from Gaussian pure-state illumination of the transparency and the CCD, a situation in which there is no quantum discord because quantum discord is a measure of entanglement in the pure-state case. In short, quantum discord is *not* essential to forming a ghost image. Indeed, in SLM lensless ghost imaging it plays no role whatsoever.

## Discussion

In Ref. 15 we asserted that “a ghost-imaging configuration is ‘classical’ if its measurement statistics are correctly described by the use of semiclassical photodetection theory, and that the configuration is ‘quantum’ if a correct description of its measurement statistics *requires*

the use of quantum photodetection theory.” Thus Refs. 13, 14 concluded that pseudothermal, i.e., Gaussian mixed-state, ghost imaging was classical, because its statistical descriptions in the semiclassical and quantum theories of photodetection were identical. Ragy and Adesso’s discord analysis<sup>20</sup>, however, suggests that there *is* a fundamentally quantum aspect to pseudothermal ghost imaging, whereas we have argued in the preceding section that such is certainly *not* the case for SLM ghost imaging. Our argument relied on the intrinsically deterministic nature of the pseudorandom phases applied to the spatial light modulator in the Fig. 1 setup, as opposed to the random nature of laser light propagation through a rotating ground-glass diffuser. But how random is laser light propagation through that diffuser? Cannot it be characterized by a highly complicated but nonetheless deterministic spatially-varying refractive index? If such is the case, then conventional pseudothermal ghost imaging’s statistical characterization of its far-field irradiance patterns merely represents our inability to specify that refractive-index distribution and to do the multiple-scattering analysis of light propagation through it. Carried to its logical conclusion, this train of thought would conclude that pseudothermal ghost-image formation, like SLM ghost imaging, relies on product coherent-state illumination and hence is discord free. We will not argue that point, largely because it entails the question of whether true randomness exists in classical electromagnetism. Instead, we devote

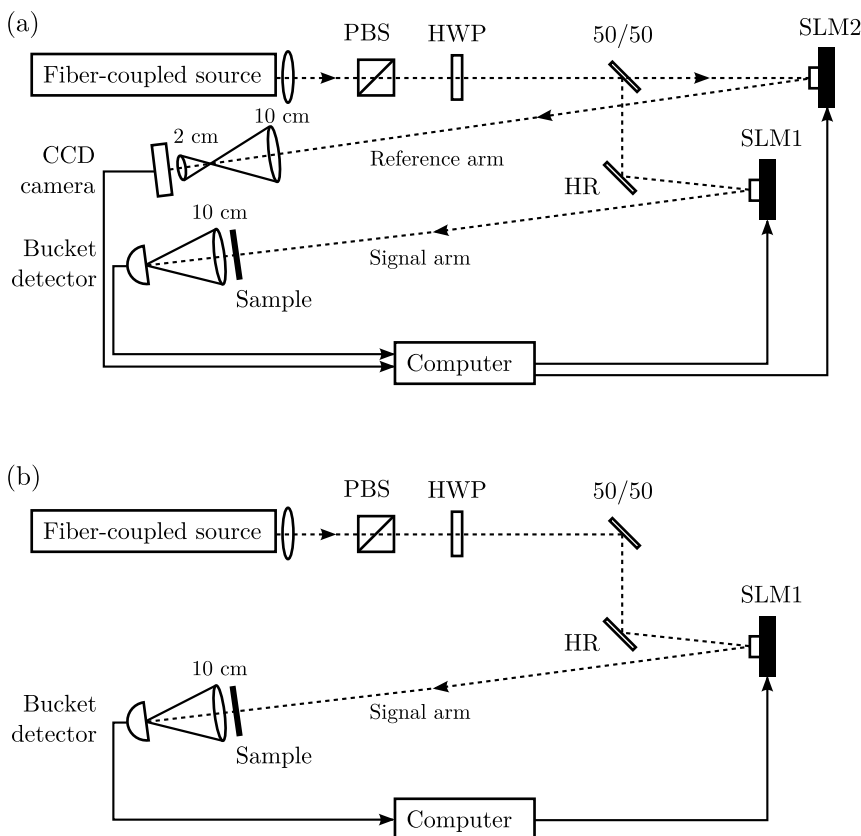

**Figure 4** | Setup used to collect the ghost images in (a) Fig. 2 and (b) Fig. 3. PBS: polarizing beam splitter. HWP: half-wave plate. SLM: spatial light modulator. HR: high reflector.



the rest of this section to underscoring the deterministic nature of SLM ghost imaging.

Figure 2 shows SLM ghost images of the MIT logo formed from a setup like that shown in Fig. 1 with  $M$  values ranging from 300 to 9600; see Methods for the details. That this is truly a deterministic setup can be demonstrated as follows. Because the SLM in Fig. 1 is driven by a deterministic sequence of phase maps, there is no need to propagate a reference beam: free-space diffraction of the eigenfunction  $E_{R_{in}}(\rho, t)$  can be computed by evaluating the diffraction integral in Eq. (5) and cross correlating the calculated  $|E_{R_{out}}(\rho, t)|^2$  with the output from the bucket detector. What results is a computational ghost imager, first described in Ref. 25 and subsequently demonstrated in Ref. 27. In particular, for the MIT logo whose SLM ghost images are shown in Fig. 2, the setup from Ref. 26 yielded the corresponding computational ghost images shown in Fig. 3. Here there is absolutely no possibility for quantum discord to play any role, because there is only one optical beam used to form the ghost image. Note that prior to the appearance of Ref. 25, computational ghost imaging was already known in the signal processing community as the structured illumination version of the single-pixel camera<sup>28</sup>.

In conclusion, the importance of quantum discord in quantum communication and computation is being widely studied, and Ragy and Adesso<sup>20</sup> have shown how it may be used to understand pseudo-thermal ghost imaging. We, however, have shown that discord is not universally at work in ghost imaging.

## Methods

Figures 4(a) and (b) show the experimental setups used to obtain the SLM-based ghost images shown in Figs. 2 and 3, respectively. For the SLM ghost images of Fig. 2, a 10-mW, 795-nm laser source was divided by a 50–50 beam splitter into signal and reference beams, each of which was focused onto a Boulder Nonlinear Systems SLM unit with  $512 \times 512$  pixels, each  $15 \times 15 \mu\text{m}$  in size with individually addressable phases. We focused each beam at the SLM plane with a beam waist  $w_0 \approx 200 \mu\text{m}$ . A computer was used to generate a  $128 \times 128$  array of pseudorandom phases that we applied synchronously to the central  $128 \times 128$  pixels of SLM1 and SLM2 at a frame rate of 2.5 Hz, giving rise to phase-insensitive cross correlations. The imaging object was a binary transmission mask bearing the MIT logo printed onto a transparency slide that we placed in the signal arm at a distance  $L = 80 \text{ cm}$  from SLM1. A 10-cm focal length lens was used to focus all the transmitted light onto a single-pixel (bucket) silicon detector (Thorlabs PDA55). To obtain the SLM ghost images of Fig. 2, we placed in the reference arm a shutterless Basler Pilot CCD camera with  $1600 \times 1200$  pixels, each measuring  $7.4 \times 7.4 \mu\text{m}$  with 12-bit dynamic range. The CCD was placed at the same distance  $L$  from SLM2, as shown in Fig. 4(a). The central  $1200 \times 1200$  portion of the CCD pixels were used for imaging and re-binned into  $300 \times 300$  superpixels, each consisting of  $4 \times 4$  pixels. By computing the covariances between each of the CCD superpixels and the bucket detector output over  $M$  trials, we obtained the SLM ghost images in Fig. 2 for different  $M$ . We should note that the setup of Fig. 4(a) was also used to demonstrate phase-sensitive classical ghost imaging in Ref. 26 by programming SLM2 with the exact SLM1-complementary pattern to generate phase-sensitive cross correlations between the signal and reference beams.

To obtain the computational ghost images of Fig. 3 we used the setup of Fig. 4(b) whose signal arm is identical to the setup in Fig. 4(a) but without the reference beam and all the optical components in the reference arm, including SLM2. Instead, we used Gaussian beam propagation theory in the far field<sup>25</sup> to compute the fields deterministically from our knowledge of the computer-generated pseudorandom phase patterns that were applied to SLM1. By computing the covariances between the single-pixel detector output and the computed far-field irradiance patterns over  $M$  trials we obtained the computational ghost images in Fig. 3 for different  $M$  using only a single bucket detector.

- Pittman, T. B., Shih, Y. H., Strekalov, D. V. & Sergienko, A. V. Optical imaging by means of two-photon quantum entanglement. *Phys. Rev. A* **52**, R3429–R3432 (1995).
- Bennink, R. S., Bentley, S. J. & Boyd, R. W. “Two-photon” coincidence imaging with a classical source. *Phys. Rev. Lett.* **89**, 113601 (2002).
- Gatti, A., Brambilla, E. & Lugiato, L. A. Entangled imaging and wave-particle duality: from the microscopic to the macroscopic realm. *Phys. Rev. Lett.* **90**, 133603 (2003).
- Bennink, R. S., Bentley, S. J., Boyd, R. W. & Howell, J. C. Quantum and classical coincidence imaging. *Phys. Rev. Lett.* **92**, 033601 (2004).

- Gatti, A., Brambilla, E., Bache, M. & Lugiato, L. A. Correlated imaging, quantum and classical. *Phys. Rev. A* **70**, 013802 (2004).
- Gatti, A., Brambilla, E., Bache, M. & Lugiato, L. A. Ghost imaging with thermal light: comparing entanglement and classical correlation. *Phys. Rev. Lett.* **93**, 093602 (2004).
- Cai, Y. & Zhu, S.-Y. Ghost imaging with incoherent and partially coherent light radiation. *Phys. Rev. E* **71**, 056607 (2005).
- Cai, Y. & Zhu, S.-Y. Ghost interference with partially coherent light radiation. *Opt. Lett.* **29**, 2716–2718 (2004).
- Valencia, A., Scarcelli, G., D’Angelo, M. & Shih, Y. Two-photon imaging with thermal light. *Phys. Rev. Lett.* **94**, 063601 (2005).
- Ferri, F., Magatti, D., Gatti, A., Bache, M., Brambilla, E. & Lugiato, L. A. High-resolution ghost image and ghost diffraction experiments with thermal light. *Phys. Rev. Lett.* **94**, 183602 (2005).
- Scarcelli, G., Berardi, V. & Shih, Y. Can two-photon correlation of chaotic light be considered as correlation of intensity fluctuations? *Phys. Rev. Lett.* **96**, 063602 (2006).
- Meyers, R., Deacon, K. S. & Shih, Y. Ghost-imaging experiment by measuring reflected photons. *Phys. Rev. A* **77**, 041801(R) (2008).
- Erkmen, B. I. & Shapiro, J. H. Unified theory of ghost imaging with Gaussian-state light. *Phys. Rev. A* **77**, 043809 (2008).
- Erkmen, B. I. & Shapiro, J. H. Ghost imaging: from quantum to classical to computational. *Adv. Opt. Photon.* **2**, 405–450 (2011).
- Shapiro, J. H. & Boyd, R. W. The physics of ghost imaging. *Quantum Inf. Process.* **11**, 949–993 (2012).
- Shih, Y. The physics of ghost imaging: nonlocal interference or local intensity fluctuation correlation? *Quantum Inf. Process.* **11**, 995–1001 (2012).
- Shapiro, J. H. & Boyd, R. W. Response to “The physics of ghost imaging—nonlocal interference or local intensity fluctuation correlation?” *Quantum Inf. Process.* **11**, 1003–1011 (2012).
- Yuen, H. P. & Shapiro, J. H. Optical communication with two-photon coherent states—Part III: quantum measurements realizable with photoemissive detectors. *IEEE Trans. Inform. Theory* **26**, 78–92 (1980).
- Shapiro, J. H. The quantum theory of optical communications. *IEEE J. Sel. Top. Quantum Electron.* **15**, 1547–1569 (2009).
- Ragy, S. & Adesso, G. Nature of light correlations in ghost imaging. *Sci. Rep.* **2**, 651 (2012).
- Ollivier, H. & Zurek, W. H. Quantum discord: a measure of quantumness of correlation. *Phys. Rev. Lett.* **88**, 017901 (2002).
- Giorda, P. & Paris, M. G. A. Gaussian quantum discord. *Phys. Rev. Lett.* **105**, 020503 (2010).
- Adesso, G. & Datta, A. Quantum versus classical correlation in Gaussian states. *Phys. Rev. Lett.* **105**, 030501 (2010).
- Blandino, R., Genoni, M. G., Etesse, J., Barbieri, M., Paris, M. G. A., Grangier, P. & Tualle-Brouiri, R. Homodyne estimation of Gaussian quantum discord. *Phys. Rev. Lett.* **109**, 180402 (2012).
- Shapiro, J. H. Computational ghost imaging. *Phys. Rev. A* **78**, 061802(R) (2008).
- Venkatraman, D., Hardy, N. D., Wong, F. N. C. & Shapiro, J. H. Classical far-field phase-sensitive ghost imaging. *Opt. Lett.* **36**, 3684–3686 (2011).
- Bromberg, Y., Katz, O. & Silberberg, Y. Ghost imaging with a single detector. *Phys. Rev. A* **79**, 053840 (2009).
- Duarte, M. F., Davenport, M. A., Takhar, D., Laska, J. N., Sun, T., Kelly, K. F. & Baraniuk, R. G. Single-pixel imaging via compressive sampling. *IEEE Signal Proc. Mag.* **25**, 83–91 (March 2008).

## Acknowledgments

This work was supported by the DARPA InPho program through the U.S. Army Research Office award W911NF-10-1-0404.

## Author contributions

J.H.S. did the theory. D.V. and F.N.C.W. built the ghost imaging setup, collected the data, and obtained the images shown in Figs. 2 and 3. All authors contributed to discussions and writing the paper.

## Additional information

**Competing financial interests:** The authors declare no competing financial interests.

**License:** This work is licensed under a Creative Commons Attribution-NonCommercial-NoDerivs 3.0 Unported License. To view a copy of this license, visit <http://creativecommons.org/licenses/by-nc-nd/3.0/>

**How to cite this article:** Shapiro, J.H., Venkatraman, D. & Wong, F.N.C. Ghost Imaging without Discord. *Sci. Rep.* **3**, 1849; DOI:10.1038/srep01849 (2013).