



ELSEVIER

Contents lists available at ScienceDirect

Data in Brief

journal homepage: www.elsevier.com/locate/dib

Data Article

Life cycle inventory data for power production from sugarcane press-mud

Nestor Sanchez^a, Ruth Ruiz^b, Anne Rödl^c, Martha Cobo^{a,*}^aEnergy, Materials, and Environmental Laboratory, Department of Chemical and Biochemical Processes, Universidad de La Sabana, Campus Universitario Puente del Común, Km. 7 Autopista Norte, Bogotá, Colombia^bAgroindustrial Processes Group, Faculty of Engineering, Universidad de La Sabana, Campus Universitario Puente Del Común, Km. 7 Autopista Norte, Bogota, Colombia^cHamburg University of Technology (TUHH), Institute of Environmental Technology and Energy Economics (IUE), Eissendorfer Straße 40, D-21073, Hamburg, Germany

ARTICLE INFO

Article history:

Received 5 May 2021

Revised 20 May 2021

Accepted 31 May 2021

Available online 3 June 2021

Dataset link: [Dataset for the production of power from sugarcane press-mud \(Original data\)](#)

Keywords:

Bioethanol

Biomethane

Catalyst

Fuel cells

Hydrogen

Life Cycle Assessment

ABSTRACT

This data article is associated with the research article “Technical and environmental analysis on the power production from residual biomass using hydrogen as energy vector”. This paper shows the procedure to calculate the Life Cycle Inventory (LCI) of the foreground system to perform the Life Cycle Assessment (LCA) of the power production from sugarcane press-mud. Said process encompasses four main stages: i) bioethanol production; ii) bioethanol purification; iii) syngas production and purification; and iv) power production. Additionally, other processes such as biomethane production and manufacturing of catalyst were included. Foreground data related to bioethanol production was gathered from experimental procedures at lab-scale. While foreground data, concerning the other processes such as bioethanol purification, syngas production and purification, power production, and biomethane production, was built by using material and energy flows obtained from Aspen Plus®. Lastly, LCI of the catalyst manufacturing was built based on literature review and the approach stated by Ecoinvent. All the inventories are meaningful to carry out future environmental assessments involving sustainable energy systems based on bioethanol, biomethane, or hydrogen.

DOI of original article: [10.1016/j.renene.2021.04.145](https://doi.org/10.1016/j.renene.2021.04.145)

* Corresponding author(s): Martha Cobo

E-mail address: martha.cobo@unisabana.edu.co (M. Cobo).<https://doi.org/10.1016/j.dib.2021.107194>2352-3409/© 2021 The Authors. Published by Elsevier Inc. This is an open access article under the CC BY-NC-ND license (<http://creativecommons.org/licenses/by-nc-nd/4.0/>)

© 2021 The Authors. Published by Elsevier Inc.
 This is an open access article under the CC BY-NC-ND
 license (<http://creativecommons.org/licenses/by-nc-nd/4.0/>)

Specifications Table

Subject	Renewable Energy, Sustainability, and the Environment
Specific subject area	Life Cycle Assessment
Type of data	Table Figure
How data were acquired	Data of bioethanol production were acquired by experimental procedure at lab-scale and subsequent material and energy balances. Data of power production from bioethanol and biomethane were taken from Aspen based on material and energy balances. Data of catalyst manufacturing were taken from scientific literature, databases, material, and energy balances. Transportation distances were taken by means of Google-maps.
Data format	Raw and processed
Parameters for data collection	Samples of sugarcane press-mud were processed to produce bioethanol at a lab-scale. Material and energy balances were performed based on that experimental data. Bioethanol composition at lab-scale was used as the main input in an Aspen flowsheet to estimate the Material and energy balances of power production. Key data to gather primary data was retrieved from scientific papers and databases.
Description of data collection	Primary data concerning bioethanol production were obtained from experimental work at lab-scale conditions. Other data were obtained from Aspen simulations, databases, scientific reports, academic theses, and patents.
Data source location	Institution: Universidad de La Sabana City/Town/Region: Chia, Cundinamarca Country: Colombia
Data accessibility	Raw data Repository name: Mendeley Data Data identification number: doi: 10.17632/5nhfjhh778.2 Direct URL to the data: http://dx.doi.org/10.17632/5nhfjhh778.2 Processed data With the article
Related research article	N. Sanchez, R. Ruiz, A. Rödl, M. Cobo, Technical and environmental analysis on the power production from residual biomass using hydrogen as energy vector, <i>Renewable Energy</i> 175 (2021) 825-839.

Value of the Data

- The data shown in this contribution allow to strengthen the Life Cycle Assessment depicts in the main article.
- The data shown in this document could be used by anyone who wants to assess the environmental performance of energy systems based on bioethanol, hydrogen, and power from fuel cells.
- The data could be employed to model and simulate similar processes.

1. Data Description

This article shows the life cycle inventory (LCI) of the foreground system needed to perform a life cycle assessment (LCA) of power production from sugarcane press-mud. These data give transparency to the main results shown in the reference article [1]. LCI was gathered from experimental data at lab-scale, simulation from Aspen Plus V9 (Aspentech, Bedford, USA), Ecoinvent database V3.4, scientific and academic reports, and websites. Fig. 1 shows the foreground

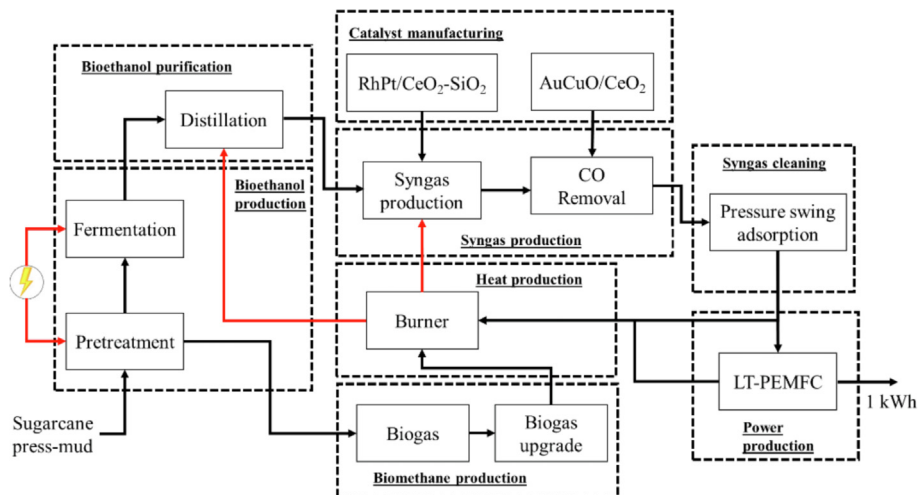

Fig. 1. Foreground system to produce power from sugarcane press-mud.

Table 1

Data source of the processes required to produce power from sugarcane press-mud.

Process	Data source	Reference
Bioethanol production	Lab-scale experiments	[2,3]
Bioethanol purification	Scientific papers, Aspen plus simulation data	[4]
H ₂ production	Aspen plus simulation, lab-scale data	[2,5]
H ₂ purification	Scientific papers, lab-scale data	[6]
Biomethane production	Aspen plus simulation data, scientific papers	[7]
Colombian power grid	Colombian Databases, Ecoinvent	[8]
Catalyst manufacturing	Scientific papers, lab-scale data, Ecoinvent assumptions	[9–14]

system for producing power from sugarcane press-mud, while Table 1 shows the data sources employed to build the complete LCI. Mostly of the data information were retrieved from Aspen Plus and the main simulation flowsheets are depicted in the main manuscript [1]. Tables 2 and 3 describe the operating conditions of main processes highlighting that three scenarios were addressed under three different separation processes units: i) flash distillation (scenario 1); ii) mash column (scenario 2); and iii) mash column followed by a rectification unit (scenario 3).

Figs. 2–4 validate the simulation results by comparing them with both experimental (i.e., H₂ composition) and commercial (i.e., polarization curves of fuel cell) data. Table 4 shows both the energy consumption and the cooling water demand of main energy blocks, such as pumps, compressors, heat exchangers, reactors, and condensers. Figs. 5 and 6 depict the Aspen flowsheets to produce biomethane and power in a Rankine cycle, respectively. Table 5 describes the operating conditions to produce biomethane from the solid fraction of sugarcane press-mud. Tables 6 and 7 show the power distribution in the 32 departments of Colombia. Fig. 7 portrays the block flow diagram to synthesize RhPt/CeO₂-SiO₂ and Au-CuO/CeO₂ under laboratory conditions. Whilst Fig. 8 illustrates the block flow diagram to manufacture the main precursors to produce the above catalysts at industrial level. Table 8 describes the Ecoinvent assumptions to build the LCI of chemicals that are not included within Ecoinvent databases. Tables 9–26 summarize the LCI of the foreground systems detailed in Fig. 1.

Aside from the data shown in this document, the raw data to calculate the inventory data for both the power production from sugarcane press-mud and the synthesis of catalysts are shown in the repository in Mendeley [15]. On the one hand, the dataset associated with the power production from sugarcane press-mud included: (i) mass and energy balances from Aspen Plus

Table 2

Aspen subroutines description for bioethanol purification processes.

Aspen subroutine	Scenario 1 (Flash distillation)	Scenario 2 (Mash column)	Scenario 3 (Mash column + rectification)
P-101	$P_{out} = 1 \text{ atm}$ Efficiency: 75%	$P_{out} = 1 \text{ atm}$ Efficiency: 75%	$P_{out} = 1 \text{ atm}$ Efficiency: 75%
E-100	$T_{out} = 93 \text{ }^\circ\text{C}$ $\Delta P = 0 \text{ atm}$	$\Delta P = 0 \text{ atm}$ $\Delta T_{min} = 10 \text{ }^\circ\text{C}$	$\Delta P = 0 \text{ atm}$ $\Delta T_{min} = 10 \text{ }^\circ\text{C}$
T-101	Duty: 0 MJ/h $\Delta P = 0 \text{ atm}$	Condenser: none Reboiler: none Stages: 24 Feed tray: 1 (on-stage) Column pressure: 0.81 atm $\Delta P = 0.015 \text{ atm/tray}$	
K-100	N/A	N/A	Increases the pressure to the column pressure Efficiency: 75%
T-REC	N/A	N/A	Condenser: Total Reflux ratio: 4.3 Stages: 58 Feed tray: 58 (on-stage) Column pressure: 0.81 atm $\Delta P = 0.015 \text{ atm/tray}$
M-100	N/A	N/A	Adjust the steam-to-ethanol ratio to 3
E111	N/A	Evaporates water to steam	
P-102	N/A	Increases the pressure of the water to 1.2 atm	

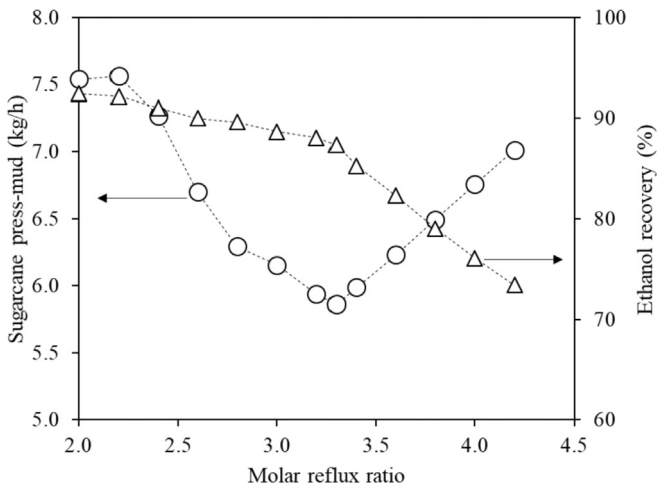
**Fig. 2.** Effect of the molar reflux ratio in the rectification column on the sugarcane press-mud consumption and ethanol recovery.

and (ii) life cycle inventory and life cycle impact assessment of power production from sugarcane press-mud. On the other hand, the data associated with the synthesis of catalysts includes: (i) mass and energy balances to synthesize all precursors and catalysts at laboratory scale and (ii) life cycle inventory of the catalysts precursors and catalysts.

Table 3

Description of main subroutines to produce power from raw bioethanol.

Aspen subroutine	Description	Conditions	Assumptions
R-101	Steam reforming of bioethanol modelled with a Gibbs reactor	T = 700 °C P = 1 atm	<ul style="list-style-type: none"> • The steam reforming reactor was modelled as Gibbs reactor. • A calculator block was employed to calculate H₂ yield (Y_{H₂}) based on the impurities concentration (x_i) and the following equation: $Y_{H_2} = -15.269 * x_i + 5.402$ [2] • CO, CO₂, CH₄, C₃H₆, C₄H₈, acetaldehyde, acetone, higher alcohols were including within the Gibbs analysis. • RhPt/CeO₂-SiO₂ was used as catalyst. • The amount of catalyst was calculated based on laboratory conditions.
R-102	CO removal from the syn-gas stream	T = 260 °C P = 1 atm	<ul style="list-style-type: none"> • The CO removal reactor was modelled as Gibbs reactor. • The temperature was set to 260 °C based on previous works. • A calculator block was employed to calculate the H₂ mole flow rate. • The O₂/CO ratio was adjusted to 0.9 using a Fortran statement. • Au-CuO/CeO₂ was used as catalyst. • The amount of catalyst was calculated similar to R-101.
Pressure swing adsorption (PSA)	H ₂ purification	T = 35 °C P = 15 bar H ₂ recovery = 80% H ₂ purity = 99.99 vol.%	<ul style="list-style-type: none"> • A double layer adsorbent formed by activated carbon and zeolite was used to clean the gas from the CO removal reactor. • The amount of adsorbent employed was assumed to be 0.85 g per kg of fuel based on a conceptual project developed in Germany to produce H₂ from biogas [6]. • A carbon-zeolite ratio of 8:2 was assumed to be used in the PSA stage according to literature.
Furnace	Burn the gases from the PSA unit to produce energy to heat up the reformer	Adiabatic	<ul style="list-style-type: none"> • The furnace was modelled with a Gibbs reactor. • CO₂, NO₂, NO, N₂O, CO, CH₄, H₂ were considered as output products. • Biogas, obtained from anaerobic digestion of mud, was employed as additional fuel to heat up some stream processes.
K-system	Compress the clean gas to PSA conditions	Polyprotic efficiency = 83%	<ul style="list-style-type: none"> • Compression system was built according to heuristics rules. • 4 compressors were included to increase the pressure from 1 to 15 atm. • Intermediate cooling was used. • The outlet temperature for the cooling system was selected according to the dew temperature of the gas.

Table 4

Heat and water-cooling demand of subroutines required to produce power from sugarcane press-mud under different scenarios of separation processes. Functional unit = 1 kWh of power.

Subroutine	Stage process	Heat demand (MJ/h)			Water cooling demand (kg/h)		
		Scenario 1	Scenario 2	Scenario 3	Scenario 1	Scenario 2	Scenario 3
P-101	Bioethanol purification	0.0044	0.00022	0.00018	NA	NA	NA
P-102	Bioethanol purification	NA	5.85E-5	4.67E-5	NA	NA	NA
K-100	Bioethanol purification	NA	NA	0.13	NA	NA	NA
E-100	Bioethanol purification	NA	1.82	1.46	NA	NA	NA
E-111	Bioethanol purification	41.79	2.96	2.36	NA	NA	NA
Condenser	Bioethanol purification	NA	NA	1.82	NA	NA	87.25
E-101	Syngas production	3.91	4.00	1.82	NA	NA	NA
E-113	Syngas production	11.08	8.11	2.61	NA	NA	NA
Q-R101	Syngas production	2.55	2.84	2.15	NA	NA	NA
E-102	Syngas production	4.99	2.82	2.06	239.05	135.29	98.77
Q-R102	Syngas production	11.08	2.82	2.61	NA	NA	NA
E-104	Syngas purification	2.11	1.25	0.86	101.2	59.84	41.27
E-105	Syngas purification	5.67	2.99	1.49	271.4	143.5	71.57
E-106	Syngas purification	0.49	0.31	0.24	23.67	14.93	11.62
E-107	Syngas purification	0.85	0.53	0.41	40.55	25.52	19.79
E-108	Syngas purification	0.29	0.18	0.14	14.00	8.83	6.85
K-101	Syngas purification	2.16	1.29	0.91	NA	NA	NA
K-102	Syngas purification	0.74	0.47	0.37	NA	NA	NA
K-103	Syngas purification	0.46	0.29	0.23	NA	NA	NA
K-104	Syngas purification	0.33	0.21	0.16	NA	NA	NA
E-109	Power production	0.04	0.04	0.04	NA	NA	NA

NA: No applied

Table 5

Subroutines employed to simulate the biomethane production from the residual waste and the Rankine Cycle.

Subroutine	Purpose
M-101	Adjusts the solid content to 10 wt.%
E-101	Heats up the mixture to 35 °C which is the anaerobic digestion temperature
S-101	Separates the water fraction from the biomass and separate the unreacted biomass fraction
R-101	RYIELD converts the non-conventional solid into C, H ₂ , O ₂ , N ₂ , water, and ash
R-102	RGIBBS calculates the biogas composition based on the minimization of the Gibbs Free Energy. CO ₂ , NH ₃ , CH ₄ , and water were considered as the main reaction products according to Eq. (1)
S-102	Separates the gas and liquid phase at the anaerobic digestion conditions, i.e., T = 35 °C, and atmospheric pressure
X-101	Simulates the leakage of the biogas during the anaerobic digestion
M-102	Mixes the biogas with the unrecovered gas from the absorption process
K-system	Increases the pressure to 10 bar which is the operating pressure of the high-pressure scrub system
T-101	Simulates the absorption tower (P = 10 bar, T = 20 °C, N = 7, L/V = 137)
T-102	Simulates the stripping tower (P=atmospheric, T = 20 °C, N = 10, L/V = 133)
S-103	Separates CH ₄ and CO ₂ from water
V-101	Reliefs the pressure from 10 bar to atmospheric pressure
P-101	Increases the water pressure to 10 bar. Efficiency = 85%
K-101	Decreases the pressure from 10 to 0.82 bar
Boiler	Produces steam in the Rankine cycle
P-103	Increases the water pressure to 10 bar in the Rankine cycle. Efficiency = 85%
E-105	Condenses the water in the Rankin cycle
K-103	Decreases the pressure from 10 to 0.04 bar. Efficiency = 85% isentropic

P = pressure, T = temperature, N = number of equilibrium stages, L/V = liquid-to-vapor molar ratio

2. Experimental Design, Materials and Methods

The detailed process to produce power from sugarcane press-mud is described in the related research paper [1]. Fig. 1 shows the main foreground systems. Detailed information about data acquisition, for each of the main units, is explained below.

2.1. Raw bioethanol production

Raw bioethanol production from sugarcane press-mud encompasses 3 main stages: i) pre-treatment; ii) fermentation; and iii) inoculum preparation. Material and energy flows for said processes were calculated based on experimental work. The mass was measured in each stage by using an analytical balance. Moreover, the energy flows were calculated based on the thermodynamic properties and the chemical composition. Chemical composition of liquid samples was quantified by gas chromatography, whereas the sugarcane press-mud composition was quantified by SGS (Société Générale de Surveillance), a certified laboratory [2]. Thermodynamic properties were retrieved from Aspen Plus V9 (Aspentech, Bedford, USA).

For the subsequent stages: bioethanol purification, syngas production and purification, and power production in a low temperature proton exchange membrane fuel cell (LT-PEMFC), Aspen plus V9 (Aspentech, Bedford, USA) was used and the non-random two liquid – Redlich-Kwong (NRTL-RK) thermodynamic package was employed.

2.2. Bioethanol purification

Bioethanol purification is the second stage, as shown in Fig. 1. Material and energy flows were retrieved from Aspen Plus V9. The design specification tool along with calculator subrou-

Table 6
Electricity generation in Colombia (MW).

Department	Electricity Generation (MW)										
	Cogeneration (Bagasse)	Wind	Hydropower	Solar	ACPM	Biogas	Carbon	Oil	Gas	Jet	Total
Antioquia			4733		353		9		1		5096
Arauca									5		5
Atlántico								88	912		1000
Bolívar				8				184	434		626
Boyacá			1020				343				1363
Caldas			606							44	650
Casanare									168		168
Cauca	30		353								383
Córdoba			338				437				775
Cundinamarca			2191			4	225		2		2422
Huila			951								951
La Guajira		18					286				304
Magdalena									610		610
Meta	20		2						40		61
Nariño			23								23
Norte de Santander							333				333
Putumayo			0						1		1
Quindío			4								4
Risaralda	17		28								45
Santander			838						446		1284
Tolima			204						4		208
Valle del Cauca	73		643	10	454		27				1206
Total	139.6	18.42	11933.71	17.98	807	3.95	1660.3	272	2621.89	44	17518.85

Table 7

Power grid distribution by department in Colombia (%).

Department	Power distribution (%)										Total
	Cogeneration (Bagasse)	Wind	Hydropower	Solar	ACPM	Biogas	Carbon	Oil	Gas	Jet	
Antioquia	0.0	0.0	92.9	0.0	6.9	0.0	0.2	0.0	0.0	0.0	100
Arauca	0.0	0.0	0.0	0.0	0.0	0.0	0.0	0.0	100.0	0.0	100
Atlantico	0.0	0.0	0.0	0.0	0.0	0.0	0.0	8.8	91.2	0.0	100
Bolivar	0.0	0.0	0.0	1.3	0.0	0.0	0.0	29.4	69.3	0.0	100
Boyacá	0.0	0.0	74.8	0.0	0.0	0.0	25.2	0.0	0.0	0.0	100
Caldas	0.0	0.0	93.2	0.0	0.0	0.0	0.0	0.0	0.0	6.8	100
Casanare	0.0	0.0	0.0	0.0	0.0	0.0	0.0	0.0	100.0	0.0	100
Cauca	7.8	0.0	92.2	0.0	0.0	0.0	0.0	0.0	0.0	0.0	100
Córdoba	0.0	0.0	43.6	0.0	0.0	0.0	56.4	0.0	0.0	0.0	100
Cundinamarca	0.0	0.0	90.4	0.0	0.0	0.2	9.3	0.0	0.1	0.0	100
Huila	0.0	0.0	100.0	0.0	0.0	0.0	0.0	0.0	0.0	0.0	100
La Guajira	0.0	6.1	0.0	0.0	0.0	0.0	93.9	0.0	0.0	0.0	100
Magdalena	0.0	0.0	0.0	0.0	0.0	0.0	0.0	0.0	100.0	0.0	100
Meta	32.5	0.0	2.6	0.0	0.0	0.0	0.0	0.0	64.9	0.0	100
Nariño	0.0	0.0	100.0	0.0	0.0	0.0	0.0	0.0	0.0	0.0	100
Norte de Santander	0.0	0.0	0.0	0.0	0.0	0.0	100.0	0.0	0.0	0.0	100
Putumayo	0.0	0.0	32.0	0.0	0.0	0.0	0.0	0.0	68.0	0.0	100
Quindio	0.0	0.0	100.0	0.0	0.0	0.0	0.0	0.0	0.0	0.0	100
Risaralda	37.4	0.0	62.6	0.0	0.0	0.0	0.0	0.0	0.0	0.0	100
Santander	0.0	0.0	65.3	0.0	0.0	0.0	0.0	0.0	34.7	0.0	100
Tolima	0.0	0.0	98.2	0.0	0.0	0.0	0.0	0.0	1.8	0.0	100
Valle del Cauca	6.0	0.0	53.3	0.8	37.6	0.0	2.2	0.0	0.0	0.0	100
Total general	0.797	0.105	68.119	0.103	4.606	0.023	9.477	1.553	14.966	0.251	100

Table 8

Assumptions required to build a dataset for chemicals manufacturing based on Ecoinvent framework [9].

Item	Description
Mass requirements	<ul style="list-style-type: none"> • Input materials were calculated based on stoichiometric reactions. • Reaction equations can be obtained from technical books like the Ullmann's Encyclopedia [11,12]
Energy consumption	<ul style="list-style-type: none"> • Energy and heat consumption were based on the information of several chemical companies in Germany. • Heat consumption was assumed to be 1.9840 MJ kg⁻¹ chemical. • Electricity consumption was assumed to be 1.2160 MJ kg⁻¹ chemical. • For exothermic reactions, heat was assumed to be 0 MJ kg⁻¹.
Water consumption	<ul style="list-style-type: none"> • Water consumption was based on the information of several chemical companies in Germany. • Cooling water was assumed to be 24 kg kg⁻¹ chemical. • Process water was assumed to be 6 kg kg⁻¹ chemical.
Emission to air/to water	<ul style="list-style-type: none"> • Emission to air was assumed to be 0.2% of the input material. • Water emission was calculated by mass balance.
Solid waste	<ul style="list-style-type: none"> • Solid wastes were excluded from this approach.
Transportation	<ul style="list-style-type: none"> • Standard distances were employed. • For most materials, 100 km with lorry and 200 – 600 km by train were assumed.
Infrastructure	<ul style="list-style-type: none"> • "Chemical plant, organics" in Ecoinvent is used as an approximation. • 4×10^{-10} units kg⁻¹ chemical was assumed. This number represents 50,000 ton per year and a plant lifetime of 50 years.

Table 9

Life cycle inventory for producing 1 kg of hydrolysate from sugarcane press-mud.

Stream name	Kind of stream	Unit	Value	Ecoinvent V3.4
Sugarcane press-mud ¹	Input	kg	2.432	Created by the user
Electricity ²	Input	MJ	1.306	Market for electricity, low voltage electricity, low voltage APOS, S - CO
Water process	Input	kg	0.1583	Water, unspecified natural origin, CO
Cooling water	Input	kg	11.1214	Water, cooling, unspecified natural origin, CO
Transport	Input	kg ^a ·km	72.96	Transport, freight, lorry 3.5 – 7.5 metric ton, EURO 4 transport, freight, lorry 3.5 – 7.5 metric ton, EURO 4 APOS, S - RoW
Steam	Emission to air	kg	0.0567	Water vapour, Emission to air/unspecified
Mud ³	Output	kg	1.5336	Created by the user

¹ Sugarcane press-mud is the product studied for its further conversion to power² Power grid electricity was build based on information retrieved from Colombian data³ Agroindustrial by-product obtained experimentally at the defined conditions

tines were used to define the operating conditions that warrant a steam-to-ethanol molar ratio (S/E) of 3. Three main scenarios were assessed, and the Aspen flowsheets are shown in the reference article. Besides, Fig. 2 shows the effect of molar reflux ratio on the sugarcane press-mud consumption and ethanol recovery in the rectification unit.

2.3. Syngas production and purification

Syngas production was carried out in a Gibbs reactor system which models the Ethanol Steam Reforming (ESR) by using RhPt/CeO₂-SiO₂, as catalyst at 700 °C. Table 3 shows the description of main subroutines employed to simulate the syngas production and purification. Since impurities

Table 10

Life cycle inventory for producing 1 kg of raw bioethanol from sugarcane press-mud hydrolysate.

Stream name	Kind of stream	Unit	Value	Ecoinvent V3.4
Hydrolysate	Input	kg	1.0864	Data from Table 9
Energy for fermentation ¹	Input	MJ	0.7958	Market for electricity, low voltage electricity, low voltage APOS, S - CO
Cooling water	Input	kg	11.627	Water, cooling, unspecified natural origin, CO
Peptone	Input	kg	0.0113	Chemical production, organic chemical organic APOS, S - GLO
Yeast extract	Input	kg	0.0158	Market for fodder yeast fodder yeast APOS, S - GLO
Ammonium sulfate	Input	kg	0.0011	Market for ammonium sulfate, as N ammonium sulfate, as N APOS, S - GLO
MgSO ₄ ·7H ₂ O	Input	kg	0.0009	Market for magnesium sulfate magnesium sulfate APOS, S - GLO
Ca ₃ (PO ₄) ₂	Input	kg	0.0004	Chemical production, inorganic Chemical, inorganic APOS, S -GLO
Freight ship transport	Input	kg*km	218.9246	Transport, freight, sea, transoceanic ship transport, freight, sea, transoceanic ship APOS, S -GLO
Freight road transport	Input	kg*km	26.55	Transport, freight, lorry 7.5 - 16 metric ton, EURO 4 transport, freight, lorry 7.5 - 16 metric ton, EURO4 APOS, S RoW
Freight road transport	Input	kg*km	1.76172	Transport, freight, lorry 7.5 - 16 metric ton, EURO 6 transport, freight, lorry 7.5 - 16 metric ton, EURO6 APOS, S RER
Inoculum	Input	kg	0.105	Data from Table 11
Steam	Emission to air	kg	0.0346	Water vapour, Emission to air/unspecified
CO ₂	Emission to air	kg	0.2011	Carbon dioxide, non-fossil, Emission to Air/unspecified

¹ Power grid electricity was build based on information retrieved from Colombian data

have an important effect on H₂ production, a linear model developed experimentally was used to forecast the H₂ production. [Fig. 3](#) shows the validation between experimental work and simulation data. Material data of output streams were directly gathered from the simulation to define the water and air emissions to the ecosphere. [Table 4](#) shows the energy demand and cooling requirements of each subroutine employed to produce power from raw bioethanol. These data were used to calculate LCI associated with heat, power, and cooling water requirements.

Syngas purification was performed in a CO-removal reactor at 260 °C over a Au-CuO/CeO₂ catalyst. RGIBBS subroutine was employed to model this operation. Both CO and H₂ conversion models, retrieved from experimental data at lab-scale [\[5\]](#), were used to forecast the clean gas composition. To produce pure H₂, a pressure swing adsorption (PSA) unit was employed. PSA unit was modelled by using a separator and defining both H₂ purity and recovery. Prior PSA, a train compressor system was employed to adjust the operating pressure of PSA (i.e., 15 atm). Moreover, intermediary cooling systems and separators were employed to remove the water present in the syngas stream.

Table 11

Life cycle inventory for producing 1 kg of yeast inoculum in YPD medium.

Stream	Kind of stream	Unit	Value	Ecoinvent 3.4
Peptone	Input	kg	0.0191	Chemical production, organic chemical, organic APOS, S -GLO
Yeast extract	Input	kg	0.00955	Market for fodder yeast [fodder yeast] APOS, S - GLO
Lyophilized yeast	Input	kg	0.00061	Table 12
Glucose	Input	kg	0.0191	Glucose production glucose APOS, S -RoW
Electrical energy ¹	Input	MJ	0.57321	Market for electricity, low voltage electricity, low voltage APOS, S - CO
Water cooling	Input	kg	5.64496	Water, cooling, unspecified natural origin, CO
Water process	Input	kg	0.95224	Water, unspecified natural origin, CO
Freight ship	Input	kg* km	386.95328	Transport, freight, sea, transoceanic ship transport, freight, sea, transoceanic ship APOS, S -GLO
Freight road	Input	kg* km	43.524	Transport, freight, lorry 7.5 - 16 metric ton, EURO 4 transport, freight, lorry 7.5 - 16 metric ton, EURO4 APOS, S RoW
Freight road	Input	kg* km	0.13664	Transport, freight, lorry 7.5 - 16 metric ton, EURO 6 transport, freight, lorry 7.5 - 16 metric ton, EURO6 APOS, S RER
Carbon dioxide	Emission to air	kg	0.00934	Carbon dioxide, Emission to air, unspecified

¹ Power grid electricity was build based on information retrieved from Colombian data

Table 12

Life cycle inventory for producing 1 kg of lyophilized yeast [3].

Stream	Kind of stream	Unit	Value	Ecoinvent 3.4
Molasses, from sugar beet	Input	kg	3.90	Market for molasses, from sugar beet [molasses, from sugar beet] APOS, S - GLO
Ammonia	Input	kg	0.08	Market for ammonia, liquid [ammonia liquid] APOS, S - RER.
P ₂ O ₅	Input	kg	0.03	Market for phosphate fertilizer, as P2O5 [phosphate fertilizer, as P2O5] APOS, S - GLO
Steam	Input	MJ	13.0	Market for heat, from steam, in chemical industry [heat, from steam, in chemical industry] APOS, S - RER
Electricity	Input	MJ	3.10	Market for electricity, low voltage electricity, low voltage APOS, S - FR

2.4. Fuel cell simulation

The electrochemical behavior of LT-PEMFC was modelled in Aspen Plus V9 along with FORTRAN statements based on the model recommended in the literature [16]. Moreover, the anode was modelled using a SEPARTOR (SEP), while the cathode was modelled using an adiabatic RGIBBS. The SEP splits the H₂ fraction that is used in the LT-PEMFC and the RGIBBS simulates

Table 13

Life cycle inventory for producing 1 kg of bioethanol (steam-to-ethanol ratio = 3).

Stream name	Kind of stream	Unit	Scenario 1	Scenario 2	Scenario 3	Ecoinvent 3.4
Crude bioethanol	Input	kg	61.0347	5.5399	6.3524	Table 10
Electrical energy	Input	MJ	0.0019	0.0002	0.1424	Market for electricity, low voltage electricity, low voltage APOS, S - CO
Process water	Input	kg	NA	0.8530	1.4915	Water, unspecified natural origin, CO
Cooling water	Input	kg	NA	NA	94.5747	Water, cooling, unspecified natural origin, CO
Heat	Input	MJ	17.5483	2.2320	2.5629	Table 16
Water	Emission to water	kg	55.3335	5.3866	6.7667	Water, emission to water, unspecified
Ethanol	Emission to water	kg	4.6034	9.128E-05	0.0666	Ethanol, emission to water, unspecified
Ethyl acetate	Emission to water	kg	0.0012	4.608E-35	2.63E-06	Ethyl acetate, emission to water, unspecified
1-propanol	Emission to water	kg	0.0043	1.248E-11	5.16E-04	1-propanol, emission to water, unspecified
2-methyl-1-propanol	Emission to water	kg	0.0072	3.545E-13	8.74E-04	2-methyl-1-propanol, emission to water, unspecified
3-methyl-1-butanol	Emission to water	kg	0.0139	5.879E-17	1.78E-03	3-methyl-1-butanol, emission to water, unspecified
Acetic acid	Emission to water	kg	0.0714	0.006153	7.47E-03	Acetic acid, emission to water, unspecified

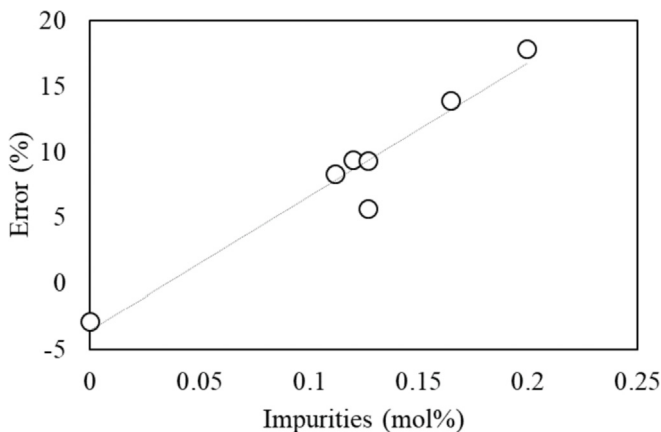
**Fig. 3.** Error determination between experimental and simulated results in terms of H₂ purity in the syngas stream. Experimental data were retrieved from [2].

the chemical reaction between H₂ and oxygen to yield water and heat as main products. RGIBBS was considered adiabatic. The design specification tool was used to calculate the cooling air needed to keep the fuel cell temperature at 70 °C. Heat was not considered as by-product. Fig. 4 shows the validation of the simulation according to the polarization curves between a commercial Ballard Mark V LT-PEMFC and Aspen results.

Table 14

Life cycle inventory for producing 1 kg of clean syngas.

Stream name	Kind of stream	Unit	Scenario 1	Scenario 2	Scenario 3	Ecoinvent 3.4
Bioethanol (S/E=3)	Input	kg	0.2831	0.2750	0.2902	Table 13
RhPt/CeO ₂ -SiO ₂	Input	kg	4.13E-06	4.04E-06	4.27E-06	Table 25
AuCuO/CeO ₂	Input	kg	4.13E-06	4.04E-06	4.27E-06	Table 26
Carrier (N ₂)	Input	kg	0.63098	0.6141	0.6494	Market for nitrogen, liquid [nitrogen, liquid] APOS, S - RoW
Quartz	Input	kg	1.03E-5	1.01E-5	1.07E-5	Market for glass tube, borosilicate [glass tube, borosilicate] APOS, S - GLO
Oxygen	Input	kg	0.0859	0.1109	0.0634	Market for oxygen, liquid [oxygen, liquid] APOS, S - RoW
Cooling water	Input	kg	28.4154	28.040	31.0694	Water, cooling, unspecified natural origin, CO
Energy	Input	MJ	0.3036	0.5890	1.2506	Table 16
Transport	Input	kg*km	0.0037	0.0036	0.0038	Transport, freight, light commercial vehicle [transport, freight, light commercial vehicle] APOS, S - RoW

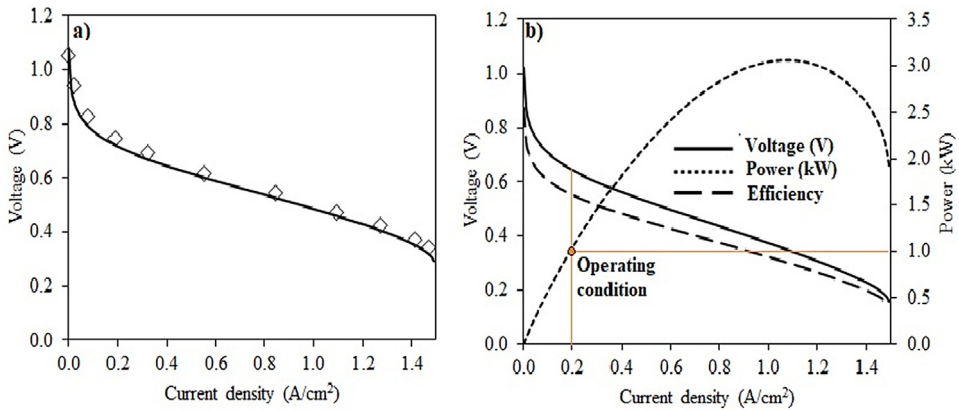

Fig. 4. a) Validation of a Ballard Mark V fuel cell. Continuous line: Aspen model; \diamond Experimental data. Fuel cell parameters: $T = 343$ K, $P = 1$ atm, $P_{H_2} = 1$ atm; $P_{O_2} = 1$ atm; $A = 50.6$ cm²; and $n = 1$. b) Fuel cell performance at the operating conditions of the power production plant. $T = 348$ K, $P = 0.81$ atm.

2.5. Aspen simulation to produce biomethane from residual biomass

Fig. 5 shows the simulation to produce biomethane from the solid fraction of sugarcane press-mud. Herein, a theoretical estimation of the biogas production by anaerobic digestion was used according to the Boyle's formula (Eq. 1) and the following assumptions: (i) constant temperature and perfect mixing; (ii) ideal bacterial condition; (iii) biomass is modelled from ultimate analysis; (iv) products reaction include only CH₄, CO₂, NH₃, and H₂S; and (v) no accumulation of ashes [7]. The non-random two liquids (NRTL) thermodynamic model was used along with Henry law. Biogas upgrade to biomethane was done by high pressure water scrubbing. Proximate and ultimate analysis were included in the simulation. The solid fraction was created as a non-conventional solid. HCOALGEN and DCOALGT were used to estimate the enthalpy

Table 15Life cycle inventory for producing 1 kg of H₂ (99.99 vol.%).

Stream name	Kind of stream	Unit	Scenario 1	Scenario 2	Scenario 3	Ecoinvent 3.4
Clean syngas	Input	kg	116.389	66.208	43.993	Table 14
Zeolite	Input	kg	1.70E-4	1.70E-4	1.70E-4	Zeolite production, powder zeolite, powder APOS, S - RoW
Activated carbon	Input	kg	6.8E-4	6.8E-4	6.8E-4	Activated carbon production, granular from hard coal Activated carbon, granular APOS, S - RoW
Cooling water	Input	kg	6236.78	3466.65	2090.99	Water, cooling, unspecified natural origin, CO
Electrical power	Input	MJ	51.1308	31.099	23.036	Market for electricity, low voltage electricity, low voltage APOS, S - CO
Freight ship transport	Input	kg*km	2.527	2.527	2.527	Transport, freight, sea, transoceanic ship transport, freight, sea, transoceanic ship APOS, S -GLO
Freight road transport	Input	kg*km	0.7637	0.764	0.764	Transport, freight, lorry 7.5 - 16 metric ton, EURO 4 transport, freight, lorry 7.5 - 16 metric ton, EURO4 APOS, S RoW
Exhaust gas	Output	kg	97.029	56.570	40.415	Avoided product
Water	Emission to water	kg	17.7408	8.322	2.475	Water, emission to water, unspecified
Carbon monoxide	Emission to water	kg	5.78E-4	0.0004	5.35E-05	Carbon monoxide, emission to water, unspecified
Carbon dioxide	Emission to water	kg	0.3241	0.1962	0.0610	Carbon dioxide, emission to water, unspecified
Methane	Emission to water	kg	0.0261	NR	NR	Methane, emission to water, unspecified
Nitrogen	Emission to water	kg	0.0237	0.0115	0.0032	Nitrogen, emission to water, unspecified
Water	Emission to air	kg	0.0054	0.0022	7.30E-4	Water vapor, emission to air, unspecified
Carbon monoxide	Emission to air	kg	0.0019	0.0010	1.73E-04	Carbon monoxide, non-fossil, emission to air, unspecified
Carbon dioxide	Emission to air	kg	0.1172	0.0605	0.022	Carbon dioxide, non-fossil, emission to air, unspecified
Methane	Emission to air	kg	0.0150	NR	NR	Methane, emission to air, unspecified
Nitrogen	Emission to air	kg	0.1051	0.0434	0.014	Nitrogen, emission to air, unspecified

and density of the biomass, respectively. FORTRAN statements were used along with simulation to adjust input and outputs of the flowsheet according to the requirements. Table 5 shows the description of the subroutines described in Fig. 5.

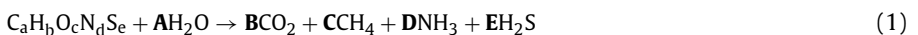

Table 16
Power from burner for producing 1 MJ of energy.

Stream name	Kind of stream	Unit	Scenario 1	Scenario 2	Scenario 3	Ecoinvent 3.4
Exhaust anode	Input	kg	0.00033	0.0025	0.0023	Table 17
Exhaust gas	Input	kg	0.1582	0.7103	0.4608	Table 15
Air	Input	kg	0.3428	0.1425	0.3512	Resource/in Air
Biomethane	Input	kg	0.0190	0.0079	0.0195	Table 18
Steam	Emission to air	kg	0.0551	0.0684	0.0861	Water vapour, emission to air, unspecified
Carbon dioxide	Emission to air	kg	0.0612	0.0997	0.1109	Carbon dioxide, non-fossil, emission to air, unspecified
Nitrogen	Emission to air	kg	0.1051	0.6191	0.5949	Nitrogen, emission to air, unspecified
Oxygen	Emission to air	kg	2.51E-7	4.71E-14	5.57E-13	Oxygen, in air, Emission to air, unspecified
Carbon monoxide	Emission to air	kg	2.15E-2	7.60E-2	4.17E-2	Carbon monoxide, non-fossil, emission to air, unspecified
Ammonia	Emission to air	kg	2.10E-8	9.62E-7	3.89E-7	Ammonia, emission to air, unspecified
Nitrogen dioxide	Emission to air	kg	1.65E-11	1.32E-18	1.65E-17	Nitrogen dioxide, emission to air, unspecified
Dinitrogen monoxide	Emission to air	kg	2.57E-10	1.53E-14	6.03E-14	Dinitrogen monoxide, emission to air, unspecified
Nitrogen monoxide	Emission to air	kg	3.93E-6	2.10E-10	8.44E-10	Nitrogen monoxide, emission to air, unspecified
Methane	Emission to air	kg	8.88E-14	6.19E-9	3.68E-10	Methane, emission to air, unspecified
LPG	Avoided product	kg	0.3166	0.1542	0.0732	Market for liquefied petroleum gas [liquefied petroleum gas] APOS, S, RoW

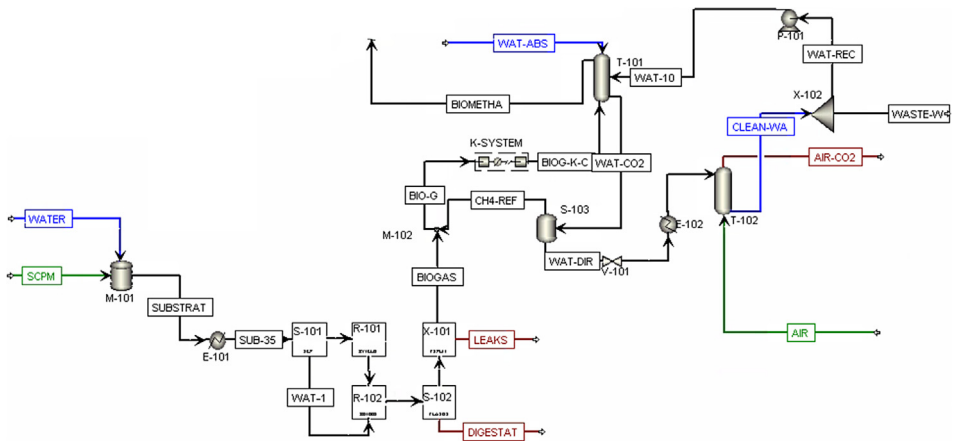

Fig. 5. Aspen flowsheet for the simulation of biomethane using sugarcane press-mud. E: Heat exchanger; S: Separator; M: Mixer; X: Component splitter; T: Absorption/Stripping towers; P: pumps; K: Compressor system.

Table 17

Life cycle inventor for producing 1 kWh in a low-temperature proton exchange membrane fuel cell.

Stream	Kind of stream	Unit	Value	Ecoinvent 3.4
Hydrogen (99.99 vol.%)	Input	kg	0.073	Table 15
Air fuel cell	Input	kg	123.24	Resource/in Air
Electricity	Input	MJ	0.042	Market for electricity, low voltage electricity, low voltage APOS, S - CO
Fuel cell stack	Input	unit	1.56E-5	Market for fuel cell, stack polymer electrolyte, 2 kW electrical, future fuel cell stack polymer electrolyte membrane, 2 kW electrical, future APOS, S - GLO
Oceanic transport	Input	kg* km	8.666	Transport, freight, sea, transoceanic ship transport, freight, sea, transoceanic ship APOS, S - GLO
Freight transport	Input	kg* km	1.202	Transport, freight, lorry 3.5 - 7.5 metric ton, EURO4 transport, freight, lorry 3.5 - 7.5 metric ton, EURO 4 APOS, S - RoW
Exhaust anode	Output	kg	0.014	Avoided product
Water	Emission to air	kg	2.234	Water vapour, emission to air, unspecified
Nitrogen	Emission to air	kg	93.571	Nitrogen, emission to air, unspecified
Oxygen	Emission to air	kg	28.059	Oxygen, in air, Emission to air, unspecified

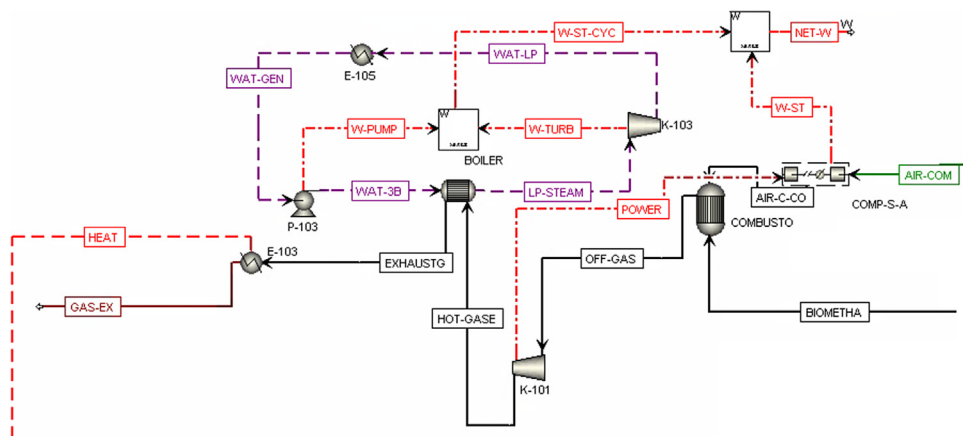

Fig. 6. Aspen flowsheet to produce power and heat from bi methane by using a Rankine cycle.

Fig. 6 shows the aspen flowsheet diagram to produce combined heat and power in a Rankine cycle. Heat and power were used to supply the energy demand of the bi methane production process described in Fig. 5.

Table 18
Life cycle inventory for producing 1 kg of biomethane from mud.

Stream	Kind of stream	Unit	Value	Ecoinvent 3.4
Mud	Input	kg	13.6863	Table 9
Water	Input	kg	218.938	Water, unspecified natural origin, CO
Air	Input	m ³	0.3668	Market for compressed air, 600 kPa gauge compressed air, 600 kPa gauge APOS, S – GLO
Energy	Input	MJ	4.1234	Table 12
Cooling water	Input	kg	234.53	Water, cooling, unspecified natural origin, CO
Carbon dioxide	Emission to air	kg	1.7255	Carbon dioxide, non-fossil, emission to air, unspecified
Methane	Emission to air	kg	0.0562	Methane, non-fossil, emission to air, unspecified
Ammonia	Emission to air	kg	0.0047	Ammonia, emission to air, unspecified
Water	Emission to air	kg	0.0849	Water vapour, emission to air, unspecified
Oxygen	Emission to air	kg	0.7565	Oxygen, in air, emission to air, unspecified
Nitrogen	Emission to air	kg	2.4948	Nitrogen, emission to air, unspecified
Carbon dioxide	Emission to water	kg	2.03E-13	Carbon dioxide, emission to water, fresh water
Methane	Emission to water	kg	1.11E-29	Methane, emission to water, unspecified
Ammonia	Emission to water	kg	0.0024	Ammonia, emission to water, unspecified
Water	Emission to water	kg	9.6253	Water, emission to water, unspecified
Nitrogen	Emission to water	kg	0.0001	Nitrogen, emission to water, unspecified
Digestate	Output	kg	42.2517	Avoided product as ammonium nitrate

2.6. Modelling of Colombia power grid in different regions

Colombia power grid was modelled by modifying the process unit “market for high voltage, APOS, U, CO” from Ecoinvent database V3.4 in the software OpenLCA V1.9. Different power grids could be modelled by using the data present in Table 6 to calculate the power share, as shown in Table 7.

2.7. Modelling LCI of catalysts

Table 8 shows the assumptions made to calculate LCI of catalysts based on the Ecoinvent guidelines [9]. Besides, the use of scientific reports and lab-scale data were used to build the LCI [2,5]. Fig. 7 shows the block flow diagrams to synthesize RhPt/CeO₂-SiO₂ and Au-CuO/CeO₂ catalysts at lab-scale. Fig. 8 shows the block flow diagrams to synthesize main precursors to yield the aforementioned catalysts. All the block flow diagrams were built based on scientific reports. All the precursors were assumed to be manufactured in Germany, except cerium nitrate which was assumed to be synthesized in China. Detailed information of material flow calculation is shown in the up-coming section.

Table 19

Life cycle inventory for producing 1 kWh of power in a Rankine cycle.

Stream	Kind of stream	Unit	Value	Ecoinvent 3.4
Biomethane	Input	kg	0.0683	Table 18
Air	Input	m ³	0.0029	Market for compressed air, 1000 kPa gauge compressed air, 1000 kPa gauge APO,S - GLO
Water	Input	kg	0.5542	Water, unspecified natural origin, CO
Steam	Emission to air	kg	0.1357	Water vapour, Emission to air, unspecified
Carbon dioxide	Emission to air	kg	0.1718	Carbon dioxide, from soil or biomass stock
Methane	Emission to air	kg	5.45E-20	Methane, from soil or biomass stock
Ammonia	Emission to air	kg	3.55E-10	Ammonia, emission to air, unspecified
Oxygen	Emission to air	kg	0.0371	Oxygen in air, emission to air, unspecified
Nitrogen	Emission to air	kg	0.9199	Nitrogen, emission to air, unspecified
Dinitrogen monoxide	Emission to air	kg	1.10E-06	Dinitrogen monoxide, emission to air, unspecified
Nitrogen monoxide	Emission to air	kg	0.0050	Nitrogen monoxide, emission to air, unspecified
Nitrogen dioxide	Emission to air	kg	1.11E-05	Nitrogen dioxide, emission to air, unspecified
Carbon monoxide	Emission to air	kg	6.92E-04	Carbon monoxide, emission to air, unspecified

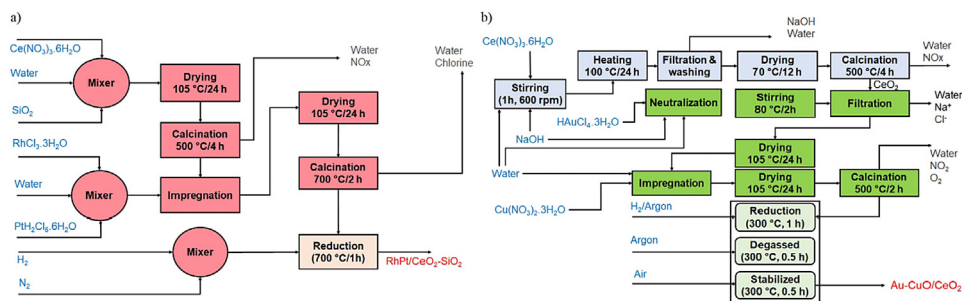
**Fig. 7.** System boundaries to produce a) 1 g of RhPt/CeO₂-SiO₂ and b) 1 g of Au-CuO/CeO₂ catalysts.

2.7.1. Synthesis of Rhodium chloride trihydrate (RhCl₃·3H₂O)

Fig. 8a depicts the block flow diagram to synthesize RhCl₃·3H₂O based on literature review, described by Kleinberg [10]. The manufacturing of RhCl₃·3H₂O starts with the mining of rhodium (Rh), a noble metal which is found in the platinum group metal (PGM) ore in small quantities (i.e., 0.01%). After mining, synthesis process is carried out. The process involves four reactions (Eqs. (2) – (5)) and the overall yield is 1.64 kg RhCl₃·3H₂O kg⁻¹ metallic Rh [10]. Stoichiometric relations and assumptions described in Table 8 were used to build the complete LCI to produce RhCl₃·3H₂O.

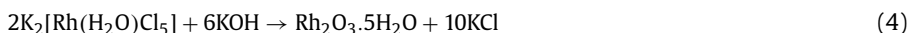
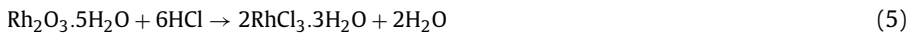

Table 20
Life cycle inventory for producing 1 kg H₂PtCl₆·6H₂O.

Input	kind of flow	Unit	Value	Ecoinvent V3.4
Pt metallic	Input	kg	0.3764	Platinum group metal mine operation, ore with high palladium [platinum] APOS, S -RU
HCl	Input	kg	0.1412	Market for Hydrochloric acid, without water, in 30% solid state, APOS S-RER
Cl ₂	Input	kg	0.2747	Market for chlorine, gaseous, APOS S-RER
Water cooling, unspecified	Resource	m ³	0.024	Water, cooling, unspecified natural origin, DE
Water process, unspecified	Resource	m ³	0.00023	Water, unspecified natural origin, DE
Electricity	Input	MJ	1.216	Market for electricity, medium voltage electricity, medium voltage APOS, S, DE
Heat	Input	MJ	1.984	Heat and power cogeneration, natural gas, conventional power plant, 100 MW electrical heat, district or industrial, natural gas APOS, S - DE
Freight transport	Input	ton*km	1.2295	Market for transport, freight, lorry > 32 metric ton, EURO 6 transport, freight, lorry >32 metric ton, EURO 6 APOS,S-GLO
Rail train transport	Input	ton*km	0.193	Market for transport, freight train Transport freight train APOS, S - Europe without Switzerland
Infrastructure	Input	Unit	4.00E-10	Market for chemical factory, organics chemical factory organics APOS, S, GLO
HCl	Emission to air	kg	0.00028	Hydrogen chloride, emission to air, unspecified
Water vapour	Emission to air	kg	0.2658	Water vapour, emission to air, unspecified
Cl ₂	Emission to air	kg	0.000549	Chlorine, emission to air, unspecified
Heat	Emission to air	MJ	1.216	Heat, emission to air, unspecified



2.7.2. Synthesis of acid Hexachloroplatinic hexahydrate (PtH₂Cl₆·6H₂O)

Fig. 8b shows the block flow diagram to synthesize PtH₂Cl₆·6H₂O. Similar as Rh, the process starts from the mining and extraction of platinum (Pt) in the PGMs. Therefore, similar transport distances were assumed. Synthesis process was done according to the Ullman's Encyclopedia where metallic Pt is dissolved in a 7M solution HCl and Cl₂, as shown in Eq. (6). Conversion of both HCl and Cl₂ was assumed to be 100% [11]. Production of the hydrated salt was done through an evaporation-crystallization system.



2.7.3. Synthesis of copper nitrate trihydrate (Cu(NO₃)₂·3H₂O)

Fig. 8c displays the manufacturing process to produce Cu(NO₃)₂·3H₂O. The process starts from the mining and extraction of metallic copper (Cu). After mining, Cu is mixed with nitric

Table 21Life cycle inventory for producing 1 kg of $\text{RhCl}_3 \cdot 3\text{H}_2\text{O}$.

Input	kind of flow	Unit	Value	Ecoinvent V3.4
Rh metallic	Input	kg	0.6098	Market for rhodium, APOS S-GLO
Cl_2	Input	kg	0.4489	Market for chlorine, gaseous [chlorine, gaseous] APOS, S - RER
KCl	Input	kg	1.6798	Potassium chloride production [potassium chloride as K_2O] APOS, S -RER
KOH	Input	kg	0.6726	Potassium hydroxide production [potassium hydroxide] APOS, S -RER
HCl	Input	kg	0.4199	Market for Hydrochloric acid, without water, in 30% solid state, APOS S-RER
Water cooling, unspecified	Resource	m^3	0.0240	Water, cooling, unspecified natural origin, DE
Water process, unspecified	Resource	m^3	0.0360	Water, unspecified natural origin, DE
Freight transport	Input	$\text{ton} \cdot \text{km}$	4.2160	Market for transport, freight, lorry > 32 metric ton, EURO 6 [transport, freight, lorry >32 metric ton, EURO 6]APOS,S-GLO
Rail train transport	Input	$\text{ton} \cdot \text{km}$	1.7650	Market for transport, freight train [Transport freight train] APOS, S - Europe without Switzerland
Electricity	Input	MJ	1.2160	Market for electricity, medium voltage electricity, medium voltage APOS, S, DE
Heat	Input	MJ	1.9840	Heat and power cogeneration, natural gas, conventional power plant, 100 MW electrical [heat, district or industrial, natural gas] APOS, S - DE
Infrastructure	Input	Unit	4E-10	Market for chemical factory, organics chemical factory organics APOS, S, GLO
Chlorine	Emission to air	kg	0.0009	Chlorine, emission to air, unspecified
Steam	Emission to air	kg	0.7534	Water vapour, emission to air, unspecified
HCl	Emission to air	kg	0.0042	Hydrogen chloride, emission to air, unspecified
Heat	Emission to air	MJ	1.2160	Heat, waste, emission to air, unspecified
Cl ions	Emission to water	kg	0.5179	Chlorine, emission to water, unspecified
Rh ions	Emission to air	kg	0.0206	Rhodium, emission to air, unspecified
Water	Emission to water	m^3	0.0364	Wastewater, m^3 , emission to water, unspecified
K ions	Emission to water	kg	1.1408	Potassium, emission to water, unspecified

Table 22
Life cycle inventory for producing 1 kg of Ce(NO₃)₃·6H₂O.

Input	kind of flow	Unit	Value	Ecoinvent V3.4
Bastnäsite	Input	kg	0.6120	Rare earth production, 70% REO, from bastnäsite rare earth production, 70% REO from bastnäsite APOS, S - CN
HNO ₃	Input	kg	1.1203	Nitric acid production, product in 50% solution state nitric acid, without water, in 50% solution APOS, S -RoW
TBP	Input	kg	0.0075	Market for chemical, organic chemical organic APOS, S - GLO
H ₂ SO ₄	Input	kg	0.3164	Sulfuric acid production sulfuric acid APOS,S
NaCl	Input	kg	0.8840	Market for sodium chloride, powder sodium chloride APOS, S - GLO
NaOH	Input	kg	0.1177	Market for sodium hydroxide, without water, in 50% solution state sodium hydroxide without water, in 50% solution state APOS, S -GLO
HCl	Input	kg	0.0840	Market for Hydrochloric acid, without water, in 30% solid state, APOS S-RoW
Process water	Input	m ³	0.0004	Water, unspecified natural origin, CN
Cooling water	Input	m ³	0.0240	Water, cooling, unspecified natural origin, CN
Heat	Input	MJ	0.0008	heat and power cogeneration, hard coal heat, district or industrial, other than natural gas APOS, S - RoW
Electricity	Input	MJ	0.0078	Market group for electricity, medium voltage electricity, medium voltage APOS, S- CN
Steam	Input	MJ	0.2106	Market for steam, in chemical industry heat from steam, in chemical industry APOS, S - RoW
Freight transport	Input	ton*km	0.3142	Market for transport, freight, lorry > 32 metric ton, EURO 5 transport, freight, lorry >32 metric ton, EURO 5 APOS,S-GLO
Rail train transport	Input	ton*km	0.6284	Market for transport, freight train transport freight train APOS,S-CN
Infrastructure	Input	Unit	4E-10	Market for chemical factory, organics chemical factory organics APOS, S, GLO
Sodium	Emission to water	kg	0.4103	Sodium, emission to water, unspecified
Sulfate	Emission to water	kg	0.2152	Sulfate, emission to water, unspecified
Fluorine	Emission to water	kg	0.0320	Fluorine, emission to water, unspecified
Chlorine	Emission to water	kg	0.5021	Chlorine, emission to water, unspecified
Water	Emission to water	m ³	0.0001	Wastewater, m ³ , emission to water, unspecified

Table 23Life cycle inventory for producing 1 kg of $\text{HAuCl}_4 \cdot 3\text{H}_2\text{O}$.

Input	kind of flow	Unit	Value	Ecoinvent V3.4
Gold	Input	kg	0.540	Gold production gold APOS, S - RoW
HNO_3	Input	kg	13.57	Nitric acid production, product in 50% solution state nitric acid, without water, in 50% solution APOS, S -RER
HCl	Input	kg	68.07	Market for Hydrochloric acid, without water, in 30% solid state, APOS S-RER
Water cooling	Input	m^3	0.0240	Water, cooling, unspecified natural origin, DE
Water process	Input	m^3	0.0150	Water, unspecified natural origin, DE
Electricity	Input	MJ	1.2160	Market for electricity, medium voltage electricity, medium voltage APOS, S, DE
Freight transport	Input	Ton*km	3.0762	Market for transport, freight, lorry > 32 metric ton, EURO 6 transport, freight, lorry >32 metric ton, EURO 6 APOS,S-GLO
Rail train transport	Input	Ton*km	21.755	Market for transport, freight train Transport freight train APOS, S - Europe without Switzerland
Infrastructure	Input	Unit	4E-10	Market for chemical factory, organics chemical factory organics APOS, S, GLO
Hydrogen chloride	Emission to air	kg	0.3660	Hydrogen chloride, emission to air, unspecified
Nitrogen dioxide	Emission to air	kg	0.3772	Nitrogen dioxide, emission to air, unspecified
Nitrogen monoxide	Emission to air	kg	5.9048	Nitrogen monoxide, emission to air, unspecified
Chlorine	Emission to air	kg	17.567	Chlorine, emission to air, unspecified
Heat	Emission to air	MJ	1.2160	Heat, waste, emission to air, unspecified
Gold ions	Emission to water	kg	0.0385	Gold, emission to water, unspecified
Water	Emission to water	m^3	0.0105	Wastewater, m^3 , emission to water, unspecified
Chlorine ions	Emission to water	kg	0.0139	Chlorine, emission to water, unspecified

acid (HNO_3) according to the Ullman's encyclopedia [12]. The reaction between Cu and HNO_3 is shown in Eq. (7). The effluent from the reaction step is evaporated and concentrated to obtain crystals of $\text{Cu}(\text{NO}_3)_2 \cdot 3\text{H}_2\text{O}$. To determine the amount of crystal, solubility of the hydrated copper salt was considered as 77.4 g $\text{Cu}(\text{NO}_3)_2 \cdot 3\text{H}_2\text{O}$ per 100 g water.

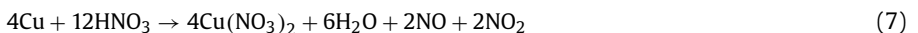

2.7.4. Synthesis of Acid chloroauric trihydrate ($\text{HAuCl}_4 \cdot 3\text{H}_2\text{O}$)

Fig. 8d shows the block flow diagram to produce $\text{HAuCl}_4 \cdot 3\text{H}_2\text{O}$, which starts with the mining and extraction of gold (Au) from the ore. The process to convert Au into $\text{HAuCl}_4 \cdot 3\text{H}_2\text{O}$ was described by Gross [14]. Firstly, Au is diluted in aqua regia (75% HCl, 25% HNO_3) to produce HAuCl_4 according to Eq. (8). However, a side reaction takes place between HCl and HNO_3 (Eq. (9)). The reaction between Au and aqua regia is highly exothermic. Therefore, heat was assumed to be 0

Table 24Life cycle inventory for producing 1 kg of $\text{Cu}(\text{NO}_3)_2 \cdot 3\text{H}_2\text{O}$.

Input	kind of flow	Unit	Value	Ecoinvent V3.4
Cu metallic	Input	kg	0.2930	Copper production, primary copper APOS, S, RER
HNO_3	Input	kg	0.8654	Nitric acid production, product in 50% solution state nitric acid, without water, in 50% solution APOS, S -RER
Electricity	Input	MJ	1.2160	Market for electricity, medium voltage electricity, medium voltage APOS, S, DE
Heat	Input	MJ	1.9840	Heat and power cogeneration, natural gas, conventional power plant, 100 MW electrical heat, district or industrial, natural gas APOS, S - DE
Freight transport	Input	Ton*km	0.5460	Market for transport, freight, lorry > 32 metric ton, EURO 6 transport, freight, lorry >32 metric ton, EURO 6 APOS,S-GLO
Rail train transport	Input	Ton*km	0.5192	Market for transport, freight train Transport freight train APOS, S - Europe without Switzerland
Cooling water	Input	m^3	0.0240	Water, cooling, unspecified natural origin, DE
Process water	Input	m^3	0.0009	Water, unspecified natural origin, DE
Infrastructure	Input	Unit	4E-10	Market for chemical factory, organics chemical factory organics APOS, S, GLO
Nitrogen monoxide	Emission to air	kg	0.0652	Nitrogen monoxide, emission to air, unspecified
Nitrogen dioxide	Emission to air	kg	0.1000	Nitrogen dioxide, emission to air, unspecified
Heat	Emission to air	MJ	1.2160	Heat, waste, emission to air, unspecified
Steam	Emission to air	kg	0.2231	Water vapour, emission to air, unspecified
Copper ions	Emission to water	kg	0.0286	Copper, emission to water, unspecified
Nitrates	Emission to water	kg	0.0561	Nitrates, emission to water, unspecified
Water	Emission to water	kg	6.80E-5	Water, emission to water, unspecified

and no energy source is required. Besides, water consumption was estimated according to the methodology process showed by Gross [14].

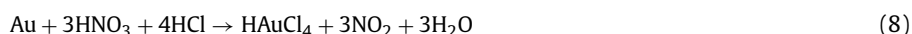

2.7.5. Synthesis of cerium nitrate hexahydrate ($\text{Ce}(\text{NO}_3)_3 \cdot 6\text{H}_2\text{O}$)

$\text{Ce}(\text{NO}_3)_3 \cdot 6\text{H}_2\text{O}$ is the precursor to produce the catalyst support in both cases. Cerium is a rare earth element and is mainly found on Bastnäsite ores (50%) in China. Hence, energy consumption was based on the Chinese power grid available in Ecoinvent V3.4.



Table 25Life cycle inventory for producing 1 g RhPt/CeO₂-SiO₂.

Input	kind of flow	Unit	Value	Ecoinvent V3.4
Ce(NO ₃) ₃ .6H ₂ O	Input	g	2.3431	Table 22
RhCl ₃ .3H ₂ O	Input	g	0.0102	Table 20
PtH ₂ Cl ₆ .6H ₂ O	Input	g	0.0106	Table 21
SiO ₂	Input	g	0.0633	Silica sand production [silica sand] APOS, S-DE
Water tap deionized	Input	g	5.9341	Market for water, deionized, from tap water, at user [water deionized, from tap water, at user] APOS, S - RoW
Rail train transport	Input	kg*km	0.0496	Market for transport, freight train [Transport freight train] APOS, S - Europe without Switzerland
Rail train transport	Input	kg*km	6.1765	Market for transport, freight train transport freight train APOS,S-CN
Oceanic transport	Input	kg*km	71.6836	Market for transport, freight, sea, transoceanic ship [transport, freight, sea, transoceanic ship] APOS,S -GLO
Freight transport	Input	kg*km	1.2727	Market for transport, freight, lorry, 3.5-7.5 metric ton, EURO 3 [transport, freight, lorry 3.5 - 7.5 metric ton, EURO 3]APOS, S -GLO
Light commercial transport	Input	Kg*km	0.0585	Market for transport, freight, light commercial vehicle [transport, freight commercial vehicle] APOS, S -GLO
Hydrogen	Input	g	0.1120	Market for hydrogen, liquid [hydrogen, liquid] APOS, S - RoW
Argon	Input	g	14.108	Market for Argon, liquid [argon, liquid] APOS,S - GLO
Electricity	Input	g	1.3613	Market for electricity, low voltage [electricity, low voltage] APOS, S - CO
NOx	Emission to air	g	0.8315	Nitrogen oxides, emission to air, unspecified
Chlorine	Emission to air	g	0.0085	Chlorine, emission to air, unspecified

2.8. Transport

Transport distances among the locations on the different stages of the life cycle were calculated by using Google maps. Oceanic distances were calculated by using free calculators in web sites, such as sea-distances.org. When transport distances were unknown, 100 km and 200 km by lorry and railway, respectively, were assumed according to the standard distances set by Hischer et al. [9]

3. Life Cycle Inventories

Tables 9–26 show the LCI for all the stages involved in the production of power from sugarcane press-mud. LCI were used to calculate the environmental impacts, as shown in the main manuscript.

Table 26Life cycle inventory for producing 1 g AuCuO/CeO₂.

Input	kind of flow	Unit	Value	Ecoinvent V3.4
Ce(NO ₃) ₃ ·6H ₂ O	Input	g	2.4725	Table 22
Cu(NO ₃) ₂ ·3H ₂ O	Input	g	0.0303	Table 23
HAuCl ₄ ·3H ₂ O	Input	g	0.2000	Table 24
Sodium hydroxide	Input	g	0.8940	Market for sodium hydroxide, without water, in 50% solution state sodium hydroxide without water, in 50% solution state APOS, S -GLO
Water tap deionized	Input	g	595.24	Market for water, deionized, from tap water, at user water deionized, from tap water, at user APOS, S - RoW
Rail train transport	Input	kg* km	0.0297	Market for transport, freight train Transport freight train APOS, S - Europe without Switzerland
Rail train transport	Input	Kg* km	6.5176	Market for transport, freight train transport freight train APOS,S-CN
Oceanic transport	Input	kg* km	75.161	Market for transport, freight, sea, transoceanic ship transport, freight, sea, transoceanic ship APOS, S -GLO
Freight transport	Input	kg* km	1.3022	Market for transport, freight, lorry, 3.5-7.5 metric ton, EURO 3 transport, freight, lorry 3.5 - 7.5 metric ton, EURO 3 APOS, S -GLO
Light commercial transport	Input	kg* km	0.0608	Market for transport, freight, light commercial vehicle transport, freight commercial vehicle APOS, S -GLO
Hydrogen	Input	g	0.0985	Market for hydrogen, liquid hydrogen, liquid APOS, S - RoW
Air	Input	m ³	0.0001	Market for compressed air, 600 kPa gauge compressed air, 600 kPa gauge APOS, S -GLO
Argon	Input	kg	44.885	Market for Argon, liquid argon, liquid APOS,S - GLO
Electricity	Input	kWh	4.1711	Market for electricity, low voltage electricity, low voltage APOS, S - CO
NOx	Emission to air	g	0.8776	Nitrogen oxides, emission to air, unspecified
Nitrogen dioxide	Emission to air	g	0.0116	Nitrogen dioxide, emission to air, unspecified
Oxygen	Emission to air	g	0.0032	Oxygen in air, emission to air, unspecified
Steam	Emission to air	g	2.6171	Water vapour, emission to air, unspecified
Sodium ions	Emission to water	g	1.3740	Sodium, emission to water, unspecified
Water	Emission to water	m ³	0.5932	Wastewater, m ³ , emission to water, unspecified
Chlorine ions	Emission to water	g	0.0036	Chlorine, emission to water, unspecified

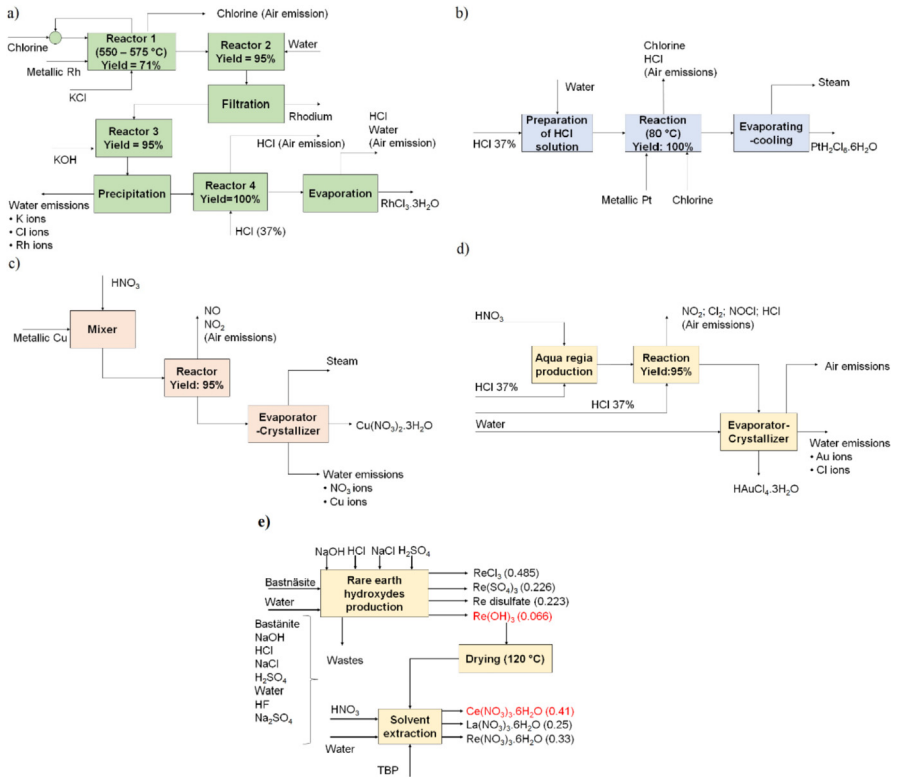

Fig. 8. Block flow diagram to produce a) RhCl₃·3H₂O; b) PtH₂Cl₆·6H₂O; c) Cu(NO₃)₂·3H₂O; d) HAuCl₄·3H₂O; e) Ce(NO₃)₃·6H₂O. Values in parenthesis are mass allocation factors.

Ethics Statement

Not applicable

CRediT Author Statement

Nestor Sanchez: Conceptualization, Methodology, Validation, Formal analysis, Writing – Original Draft, Visualization; **Ruth Ruiz:** Writing – Review & Editing, Visualization, Supervision, Formal analysis; **Anne Rödl:** Writing – Review & Editing, Visualization, Supervision, Formal analysis; **Martha Cobo:** Resources, Methodology, Writing – Review & Editing, Supervision, Project administration, Funding acquisition.

Declaration of Competing Interest

The authors declare that they have no known competing financial interests or personal relationships which have, or could be perceived to have, influenced the work reported in this article.

Data Availability

Dataset for the production of power from sugarcane press-mud (Original data) (Mendeley Data).

Acknowledgments

The authors are grateful to Minciencias (Francisco Jose de Caldas Fund) and Universidad de La Sabana for the financial support of this work through the project ING-221 (Minciencias contract 548-2019). Nestor Sanchez acknowledge Minciencias for the Doctoral scholarship (727-2015) and Hamburg University of Technology (TUHH) for the opportunity to do his research stay.

References

- [1] N. Sanchez, R. Ruiz, A. Rödl, M. Cobo, *Renew. Energy* (2021) 104743.
- [2] N. Sanchez, R.Y. Ruiz, B. Cifuentes, M. Cobo, *Waste Manag.* 98 (2019) 1–13.
- [3] J.B. Dunn, S. Mueller, M. Wang, J. Han, *Biotechnol. Lett.* 34 (2012) 2259–2263.
- [4] P. Bastidas, J. Parra, I. Gil, G. Rodríguez, *Procedia Eng.* 42 (2012) 80–89.
- [5] B. Cifuentes, F. Bustamante, D.G. Araiza, G. Diaz, M. Cobo, *Applied Catal. A, Gen.* (2020) 117568.
- [6] F. Battista, Y.S. Montenegro Camacho, S. Hernández, S. Bensaïd, A. Herrmann, H. Krause, D. Trimis, D. Fino, *Int. J. Hydrogen Energy* 42 (2017) 14030–14043.
- [7] S. Achinas, G. Jan, W. Euverink, *Resour. Technol.* 2 (2016) 143–147.
- [8] XM, (2020).
- [9] R. Hischer, S. Hellweg, C. Capello, A. Primas, *Int. J.* 10 (2005) 59–67.
- [10] J. Kleinberg, *Inorganic Syntheses VII* (1963).
- [11] H. Renner, G. Schlamp, I. Kleinwächter, E. Drost, H.M. Lüscho, P. Tews, M. Diehl, J. Lang, T. Kreuzer, A. Knödler, K.A. Starz, K. Dermann, J. Rothaut, R. Drieselmann, C. Peter, R. Schiele, J. Coombes, M. Hosford, D.F. Lupton, *Ullmann's Encycl. Ind. Chem.* (2018) 73.
- [12] J. Zhang, H.W. Richardson, *Ullmann's Encycl. Ind. Chem.* (2000) 31.
- [13] L. Talens Peiró, G. Villalba Méndez, *Jom* 65 (2013) 1327–1340.
- [14] S. Gross, U. Schubert, N. Hüsing, R.M. Laine (Eds.), *Mater. Synth. A Pract. Guid.*, SpringerWienNewYork (2008) 155–158.
- [15] N. Sanchez, M. Cobo, *Mendeley Dataset* (2020), doi:10.17632/5nhfjhh778.2.
- [16] S. Authayanun, P. Aunsup, Y. Patcharavorachot, A. Arpornwichanop, *Energy Convers. Manag.* 86 (2014) 60–69.