

# ULTRASTRUCTURAL LOCALIZATION OF MINERAL MATTER IN BACTERIAL SPORES BY MICROINCINERATION

RICHARD S. THOMAS, Ph.D.

From Western Regional Research Laboratory, United States Department of Agriculture, Albany, California

## ABSTRACT

The fine localization of mineral matter in spores of *Bacillus megaterium* and *Bacillus cereus* was studied by the technique of microincineration adapted for use with the electron microscope. The specimens, which included intact and thin-sectioned spores as well as shed spore coats, were burned either in the conventional way at high temperature or by a new technique using electrically excited oxygen at nearly room temperature. The ash residues were examined by bright field, dark field, and diffraction in the electron microscope and also with the phase contrast microscope. In some cases, the specimen was previewed in both microscopes before incineration. The results do not support a previous report that the mineral elements of the spore are confined to a peripheral layer, but rather indicate that the spore core as well as the coat are mineral-rich. The cortex may be deficient in minerals, but the possibility of artifact prevents a clear decision on this point. Incinerated *B. megaterium* spores show a highly ordered fine structure displaying 100 Å periodicity in the ash of the middle layer of the coat. The nature of this structure is discussed, as is the technique which demonstrated it. The fine definition of the ash patterns, particularly those obtained with the low-temperature, excited-oxygen technique, suggests that microincineration may be generally useful in the study of fine structure.

## INTRODUCTION

Bacterial spores contain metals and other mineral elements in quite appreciable amounts; in spores of *Bacillus megaterium*, for example, the incombustible residue is 11 to 12 per cent of the dry weight (39). The major mineral constituents are potassium, calcium, manganese, magnesium, copper, and phosphorus, with calcium frequently the most abundant (6, 22). Numerous studies have shown that the minerals play an important role not only in the development of the spore, but also in its unique tolerance to high temperatures. Manganese seems to be an absolute nutritional requirement

for spore formation (5, 35), while calcium is highly correlated with the spore's heat resistance (1, 15, 35, 37).

These considerations lead one to ask in what structures—*e.g.* coat, cortex, or core—of the spore the mineral elements are localized. Most of the evidence on this question is circumstantial. For example, Mayall and Robinow (23) showed that the cortex disappears during early germination at the same time that most of the calcium is released into the medium (27). They thus speculate that calcium is localized in the cortex. Consistent with

this idea, calcium is incorporated into the developing spore during the time that the cortex is forming (48).

There is also some evidence on mineral localization from analysis of isolated spore coats. This includes figures for total ash (4, 36, 47), phosphorus (11, 32, 36, 43, 47), calcium (21), magnesium (21) and manganese (21, 46) content. The results are difficult to evaluate, however, owing to the probable morphological heterogeneity of the preparations, and possible losses of mineral.

A third kind of evidence was recently provided by Knaysi (17, 18) who applied the technique of microincineration (16, 25, 34). This long established method (first applied to bacterial spores in 1932 by Scott (33)) consists simply of burning the specimen on a microscope slide to remove all organic material, and then examining the pattern of ash which remains. The technique cannot localize individual metallic elements, but it can indicate whether a particular structure is rich or poor in mineral elements as a whole.

Knaysi observed a ring-like residue of ash from the spores and concluded that the mineral elements must be largely concentrated in a peripheral layer, perhaps the cortex, surrounding a mineral poor core. His observations, however, were severely limited by the resolving power of the phase contrast microscope. It seemed desirable, therefore, to repeat and extend this work using the electron microscope.

There have been a few previous reports of microincineration used with this instrument (8, 9, 26, 42, 45). To adapt the classical technique requires only that a suitably thin, heat-resistant specimen support be found. Thin films of aluminum and beryllium (9) or silicon monoxide on stainless steel grids (45) have been used successfully. Alternately, a thin film replica can be made of the ash deposit on a glass slide (26).

The electron microscope specimen has usually been burned by high temperature, either in a furnace (26, 45) or by the electron beam within the microscope (8). Turkevich and Streznewsky, however, carried out the incineration at room temperature with a stream of electrically excited oxygen (42). Their specimens were simply carbon particles, but Turkevich suggested using the same technique on biological material (41). Independently, a similar excited oxygen technique for ashing larger carbonaceous specimens was developed by Gleit and Holland (13, 14).

The present investigation used both high-temperature ashing and low-temperature, excited oxygen incineration following Gleit and Holland. The techniques were applied to intact, whole spores, as used by Knaysi, and also to thin-sectioned spores and germinated spore coats. The latter two preparations could not give reliable information on the over-all distribution of total mineral in spores, since they undoubtedly lost some material during processing, but they could show in more detail the fine localization of structure-bound minerals which were retained. *Bacillus megaterium* spores were used for most of the experiments, but, to allow direct comparison with Knaysi's results, spores of *Bacillus cereus* were also employed.

The work has been concerned with exploration of the technique as well as with the structure of spores, and is still in its initial phase. Results obtained so far seem to justify publication at this time, however. A brief, preliminary account of some of this work has been published elsewhere (38).

## MATERIALS AND METHODS

### *Devices for Incineration*

High-temperature incineration was performed either in an electrically heated muffle furnace or on a simple heating stage in a Kinney SC-3 vacuum evaporator. The heating stage permitted more flexible temperature control than the furnace and also allowed specimens to be heated under vacuum.

For accurate determination of specimen temperature in the muffle furnace, a stainless steel block with a thermocouple junction embedded in it was placed on the floor of the furnace, and the electron microscope specimen grids, or milligram samples of spores, were placed in a small crucible resting directly on the block.

The vacuum evaporator heating stage consisted of a platinum ribbon 0.13 x 6 x 54 mm, mounted horizontally in the standard filament holders (see Fig. 1). A thermocouple junction of 28-gauge chromel and alumel wires was spot welded to the under surface at the center of the ribbon. The specimen grid was placed on the upper surface directly over the junction. The thermocouple was calibrated by the melting points of various salts, a few crystals of which were placed on the ribbon in place of the specimen grid.

Low-temperature, excited-oxygen incineration was carried out in a prototype version of the Tracerlab Low Temperature Asher, model LTA 500, described by Gleit and Holland (13, 14). The device consists essentially of a glass tube through which passes a

stream of oxygen at a pressure of about 1 mm and a flow rate of 50 cc/minute (S.T.P.). At the upstream end, a coil surrounding the tube imposes a high voltage, radio frequency electromagnetic field on the gas, producing an electrodeless ring discharge. This is seen as a purple glow, which extends a considerable distance downstream from the coil. The specimen to be incinerated is placed in the glow at the downstream end of the tube where the temperature is only slightly above ambient.

The atomic oxygen and other metastable species formed by the discharge have sufficient energy to completely oxidize all organic compounds (14) but the reaction rate is found to vary greatly with different kinds of specimen. Surface-to-volume ratio

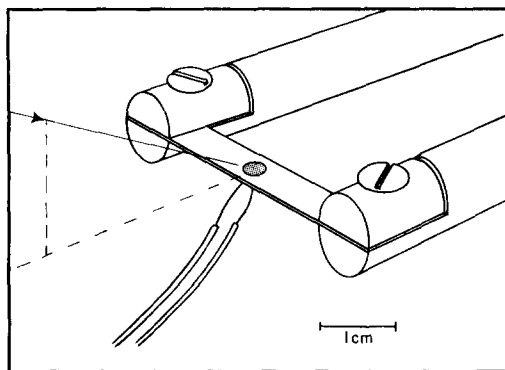

FIGURE 1 Heating stage in vacuum evaporator. The specimen grid is seen on the platinum ribbon filament directly over the thermocouple junction. The arrow indicates the direction of shadowing.

seems to be the most important factor. The diffusion of oxygen into the specimen is much slower than for high-temperature incineration, and an insulating layer of ash forming on the surface can greatly hinder the oxidation. The procedure is thus best suited to very thin or porous objects.

### Specimen Grids

For high-temperature incineration, 200-mesh grids of either gold or stainless steel were used. Gold grids worked well with the platinum heating stage, since at high temperatures they would adhere to the platinum surface, insuring good thermal contact. For low-temperature incineration, the grids were 200-mesh titanium (EFA-Ti) or stainless steel. Gold grids could not be used for low-temperature incineration, since catalyzed recombination of atomic oxygen at their surfaces heated the grids to high temperatures.

The grids were filmed with silicon monoxide. This was vacuum evaporated onto grids covered with

collodion and the latter was burned away in either the muffle furnace or the excited oxygen device. The films were estimated to be about 200 Å thick.

In some initial experiments (38), a thin film of carbon was deposited on the silicon monoxide to prevent possible reaction of specimen ash materials with the latter. This was not necessary, however.

### Whole Spore Preparations

Spores of *B. megaterium*, strain Northern Regional Research Laboratory B-938, and *B. cereus*, strain T

TABLE I  
Mineral Elements in *B. megaterium* Spores

Mineral element	Amount (% native spore dry wt)*		
	Lot GA com 8-62	Lot GA 8-22-61	
	(Native)	(Native)	(Formalin-fixed)
Potassium	—	3.4	0.8
Calcium	2.0	2.6	2.5
Manganese ‡	1.4	1.6	1.4
Phosphorus	1.4	1.5	1.4
Magnesium	0.28	0.24	0.24
Sodium	—	~0.1	(undetectable)
Copper	0.02	0.04	~0.005
Iron	0.03	0.01	0.01

\* Potassium and sodium were determined by flame photometry (7). The emission spectrograph was used for calcium, manganese, copper, and iron (22). Phosphorus was determined colorimetrically (2).

‡ The spores, intended for other studies (46), were grown in a manganese-enriched medium which raised their content of this element.

were grown and purified as described by Alderton and Snell (1), and Sacks and Bailey (31), respectively. The dry spore powders were stored in closed containers in the refrigerator until used.

An analysis of the mineral elements present in the *B. megaterium* spores is shown in Table I.

For whole mount preparations, the spore powder was suspended (Potter homogenizer) in distilled water and sprayed onto the electron microscope grids. Examination of both the suspension and the grids under phase contrast showed that nearly all spores were normally refractile.

### Germinated Spore Coats

Coats from germinated spores were present as a minor contaminant in the whole spore preparation of *B. megaterium*. Apparently, they originated in the culture and were carried with the whole spores

through the polymer-two phase system used for purification (30).

### *Thin-Sectioned Spores*

Lyophilized spore powder was suspended in 55 per cent neutralized (with  $\text{NH}_4\text{OH}$ ) formalin at  $40^\circ\text{C}$  for 65 hours, with occasional agitation. The spores were then washed in distilled water and pelleted in 10 per cent gelatin in a disposable polyethylene centrifuge tube. After chilling the tube, the tip was cut off to liberate the undisturbed pellet, which was dehydrated by a graded series of ethanol-water, ethanol, and ethanol-methacrylate mixtures. The aqueous reagents were chilled to prevent disintegration of the pellet. Embedding was in 30 per cent methyl-, 70 per cent butyl-methacrylate containing 1 per cent  $\alpha, \alpha'$ -azodiisobutyronitrile (AIB) as catalyst (44). Polymerization was effected by ultraviolet illumination at room temperature. Sections, cut (Porter-Blum microtome, diamond knife) onto a water surface and spread with toluene vapor, ranged in color from grey to light gold. After collecting them on specimen grids, the methacrylate was usually removed by immersing the grids in benzene for 3 to 5 minutes.

Some features of the procedure deserve special comment. The spores proved rather difficult to fix with formalin, hence the high concentration of formalin, elevated temperature, and extended time reported here. Results obtained thereby seemed superior to those of less extreme conditions.

Methacrylate was used as embedding medium because it was easily removed from the sections (to prevent possible complications during the incineration)

and *because* it gave rise to an explosion artifact. As will be seen below, this was advantageous in resolving the structures of the spore coat. The formalin-fixed spores were prone to extreme explosion, but this was controlled by the use of AIB as catalyst and by maintaining tight packing of the spores in the gelatin pellet.

The over-all procedure did not preserve intact the total mineral content of the spores, as shown in a preliminary way by analysis at the first step, formalin fixation (see Table I). Although many of the minerals were retained, potassium, sodium, and copper were largely lost. It seems likely that further losses occurred in the dehydration, embedding, and sectioning onto the water surface, but their extent is not yet known.

### *Optical and Electron Microscopy*

For phase contrast observations, a Tiyoda microscope equipped with a 40x,  $\text{NA}$  0.65, phase N.D.L. objective, and 20x oculars was used. Over-all magnification was 1200. Unfiltered Koehler illumination was provided by a tungsten ribbon filament lamp. Electron microscope specimen grids were mounted in air under a coverglass.

Electron microscopic observations were made with an Hitachi HU-10, using a  $35\text{-}\mu$  objective aperture, and operating at 50 kv. Micrographs were taken at magnifications ranging from 2700 to 27,000, with exact magnification determined by reference to standard,  $0.264\text{-}\mu$  polystyrene particles. Specimens were shadowed with uranium at incident angle  $\arctan 1/2$ . The local shadow angle was somewhat indeterminate, however, owing to undulations in the specimen support film.

---

FIGURE 2 Unincinerated control preparation of whole *B. megaterium* spores. Air-dried, sprayed with  $0.264\text{-}\mu$  polystyrene reference particles, and uranium shadowed. Note that the spores were little, if at all, flattened during drying. The flattened object is part of a germinated spore coat.  $\times 8,000$ .

FIGURE 3 *B. megaterium* preparation, similar to that of Fig. 2, after 30 minutes at  $500^\circ\text{C}$ . Uranium shadowed after incineration. Typical assortment of ash residues. Note that the central mass in each case stands well up off the support film. The surrounding pattern of small granules suggests a collapsed membrane in some cases.  $\times 18,000$ .

FIGURE 4 Unincinerated control preparation of whole *B. cereus* spores. Details of preparation similar to that of Fig. 2. Note the collapsed exosporium surrounding the spore body.  $\times 18,000$ .

FIGURE 5 *B. cereus* preparation, similar to that of Fig. 4, after 30 minutes at  $500^\circ\text{C}$ . Uranium shadowed after incineration. Typical assortment of ash residues all taken from the same plate; the images were cut apart and reassembled to save space. In addition to the ash of the spore body, note a surrounding, very faint pattern of fine ash granules from the exosporium.  $\times 18,000$ .

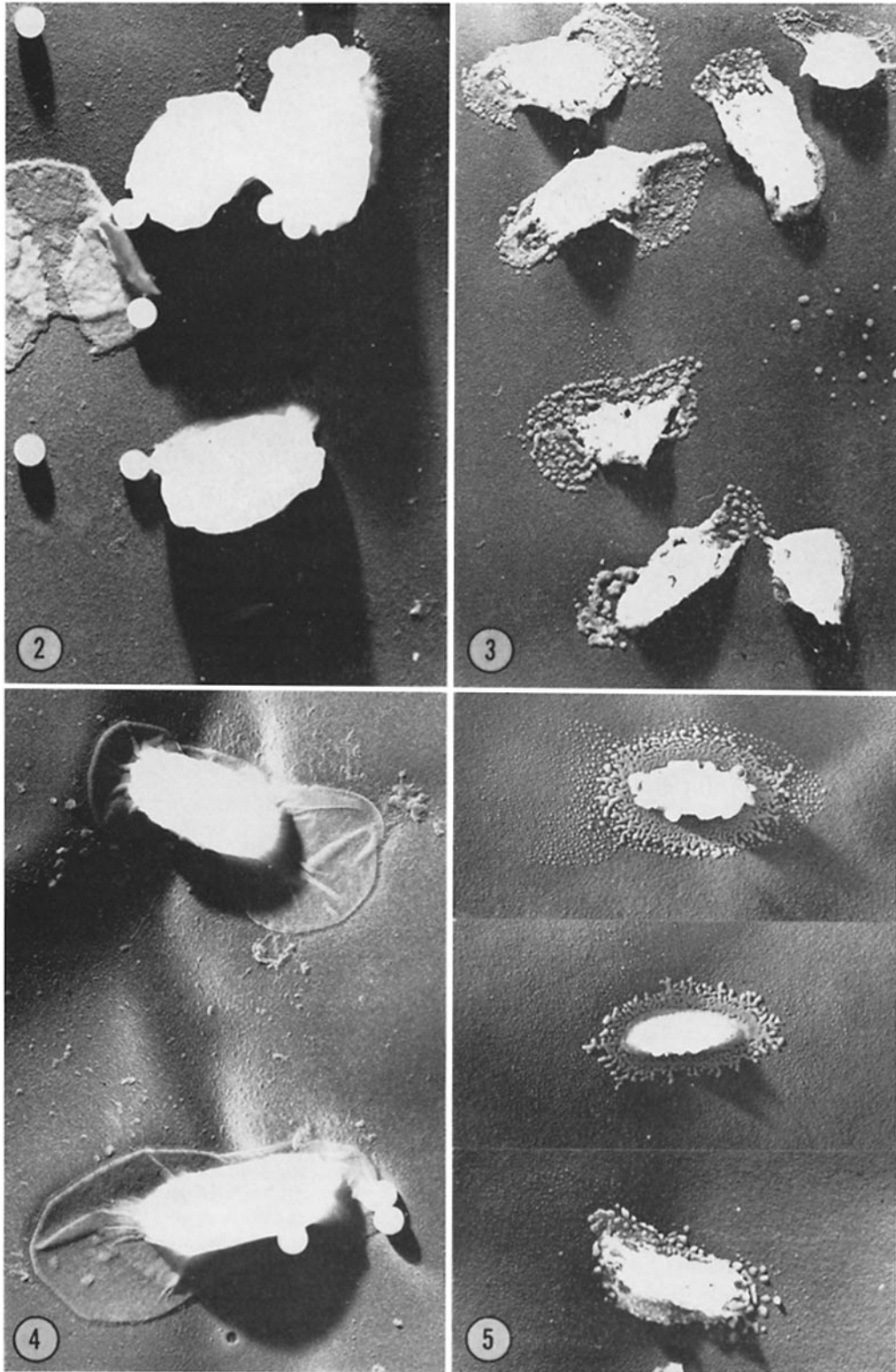

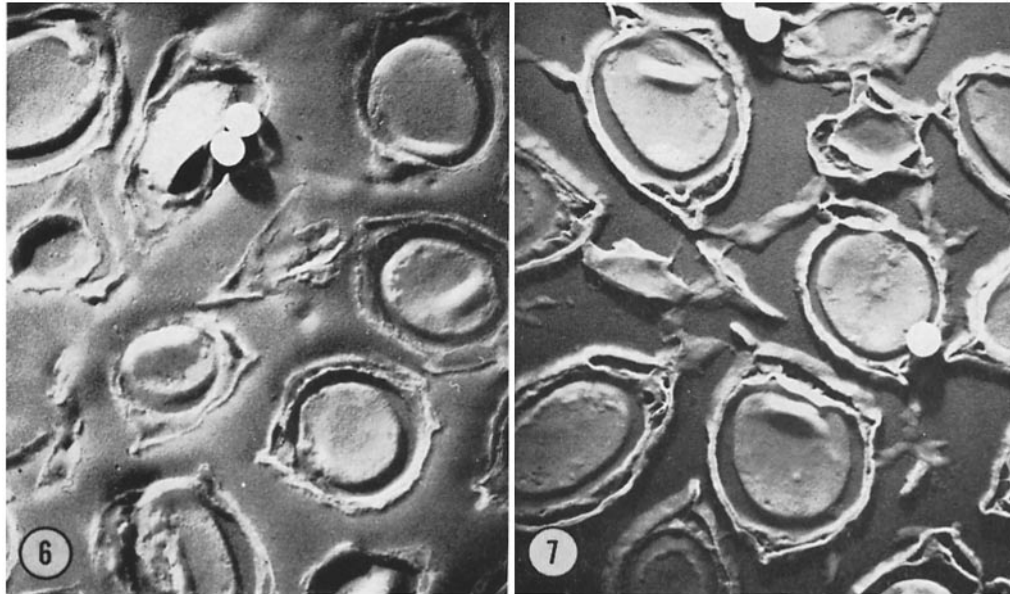

FIGURE 6 Thin section of formalin-fixed, methacrylate-embedded *B. megaterium* spores. Embedment retained. Sprayed with 0.264- $\mu$  polystyrene reference particles and uranium shadowed. Note that the cortical region of each spore is represented simply by a hole in the section.  $\times 18,000$ .

FIGURE 7 Thin-sectioned *B. megaterium* spore preparation similar to that of Fig. 6, but with methacrylate removed. Note that the spore coat has been dissected into two or three layers by the methacrylate explosion artifact.  $\times 18,000$ .

## EXPERIMENTS AND RESULTS

### *High-Temperature Incineration of Whole Spores*

Initial experiments were performed approximately as described by Knaysi (18) so that results could be directly compared.

Spores mounted on the grid were fixed by aqueous formaldehyde vapor for a few minutes. The grid was placed on the heating stage and the temperature gradually raised, over the course of a few minutes, to 500°C, where it was maintained for 30 minutes. After cooling and evacuation of the chamber, the grid was then shadowed with

FIGURE 8 Thin-sectioned *B. megaterium* spore preparation with methacrylate removed, similar to that of Fig. 7, but without shadowing (and without contrast reversal). Again note that the spore coats have been split into layers. Note also that in several cases the spore core was poorly cut by the knife and the core cross-section is displaced and relatively thick.  $\times 16,000$ .

FIGURE 9 The same preparation, same field of view as that of Fig. 8, but after incineration at 600°C for 30 minutes. Uranium shadowed after incineration. The spore core is, in each case, represented by a pattern of droplet-shaped ash granules. Note, however, that the coarseness or fineness of this pattern correlates with the original thickness of the core cross-section and, in two instances, the core ash consists mainly of a single large droplet. The coat is usually represented by a well defined ash pattern which varies somewhat from spore to spore. In some cases, it consists of a well defined broad belt of ash; in others, of a thin broken line of ash, or both the thin line and the belt. The details of the coat ash pattern and their correspondence to the original coat structures are more easily seen in Figs. 10 and 11.  $\times 16,000$ .

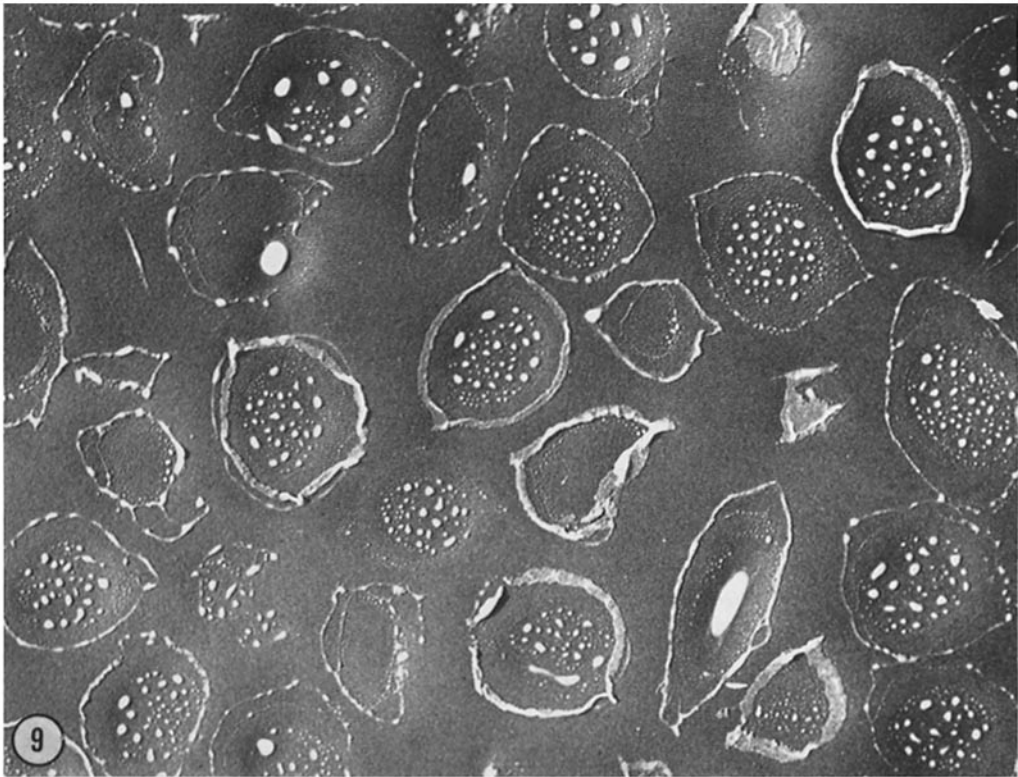
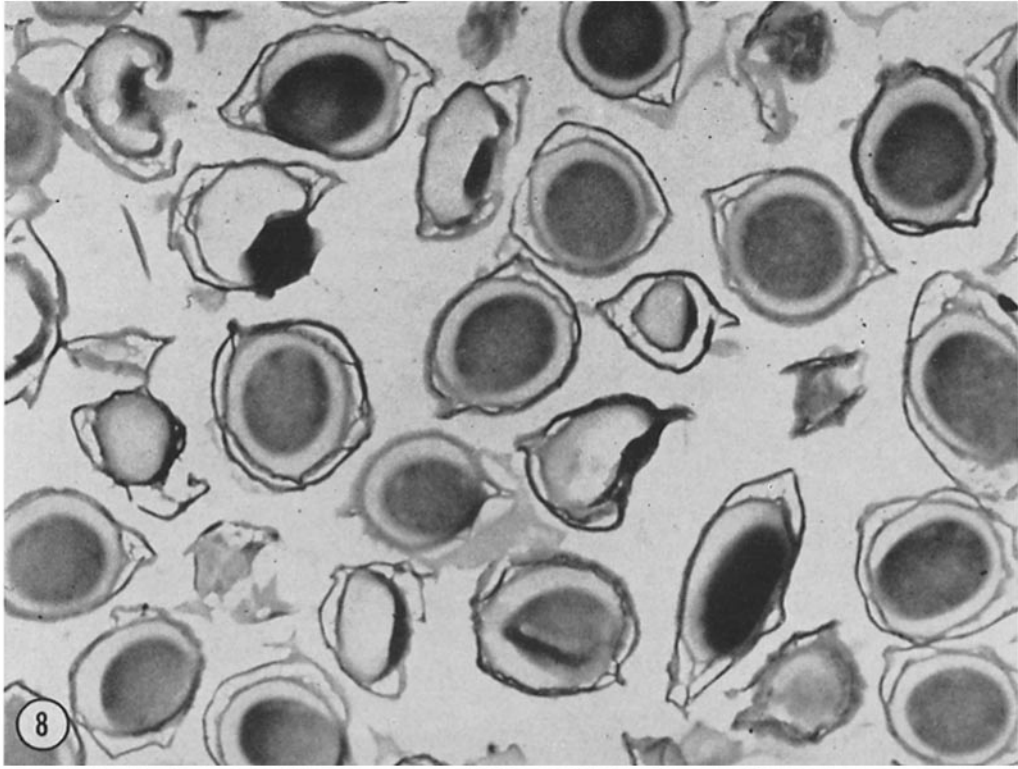

uranium. In some cases, the grid was maintained above 150°C until high vacuum was reached, to eliminate possible moisture uptake (16, 20, 34) before the ash was stabilized by shadowing. This precaution seemed to be unnecessary, however.

Grids of spores were also incinerated at 600°C for 30 minutes in the muffle furnace and without formalin fixation or gradual rise to temperature. The higher temperature has been recommended to insure complete removal of carbon (16, 34). The appearance of the ash was not significantly different than after 500° incineration, however.

Figs. 2 to 5 show electron micrographs of the ash residues of *B. megaterium* and *B. cereus* spores after 500° treatment together with unincinerated control preparations.

Typically, the ash of *B. megaterium* spores appeared as a rather amorphous, three-dimensional mass, surrounded by a flat pattern of granules. The cinder-like central mass was usually one-half to two-thirds the dimensions of the spore before incineration. The flat pattern was variable, but often had nearly the same size as the intact spore profile. There was no clear correspondence between the ash and any structure known in the intact spore. The flat pattern of granules, however, frequently resembled a collapsed membrane. Taken with results presented below, this suggests that it may have derived from the outer coat of the spore.

*B. cereus* spores gave similar ash residues except that there was usually a barely detectable array of fine granules lying around the main pattern of ash. This clearly corresponded to the exosporium which was seen collapsed around the spore body before incineration.

None of the ash residues were ring-like as reported by Knaysi (17, 18). However, when the same incinerated spores were examined in the phase contrast microscope, the apparent objects were very similar to those seen in his micrographs. They were of two kinds: uniformly dark, circular or oblong particles of diameter about one-half that of untreated spores, and similar objects, usually slightly larger, which had luminous centers of varying size. The centers were occasionally either brighter or more bluish than the background and thus could be recognized as a refraction effect similar to that seen in the images of untreated spores. Without these optical clues and prior knowledge from the electron microscope, however, the luminous centers might well have been

mistaken for an absence of material, and these ash residues would then have seemed ring-like.

### *High-Temperature Incineration of Thin-Sectioned Spores*

(A) THE NATURE OF THE SECTIONS BEFORE INCINERATION: Figs. 6 and 7 show typical shadowed thin sections of formalin-fixed *B. megaterium* spores, with and without the embedding methacrylate removed. Most of the spore cross-sections showed considerable or total loss of material from the cortex. Apparently, this region was neither fixed by formalin nor infiltrated by methacrylate, and dissolved away when the sections were floated on water. Any minerals here were presumably lost, to a large extent. It should also be noted that "unbound" minerals may have been lost from elsewhere in the section even though the structure stayed intact.

The spore core seemed fairly well preserved, morphologically, as was the coat. The latter structure, however, was distended and split into two or three distinguishable layers by the methacrylate explosion.

(B) EXAMINATION OF THE SAME SECTION BEFORE AND AFTER INCINERATION: Figs. 8 and 10 show thin sections of *B. megaterium* spores with methacrylate removed, but without shadowing. The three layers of the coat are clearly distinguished in Fig. 10.

These fields of view were located on the grid so that they could be re-examined after incineration, and then the grid was gradually brought to 600°C on the heating stage and maintained for 30 minutes. Two precautions were observed: (1) To eliminate possible formation of refractory intermediate oxidation products (33), air was admitted only after reaching maximum temperature; (2) The grid was kept hot after ashing until the chamber was evacuated, to eliminate possible moisture uptake before shadowing. Further experience indicated that neither safeguard was important, however.

A control grid, similarly treated but without prior viewing, showed that exposure to the electron beam had no effect on the quality of the subsequent ash pattern.

Figs. 9 and 11 show the same fields as Figs. 8 and 10, after incineration and shadowing. The correspondence of the ash patterns to the original spore sections was striking. In particular, a pattern of droplet-shaped ash particles corresponded ac-



curately, in most cases, to the area of the core before incineration, and outside that, a belt or ridge corresponded closely to the coat. Between those two structures, in the region of the cortex, there was little or no ash. This is not unexpected however, since, as shown above, the sections were devoid of cortical material before incineration.

The residue of the multilayered coat emerged as the most interesting feature (see Figs. 10 and 11). The inner layer of the coat yielded essentially no ash, and the outer layer, densest before incineration, yielded only a relatively small amount. The middle layer, on the other hand, gave a prominent and well defined belt of ash which corresponded closely to the configuration of the middle layer before incineration. Where this layer had collapsed onto the support film and could be seen face on, a hint of fine structure was evident in the ash. This will be considered in more detail below.

Many of the spore cross-sections did not show this middle layer ash residue (see Figs. 8 and 9). The proportion which did varied from one embedded block to another, suggesting that heterogeneity with respect to this structure may have resulted from variable losses of mineral during processing.

(C) EFFECT OF SECTION THICKNESS ON DEFINITION OF THE ASH PATTERN: In comparing Figs. 8 and 9, one will note that size and distribution of the ash particles, particularly in the region of the spore core, depended on section thickness. Where the core was thick, the ash "pattern" was a single large droplet. Fig. 12 shows a very thin section from the same grid. The droplet pattern here had a very fine texture and corresponded precisely to the contours of the core. Variations in pattern texture within the core were reminiscent of the distribution of chromatin (29) and may be significant. Because of this coalescence of the ash into droplets, satisfactory ash patterns could not be obtained from sections thicker than about 70  $\mu$ . The phenomenon undoubtedly contributed to the amorphous appearance of the ash of whole spores.

(D) EFFECT OF INCINERATION TIME ON DEFINITION OF THE ASH PATTERN: Grids of *B. megaterium* spore sections were incinerated at 600°C for times shorter than 30 minutes to see if this might improve the structural detail of the ash patterns.

In one such experiment, a grid placed on the

heating stage was brought up to 600°C in air over the course of 2 minutes, maintained for 10 minutes, rapidly cooled to room temperature in air, and shadowed. Alternately, grids were simply placed directly into the preheated muffle furnace at 600°C, removed 10 minutes later, and shadowed.

Fig. 13 shows results typical of either procedure. The ash pattern was not grossly different than after longer treatment, but now the ash of the coat middle layer, when present, showed remarkable fine structure. Minute fibrils were seen lying parallel to one another in regular arrays with periodic spacing of about 100 Å. The arrays had various orientations in different parts of the middle layer, and in transitional regions contiguous arrays sometimes appeared superimposed.

The fine structure was displayed less clearly in some ash patterns than others, but nevertheless was always discernible in the middle layer. To see if it might be evident without incineration, de-embedded, shadowed, or unshadowed cross-sections showing the middle layer were examined closely. No indication of the structure could be detected.

(E) EFFECT OF INCINERATION TIME ON THE COMPLETENESS OF ASHING: CHEMICAL AND MICROSCOPIC EVIDENCE: It seemed likely that 10 minutes at 600° was sufficient to completely ash the thin sections, but, to be certain on this point, a few control experiments were conducted with milligram amounts of *B. megaterium* spore powder.

Weighed samples were heated for varying lengths of time at 600°C in the muffle furnace, reweighed, treated with cold 6 N hydrochloric acid to drive off any carbonate present, and then analyzed for carbon (24).

The results of two experiments are shown in Table II. The samples reached constant weight in 10 minutes or less, and, when treated with acid, they dissolved almost completely. A very slight black residue remained, however, and its visually estimated quantity correlated with the trace amount of residual carbon found. Phase contrast examination of the residue showed small clusters of refractile particles which looked like spores but appeared black under low power, brightfield illumination.

It seemed likely that this residue represented a few incompletely burned spores shielded in the center of aggregates rather than an unburned

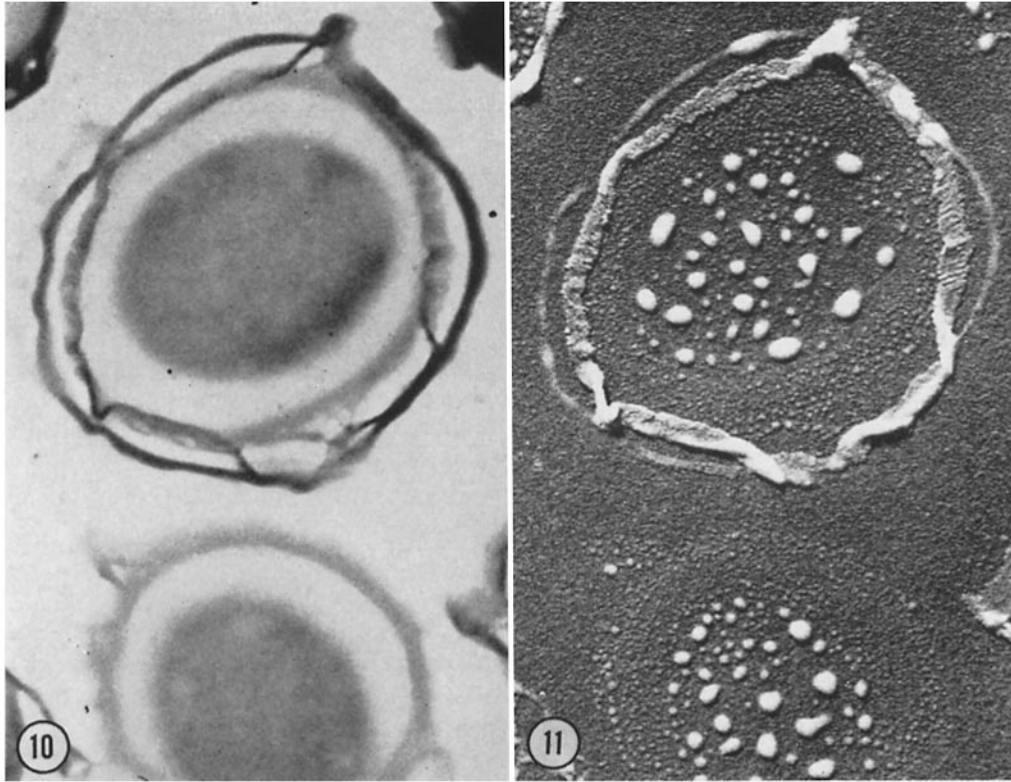

FIGURE 10 Two selected spore cross-sections from the field of Fig. 8. In the upper spore, note that the coat is split into three layers: a somewhat diffuse inner layer bordering the empty cortical space; a dense, outermost layer; and a membranous middle layer which is contiguous in different places with either the inner or outer layer. In the lower spore, the middle and outer coat layers have been lost.  $\times 43,000$ .

FIGURE 11 The same preparation, same field of view as that of Fig. 8, after incineration at  $600^{\circ}\text{C}$  for 30 minutes, and then uranium shadowed. Note that in both spore cross-sections the inner layer of the coat left almost no ash. In the upper spore, note that a thin line of ash corresponds to the formerly dense outer layer of the coat; the well defined and more prominent ash belt corresponds to the membranous middle layer. At several places on this belt, there appear striations which are suggestive of fibrillar fine structure.  $\times 43,000$ .

---

FIGURE 12 Incinerated preparation similar to that of Fig. 9, found on the same grid. A thinner section. Note that the ash pattern of the spore core consists of smaller droplets more closely spaced, thus giving a finer texture and definition to the pattern. Variations in the texture in different areas of the core are apparent. The belt of ash representing the middle layer of the coat is narrower on the average; its width can be taken as an indication of the section thickness.  $\times 16,000$ .

FIGURE 13 Incinerated *B. megaterium* spore cross-section. Preparation similar to those shown in Figs. 9, 11, and 12, except that incineration time at  $600^{\circ}\text{C}$  was reduced from 30 minutes to 10 minutes. Note that the ash of the coat middle layer clearly shows detailed fine structure. The periodic spacing in the oriented fibrillar arrays of the structure is about 100 A. Note that the orientation of the arrays varies in different regions and that at the boundary between two arrays both orientations can sometimes be seen overlapping.  $\times 70,000$ .

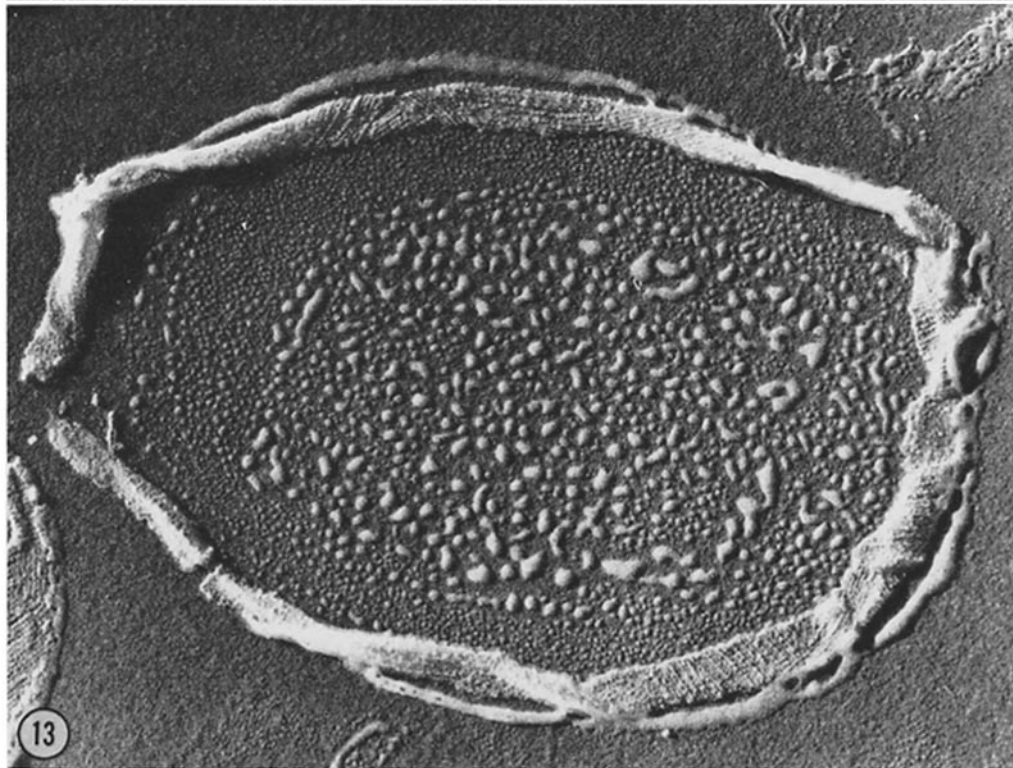
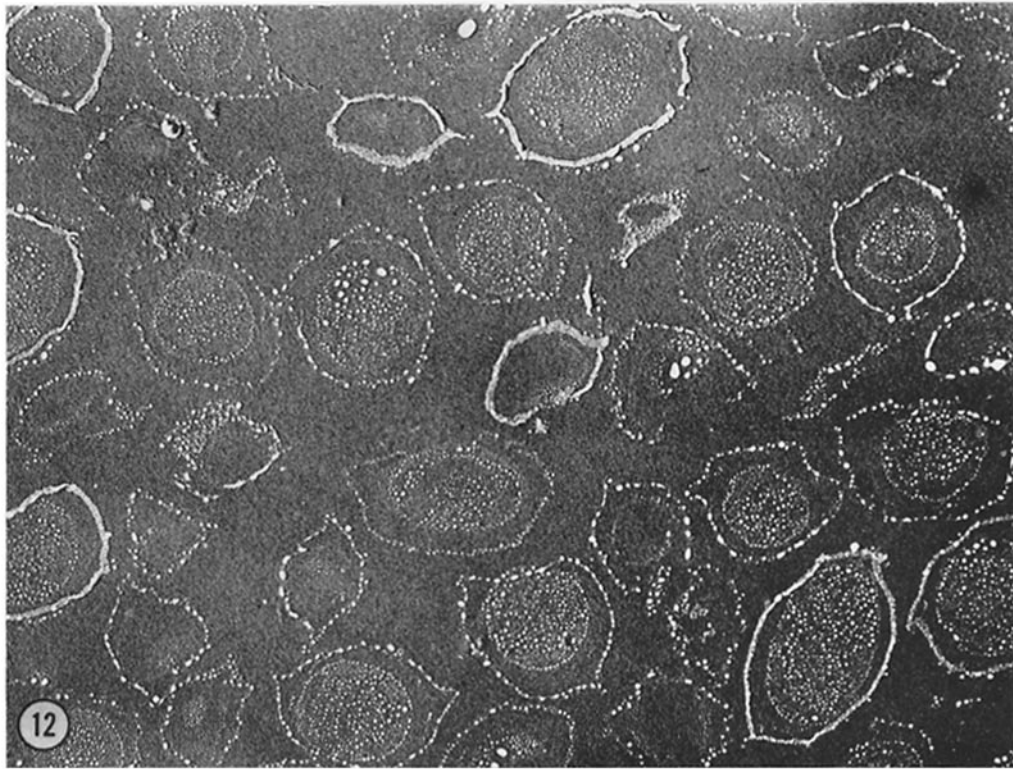

fraction of all the spores. To test this hypothesis, aggregate-free smears of spores on Vycor slides were heated in the furnace at 600° for varying lengths of time, as before, and then examined under the microscope after acid treatment. No insoluble particles remained if the preparation had been heated for 90 seconds or more.

TABLE II  
Total Ash and Residual Carbon of *B. Megaterium*  
Spores (Lot GA com 8-62) after Incineration  
at 600°C

Sample No.	Initial wt (mg)	Time at 600°C (min)	Ash wt		Carbon wt Initial wt
			Initial wt	Acid-insoluble residue*	
1	29.49	10	0.1146	+++	0.0005
2	28.43	30	0.1150		
		90	0.1150	++	0.0002

\* Visual estimate.

It seems safe to conclude that thin sections were totally ashed in much less than 10 minutes.

*Low-Temperature, Excited-Oxygen Incineration of Thin-Sectioned Spores, Spore Coats, and Whole Spores*

(A) CRITERION FOR COMPLETE ASHING OF SPECIMENS AND PROCEDURE: Low-tem-

perature incineration was entirely empirical, and so it again became necessary to have an experimental criterion for complete ashing of the electron microscope specimens. Carbon analysis of milligram test samples suggested itself, as before, but this now proved inapplicable. Owing to the poor penetration of low-temperature, excited oxygen, many hours' treatment was required for ashing milligram amounts of spores, and in this time the ash patterns of thin sections showed clear evidence of overtreatment. Small, needle-like crystals were sometimes seen growing out of the ash structure. Previous experiments indicated that totally combusted spores were entirely soluble in cold 6 N acid, however, and so this solubility criterion was applied, using as a test object thin smears of spores on microscope slides which were rapidly attacked by the excited oxygen.

A test smear was always included in the ashing experiment, with the electron microscope grid placed directly on the same slide in the incineration chamber. The instrument was operated at the lowest power setting, and power input was sometimes further reduced by detuning. Complete ashing, as judged by solubility of the test smear, took 3 to 10 minutes, depending on the power input. The grids were transferred without delay from the ashing chamber to the vacuum evaporator and shadowed.

FIGURE 14 Thin-sectioned *B. megaterium* spore preparation, from which the methacrylate was removed, and which was then incinerated at low temperature by electrically excited oxygen. Uranium shadowed. Low magnification survey picture of typical field.  $\times 16,000$ .

FIGURE 15 Preparation identical to that of Fig. 14. Higher magnification view of a selected spore cross-section to show typical detail in the ash pattern. Note that where the ashed middle layer of the coat has collapsed onto the support film, it shows the 100-A fibrillar fine structure. Otherwise, however, note that this layer and the ashed outer layer stand neatly erect off the support film. Note also that the ash of the core has a granulated, reticular texture.  $\times 50,000$ .

FIGURE 16 Low-temperature incinerated preparation similar to that of Figs. 14 and 15, but thicker section. Methacrylate was not removed before incineration. Note that in the spore cross-section partly in the field (to the left) a part of the coat ash is not in contact with the support film. In the uppermost spore cross-section, the ash reticulum of the core looks condensed and is rather small in diameter, suggesting that it may have contracted during the incineration process.  $\times 36,000$ .

FIGURE 17 Low-temperature incinerated spore cross-section found on the same grid, nearby those of Fig. 16. The spore was apparently cut nearly tangentially and the section included only the coat layers. The ashed middle layer is easily recognized by its 100-A fibrillar texture. Note that the overlying, outer layer ash has a meshwork texture.  $\times 70,000$ .

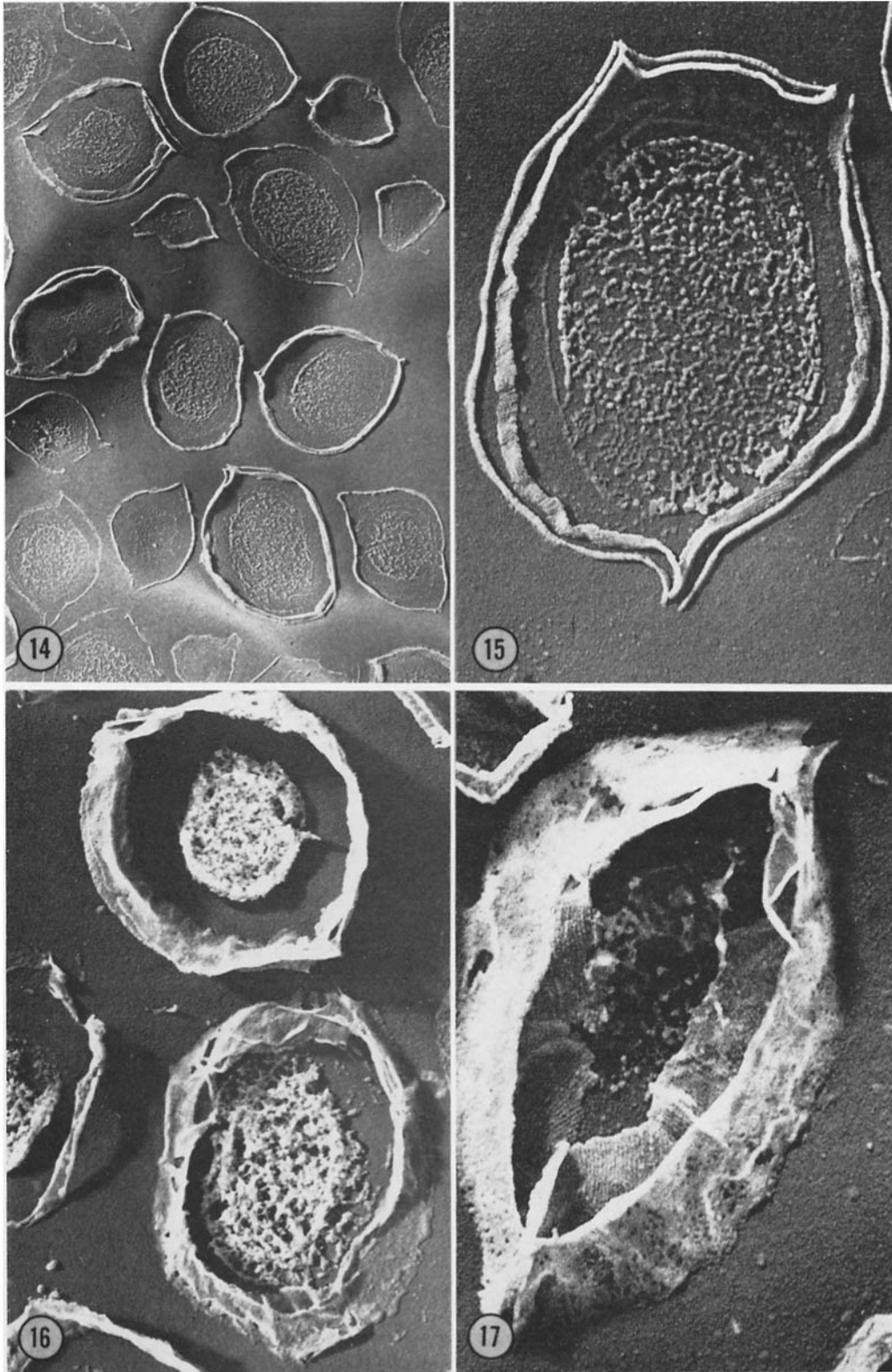

(B) ASH PATTERNS OF THIN-SECTIONED SPORES: Figs. 14 and 15 show typical low-temperature ash patterns of fairly thin sections of *B. megaterium* spores. The patterns were not grossly different from those from high-temperature incineration. The fine structure of the ashed middle layer of the coat looked the same, and the inner layer of the coat and the cortical region were likewise missing or represented by only a trace of ash. However, the core no longer survived as droplets, but now consisted of a granular reticulum. The outer layer of the coat was also different; it looked solid and structural rather than liquid, and seemed to contain more ash. Over-all, the ash pattern had a sharper, more three-dimensional appearance.

Preservation of the third dimension was strikingly demonstrated in the ash of thicker sections. Fig. 16 shows typical residues from sections which were probably more than 100  $m\mu$  thick before incineration. In this particular experiment, the methacrylate was not removed before incineration, to avoid possible surface-tension flattening of the sections, and was simply allowed to burn away. The ash of both the coats and the cores stood well up off the support film, and, in some cases, the ash did not even contact the support.

The reticular arrangement of the core ash was also quite evident in thick sections, as seen in Fig. 16. In some cases, however, the reticulum looked condensed, and the core was smaller than expected. This suggests that during or after incineration the structure contracted.

Thick sections occasionally provided rather informative views of the ashed spore coat. Fig. 17

shows a section cut almost tangentially to the surface of the spore, and including little else but the separated layers of the coat. The outer layer had a meshwork texture, in contrast to the fibril structure of the middle layer.

(C) ASH PATTERNS OF GERMINATED SPORE COATS: Fig. 19 shows typical coats shed from germinating *B. megaterium* spores. After such coats were incinerated by excited oxygen, they usually showed only a thin, single layer of ash with a meshwork texture similar to that shown by the outer layer of the coat in Fig. 17. Sometimes, however, the ash showed a double layer as shown in Fig. 18. Overlying the meshwork was a very thin ash residue with 100-A fibrillar structure. Apparently in these cases, the coat was deposited on the support film with the inside uppermost, and the innermost layer of the coat, if present, was burned away cleanly to reveal the middle layer.

In addition to spore coats, there were a few small fragments on the grids which could be recognized after incineration as isolated bits of the coat middle layer, free of the other layers. An example is shown in Fig. 20.

In neither the coat fragments nor the whole coats was any indication of the 100-A fine structure detected before incineration.

(D) ASH RESIDUES OF WHOLE SPORES: The improved preservation of the third dimension in low-temperature ash patterns of thick sections suggested that whole spores ought to be re-investigated by this technique.

Fig. 23 shows a typical field of whole *B. megaterium* spores after low-temperature incineration; a higher magnification view of two selected spores is shown in Fig. 21. The ash residue consisted of

---

FIGURE 18 Shed coat of a germinated *B. megaterium* spore after low-temperature incineration and uranium shadowing. A selected example which displays good preservation of fine structure. Note that the ash consists of two strata, the lower stratum being visible through holes in the upper, and also at the edges of the ash pattern. The upper stratum shows the 100-A fibrillar texture characteristic of the coat middle layer, while the lower stratum shows the meshwork texture of the outer layer.  $\times 50,000$ .

FIGURE 19 Typical shed coats of germinated *B. megaterium* spores, uranium shadowed. Unincinerated control preparation. A coarsely mottled texture (12) is evident, but no indication of the 100-A fibrillar structure can be seen in these unincinerated coats.  $\times 25,000$ .

FIGURE 20 Fragment of *B. megaterium* spore coat middle layer after low-temperature incineration and uranium shadowing. Note the many different orientations of the 100-A fibrillar arrays in the structure.  $\times 70,000$ .

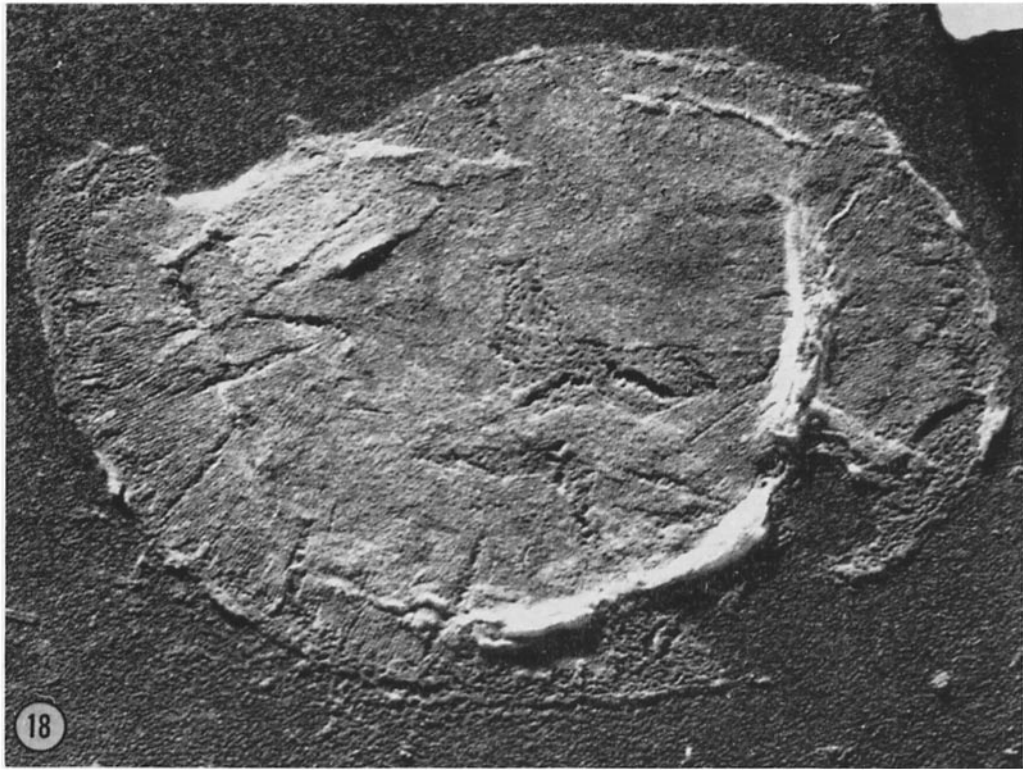

an opaque, spheroidal body about two-thirds the diameter of an intact spore, nearly always surrounded by a delicate, membranous structure. The latter, although sometimes collapsed, was commonly seen by profile and shadow contour to have the same size and shape as the original spore surface. Close examination (see Fig. 24) revealed a fine meshwork texture in the membrane similar to that shown by the outer layer of the coat in thin sections, and sometimes a hint of fibrillar texture underlying the meshwork.

There is little doubt that the membranous structure represented the ash of the spore coat. The central opaque body may have been simply the residue of the spore core, but the interpretation here is less certain and will be discussed below.

Rather similar results were obtained on whole *B. cereus* spores (see Fig. 22). With this spore, however, the ash of the coat appeared more fragile and was usually collapsed onto the central mass. Also, a fine ash residue clearly defined the site of the collapsed exosporium.

#### *Electron Diffraction of Ash Residues*

Unshadowed, incinerated preparations, similar to those described in the previous sections, were examined by selected area diffraction and selected

diffraction dark field to determine the presence of crystallinity in the ash.

Many residues of whole spores incinerated at high temperature gave a diffraction pattern consisting of a few discrete spots. As shown by dark-field examination, the diffraction came either from the edge of the central opaque mass or from the surrounding smaller ash granules. Not all parts of the residue contributed, however, and some residues gave no crystalline diffraction at all.

By contrast to whole spores, most residues from high-temperature incinerated thin sections did not diffract. The occasional residue which did invariably proved to be a coarse assemblage of large ash particles resulting from a thicker section. Adjacent coarse ash patterns often gave no diffraction. The diffracted ray usually came from a small, dense, angular granule seen inside the larger, droplet-shaped ash particle. In no case did diffraction originate from the discrete ash residue of the coat middle layer.

The low-temperature ashed preparations, including whole spores, spore coats, and thin sections, gave no detectable crystalline diffraction whatsoever.

These results suggest that the ash even of high-temperature preparations was mostly in an amorphous rather than crystalline form. It may be that

---

FIGURE 21 Selected examples of whole *B. megaterium* spores after low-temperature incineration and uranium shadowing. Note that in the lower spore residue a delicate, free-standing membrane of ash corresponds in size and shape to the spore coat. It surrounds an opaque mass of ash which may correspond to the spore core. The residue in the upper part of the field has apparently lost the ash membrane and consists simply of the central opaque mass. To the left of the lower ash residue, a small fragment of coat middle layer may be seen. Although not readily discerned at this magnification, it clearly shows the 100-A fibrillar fine structure.  $\times 30,000$ .

FIGURE 22 Selected example of whole *B. cereus* spores after low-temperature incineration and uranium shadowing. In addition to the delicate, free-standing ash residue of the spore coat, and the central, opaque mass of ash, note the distinct pattern on the support film which corresponds to the collapsed exosporium.  $\times 30,000$ .

FIGURE 23 Typical field of whole *B. megaterium* spores after low-temperature incineration and uranium shadowing. Although some of the ash residues show good spatial preservation of the delicate coat ash, in many cases it has more or less collapsed onto the central ash body.  $\times 10,000$ .

FIGURE 24 Part of a whole *B. megaterium* spore after low-temperature incineration. Not shadowed (and no contrast reversal). Note that the ashed coat displays over-all a meshwork structure. At the top of the field, however, where a tear in the ash membrane exposes a single thickness, there appear some slight indications of an underlying fibrillar structure.  $\times 65,000$ .



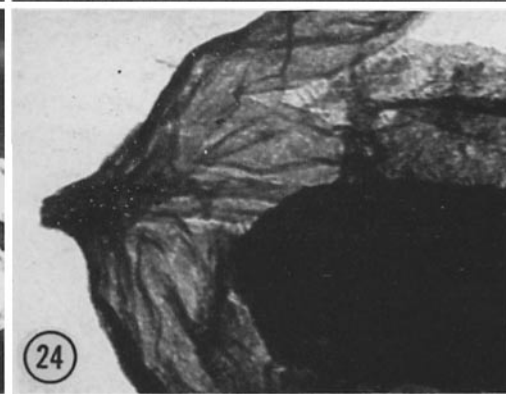
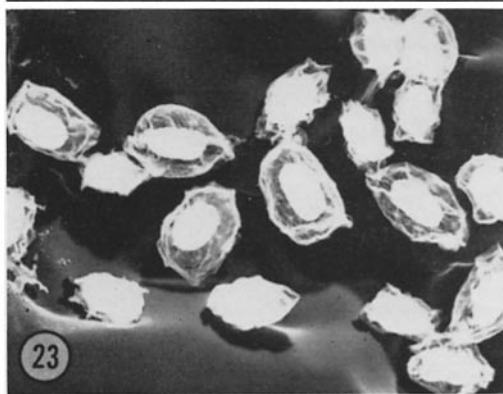
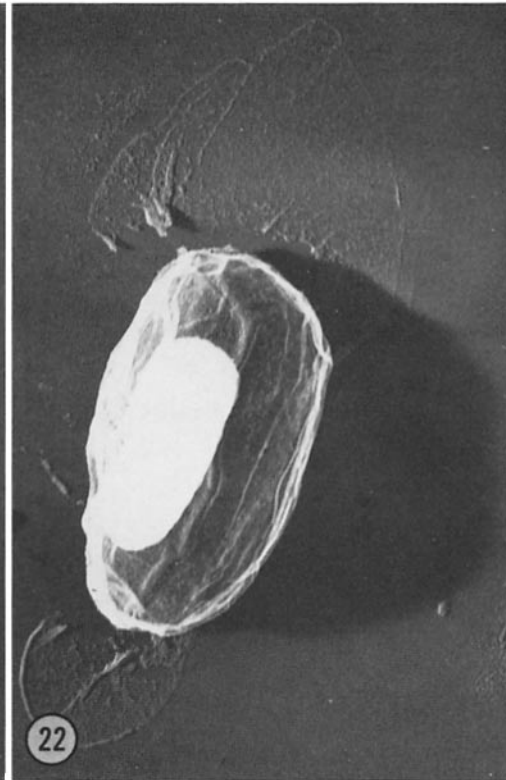
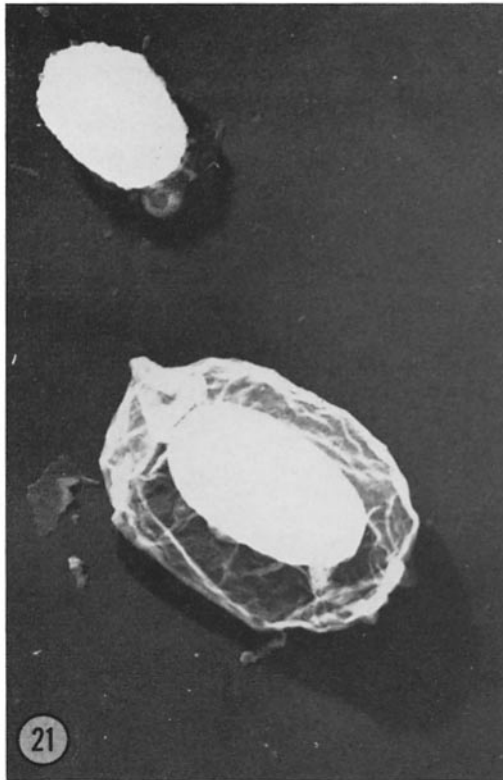

crystallinity could develop with time, however. In one experiment, a high-temperature incinerated thin-section preparation was re-examined in the electron microscope after several days' storage. The number of ash residues showing crystalline diffraction seemed to have greatly increased, and there was an increased number of dense, angular granules in the ash.

## DISCUSSION

### *The Over-All Distribution of Mineral Elements in Spores*

Electron microscopic observations of high-temperature incinerated whole spores do not support Knaysi's conclusion from the light microscope that spore minerals are confined to a peripheral layer surrounding a minerally poor core (17, 18). Judging by parallel observations with both microscopes, it seems likely that he misinterpreted the optical images of the ash residues. The ash was, in fact, largely concentrated in the center of the residue pattern rather than the periphery, but its generally amorphous appearance discouraged interpretation.

Low-temperature incineration of whole spores yielded less ambiguous ash residues and they suggest a distribution of minerals roughly converse to Knaysi's: a cortex poor in minerals surrounding a minerally rich core. A sizable, empty region lying beneath the delicate ash of the coat seemingly corresponded to the cortex, and a central ash mass could have been the residue of the core. It is tempting to take this as a true picture of the mineral distribution.

There is also the possibility of artifact, however. It may be that the central ash mass originated from the entire inner contents of the spore, both cortex and core, and reached its final size and shape simply by contraction. The central mass was somewhat variable in size and was slightly smaller, in many cases, than the original core. That the ash of the core, at least, can contract was suggested by the condensed reticulum in some low-temperature incinerated thick sections.

Further work is required to settle this question of artifact. A promising approach here may be the microincineration of chemically intact thin sections obtained by dry cutting of frozen-dried spores (38).

### *The Mineral Structure of the Spore Coat*

Perhaps the most interesting finding of the present investigation was the highly ordered, fibrillar fine structure of 100-Å periodicity in the ashed middle layer of the *B. megaterium* spore coat. It is remarkable that such finely organized detail should be preserved in an ash pattern. Nevertheless, there seems little doubt that the structure was, in fact, a completely incinerated ash. This was shown by control experiments. Also, it appears unlikely that the organization was a simple artifact of the ashing process. The ash was not crystalline, judging by the lack of electron diffraction, and its appearance was identical after the two widely differing processes of high-, and low-temperature incineration. It is easier to conclude that the organization came from pre-existing order in the intact spore.

There was no indication of this fibrillar structure in the present preparations before ashing, but it may correspond to the structure found earlier by Knaysi and Hillier in disintegrating *B. megaterium* spore coats (19). Their description is worth quoting. (P. 27) "... a coat consists of a matrix of beaded threads held together by a cementing material: The diameter of a bead is about 120 Å; the length of a thread varies considerably but is usually between  $6 \times 10^2$  and  $12 \times 10^2$  Å. These threads are invisible in the intact coat, but they become visible and are finally liberated by the dissolution of the cementing material. . . ." The present structure may also correspond to that seen by Robinow in thin-sectioned *B. megaterium* spores which had been treated with acid (28). The author writes (p. 309) "... in half a dozen spores with unusually thick coats, evidence of laminated construction of the spore coat was found and in some instances glancing sections revealed a regular array of short lengths of fine fibers in one of the layers. These fibers are of the same order of magnitude as those that were more clearly seen by Knaysi and Hillier. . . ."

Whether the fibrillar structure is present in spores other than *B. megaterium* remains unknown. However, the coherent, well preserved ash residue of the coat in low-temperature incinerated *B. cereus* spores suggests that they, too, may have it. Also, if the structure is associated with a laminated construction, as suggested by Robinow's report (38), it may well be present in other species. Stained thin sections of several different *Bacillus*

spores show a three-layered coat with fine laminations in the middle layer (40, 43).

A laminated construction would be consistent with the fibrillar structure seen in the ash patterns. In local regions, the fibrils were ordered precisely in parallel, but the orientation changed abruptly from one region to another. These different regions may reflect different laminae whose organization happened to survive preferentially in the incompletely preserved order of the ash. Lamination is especially suggested by transitional regions in the ash patterns where two fibrillar arrays were superimposed.

In contrast to the fibrillar structure of the middle layer, the low-temperature ashed outer layer of the *B. megaterium* spore coat showed a reticular or meshwork texture. This was less highly organized, and survived only poorly after high-temperature ashing, which suggests that its textural detail may have been simply an artifact of incineration. On the other hand, the ash texture is consistent with the rather coarse and irregularly layered or network construction of the outer coat layer which has been demonstrated in stained sections of several *Bacillus* spores (43).

The inner layer of the *B. megaterium* spore coat, seen in thin sections, left essentially no ash residue. However, owing to possible losses in the preparation, it remains unknown whether this layer in the intact spore was truly devoid of minerals.

Also unknown is the chemical nature and functional significance of any of these mineral structures in the coat. However, survival of at least the middle and outer layer minerals in isolated coats suggests the possibility of obtaining the structures in pure preparations for analysis.

#### *The Technique of High Resolution Microincineration*

In contrast to the broad literature on microincineration at the histological level of organization, there have been but few reports of its use in the study of fine structure. Perhaps the present demonstration of its high resolution capabilities will encourage further exploration of the technique.

The low-temperature, excited-oxygen technique seems a particularly promising approach for high resolution work. In conventional, high-temperature incineration the resolution is limited by coalescence of the ash into droplet-like particles (16, 20, 25, 34). The coalescence is apparently caused

not so much by moisture uptake in the ash as simply by melting. With low-temperature incineration the ash does not melt, but rather aggregates into a fine-textured granular reticulum allowing much sharper definition of the ash pattern.

The advantage of low-temperature incineration is especially obvious when applied to thick specimens. Unlike the high-temperature ash patterns which become coarser the thicker the specimen, the low-temperature ash has a texture independent of specimen thickness. Thick specimens should allow the study of chemically intact material, not limited by the difficulties of preparing ultrathin sections. Chemically intact, frozen thick sections can be prepared routinely, but similar ultrathin sections are a *tour de force* (10).

The low-temperature procedure should increase the sensitivity of microincineration for small amounts of mineral material, judging by the present results with the *B. cereus* exosporium. With increased definition of the ash pattern, the trace of ash could be more easily detected against the rough support film. Also, this new technique should make microincineration more quantitative, since volatile mineral substances which can be partially lost at high temperatures are retained by the low-temperature procedure (14).

Only future experiments will show the most valuable applications for high resolution microincineration. Besides its obvious use to determine the total over-all mineral distribution in an object, it may also be a means of selectively degrading specimens to reveal new structure. So was it used in the present investigation to demonstrate the fine structure of the spore coat. Objects which do not contain minerals may be saturated with metallic stains to delineate their structures (3, 41).

The technique is limited as a truly cytochemical tool since it directly demonstrates only a broad class of materials, the total minerals, rather than specific substances. Crystalline electron diffraction may identify specific substances in favorable cases. In the present experiments, however, much of the ash was not crystalline. Specific substances may also be identified by selective solubility experiments, either directly on the ash patterns or on the specimens before incineration. It may be possible to localize the ion-exchangeable calcium in spores (1) by this means. The interpretation of results will be greatly facilitated by the unique tolerance of incinerated specimens to previewing in the electron microscope; the most advantageous

specimens can thus be selected before incineration, and their photographs compared directly with the subsequent ash patterns.

The author thanks Mr. Gordon Alderton, Dr. J. C. Lewis, and Dr. L. E. Sacks for providing the purified spore preparations and for much valuable advice and discussion. He is also indebted to Mr. Lennell James for valuable technical assistance and to Miss Marion Long, Mr. Harold Lukens, Miss Geraldine Secor, and Mr. L. M. White for elemental analyses.

The technical staff of the Tracerlab Co., Richmond, California, made possible the early experiments with the Low Temperature Asher. Dr. H. R. Curran and Professor R. C. Williams kindly consented to review the manuscript.

Reference to a company or product name does not imply approval or recommendation of the product by the United States Department of Agriculture to the exclusion of others that may be suitable.

Received for publication, December 9, 1963.

#### REFERENCES

1. ALDERTON, G., and SNELL, N. S., Base exchange and heat resistance in bacterial spores, *Biochem. and Biophysic. Research Commun.*, 1963, **10**, 139.
2. ALLEN, R. J. L., The estimation of phosphorus, *Biochem. J.*, 1940, **34B**, 858.
3. BENDET, I., and TRONTL, Z., Incineration of virus particles, *J. Appl. Physics*, 1963, **34**, 2511.
4. BERNLOHR, R. W., and SIEVERT, C., Preliminary chemical characterization of the spore coats of *Bacillus licheniformis*, *Biochem. and Biophysic. Research Com.*, 1962, **9**, 32.
5. CHARNEY, J., FISHER, W. P., and HEGARTY, C. P., Manganese as an essential element for sporulation in the genus *Bacillus*, *J. Bact.*, 1951, **62**, 145.
6. CURRAN, H. R., BRUNSTETTER, B. C., and MEYERS, A. T., Spectrochemical analysis of vegetative cells and spores of bacteria, *J. Bact.*, 1943, **45**, 485.
7. DEAN, J. A., Flame Photometry, New York, McGraw-Hill Book Co., 1960, 354 pp.
8. DRAPER, M. H., and HODGE, A. J., Electron-induced microincineration with the electron microscope. I. Distribution of residual mineral content in vertebrate striated muscle, *Australian J. Exp. Biol. and Med. Sc.*, 1950, **28**, 549.
9. FERNÁNDEZ-MORÁN, H., Examination of brain tumor tissue with the electron microscope, *Ark. Zool.* (Sweden), 1948, **40**, 1.
10. FERNÁNDEZ-MORÁN, H., The submicroscopic organization of vertebrate nerve fibers, *Exp. Cell Research*, 1952, **3**, 282.
11. FITZ-JAMES, P. C., and YOUNG, I. E., Comparison of species and varieties of the genus *Bacillus*, Structure and nucleic acid content of spores, *J. Bact.*, 1959, **78**, 743.
12. FITZ-JAMES, P. C., and YOUNG, I. E., Cytological comparison of spores of different strains of *Bacillus megaterium*, *J. Bact.*, 1959, **78**, 755.
13. GLEIT, C. E., Electronic apparatus for ashing biological specimens, *Am. J. Med. Electronics*, 1963, **2**, 112.
14. GLEIT, C. E., and HOLLAND, W. D., Use of electrically excited oxygen for the low temperature decomposition of organic substances, *Anal. Chem.*, 1962, **34**, 1454.
15. GRELET, N., Le déterminisme de la sporulation de *Bacillus megatherium*. IV. Constituants minéraux du milieu synthétique nécessaires à la sporulation, *Ann. Inst. Pasteur*, 1952, **83**, 71.
16. HINTZSCHE, E., Das Aschenbild Tierischer Gewebe und Organe: Methodik, Ergebnisse und Bibliographie, Berlin, Springer-Verlag, 1956, 140 pp.
17. KNAYSI, G., Répartition de la matière minérale dans la spore de *Bacillus cereus*, *Ann. Inst. Pasteur*, 1961, **100**, 828.
18. KNAYSI, G., Determination, by spodography, of the intracellular distribution of mineral matter throughout the life history of *Bacillus cereus*, *J. Bact.*, 1961, **82**, 556.
19. KNAYSI, G., and HILLIER, J., Preliminary observations on the germination of the endospore in *Bacillus megatherium* and the structure of the spore coat, *J. Bact.*, 1949, **57**, 23.
20. KRUSZYNSKI, J., Further observations upon incinerated blood cells with the phase-contrast microscope, *Acta Anat.*, 1951, **13**, 337.
21. LECHOWICH, R. V., Studies on thermally induced changes in the bacterial endospore and on the relationship of its chemical composition to thermal resistance, Thesis, University of Illinois, Urbana, 1959, Ann Arbor, Michigan. University Microfilms, Inc.
22. LUKENS, H., SACKS, L. E., and ALDERTON, G., unpublished.
23. MAYALL, B. H., and ROBINOW, C., Observations with the electron microscope on the organization of the cortex of resting and germinating spores of *B. megaterium*, *J. Appl. Bact.*, 1957, **20**, 333.
24. NIEDERL, J. B., and NIEDERL, V., Micromethods

- of Quantitative Organic Analysis, New York, J. Wiley & Sons, 2nd edition, 1942, 101.
25. POLICARD, A., Twenty years of microincineration, Cytological result, *J. Roy. Micr. Soc.*, 1942, **62**, 25.
  26. POLICARD, A., and BESSIS, M., Étude au microscope électronique de la microincinération des cellules. Le leucocyte polynucléaire neutrophile, *Comp. rend. Soc. biol.*, 1952, **146**, 540.
  27. POWELL, J. F., and STRANGE, R. E., Biochemical changes occurring during the germination of bacterial spores, *Biochem. J.*, 1953, **54**, 205.
  28. ROBINOW, C. F., Spore structure as revealed by thin sections, *J. Bact.*, 1953, **66**, 300.
  29. ROBINOW, C. F., Morphology of bacterial spores, their development and germination, in *The Bacteria*, (I. C. Gunsalus, and R. Y. Stanier, editors), New York, Academic Press, Inc., 1960, **1**, 207.
  30. SACKS, L. E., and ALDERTON, G., Behavior of bacterial spores in aqueous polymer two-phase systems, *J. Bact.*, 1961, **82**, 331.
  31. SACKS, L. E., and BAILEY, G. F., Dry rupture of bacterial spores, *J. Bact.*, 1963, **85**, 720.
  32. SALTON, M. R. J., and MARSHALL, B., The composition of the spore wall and the wall of vegetative cells of *Bacillus subtilis*, *J. Gen. Microbiol.*, 1959, **21**, 415.
  33. SCOTT, G. H., Topographic similarities between materials revealed by ultraviolet light photomicrography of living cells and by microincineration, *Science*, 1932, **76**, 148.
  34. SCOTT, G. H., A critical study and review of the method of microincineration, *Protoplasma*, 1933, **20**, 133.
  35. SLEPECKY, R., and FOSTER, J. W., Alterations in metal content of spores of *Bacillus megaterium* and the effect on some spore properties, *J. Bact.*, 1959, **78**, 117.
  36. STRANGE, R. E., and DARK, F. A., The composition of the spore coats of *Bacillus megaterium*, *B. subtilis* and *B. cereus*, *Biochem. J.*, 1956, **62**, 459.
  37. SUGIYAMA, H., Studies on factors affecting the heat resistance of spores of *Clostridium botulinum*, *J. Bact.*, 1951, **62**, 81.
  38. THOMAS, R. S., Demonstration of structure-bound mineral constituents in thin-sectioned bacterial spores by ultramicroincineration, Fifth International Congress for Electron Microscopy, New York, Academic Press, Inc., 1962, **2**, RR-11.
  39. TINELLI, R., Étude de la biochimie de la sporulation chez *Bacillus megaterium*. I. Composition des spores obtenues par carence des différents substrats carbonés, *Ann. Inst. Pasteur*, 1955, **88**, 1.
  40. TOKUYASU, K., and YAMADA, E., Fine structure of *Bacillus subtilis*. II. Sporulation progress, *J. Biophysic. and Biochem. Cytol.*, 1959, **5**, 129.
  41. TURKEVICH, J., The world of fine particles, *Am. Scientist*, 1959, **47**, 97.
  42. TURKEVICH, J., and STREZNEWSKI, T., La réaction de l'oxygène avec des particules de carbone, *Rev. Inst. Français du Pétrole*, 1958, **13**, 686.
  43. WARTH, A. D., OHYE, D. F., and MURRELL, W. G., The composition and structure of bacterial spores, *J. Cell Biol.*, 1963, **16**, 579.
  44. WATSON, M. L., and ALDRIDGE, W. G., Methods for the use of indium as an electron stain for nucleic acids, *J. Biophysic. and Biochem. Cytol.*, 1961, **11**, 257.
  45. WILLIAMS, R. C., High-resolution electron microscopy of the particles of tobacco mosaic virus, *Biochim. et Biophysica Acta*, 1952, **8**, 227.
  46. WINDLE, J. J., and SACKS, L. E., Electron paramagnetic resonance of manganese (II) and copper (II) in spores, *Biochim. et Biophysica Acta*, 1963, **66**, 173.
  47. YOSHIDA, N., IZUMI, Y., TANI, J., TANAKA, S., TAKAISHI, K., HASHIMOTO, T., and FUKUI, K., Studies on the bacterial cell wall. XIII. Studies on the chemical composition of bacterial cell walls and spore membranes, *J. Bact.*, 1957, **74**, 94.
  48. YOUNG, I. E., and FITZ-JAMES, P. C., Chemical and morphological studies of bacterial spore formation. IV. The development of spore refractility, *J. Cell Biol.*, 1962, **12**, 115.