

# Tensile bond strength of four denture resins to porcelain teeth with different surface treatment

Mohamed El-Sheikh<sup>1\*</sup>, BDS, MS, PhD, John Powers<sup>2</sup>, PhD

<sup>1</sup>Department of Prosthodontics, Faculty of dentistry, Tanta University, Tanta, Egypt.

<sup>2</sup>Houston Biomaterials Research Center, University of Texas-Houston Dental Branch, Houston, TX, USA

**PURPOSE.** This study evaluated the bond strength between porcelain denture teeth (Bioblend 43D) and four different polymerized denture resins (Lucitone 199, Palapress, Acron MC, Triad) with and without a bonding agent and after four different types of surface treatment (polished, HF etched, sandblasted, air-abraded).

**MATERIALS AND METHODS.** Central incisor porcelain denture teeth were divided into 32 groups of 5 each. Tensile bond strength (MPa) was determined using a testing machine at crosshead speed of 0.5 mm/min. Mean and standard deviation are listed. Data were analyzed by two-way ANOVA. Means were compared by Tukey-Kramer intervals at 0.05 significance level. **RESULTS.** All surface treatment increased bond strength compared to polished surface and the highest bond strength was found with Palapress resin with etched porcelain surface (8.1 MPa). Bonding agent improved the bond strength of all denture resins to porcelain teeth. Superior bonding was found with Palapress and air-abraded porcelain (39 MPa). **CONCLUSION.** Resins with different curing methods affect the bond strength of porcelain teeth to denture bases. Superior bonding was found with auto-polymerized resin (Palapress). Application of ceramic primer and bonding agent to porcelain teeth with and without surface treatment will improve the bond strength of all denture resins to porcelain teeth. [*J Adv Prosthodont 2013;5:423-7*]

**KEY WORDS:** Acrylic resins; Denture bases; Porcelain denture teeth; Porcelain surface treatment

## INTRODUCTION

Several denture base materials and processing methods have been introduced to the profession, and each of them has claimed to produce a more accurate denture base. Bond failures between artificial tooth and denture base represent a problem for rehabilitation success. In order to minimize

these failures; many authors described main factors that can influence in the bond strength: tooth types and brands, resin types and brands, stress distribution, temperature of processing and processing variables.<sup>1</sup> There are many studies about bond strength between acrylic resin teeth and denture base resins,<sup>1,2</sup> but little has been published on bond strength between porcelain denture teeth and different denture base materials.<sup>3</sup> The use of porcelain teeth is advantageous in several clinical situations due to its high wear resistance, hardness and better color stability than acrylic teeth. However, lack of space often precludes the use of conventional retention by diatoric undercuts and metallic pins.<sup>4</sup>

The purpose of this study was to evaluate the bond strength between four different denture resins and porcelain denture teeth with and without a bonding agent and four different types of surface treatment. The first hypothesis was that there is no effect of different denture base resins on the bond strength with porcelain teeth. The second hypothesis was that there is no difference on bond strength among different surface treatment of porcelain teeth with and without ceramic primer and application of bonding agent.

Corresponding author:  
Mohamed M. El-Sheikh  
Department of Prosthodontics, Faculty of dentistry, Tanta University,  
Elgeish st. Tanta, Egypt  
Tel. 00201222204179; e-mail, address: melsheikh@yahoo.com  
Received May 7, 2013 / Last Revision October 31, 2013 / Accepted  
November 4, 2013

© 2013 The Korean Academy of Prosthodontics  
This is an Open Access article distributed under the terms of the Creative Commons Attribution Non-Commercial License (<http://creativecommons.org/licenses/by-nc/3.0>) which permits unrestricted non-commercial use, distribution, and reproduction in any medium, provided the original work is properly cited.

This work was presented in part at the annual meeting of the International Association for Dental Research before in Barcelona, Spain, from July 14-17, 2010.

## MATERIALS AND METHODS

A total of 160 central incisor porcelain denture teeth (Bioblend 43D, Dentsply international, York, PA, USA) were embedded in resin contained in mounting rings. Each specimen was ground with a series of abrasive papers (Silicon carbide grit sizes 120 through 600, Buehler Ltd, Lake Bluff, IL, USA) on a metallographic polisher (Ecomet 6, Buehler Ltd, Lake Bluff, IL, USA) to obtain a uniform, flat polished porcelain surface.

The polished porcelain specimens were divided into 32 groups of 5 each according to the following experimental design (Table 1): surface treatments (non, hydrofluoric acid etched, sandblasted, air-abraded), denture base resins according to the polymerization method: [heat-polymerized (Lucitone 199, Dentsply International York, PA, USA), self polymerized (Palapress Vario Heraeus Kulzer, Hanau, Germany), microwave-polymerized (Acron MC, GC Lab Tech., Lockport, IL, USA) and light-polymerized (Triad, Dentsply International York, PA, USA)], application or not of ceramic primer (batch No. 5ER, 3M ESPE, St. Paul, MN, USA) and bonding agent Scotchbond Multipurpose Adhesive (batch No. 5BK, 3M ESPE, St. Paul, MN, USA).

The specimens were isolated by use of polytetrafluoroethylene inverted cone molds (3 mm bond diameter, 4 mm high) (Fig. 1). The mold and the specimen in mounting ring were invested in dental stone. After boiling out, 40 polished specimens were left untreated as control; 40 specimens were acid etched (8% hydrofluoric acid, batch No. 079084, Bisco, Itasca, IL, USA) for 3 to 4 minutes, thoroughly rinsed for 45 seconds, and dried with air syringe; 40 speci-

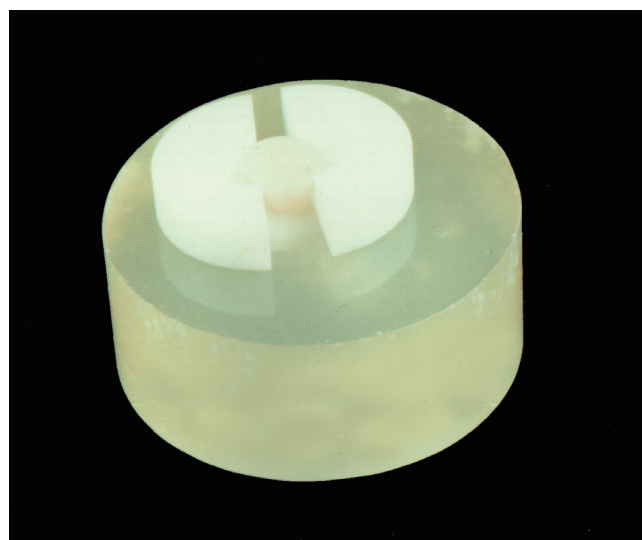

**Fig. 1.** The test specimen with polytetrafluoroethylene inverted cone mold.

mens were sandblasted (Renfert GmbH, Hilzingen, Germany) using 150  $\mu\text{m}$  aluminum oxide for 10 seconds at 0.41 MPa; and 40 specimens were abraded with 50  $\mu\text{m}$  aluminum oxide at 0.83 MPa (Sunrise Technologies, Inc., Vermont, CA, USA).

The different types of resin were mixed according to manufacturer's recommendation (Table 2) before packing the exposed tooth surfaces of 80 specimens were coated with ceramic primer and dried with an air syringe at a dis-

**Table 1.** Experimental design

Denture base resins	Ceramic primer and bonding agent	Surface treatments
Heat-polymerized (Lucitone 199)	No Yes	Non, HF etched, Sandblasted, Air-abraded
Self polymerized (Palapress Vario)	No Yes	Non, HF etched, Sandblasted, Air-abraded
Microwave-polymerized (Acron MC)	No Yes	Non, HF etched, Sandblasted, Air-abraded
Light-polymerized (Triad VLC)	No Yes	Non, HF etched, Sandblasted, Air-abraded

**Table 2.** Types of denture base materials used and curing methods

Denture Resin	Batch No.	Powder / Liquid Ratio	Curing Cycle
Lucitone 199	Powder: 951107 Liquid: 950928	35 cc/11 mL	9 hours at 73°C
Palapress Vario	Powder: 723714 Liquid: 260	10 g/7 mL	15 min at 55°C 2 Bar
Acron MC	Powder: 080861 Liquid: 072397	30 cc/9 mL	3 min Microwave at 500 W
Triad VLC	950308B	Sheet	10 min light curing

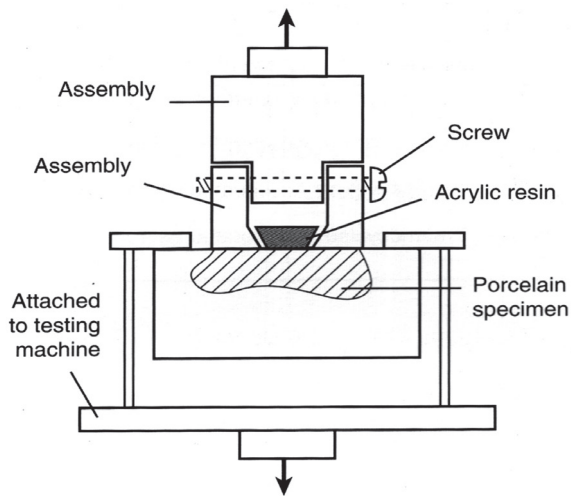

**Fig. 2.** Diagram showing the load applying testing machine.

tance of 15 cm from the surface for 10 seconds, then treated with adhesive and light cure for 10 seconds. The remaining 80 specimens were not treated with ceramic primer and bonding agent. The different type of resin were packed in the moulds, and polymerized.

After polymerization and deflasking, all samples were stored in water for 50 hours at 37°C before testing. Then all samples were subjected to a tensile load perpendicular to the tooth surface using the loading device as illustrated in (Fig. 2). The crosshead speed of the universal testing machine (8501, Instron Co., Canton, MA, USA) was 0.5 mm per minute. The tensile bond strength was calculated as the failure load divided by bonding area of the resin.

Mean bond strength and standard deviation were calculated for each group, and the data for bonded and non bonded samples were analyzed by two-way ANOVA (Super ANOVA, Abacus Concepts, Berkeley, CA, USA). Means were compared by Tukey-Kramer intervals at 0.05 significance level. Differences between means greater than the appropriate Tukey-Kramer intervals were considered statistically significant.

**Table 3.** Mean bond strength (MPa) and standard deviation in parenthesis of denture resins to porcelain denture teeth without ceramic primer and bonding agent (n=5)

Denture resin	Polished	Etched	Sandblasted	Air abraded
Lucitone 199	1.0 (0.7)*	1.6 (0.4)	0.7 (0.3)	0.5 (0.2)
Palapress	1.2 (0.6)	8.1 (2.8)	3.7 (1.9)	5.3 (3.0)
Acron MC	0.3 (0.1)	3.9 (2.4)	0.6 (0.3)	2.2 (0.7)
Triad VLC	1.6 (0.6)	4.5 (2.0)	3.6 (1.0)	3.1 (1.5)

Tukey-Kramer intervals ( $P=.05$ ) for comparisons of specimens without ceramic primer and bonding agent among surface treatment and between denture resins were both 1.2 MPa.

\*Means and standard deviation in parentheses.

## RESULTS

Means and standard deviations of the bond strength of specimens without ceramic primer and bonding agent are shown in Table 3 and Fig. 3. A two-way ANOVA is shown in Table 4. Tukey-Kramer intervals for comparisons among surface treatment and between denture resins were both 1.2 MPa. All surface treatment increased bond strength compared to polished surface, and the highest bond strength was found with Palapress resin with etched porcelain surface  $8.1 \pm 2.8$  MPa.

Means and standard deviations of the bond strength of specimens with ceramic primer and bonding agent are listed in Table 5 and Fig. 4. A two-way ANOVA is shown in Table 6. Tukey-Kramer intervals for comparisons among surface treatment and between denture resins were both 5 MPa. Application of ceramic primer and bonding agent improved bond strength between all tested denture resin and porcelain teeth. The highest bond strength was observed with Palapress resin and air-abraded porcelain surface  $39 \pm 3$  MPa.

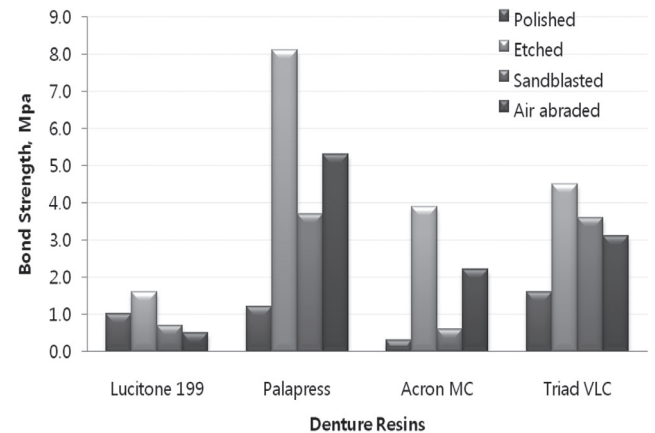

**Fig. 3.** Bond strength (MPa) of denture resins to porcelain teeth without ceramic primer and bonding agent.

**Table 4.** Analysis of variance of specimens without ceramic primer and bonding agent as affected by type of resin and surface treatment

	df	SS	MS	F	P
Resin	3	153.116	51.039	23.099	.0001*
Surface treatment	3	127.924	42.641	19.299	.0001*
Resin x surface treatment	9	63.803	7.089	3.208	.0029*
Residual	64	141.409	2.210		

**Table 5.** Mean bond strength (MPa) and standard deviation in parenthesis of denture resins to porcelain denture teeth with ceramic primer and bonding agent (n=5)

Denture resin	Polished	Etched	Sandblasted	Air abraded
Lucitone 199	25 (7)	13 (1)	33 (5)	22 (8)
Palapress	29 (6)	32 (4)	28 (4)	39 (3)
Acron MC	22 (8)	29 (6)	27 (6)	28 (7)
Triad VLC	23 (8)	24 (6)	32 (5)	32 (7)

Tukey-Kramer intervals ( $P=.05$ ) for comparisons of specimens with ceramic primer and bonding agent among surface treatment and between denture resin were both 5 MPa.

\*Means and standard deviation in parentheses.

**Table 6.** Analysis of variance of specimens with ceramic primer and bonding agent as affected by type of resin and surface treatment

	df	SS	MS	F	P
Resin	3	845.160	281.720	7.731	.0002*
Surface treatment	3	636.252	212.084	5.820	.0014*
Resin x surface treatment	9	1268.643	140.960	3.868	.0006*
Residual	64	2332.192	36.440		

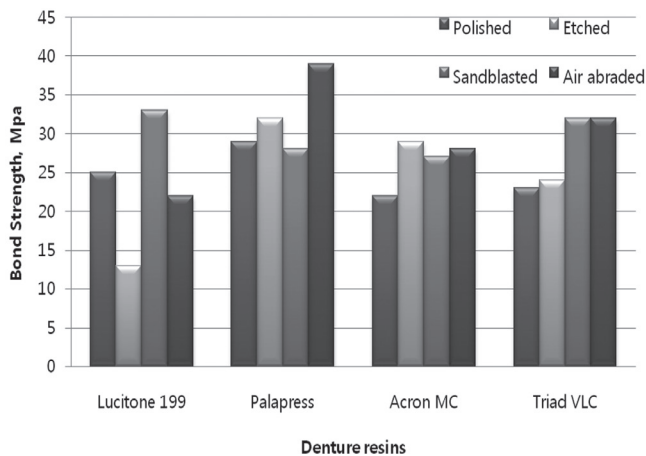

**Fig. 4.** Bond strength (MPa) of denture resins to porcelain teeth with ceramic primer and bonding agent.

## DISCUSSION

In this study, without ceramic primer and bonding the highest tensile bond strength value was displayed in Palapress resin with etched porcelain surface with statistically significant difference from other tested surface treatments. This is because the process of etching changes the surface morphology and increases the ceramic surface area which favored infiltration and retention of resin.<sup>5,6</sup> This is in agreement with previous researches finding that etching with 8% hydrofluoric acid gel produced higher bond strength than sandblasting with a series of  $Al_2O_3$ .<sup>7,8</sup>

Acron MC resin groups exhibited the lowest bond strengths to polished porcelain denture teeth indicating that the type of acrylic resin influenced tooth-to-base bond strength. It was also declared that Acron MC denture base material may have exhibited less cross-linking, which left fewer functional groups available for bonding.<sup>9</sup> Moreover, since microwave processing requires significantly less

polymerization time which reduces contact time between unpolymerized resin and teeth surface, this type of resin may result in weak bonding strength.<sup>10</sup>

Triad did not give promising results compared to Palapress or Lucitone denture base materials when used without application of primer and bond. This is may be attributed to the fact that Triad resin was not capable of diffusing effectively into the tooth surface to ensure a satisfactory bond due to poor wettability as a result of higher viscosity exhibited by this material.<sup>11,12</sup>

When using ceramic primer and bonding agent, the results were higher in bond strength between the porcelain teeth and the four tested acrylic denture bases than that of samples without primer and bond. This might be because silane primer enhances porcelain-resin bonds by promoting the wetting of the ceramic surface and thus making the penetration of the resin into the microscopic porosities of the acid conditioned porcelain more complete.<sup>13,14</sup>

While silane application after HF-etching was thought to be the most effective method for improving resin bonding with silica-based ceramics,<sup>15</sup> in this study; using silane primer with air abrasion gave significant higher results as air abrasion with Al<sub>2</sub>O<sub>3</sub> increase surface roughness, energy and wettability of high-strength ceramic materials than hydrofluoric acid etching.<sup>16</sup> This is in agreement with Spohr *et al.*<sup>5</sup> and Marchack *et al.*<sup>17</sup> who recommended using the high energy air abrasion with 50 µm Al<sub>2</sub>O<sub>3</sub> to improve bond strength of denture resin bonded to porcelain teeth instead of sandblasting with 150 µm Al<sub>2</sub>O<sub>3</sub> because the velocity of the abrasive particles of the later is insufficient to cause sufficient roughness of strong dense porcelain surface.

Application of primer and bonding agent with the sandblasted porcelain teeth gives high bond strength with Lucitone denture bases; which confirms previous results.<sup>3</sup>

Either without or with the application of primer and bonding agent. Palapress proved to bond well with porcelain denture teeth with all surface treatment forms. This may be attributed to the fact that Palapress is a fluid resin, with low viscosity mix which may penetrate into tiny irregularities and form micromechanical bond to denture porcelain teeth.

## CONCLUSION

Higher bond strength values were obtained when self polymerized resin (Palapress) was used with porcelain teeth. Etching with hydrofluoric acid or air-abrasion surface treatments and using ceramic primer and bonding agent was effective in increasing tensile bond strength of porcelain teeth to acrylic denture bases.

## REFERENCES

- Büyükyılmaz S, Ruyter IE. The effects of polymerization temperature on the acrylic resin denture base-tooth bond. *Int J Prosthodont* 1997;10:49-54.
- Takahashi Y, Chai J, Takahashi T, Habu T. Bond strength of denture teeth to denture base resins. *Int J Prosthodont* 2000; 13:59-65.
- El-Sheikh MM, Powers JM. Tensile bond strength of porcelain teeth to denture resin before and after aging. *Int J Prosthodont* 1998;11:16-20.
- Craig RG. Prosthetic appliance of polymers. In: *Restorative Dental Materials*. 11<sup>th</sup> ed. St Louis: Mosby, 2002, p. 570-1.
- Spohr AM, Sobrinho LC, Consani S, Sinhoreti MA, Knowles JC. Influence of surface conditions and silane agent on the bond of resin to IPS Empress 2 ceramic. *Int J Prosthodont* 2003;16:277-82.
- Filho AM, Vieira LC, Araújo E, Monteiro Júnior S. Effect of different ceramic surface treatments on resin microtensile bond strength. *J Prosthodont* 2004;13:28-35.
- Roulet JF, Söderholm KJ, Longmate J. Effects of treatment and storage conditions on ceramic/composite bond strength. *J Dent Res* 1995;74:381-7.
- Kato H, Matsumura H, Atsuta M. Effect of etching and sandblasting on bond strength to sintered porcelain of unfilled resin. *J Oral Rehabil* 2000;27:103-10.
- Yunus N, Harrison A, Huggett R. Effect of microwave irradiation on the flexural strength and residual monomer levels of an acrylic resin repair material. *J Oral Rehabil* 1994;21: 641-8.
- Schneider RL, Curtis ER, Clancy JM. Tensile bond strength of acrylic resin denture teeth to a microwave- or heat-processed denture base. *J Prosthet Dent* 2002;88:145-50.
- Cunningham JL. Shear bond strength of resin teeth to heat-cured and light-cured denture base resin. *J Oral Rehabil* 2000; 27:312-6.
- Clancy JM, Hawkins LF, Keller JC, Boyer DB. Bond strength and failure analysis of light-cured denture resins bonded to denture teeth. *J Prosthet Dent* 1991;65:315-24.
- Jardel V, Degrange M, Picard B, Derrien G. Correlation of topography to bond strength of etched ceramic. *Int J Prosthodont* 1999;12:59-64.
- Ozcan M. A practical method for chairside repair of debonded porcelain denture teeth. *J Prosthodont* 2006;15:47-50.
- Panah FG, Rezai SM, Ahmadian L. The influence of ceramic surface treatments on the micro-shear bond strength of composite resin to IPS Empress 2. *J Prosthodont* 2008;17: 409-14.
- Wegner SM, Kern M. Long-term resin bond strength to zirconia ceramic. *J Adhes Dent* 2000;2:139-47.
- Marchack BW, Yu Z, Zhao XY, White SN. Adhesion of denture tooth porcelain to heat-polymerized denture resin. *J Prosthet Dent* 1995;74:242-9.