

Access this article online

Quick Response Code:



Website:  
www.jehp.net

DOI:  
10.4103/jehp.jehp\_678\_21

# Validity and reliability of the Persian version of the exercise self-efficacy scale in people with multiple sclerosis

Faride Goldoust, Maryam Abolhasani<sup>1</sup>, Elham Shakibazadeh, Mehdi Yaseri<sup>2</sup>, Gholamreza Garmaroudi

## Abstract:

**BACKGROUND:** Exercise self-efficacy has been identified as one of the primary determinants of physical activity in people with multiple sclerosis (MS). Therefore, assessment of exercise self-efficacy is important to be measured with valid and reliable scale to provide tailored interventions.

**MATERIALS AND METHODS:** The English version of the exercise self-efficacy scale was translated into Persian using a forward-backward translation approach. Factorial validity was conducted using the exploratory factor analysis (EFA) and the confirmatory factor analysis (CFA). In addition, construct validity was performed using convergent and known-group validity. Reliability was evaluated by internal consistency and test-retest reliability. Participants were recruited from two hospitals (MS clinics).

**RESULTS:** Exploratory factor analysis identified a single factor structure which explained 64.7% variance in exercise self-efficacy scale (EXSE). CFA supported a single factor structure with a good model fit. Average variance extracted = 0.60 and composite reliability = 0.93 values confirmed the convergent validity. The known-group validity was verified with significant differences between subgroups. The Cronbach's alpha coefficient = 0.93 and intraclass correlation coefficient = 0.85 supported reliability of EXSE scale.

**CONCLUSIONS:** Our findings provided sufficient evidence of validity and reliability for EXSE scale in people with MS. This measure can utilize by researchers and health-care providers in studies and clinical practice as a robust measure to assess exercise self-efficacy and to develop interventions in people with MS.

## Keywords:

Exercise self-efficacy, multiple sclerosis, validity and reliability

Department of Health Education and Promotion, School of Public Health, Tehran University of Medical Sciences, Tehran, Iran, <sup>1</sup>Multiple Sclerosis Research Center, Neuroscience Institute, Tehran University of Medical Sciences, Tehran, Iran, <sup>2</sup>Department of Epidemiology and Biostatistics, School of Public Health, Tehran University of Medical Sciences, Tehran, Iran

## Address for correspondence:

Prof. Gholamreza Garmaroudi, Department of Health Education and Promotion, School of Public Health, Tehran University of Medical Sciences, Tehran, Iran.  
E-mail: garmaroudi@tums.ac.ir

Received: 16-05-2021  
Accepted: 05-08-2021  
Published: 28-04-2022

## Introduction

Multiple sclerosis (MS) is the most common autoimmune disease in central nervous system that affects young adults,<sup>[1]</sup> especially women. MS is characterized with inflammation, demyelination, and lesions.<sup>[2,3]</sup>

The patients with MS experience different symptom including visual problems, balance disorder, spasticity, cognitive dysfunctions, and mobility impairment.<sup>[4,5]</sup> The patients with MS also suffer from pain, fatigue, depression, and muscle weakness.<sup>[6,7]</sup>

This is an open access journal, and articles are distributed under the terms of the Creative Commons Attribution-NonCommercial-ShareAlike 4.0 License, which allows others to remix, tweak, and build upon the work non-commercially, as long as appropriate credit is given and the new creations are licensed under the identical terms.

For reprints contact: WKHLRPMedknow\_reprints@wolterskluwer.com

Patients' activities decrease due to increase these symptoms and physical inactivity leads to exacerbation of symptoms and decrease quality of life (QOL).<sup>[8,9]</sup> There is abundant evidence which indicate that physical activity (PA) has considerable benefits for improving fatigue, balance, coordination, and health-related QOL.<sup>[5,6,10]</sup>

Despite growing evidence of the benefits of PA, recent studies indicated that the majority of persons with MS are engaging in insufficient PA.<sup>[11,12]</sup> Therefore, it is important to identify and assess factors related to PA. Two review studies reported that self-efficacy

**How to cite this article:** Goldoust F, Abolhasani M, Shakibazadeh E, Yaseri M, Garmaroudi G. Validity and reliability of the Persian version of the exercise self-efficacy scale in people with multiple sclerosis. J Edu Health Promot 2022;11:132.

is one of the most powerful predictors of PA among persons with MS.<sup>[13,14]</sup> Self-efficacy is a primary or focal construct of social cognitive theory which was initially developed by Bandura<sup>[15]</sup> and has been widely used in various populations and individuals with MS.<sup>[16]</sup> Self-efficacy is an individual's confidence in his or her ability to perform a specific behavior. In other words, self-efficacy refers to the confidence that a person has in overcoming barriers while performing a given behavior. For example, to become more physically active, one must overcome several barriers, such as being tired, feeling depressed, feeling anxious, and encountering bad weather.<sup>[17]</sup> The people with higher levels of self-efficacy have more effort to face challenges than persons with low levels of self-efficacy.<sup>[18]</sup> As noted, exercise self-efficacy has been identified as one of the primary determinants of PA in people with MS.<sup>[13,14]</sup> Therefore, exercise self-efficacy needs to be measured with valid and reliable scale. McAuley initially developed a scale of exercise self-efficacy in middle-age<sup>[19]</sup> that this scale has been used in people with MS.<sup>[16,20]</sup> Resnick and Jenkins revised and validated this scale in older adults,<sup>[21,22]</sup> patients with epilepsy,<sup>[23]</sup> and stroke survivors.<sup>[24]</sup> This instrument is a short scale and appropriate for assessing exercise self-efficacy in individuals with MS. However, to our knowledge, there is insufficient evidence for the validity of this measure in people with MS.

The purpose of this study is validity and reliability of exercise self-efficacy scale in people with MS. Understanding the level of exercise self-efficacy in individuals with MS could help health providers to develop interventions for increasing self-efficacy and PA in this population.

## Materials and Methods

### Procedures and participants

#### *Study design and setting*

This cross-sectional study was conducted from April to November 2020 among patients with MS referred to MS clinics in Tehran, Iran.

#### *Study participants and sampling*

Participants were recruited from MS clinics of two hospitals affiliated to the Tehran University of Medical Sciences (TUMS) in Tehran, Iran. The sample size was calculated based on the ratio of the number of subjects per item required for a factor analysis. This is acceptable method that the minimum ratio of sample per item should be 10:1.<sup>[25]</sup> We considered 210 samples for confirmatory factor analysis (CFA) and 110 samples for exploratory factor analysis in the present study.

The first, individuals with MS were screened based on inclusion criteria then a member of the research team described the research and its procedures.

The inclusion criteria were (a) definite diagnosis of MS, (b) relapse-free in the past 30 days, (c) age of 18–65 years, (d) willingness to complete the questionnaire. The expanded disability status scale (EDSS) of participants was assessed by neurologists according to standard clinical procedures in MS clinics in the hospital settings.

### Data collection and technique

We used the exercise self-efficacy scale which has been revised by Resnick and Jenkins.<sup>[21]</sup> This measure assesses an individual's belief in overcoming barriers while performing PA. This scale has 9 items that main statement is "How confident are you that you could exercise three times per week for 30 min if...." Items are rated on a scale ranging from 0 (not confident at all) to 100 (highly confident) and averaged into a total score. Higher scores reflect greater exercise self-efficacy to engage in PA.

PA was measured using the Godin Leisure-Time Exercise questionnaire (GLTEQ) which is a self-reported scale with two parts.<sup>[26]</sup> We used only the first part in this study which includes three items which measure the frequency of strenuous, moderate, and mild exercise for more than 15 min in during a typical week. The frequencies of strenuous, moderate, and mild activities were multiplied by 9, 5, and 3 metabolic equivalents (METs), respectively, and were summed into a total score. There is evidence for the validity this measure in persons with MS.<sup>[27]</sup> We used a cut point at 24 units to determine the activity level of the participants (i.e., 24 units or more: active and 23 units or less: Insufficiently active).<sup>[26]</sup>

After attaining permission to perform the translation and validation the exercise self-efficacy scale from the authors, we followed the process of forward and back translations of this scale into Persian version. Two translators independently translated the exercise self-efficacy scale from English into Persian version. A panel of 5 experts (one sport medicine specialist, four health educators) compared translated items to examine the equivalence of meaning. The discrepancies were amended and then one consensus version was approved.

Two other translators independently performed backward translation from Persian to English and the panel of experts compared these versions with the original questionnaire, and then, the backward translation version was verified by original developer. Ultimately, the panel of experts confirmed the final version. The Persian version of measure was examined to assess the face validity by 20 patients with MS. They were asked to respond to the questionnaire and express any ambiguity or problems in understanding. Patients reported that the items were clear and there was no ambiguity. Then, we tested the validity and reliability of the questionnaire. The factorial validity was assessed

using both exploratory factor analysis (EFA) and CFA. Moreover, psychometrics of the questionnaire was followed using convergent validity, known-group validity, and reliability of EXSE scale. All questionnaires were checked for incomplete responses.

### Ethical consideration

This project was approved by the ethics committee of TUMS. Permission to perform the translation and validation the ESE scale from the authors was attained. Participants signed a written informed consent and completed measures in MS clinics.

### Statistical analysis

Descriptive statistics were presented as frequency, mean, and standard deviation (SD). The skewness and kurtosis were used to test the normality of EXSE scale. All data were analyzed using SPSS version 23 (IBM Corporation, Armonk, NY, USA) and Amos 20. Factor analysis was performed using EFA and CFA. For the factor loadings, a value of 0.4 or higher was considered as acceptable values.<sup>[28]</sup> In CFA, the model fit was examined using the following indices: Chi-square/degrees of freedom ( $\chi^2/df < 3$ ), Root Mean Square Error of Approximation (RMSEA  $\leq 0.06$ ), Goodness-of-fit index (GFI  $> 0.95$ ), comparative fit index (CFI  $> 0.95$ ), Tucker-Lewis index (TLI  $> 0.94$ ).<sup>[29]</sup>

In addition, we tested convergent validity and known-group validity. Convergent validity was assessed based on relevant criteria including average variance extracted (AVE  $> 0.5$ ) and composite reliability (CR  $> 0.7$ ).<sup>[30]</sup>

Known-group validity was tested using an independent *t*-test to compare the EXSE score between patients with disability status (EDSS  $\leq 2$  and EDSS  $\geq 2.5$ ) as well as people with insufficient exercise (GLTEQ  $< 24$ ) and sufficient exercise (GLTEQ  $\geq 24$ ) in people with MS. Known-group validity measures an instrument's ability to distinguish among distinct groups.

Moreover, construct validity was examined using Pearson correlations between EXSE score with physical activity (GLTEQ). Guidelines of 1, 3, and 5 were used for judging the magnitude of the correlations as small, moderate, and large, respectively.<sup>[31]</sup>

The internal consistency of the instrument was calculated using Cronbach's alpha coefficient. Values  $> 0.7$  indicate high internal consistency.

Test-retest reliability was conducted by 30 participants over a 2-week interval and assessed using intraclass correlation coefficient (ICC).<sup>[32]</sup> All of these patients completed the measures and were included in the final data analysis.

## Results

### Participant characteristics

The demographic and clinical characteristics of the total participants ( $n = 210$ ) are presented in Table 1. Most participants were female, were married, and had university degree with the mean age 34.2 years (SD = 8.1). Ninety-six percent had relapsing remitting MS (RRMS) and the mean duration of disease was 7.6 years (SD = 5.2). The median EDSS was 2. The mean score of the EXSE total was 50.2 (SD = 24.3), while the mean scores of items ranged from 4.2 to 6.7 [Table 2]. The normality of each item was assessed based on the values of skewness and kurtosis. The range of skewness was between 0.06 and 0.58 and the range of kurtosis was between  $-0.82$  and  $-1.4$ , indicating that the items of the EXSE scale were normally distributed. The ceiling effect was 3.8%. While there was no the floor effect of the total scale.

### Exploratory factor analysis

Exploratory factor analysis was conducted ( $n = 110$ ) on the 9 items of EXSE scale. The results of exploratory factor analysis supported the validity of the EXSE scale. The result of Bartlett's test of Sphericity was significant ( $\chi^2 = 717.26$ ,  $df = 36$ ,  $P < 0.001$ ) which allowed performing factor analysis for data. The Kaiser-Meyer-Olkin value was very good (0.89) indicating sampling adequacy for factor analysis. Based on the scree-plot and the eigenvalue ( $> 1$ ), a single factor structure was retained and explained 64.7% of the variance in the scale. All items had factor loadings higher of 0.4 which were ranged from 0.73 to 0.84 [Table 3].

**Table 1: Sample characteristics (n=210)**

Characteristics	n (%)
Sex	
Female	168 (80)
Male	42 (20)
Marital status	
Single	75 (35.7)
Married	127 (60.5)
Divorced	8 (3.8)
Education	
Diploma and lower	69 (32.9)
University degree	141 (67.1)
Employed	
Yes	92 (43.8)
No	118 (56.2)
Disability status (EDSS)	
1-2	184 (87.6)
2.5	11 (5.2)
3	9 (4.3)
3.5	6 (2.9)

EDSS=Expanded disability status scale

**Table 2: Mean, skewness, and kurtosis of exercise self-efficacy scale items (n=210)**

	Items	Mean (SD)	Range	Skewness	Kurtosis
1	1-The weather was bothering you	48.2 (29.4)	0–100	0.27	-1.06
2	2-You were bored by the program or activity	51.1 (29.8)	0–100	0.23	-1.22
3	3-you felt pain when exercising	43.0 (28.2)	0–100	0.58	-0.82
4	4-You had to exercise alone	67.4 (31.3)	0–100	-0.51	-1.10
5	5-You did not enjoy it	47.7 (29.2)	0–100	0.38	-0.95
6	6-You were too busy with other activities	44.7 (29.2)	0–100	0.50	-0.98
7	7-You felt tired	45.1 (29.0)	0–1000	0.52	-0.91
8	8-You felt stressed	52.5 (30.9)	0–100	0.06	-1.33
9	9-You felt depressed	52.0 (32.9)	0–100	0.22	-1.42

SD=Standard deviation

**Table 3: Factor loadings of items in exploratory factor analysis (single factor)**

Items	Factor loadings
1 The weather was bothering you	0.82
2 You were bored by the program or activity	0.81
3 you felt pain when exercising	0.82
4 You had to exercise alone	0.76
5 You did not enjoy it	0.73
6 You were too busy with other activities	0.78
7 You felt tired	0.84
8 You felt stressed	0.84
9 You felt depressed	0.81
Eigenvalue	5.82
Percentage of variance	64.74

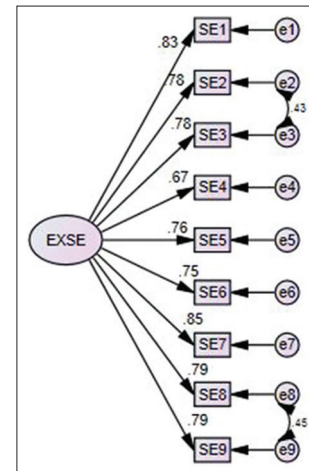

Figure 1: Measurement model exercise self-efficacy

**Confirmatory factor analysis**

The CFA ( $n = 210$ ) confirmed single factor structure with a good model fit ( $\chi^2/df = 1.6$ , RMSEA = 0.05, CFI = 0.99, GFI = 0.97, TLI = 0.99). All items had factor loadings of greater of 0.4 which were ranged from 0.67 to 0.85 [Figure 1].

**Convergent validity and known-group validity**

Convergent validity analysis demonstrated AVE and CR values were 0.60 and 0.93, respectively.

The CR and AVE values were higher than the recommended values indicating a good convergent validity of the EXSE scale.

The results of known-group validity are presented in Table 4. There were significant differences in EXSE scores between subgroups ( $P < 0.01$ ). Patients with lower disability had significantly higher scores of EXSE than those with higher disability. People who had higher PA levels reported higher EXSE score than those had lower PA levels. There was a significant and moderate correlation between the EXSE scores and PA ( $r = 0.39$ ;  $P < 0.001$ ).

**Reliability**

The Cronbach’s alpha coefficient was 0.93 demonstrating a high internal consistency.

In test-retest analysis, ICC was 0.85 indicating stability of the EXSE scale.

**Discussion**

The purpose of this study was to test validity and reliability of the exercise self-efficacy scale in people with MS. The results of this study provide evidence for psychometric properties of exercise self-efficacy instrument in individuals with MS. The first, the standard forward-backward translation process was conducted, and then, the validity and reliability of exercise self-efficacy were followed.

Factorial validity of the exercise self-efficacy scale was evaluated by exploratory factor analysis (EFA) and CFA. The preliminary findings of EFA identified a single factor structure that explained 64.7% of the variance in the measure. All items had acceptable factor loadings. These results are consistent with previous studies among older adults<sup>[21]</sup> and people with stroke survivors<sup>[24]</sup> reported exercise self-efficacy with a single factor structure.

The results of CFA supported the single factor structure with a good model fit for data and significant factor loadings. These findings were consistent with previous

**Table 4: Comparison exercise self-efficacy between subgroups for known-group validity**

Groups	Mean (SD)	T	P
EDSS ≤2	51.54 (24.02)	2.13	0.03
EDSS ≥2.5	40.76 (24.78)		
GLTEQ <24	47.36 (23.6)	4.98	0.001
GLTEQ ≥24	72.26 (17.6)		

EDSS=Expanded disability status scale, GLTEQ=Godin leisure-time exercise questionnaire, SD=Standard deviation

research that factor loadings were  $>0.5$ ,<sup>[22,24]</sup> but reported fair fit for the data.<sup>[22]</sup>

In the present study, AVE and CR values were greater than recommended values that these criteria confirmed convergent validity of this measure. Moreover, a significant and moderate correlation between exercise self-efficacy and PA behavior provided other evidence for construct validity.

In our study, there were significant differences between subgroups in exercise self-efficacy which verified known-group validity. The patients with more disability status had lower exercise self-efficacy as well as the people who had higher PA levels reported greater exercise self-efficacy score. Finally, internal consistency of this scale was good indicating reliability of this measure. This finding is comparable with previous results among stroke survivors (0.86) and older adult (0.89). Likewise, Test-retest reliability of the EXSE scale provided acceptable evidence of the stability of the scale.

### Limitation and recommendation

#### Study limitations

We acknowledge that this study has several limitations. The main limitation in this study was that most of the participants were female and majority of the sample had type of RRMS. Therefore, our results should not be generalized for other types of MS. The other limitation is that the data were collected using self-reported measures and participants may underestimate or overestimate their beliefs and behavior in self-reported questionnaires. To improve generalizability, it is recommended that future studies include other MS types, increasing the number of males, and people with different levels of disability.

Replicating this study among individuals with MS in other languages and cultures is also recommended. Despite those limitations, the results of our study provided sufficient evidence of validity and reliability for EXSE scale in people with MS and support the utilization of instrument as robust measure to evaluate exercise self-efficacy.

### Conclusions

Our study results provide psychometric evidence for a robust measure to evaluate exercise self-efficacy in

people with MS. This measure can utilize by researchers and health-care providers in studies and clinical practice as a valid and reliable measure to assess exercise self-efficacy in people with MS.

### Acknowledgments

The authors thank the participants who took their time to participate in the study. They also thank Tehran University of Medical Sciences for approving the study (IR.TUMS.REC.1395.2280).

### Financial support and sponsorship

Nil.

### Conflicts of interest

There are no conflicts of interest.

### References

- Pearson M, Dieberg G, Smart N. Exercise as a therapy for improvement of walking ability in adults with multiple sclerosis: A meta-analysis. *Arch Phys Med Rehabil* 2015;96:1339-48.e7.
- Criste G, Trapp B, Dutta R. Axonal loss in multiple sclerosis. Causes and mechanisms. In: *Handbook of Clinical Neurology*. New York: Elsevier; 2014. p. 101-13.
- Pilutti LA, Platta ME, Motl RW, Latimer-Cheung AE. The safety of exercise training in multiple sclerosis: A systematic review. *J Neurol Sci* 2014;343:3-7.
- Frohman TC, Castro W, Shah A, Courtney A, Ortstadt J, Davis SL, et al. Symptomatic therapy in multiple sclerosis. *Ther Adv Neurol Disord* 2011;4:83-98.
- Halabchi F, Alizadeh Z, Sahraian MA, Abolhasani M. Exercise prescription for patients with multiple sclerosis; potential benefits and practical recommendations. *BMC Neurol* 2017;17:1-11.
- Latimer-Cheung AE, Pilutti LA, Hicks AL, Martin Ginis KA, Fenuta AM, MacKibbin KA, et al. Effects of exercise training on fitness, mobility, fatigue, and health-related quality of life among adults with multiple sclerosis: A systematic review to inform guideline development. *Arch Phys Med Rehabil* 2013;94:1800-28.e3.
- Suh Y, Joshi I, Olsen C, Motl RW. Social cognitive predictors of physical activity in relapsing-remitting multiple sclerosis. *Int J Behav Med* 2014;21:891-8.
- Klaren RE, Sasaki JE, McAuley E, Motl RW. Patterns and predictors of change in moderate-to-vigorous physical activity over time in multiple sclerosis. *Phys Act Heal* 2017;14:183-8.
- Motl RW, Arnett PA, Smith MM, Barwick FH, Ahlstrom B, Stover EJ. Worsening of symptoms is associated with lower physical activity levels in individuals with multiple sclerosis. *Mult Scler* 2008;14:140-2.
- Motl RW, Sandroff BM. Benefits of exercise training in multiple sclerosis. *Curr Neurol Neurosci Rep* 2015;15:1-9.
- Motl RW, McAuley E, Sandroff BM, Hubbard EA. Descriptive epidemiology of physical activity rates in multiple sclerosis. *Acta Neurol Scand* 2015;131:422-5.
- Klaren RE, Motl RW, Dlugonski D, Sandroff BM, Pilutti LA. Objectively quantified physical activity in persons with multiple sclerosis. *Arch Phys Med Rehabil* 2013;94:2342-8.
- Streber R, Peters S, Pfeifer K. Systematic review of correlates and determinants of physical activity in persons with multiple sclerosis. *Arch Phys Med Rehabil* 2016;97:633-45.e29.
- Casey B, Coote S, Shirazipour C, Hannigan A, Motl R, Martin Ginis K, et al. Modifiable psychosocial constructs

- associated with physical activity participation in people with multiple sclerosis: A systematic review and meta-analysis. *Arch Phys Med Rehabil* 2017;98:1453-75.
15. Bandura A. Health promotion by social cognitive means. *Heal Educ Behav* 2004;31:143-64.
  16. Motl RW, Pekmezi D, Wingo BC. Promotion of physical activity and exercise in multiple sclerosis: Importance of behavioral science and theory. *Mult Scler J Exp Transl Clin* 2018; 4:1-8.
  17. Sharma M, Romas J. *Theoretical Foundations of Health Education and Health Promotion*. 2<sup>nd</sup> ed. Sudbury: Jones & Bartlett Learning; 2012.
  18. Bandura A. *Self-Efficacy: The Exercise of Control*. New York: NY: WH Freeman and Company; 1997.
  19. McAuley E. The role of efficacy cognitions in the prediction of exercise behavior in middle-aged adults. *Behav Med* 1992;15:65-88.
  20. Motl RW, McAuley E, Snook EM. Physical activity and quality of life in multiple sclerosis: Possible roles of social support, self-efficacy, and functional limitations. *Rehabil Psychol* 2007;52:143-51.
  21. Resnick B, Jenkins LS. Testing the reliability and validity of the self-efficacy for exercise scale. *Nurs Res* 2000;49:154-9.
  22. Resnick B, Luisi D, Vogel A, Junaleepa P. Reliability and validity of the self-efficacy for exercise and outcome expectations for exercise scales with minority older adults. *Nurs Meas* 2004;12:235-47.
  23. Dustin I, Resnick B, Galik E, Klinedinst NJ, Michael K, Wiggs E. Reliability and validity of the self-efficacy for exercise in epilepsy and the outcome expectations for exercise in epilepsy scales. *Nurs Meas* 2017;25:22-40.
  24. Shaughnessy M, Resnick BM, Macko RF. Reliability and validity testing of the short self-efficacy and outcome expectation for exercise scales in stroke survivors. *J Stroke Cerebrovasc Dis* 2004;13:214-9.
  25. Everitt BS. *Multivariate analysis: The need for data, and other problems*. *Br J Psychiatry* 1975;126:237-40.
  26. Godin G. The Godin-Shephard Leisure-Time Physical Activity Questionnaire. *Health and Fitness Journal of Canada* 2011; 4:8-22.
  27. Sikes EM, Richardson EV, Cederberg KJ, Sasaki JE, Sandroff BM, Motl RW. Use of the Godin leisure-time exercise questionnaire in multiple sclerosis research: A comprehensive narrative review. *Disabil Rehabil* 2019;41:1243-67.
  28. Tabachnick BF. *Using Multivariate Statistics*. 6<sup>th</sup> ed. Boston: Pearson; 2013.
  29. Weston R, Gore PA, Chan F, Catalano D. An Introduction to using structural equation models in rehabilitation psychology. *Rehabil Psychol* 2008;53:340-56.
  30. Fornell C, Larcker DF. Evaluating structural equation models with unobservable variables and measurement error. *J Mark Res* This 2016;18:39-50.
  31. Cohen J. *Statistical Power Analysis for the Behavioral Sciences*. 2<sup>nd</sup> ed. New Jersey: Lawrence Erlbaum; 1988.
  32. Nunnally J, Bernstein I. *Psychometric Theory*. 3<sup>rd</sup> ed. New York: McGraw-Hill; 1994.