

Distinct Regions Control Transcriptional Activation of the $\alpha 1(\text{VI})$ Collagen Promoter in Different Tissues of Transgenic Mice

Paola Braghetta, Carla Fabbro, Stefano Piccolo, Donatella Marvulli, Paolo Bonaldo, Dino Volpin, and Giorgio M. Bressan

Institute of Histology and Embryology, University of Padova, 35100 Padova, Italy

Abstract. To identify regions involved in tissue specific regulation of transcription of the $\alpha 1(\text{VI})$ collagen chain, transgenic mice were generated carrying various portions of the gene's 5'-flanking sequence fused to the *E. coli* β -galactosidase gene. Analysis of the transgene expression pattern by X-gal staining of embryos revealed that: (a) The proximal 0.6 kb of promoter sequence activated transcription in mesenchymal cells at sites of insertion of superficial muscular aponeurosis into the skin; tendons were also faintly positive. (b) The region between -4.0 and -5.4 kb from the transcription start site was required for activation of the transgene in nerves. It also drove expression in joints, in intervertebral disks, and in subepidermal and vibrissae mesenchyme. (c) The fragment comprised within -6.2 and -7.5 kb was necessary for high level transcription in skeletal muscle and meninges. Positive cells in muscle were mostly mononuclear and probably included connective tissue elements, although staining of myoblasts was not ruled out. This fragment also activated

expression in joints, in intervertebral disks, and in subepidermal and vibrissae mesenchyme. (d) β -Galactosidase staining in vibrissae induced by the sequences -4.0 to -5.4 and -6.2 to -7.5 was not coincident: with the latter sequence labeled nuclei were found mainly in the ventral and posterior quadrant, and, histologically, in the outer layers of mesenchyme surrounding and between the follicles, whereas with the former the remaining quadrants were positive and expressing cells were mostly in the inner layers of the dermal sheath. (e) Other tissues, notably lung, adrenal gland, digestive tract, which produce high amounts of collagen type VI, did not stain for β -galactosidase. (f) Central nervous system and retina, in which the endogenous gene is inactive, expressed the lacZ transgene in most lines. The data suggest that transcription of $\alpha 1(\text{VI})$ in different tissues is regulated by distinct sequence elements in a modular arrangement, a mechanism which confers high flexibility in the temporal and spatial pattern of expression during development.

MOST cells of complex organisms are in permanent contact with the extracellular matrix (ECM)¹, an ordered architecture of macromolecules composed of a variety of secreted proteins and polysaccharides. The ECM is the major determinant of the mechanical properties of organs and contributes to the maintenance of tissue homeostasis. It has been demonstrated in the recent years that several components of the ECM interact with specific cell surface receptors and that this binding triggers rearrangements of the cytoskeleton and intracellular signal transduction cascades leading to changes in cell shape and adhesion, proliferation, gene expression, and differentiation (Juliano and Haskill, 1993). A major

feature of the ECM is the preferred distribution of its components in different tissues and the peculiar variation of their expression during development (Adams and Watt, 1993). Thus, in the embryo, the ECM can be considered as an array of signaling molecules which come in contact with distinct cell populations in a highly regulated manner and influence differentiation and morphogenesis (Lin and Bissel, 1993). Several experiments in various vertebrate species and gene knock out of integrin receptors in the mouse support this view (DeSimone, 1994).

The above considerations point out that a key question in the study of the different components of the ECM is how expression is regulated during development *in vivo*. Despite the very high number of ECM genes identified so far, data on their *in vivo* regulation are limited mostly to collagen type I (Pavlin et al., 1992; Liska et al., 1994; Rosser et al., 1995; Sokolov et al., 1995; references cited in these papers) and type II (Lovell-Badge et al., 1987; Horton et al., 1987). In this report we extend this type of information to type VI collagen. This protein, a trimer of three

Address all correspondence to G. Bressan, Institute of Histology and Embryology, University of Padova, Via Trieste, 75, 35100 Padova, Italy. Tel.: 39 49 827 6086. Fax: 39 49 827 6079. E-mail: bressan@civ.bio.unipd.it

1. *Abbreviations used in this paper:* ECM, extracellular matrix; SMAS, superficial and muscular aponeurotic system.

different chains identified as $\alpha 1(\text{VI})$, $\alpha 2(\text{VI})$, and $\alpha 3(\text{VI})$, has a short collagenous domain flanked at both sides by a large globular domain composed of numerous von Willebrand factor type A repeats (Colombatti et al., 1993).

Collagen VI is adhesive for several cell types and interacts with a number of other extracellular molecules, like collagen type I, II, and III, biglycan, decorin, and hyaluronan (Bonaldo et al., 1990; Bidanset et al., 1992; Colombatti et al., 1993; Pfaff et al., 1993; Specks et al., 1992), a property suggesting that the protein contributes to the ordered organization of the ECM. In the matrix, type VI collagen forms a network of microfibrillar aggregates distinct from, but often mixed with the banded fibers of type I collagen (Bruns et al., 1986). Although the distribution of the two collagen types is widely overlapping, important differences have been described, including a high ratio of type VI to type I collagen in intervertebral disks and articular cartilage, and an opposite proportion in bone and a preferred localization of type VI collagen in the pericellular space or underneath epithelial cell layers (Keene et al., 1988; Marvulli et al., 1996). These differences may be important for conferring peculiar mechanical properties not only to the various tissues, but also to distinct regions within the same tissue. An interesting difference between the two collagen types has also been revealed by studies on the *in vitro* differentiation of several cells of mesodermal origin, like adipocytes, myoblasts, and chondroblasts: collagen VI, but not I, is transiently expressed at very high levels during the initial phase of differentiation (Dani et al., 1989; Ibrahim et al., 1993; Quarto et al., 1993; Piccolo et al., 1995). To clarify the mechanisms responsible for tissue specific transcription of collagen type VI, we have undertaken the analysis of *cis*-acting elements of the $\alpha 1(\text{VI})$ chain gene *in vivo*. In this study we have identified genomic regions necessary for high level activation in several tissues.

Materials and Methods

DNA Constructs

The isolation and characterization of a λ clone (mG1) for the mouse $\alpha 1(\text{VI})$ collagen gene has been described (Bonaldo et al., 1993). Two fragments of mG1 subcloned into the plasmid Bluescript (Stratagene, La Jolla, CA) were the starting material for the synthesis of the constructs used in this study. One SphI fragment contained ~ 7.5 kb of the 5'-flanking sequence of the gene, the first two exons, the first and part of the second intron, and included a PstI fragment extending from base +41 to base -1344 from the transcription start site (Bonaldo et al., 1993). For synthesis of p1.4lacZ, the 1.4-kb PstI fragment was inserted into the PstI site of pNSlacZ, a vector which contains the *E. coli* β -galactosidase gene preceded by the nuclear localization signal and followed by the polyadenylation site of SV40 large T antigen between the PstI and BamHI sites of pKS-Bluescript. A fragment extending from +75 to -635 was derived from the genomic clone by PCR amplification, restriction at the internal PstI site, and insertion into pNSlacZ, producing plasmids p0.6lacZ. To construct p7.5 Δ (3.0-1.1)lacZ, the fragment extending from -7.5 to -3.0 kb was excised from the SphI subclone by cutting with NotI (in the polylinker) and NsiI and inserted into p1.4lacZ after removal of the sequence upstream of the NsiI site at -1111 with the same enzymes. The NsiI fragment from -3.0 kb to base -1111 was then inserted into the NsiI site of p7.5 Δ (3.0-1.1)lacZ to give plasmid p7.5lacZ. Constructs p6.2lacZ, p5.4lacZ, p4.0lacZ, and p2.8lacZ were derived by deleting 5' portions of p7.5lacZ with restriction enzymes HindIII, BamHI, SmaI, and DraI, respectively (Fig. 1 A). Plasmids p7.5 Δ (6.2-1.4)lacZ, p6.2 Δ (5.4-1.4)lacZ, and p5.4 Δ (4.0-1.4)lacZ (Fig. 1 B) were obtained by subcloning the appropriate restriction fragment in vector p1.4lacZ upstream of the proximal 1.4 promoter region.

Production and Identification of Transgenic Mice

Transgenic mouse lines and embryos were produced from B6D2F1 females mated with B6D2F1 males (Charles River Italia or MBS, Treviso, Italy) using standard procedures (Hogan et al., 1986). DNA was microinjected into pronuclei of one-cell embryos and the surviving embryos were implanted into CD1 pseudopregnant foster mothers. Transgenic mice were identified by analysis of genomic DNA from yolk sac or tail biopsies by either PCR using appropriate primers and reaction conditions or the dot blot assay. The number of integrated transgene copies of the lines was determined by Southern blot analysis using an internal fragment of lacZ as probe. To analyze the temporal and spatial pattern of β -galactosidase expression in the established lines, founder or F1-males were mated with B6D2F1 females and embryos isolated at different days of gestation. The day of the vaginal plug was designated day 0.5 of gestation. When the founder embryos were sacrificed the age was confirmed by staging (Butler and Juurlink, 1987).

Whole Mount LacZ Staining and Histological Analysis

Embryos were dissected, quickly washed in PBS, and processed for fixation and histochemical staining for β -galactosidase exactly as described (Bonnerot and Nicolas, 1993). The dorsal part of 14.5 d and older embryos was cut with a razor blade on a midsagittal plane in order to facilitate penetration of fixative and staining solutions. After overnight incubation at 30°C in the staining solution, positive embryos were washed in PBS, photographed, fixed for 12–16 h in 4% paraformaldehyde in PBS, dehydrated in ethanol, and embedded in paraffin. 6–10- μm thick sections were mounted on gelatinized glass slides, counterstained with hematoxylin and eosin and mounted in Permount. All the pictures shown in this paper were from embryos excepting Figs. 4 C and 9 E, which were from the leg of an adult transgenic mouse. In this case the limb was disarticulated at the coxo-femoral joint and processed for X-gal staining after removal of the skin. The samples were then demineralized in 4% formic acid for one week and embedded in paraffin.

LacZ Staining and Immunofluorescence of Frozen Sections

Embryos were dissected in PBS and the left upper limb was cut out and individually processed for lacZ staining as described above. The rest of the embryo was frozen in isopentane cooled in liquid nitrogen and kept at -80°C. Transgenic embryos were identified the following day by inspection of the limbs. 6–10- μm cryostat sections were collected on gelatin-coated glass slides and air dried. For staining, the sections were fixed for 30 s in acetone, air dried, and incubated overnight in X-gal solution (Bonnerot and Nicolas, 1993) at room temperature. After washing in PBS, the slides were counterstained with hematoxylin and eosin and mounted in 50% glycerol in PBS. In some experiments sections stained for β -galactosidase were treated with the mouse monoclonal antibody iC8 (Vitadello and Denis-Donini, 1990) which recognizes the NF-M subunit of mouse neurofilaments and/or a rabbit polyclonal antibody specific for mouse type VI collagen (Colombatti et al., 1995). The slides were then incubated with rhodamine-labeled goat anti-mouse Ig and/or fluorescein-labeled goat anti-rabbit Ig, washed, stained with HOECHST dye, mounted in 50% glycerol in PBS and observed in a Zeiss Axioplan microscope equipped with epifluorescence optics.

Results

Generation of Transgenic Mice

Transgenic mice were generated with β -galactosidase constructs comprising various portions of the 5'-flanking region of the $\alpha 1(\text{VI})$ collagen gene. For initial investigation of the pattern of promoter expression, a total of 34 independent expressing lines were generated using the constructs shown in Fig. 1 A. For most lines the founder was sacrificed; however, four lines with the longest and one with the shortest construct were propagated, allowing analysis of transgene expression at different developmental ages. No variations in the pattern and the intensity of

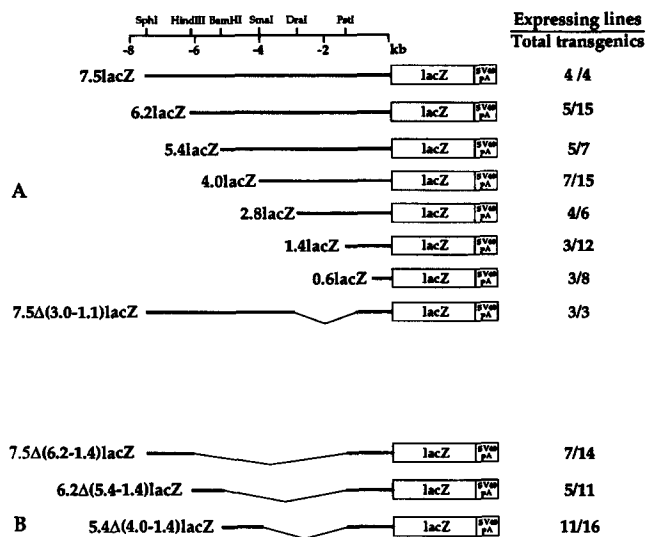

Figure 1. Constructs used and transgenic animals generated. Different portions of the 5'-flanking region of the $\alpha 1(VI)$ collagen chain were fused with the *E. coli* β -galactosidase gene followed by the polyadenylation signal of SV40. (A and B) Constructs used to generate transgenic animals analyzed in Table I and Table II, respectively.

transgene expression were observed in different embryos of the same established line. At least three lines were produced for each construct and, in each group, at least one line had multiple copies of the transgene (Table I).

Expression of Transgenes

Embryos were whole mount-stained and examined. Serial sections were then prepared from each of them and observed in the microscope. For established transgenic lines, cryostat sections were also prepared and subsequently stained for β -galactosidase. Similar results were obtained with the two procedures. The main distribution of β -galactosidase-producing cells in tissues from the different lines is summarized in Table I in parallel with the evaluation of collagen VI expression products in control embryos at different locations (Marvulli et al., 1996). Four major categories of tissues could be distinguished. In some tissues in which the synthesis of type VI collagen is very active, a particular construct was usually expressed or not expressed depending on the size of the promoter fragment. These tissues included skin insertions of superficial aponeurosis, joints, intervertebral disks, nerves, vibrissae, skeletal muscle, and meninges where expression was high, and tendons and subepidermal mesenchyme where the levels of activity of the reporter gene were usually weak. Expression in these tissues is described below in detail and is summarized in Table I. In a second group of tissues, β -galactosidase staining was negative in most transgenic animals, although varying amounts of products (mRNA and protein) of the endogenous gene could be demonstrated in their connective tissue. This condition was detected in lung, digestive tract and associated glands, thymus, bladder, kidney, serosae, adrenal gland, gonads, periosteum, and perichondrium. Examples of the absence of staining in these tissues can be found in Fig. 5, D and E for stomach, adre-

nal gland, kidney and lung, and in Fig. 6 C for gonads and liver. Due to the absence of staining, these organs have not been considered in Table I. A third group comprised of tissues such as the central nervous system and the retina, which are not collagen VI producers, but which exhibited ectopic expression of the transgenes in almost every line or embryo investigated. A summary of this ectopic staining has been reported in Table I. Finally, some collagen VI-producing tissues randomly expressed the transgenes only in a limited set of lines (<20% of total) at low levels and with no apparent correlation with the size of the promoter sequence of the construct. Examples were heart, blood vessels, adipose tissue, and cartilage. Although not completely negative, the low expression of the transgenes in these tissues did not allow a clear analysis of the regulatory regions. These tissues were therefore not included in Table I.

In the following description of β -galactosidase expression in different tissues the emphasis will be on tissues of the first group. The pattern of expression in this group depended on the size of the regulatory region of the transgene. As this was increased, staining was found at additional sites, in such a way that tissues positive in transgenic mice with shorter constructs were usually a subgroup of those positive in animals with longer constructs (Table I). Overall, there was a remarkable similarity in the pattern of expression of β -galactosidase in lines with the same promoter construct. Variations were, however, observed in the levels of transgene expression between the lines, as estimated by the relative number of X-gal positive nuclei in a given tissue (Table I). These differences were apparently not related to the transgene copy number and are likely a consequence of the site of DNA integration.

Sites of Insertion of the Superficial Muscular and Aponeurotic System. Constructs with a 5'-flanking region equal to or shorter than 4.0 kb (0.6lacZ, 1.4lacZ, 2.8lacZ and 4.0lacZ) gave very similar results (Table I and Fig. 2). In embryos of the line 0.6lacZ57, β -galactosidase reaction was detectable starting at 12.5 d as a ring in the limb buds, which was stronger in the forelimb (Fig. 2 A). Discrete areas of staining were also noted just in front of the ear (Fig. 2 A) and at the armpit and the groin (Fig. 2 B). Staining increased in intensity in the following days and, at 16.5 d, it was restricted to the forearm in the upper limb (Fig. 2 C), whereas, in the lower limb, it became a patch with posterior location (Fig. 2 D). Embryos transgenic for the 1.4lacZ, 2.8lacZ, and 4.0lacZ constructs produced a similar staining. Examples for 1.4lacZ and 2.8lacZ are shown in the Fig. 2, E and F. The former was identical to the 0.6lacZ line. The latter had a very strong reactivity in the ear region and, in addition, in the upper and lower eyelids. The staining pattern described above was common to all the transgenic embryos examined and examples with longer constructs can be seen in Figs. 3, 5 A, and 6 B. Microscopic examination revealed that all these positive, apparently unrelated, regions had a common histological motif, since they represented sites of insertion of the superficial aponeurosis which contains the cutaneous muscle (Fig. 3). As explained in the Discussion, this tissue has been indicated in this study as the Superficial and Muscular Aponeurotic System (SMAS). The association of the $\alpha 1(VI)$ transgenes expression with this structure is clearly seen in the parasag-

Table I. Main Tissue Distribution of Transgene Expression*

Line	Copy number	Age of embryos (d)	Tissues									
			Insertion of superficial aponeuroses	Tendons and ligaments	Joints	Intervertebral disks	Nerves	Subepidermal mesenchyme	Vibrissae (mesenchyme)	Skeletal muscle	Meninges	CNS [§] and/or retina
0.6lacZ57	1	13.5; 16.5	++	+	-	-	-	-	-	-	-	++
0.6lacZ2	13	15.5	+	±	-	-	-	-	-	-	-	-
0.6lacZ3	8	15.5	+++	+++	-	-	-	-	-	+	-	+
1.4lacZ1	ND	15.5	++	+	-	-	-	-	-	-	-	+
1.4lacZ2	ND	14.5	++	+++	-	-	-	-	-	-	-	++++
1.4lacZ3	5	15.5	++	±	-	-	-	-	-	-	-	+
2.8lacZ1	3	15.5	+++	++	-	-	-	-	+	-	-	+++
2.8lacZ2	1	15.5	+	++	-	-	-	-	-	-	-	+++
2.8lacZ3	1	14.5	++	+++	-	-	-	-	-	-	++	+
2.8lacZ4	1	14.5	++	+	-	-	-	-	-	-	-	+
4.0lacZ1	1	15.5	++	++	-	-	-	-	-	-	-	++
4.0lacZ2	1	15.5	+	±	-	-	-	-	-	-	-	+++
4.0lacZ3	8	15.5	++	±	-	-	-	-	+	-	-	++
4.0lacZ4	1	15.5	+	±	-	-	-	-	-	-	-	+++
4.0lacZ5	3	15.5	++	±	-	-	-	-	-	-	-	-
4.0lacZ6	1	15.5	+++	++	-	-	-	-	-	-	-	+
4.0lacZ7	1	14.5	++	+	-	-	-	-	-	+	-	++
5.4lacZ1	12	15.5	++++	++	±	±	++++	+	++++	±	+++	+++
5.4lacZ2	5	15.5	+	±	+++	++	+	±	±	-	-	+
5.4lacZ3	4	15.5	+++	+	++++	++++	++++	+	++++	-	-	+
5.4lacZ4	8	15.5	+++	+	++	++	++	+	+	-	-	++
5.4lacZ5	1	14.5	+	+	±	+	+	±	±	-	-	++
6.2lacZ1	4	14.5	++++	+	++	+++	++++	++	+++	-	-	+++
6.2lacZ2	1	14.5	++++	+++	++	+	±	±	±	+	-	++++
6.2lacZ3	1	15.5	++++	+	++	++	+++	±	+++	-	-	++
6.2lacZ4	1	15.5	++++	+	++	++	+++	±	+++	-	-	+
6.2lacZ5	1	15.5	++	++	+	+	+++	±	+	±	-	+++
7.5Δ(3.0-1.1)lacZ1	3	15.5	++++	+++	++++	++++	+++	+	+++	+++	+	++
7.5Δ(3.0-1.1)lacZ2	5	14.5	++++	++	++	++++	++++	+	++++	+	+	++++
7.5Δ(3.0-1.1)lacZ3	3	14.5	++++	+++	+++	++++	++++	+	++++	+	++++	++++
7.5lacZ8	4	9.5 to 16.5	+++	++	++++	++++	++++	+++	++++	+++	+++	+++
7.5lacZ57	6	12.5 to 16.5	+++	++	+	+	±	±	+	+	++	+++
7.5lacZ62	4	11.5 to 16.5	+++	+	++++	++++	+++	++	++++	++	+++	++
7.5lacZ71	6	9.5 to 16.5	++	++	+++	+++	+	±	+++	++	++	+++
Control [¶]		9.5 to 16.5	++++	+++	++++	++++	+++	++++	++++	++++	+++	-

*Intensity of β-galactosidase staining in each of the 34 lines was evaluated by examination of serial sections from whole mount stained embryos with the following arbitrary scale of stained nuclei: -, no labeled nuclei; ±, rare labeled nuclei at only a few locations; +, a few labeled nuclei at multiple locations or numerous labeled nuclei at a few locations; ++, numerous labeled nuclei at multiple locations or a few labeled nuclei at most locations or most nuclei labeled at a few locations; +++, most nuclei labeled at multiple locations or numerous nuclei at most locations; +++++, most nuclei labeled at most locations. For most lines, the founder was sacrificed at the indicated embryonic age.

[§]CNS, central nervous system.

^{||}The founder was sacrificed at the indicated embryonic age.

[¶]Determined by immunohistochemistry and in situ hybridization experiments (Marvulli et al., 1996). Arbitrary scale from no (-) to very intense (+++++) staining.

ittal section of the hindlimb of Fig. 3 A, where the SMAS (arrows) inserted into the skin. At the insertion sites, mesenchymal cells accumulated very close to the epithelium and fibrillar structures from the connective tissue surrounding the superficial fascia converged toward them (Fig. 3 B). A similar picture was detected in the armpit (Fig. 3 C), and, in some embryos, in the eyelids (Fig. 3 D). We interpret the latter localization as the site of anchorage of the palpebral connective tissue which envelops the orbicular ocular muscle to the conjunctiva and the skin of

eyelids. An interesting detail of Fig. 3 D is that the cutaneous muscle converges toward the X-gal stained structures. The same organization was found in the region in front of the ear (Fig. 3 E). In this case, however, β-galactosidase staining accumulated where the superficial aponeurosis, rich in muscle fibers, intersected the ear cartilage. The proposed tissue architecture is illustrated in Fig. 3 F for the skin.

Tendons. Expression of lacZ reporter gene in tendons was detected in all the transgenic lines examined. Tendons

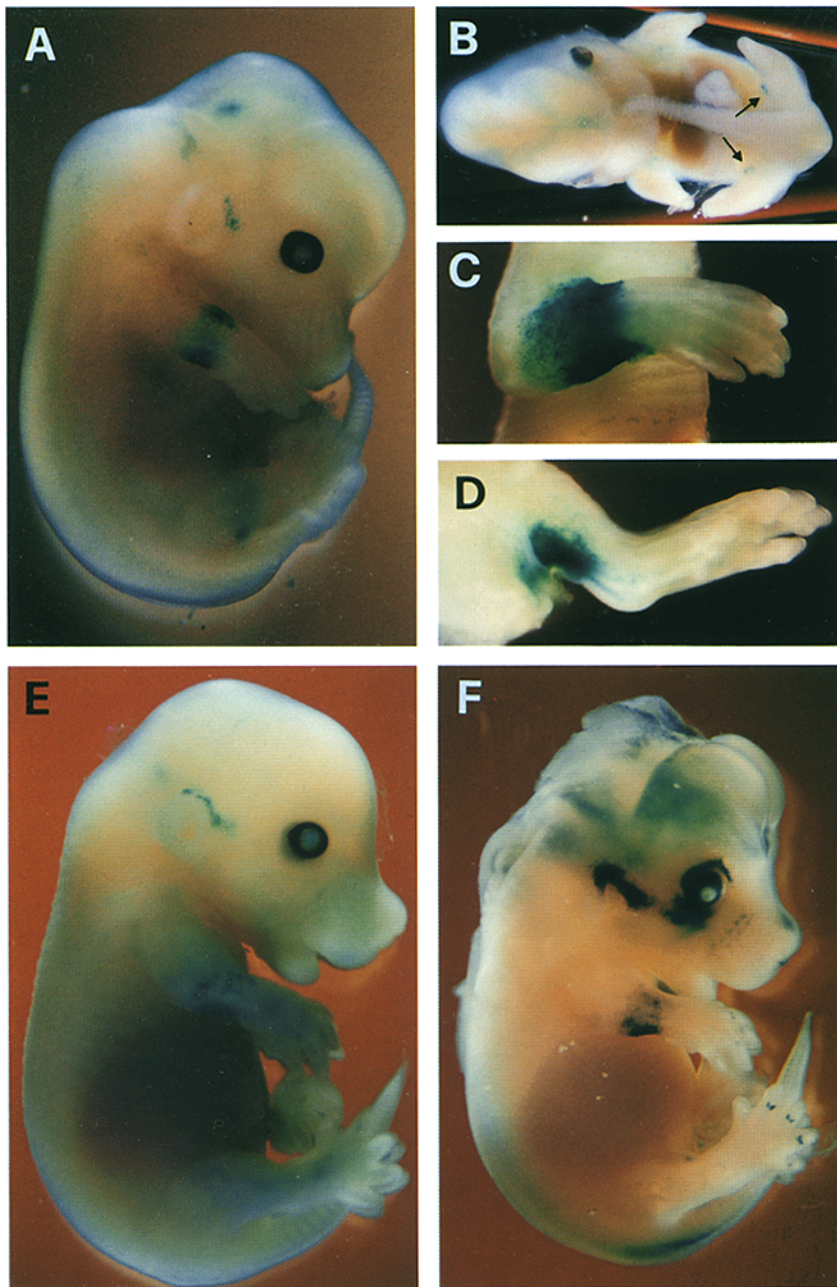

Figure 2. Expression pattern characteristic of transgenes with regulatory sequence shorter than 4.0 kb. Whole mount staining. (A and B) Embryos of line 0.6lacZ57 at 13.5 (A) and 12.5 d (B). (C and D) Upper and lower limbs of an embryo of 16.5 d of the same line. (E) Embryo of line 1.4lacZ1. (F) Embryo 2.8lacZ1. Labeling is found in limbs, in a region in front of the ear and at the internal side of the root of the limbs (B, arrows) in all embryos, and, with lower frequency, in the eyelids (F). The capsules between the first and the second phalanges are also labeled in embryo 2.8lacZ1 (F). Among this group of embryos, staining in phalanges was unique to 2.8lacZ1.

in the tail were among the most reactive (Fig. 4 A) and labeled cells were found throughout their structure (data not shown). In other locations staining was mainly at the periphery of the tendon, in the peritenoneum (Fig. 4 B), and at the bone-tendon junction. This was very clear in sections from adult animals, where the surface of insertion of tendon on bone was larger (Fig. 4 C). All the sites expressing the transgene were strongly stained with antibodies to collagen VI (data not shown).

Joints and Intervertebral Disks. When the 5'-flanking region of the constructs was increased to 5.4-kb or to 6.2-kb, β -galactosidase reaction became detectable in five additional tissues: joints, intervertebral disks, nerves, subepidermal mesenchyme, and vibrissae in all the lines (Table I). These same tissues were positive in all lines with a regulatory sequence extending to -7.5 kb from the transcription

start site [constructs 7.5 Δ (3.0-1.1)lacZ and 7.5lacZ] (Table I) and the data will therefore be presented in the same figures for all these constructs. Stain deposition in joints was particularly strong in articular cartilage of large diarthroses where it was apparent also in whole mount preparations when the superficial tissues were poorly labeled (Fig. 5 A). Only a few cell layers underneath the articular surface were positive, whereas the bulk of cartilage was negative (Fig. 5, B and C). Articular cartilage of small diarthroses was less frequently stained; this happened usually with longer constructs (Fig. 5 D). In transgenic animals carrying the longest regulatory region, the synovial membrane was also stained (Fig. 5 C). Intervertebral disks were among the tissues exhibiting highest reactivity (Fig. 5 E).

Nerves. β -Galactosidase staining associated with nerves was primarily studied in the mouse line 7.5lacZ8, but the

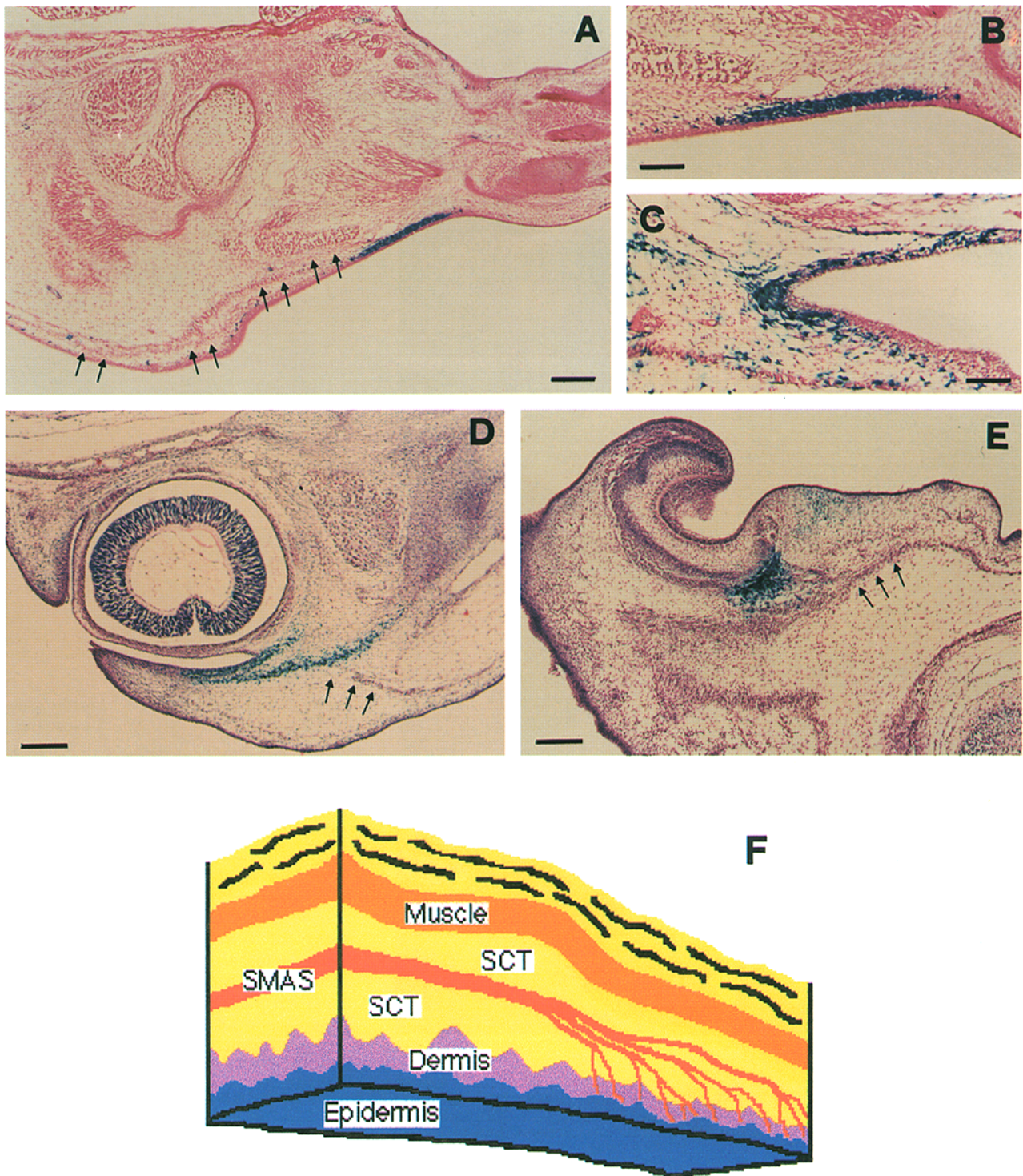

Figure 3. Histological analysis demonstrating expression of transgenes at sites of insertion of the SMAS. (A) Parasagittal section of the left hindlimb of embryo of line 5.4lacZ3 showing insertions of SMAS at the posterior surface of limb; SMAS is indicated by arrows. (B) Enlarged view of the site of insertion shown in A. (C) Armpit of embryo of line 5.4lacZ1. (D) Oblique section through right eye of embryo of line 2.8lacZ1; note that SMAS (arrows) converges toward the β -galactosidase positive region which contacts the basal surface of the epithelium of conjunctiva. (E) Section through right external ear of embryo of line 2.8lacZ1 showing anchoring of SMAS (arrows) to the ear cartilage primordium. (F) Drawing illustrating cutaneous and subcutaneous tissue (SCT) with SMAS and its skin insertion sites. Bars: (A, D, and E) 200 μ m; (B and C) 100 μ m.

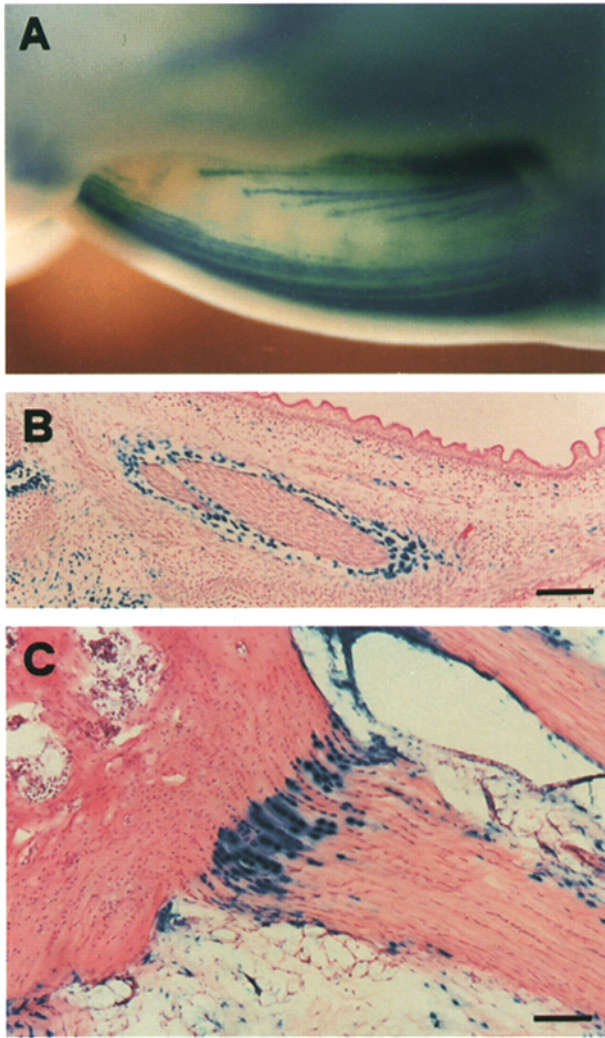

Figure 4. Transgenes expression in tendons. (A) Whole mount staining of embryo of line 6.2lacZ2 showing tendons of the tail. (B) Frozen section of tendon of the right tibialis anterior muscle from a 16.5-d-old embryo of line 7.5lacZ8; blue X-gal reaction products are detectable mainly at the periphery of the tendon and in the peritenoneum. (C) Section of lateral head of gastrocnemius muscle from an adult mouse of the 7.5lacZ8 line. β -Galactosidase staining is particularly intense in tendon cells close to the bone. Bar, 100 μ m.

data were confirmed in all the embryos with constructs including the sequence from -4.0 to -5.4 . Faint labeling was first detectable as scattered groups of cells in the dorsal and lateral body wall and in the proximal part of the upper limb at 11.5 d (data not shown). One day later, the reaction was stronger and appeared as a superficial network which extended ventrally with a sharp border in the body wall, reached the forearm in the upper limb and began to expand into the lower limb (Fig. 6 A). In the following days the network invaded completely the ventral region and propagated to the tip of the fingers (Fig. 6 B). The neck (Fig. 6, A and B) was also stained. In the head, labeling was weaker and was slightly enhanced in the temporal and in the frontal regions (data not shown). The identity of the observed structures as nerves was estab-

lished by histological analysis of serial sections (Fig. 6, C, D, and E). Stained cells sharply delimited the perimeter of monofascicular nerves (Fig. 6 E). Additional information on the location of the labeled cells with respect to the axon bundles was obtained by staining the same cryostat section histochemically for β -galactosidase and immunologically with antibodies specific for neurofilaments and type VI collagen (Fig. 7). Reactive cells were found in contact with axon bundles of different sizes (Fig. 7, A and C). In larger axon associations the cells were almost exclusively detected at the periphery. This is particularly evident in Fig. 7, C, D, and E, which show an oblique section of a nerve: on the left side, where the innermost part of the nerve has been sampled, labeled nuclei border the axon bundle; on the right side, where the section cuts the nerve tangentially, stained nuclei overlap with a region immunofluorescent for neurofilaments and strongly positive for collagen type VI.

Vibrissae and Subepidermal Mesenchyme. Mesenchymal cells surrounding vibrissae were positive in embryos with promoter fragments larger than 4.0 kb (Table I; Figs. 5 A, 6 B, 8 A, and 9 A). In addition, two out of seventeen lines with the promoter region shorter than 4.0 kb also had staining in this tissue (lines 2.8lacZ1 and 4.0lacZ3). It is worth noting that both lines had multiple copies of the transgene. X-gal positive cells were found in the loose connective tissue under the skin. The nature of these cells is unknown and, given their fibroblast-like morphology, they can be generally classified as mesenchymal cells. Staining of this subepidermal mesenchyme was apparent only relatively late (after 14.5–15.5 d of gestation) and was faint in most embryos, excepting those of the 7.5lacZ8 line, in which labeled nuclei were more abundant in the subcutaneous tissue; in the dermis positive cells were often close to hair follicles (Fig. 8 B).

Skeletal Muscle. Transgenic embryos generated with constructs including the entire 7.5-kb of 5'-flanking sequence (7.5lacZ) or a fragment with an internal deletion in the 3' region [7.5 Δ (3.0-1.1)lacZ], expressed β -galactosidase at high levels in the tissues described above (Table I). In addition, positive cells were found in skeletal muscle, particularly in the two lines 7.5lacZ8 and 7.5lacZ62. Very faint staining with a metameric pattern was first detectable in whole mount preparations of 11.5-d embryos in the dorsolateral region (data not shown). At 13.5 d, strongly reactive muscle masses were located in the lateral body wall (Fig. 9 A), in the dorsal region as a long thread bordering the vertebral column (Fig. 9 B), and in the limbs (Fig. 9, A and B). Histological examination revealed that different muscles stained with different intensity (Fig. 9 C and Fig. 6 E). Interestingly, however, the pattern of muscle labeling was similar in the various lines and embryos (compare Fig. 9 C with Fig. 6 C). At high microscopic magnification, it was apparent that β -galactosidase reaction was predominant in mononuclear cells surrounding the muscle fibers (Fig. 9 D). Very often it could not be established if the labeled nuclei belonged to the mononuclear cells or to the myotubes. Thus, we cannot exclude at the moment the possibility that the transgenes were expressed by the muscular elements. X-gal positive nuclei were also detected in adult muscle (Fig. 9 E). Most nuclei were clearly located within the connective tissue; however, some were very flat and closely

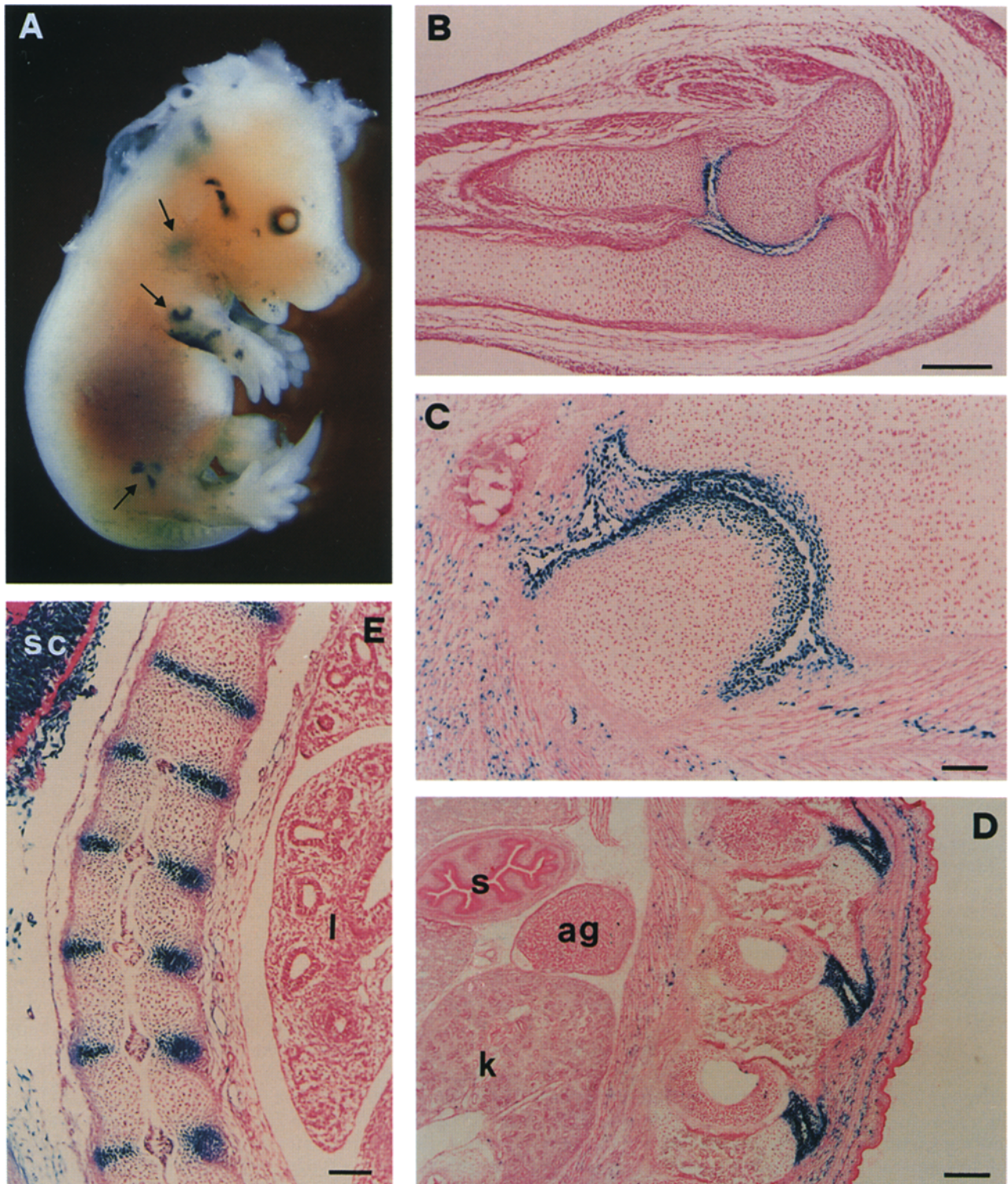

Figure 5. Expression of the lacZ constructs in joints and intervertebral disks. (A) Whole mount preparation of embryo 5.4lacZ4; deposition of X-gal stain in scapulo-humeral, elbow, and knee articulations (arrows) can be seen through the superficial tissues, which contain a faintly positive network. (B) Section of the elbow joint of embryo of line 5.4lacZ2; labeling is mainly located in the articular cartilage. (C) Scapulo-humeral joint from a 16.5-d-old embryo of the line 7.5lacZ8; both articular cartilage and the synovial membrane are positive. (D) Strong staining of intervertebral diarthroses in a 16.5-d embryo of the 7.5lacZ8 line; note absence of labeled nuclei in the kidney (*k*), in the adrenal gland (*ag*), and in the pyloric part of the stomach (*s*). (E) Sagittal section of embryo of line 7.5 Δ (3.0-1.1)lacZ3; the entire intervertebral disks express β -galactosidase; lung (*l*) is negative, whereas spinal cord (*sc*) is darkly stained. Bars: (B and D) 200 μ m; (C and E) 100 μ m.

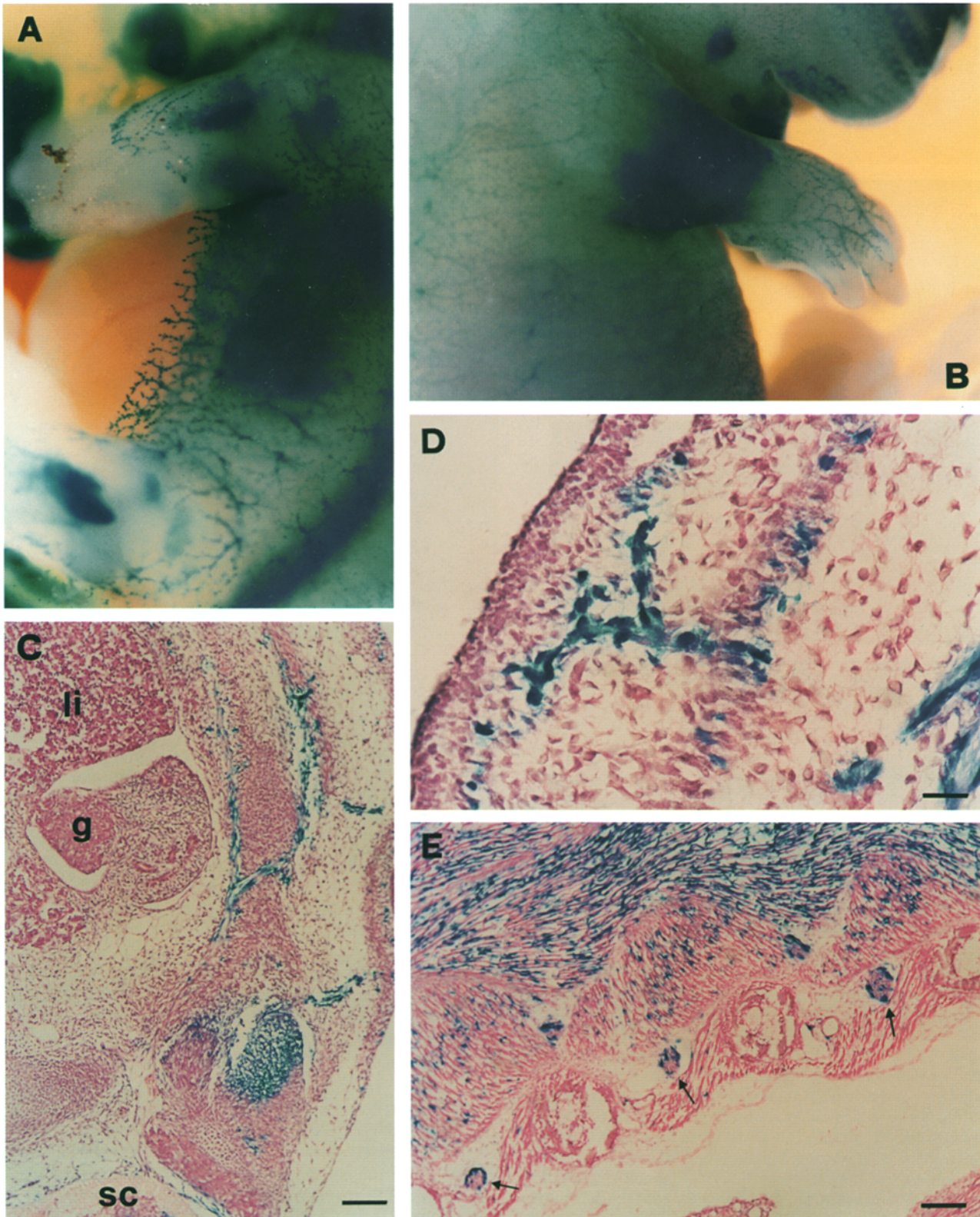

Figure 6. Expression of lacZ transgenes in nerves. (A) Whole mount staining of a 12.5-d embryo of the line 7.5lacZ8. (B) Whole mount preparation of embryo of line 5.4lacZ3 (15.5 d). (C) Cross section of a 13.5-d 7.5lacZ8 embryo; staining is evident in nerve branches of different size; g, gonad; li, liver; sc, spinal chord. (D) Section through superficial tissues of embryo of line 7.5Δ(3.0-1.1)lacZ3. (E) Parasagittal section of a 16.5-d embryo of line 7.5lacZ8; positive cells form an epithelioid layer around intercostal nerves (arrows). Bars: (C and E) 100 μm; (D) 25 μm.

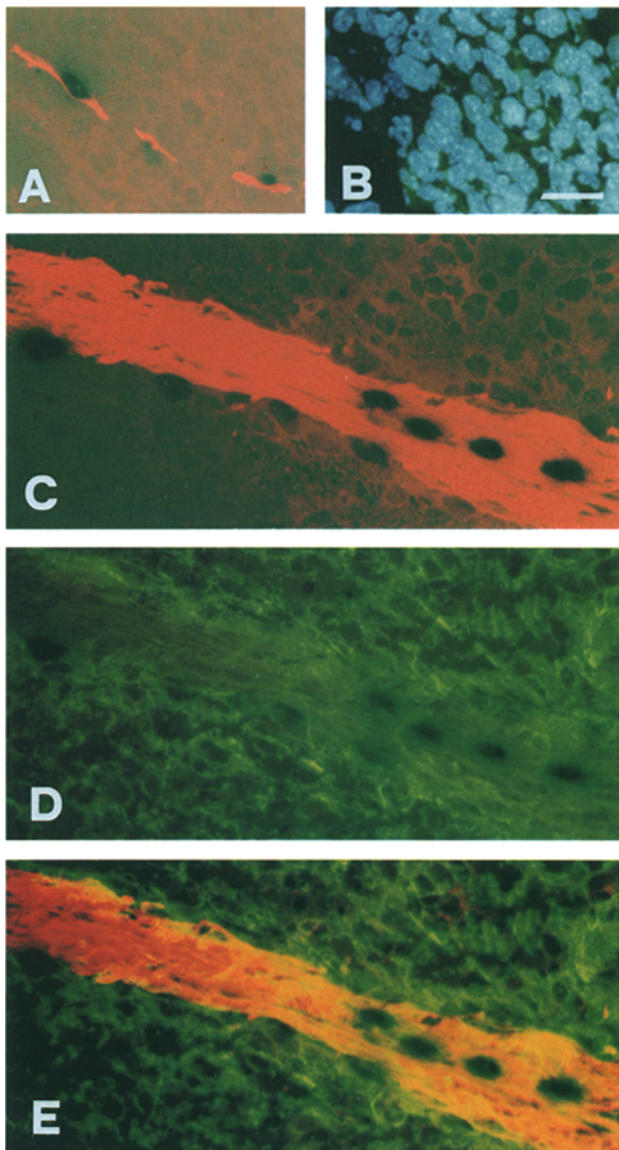

Figure 7. Association of transgene expressing cells with axon bundles. Frozen sections were cut from 14.5-d embryos of the 7.5lacZ8 line and processed for β -galactosidase histochemical reaction. The sections were then stained with a monoclonal antibody against neurofilaments and a rhodaminated secondary antibody, an antibody specific for mouse type VI collagen and a fluoresceinated secondary antibody and with HOECHST dye. *A*, *C*, *D*, and *E* were taken with double exposure of bright field and fluorescence optic. *(A)* A superficial axon bundle (rhodamine stained) of the thoracic wall and associated β -galactosidase positive cells. *(B)* The same field of *A* observed for HOECHST fluorochrome to localize nuclei. *(C)* Distribution of β -galactosidase positive cells in a large axon bundle (rhodamine stained); the cells are observed mainly at the periphery of the nerve. *(D)* The same section of *C* showing the distribution of collagen VI (fluoresceine stained); the protein is abundant around the nerve, but is also detectable in the surrounding connective tissue. *(E)* Same section of *C* and *D* observed under double immunofluorescence; extensive overlapping of staining for neurofilaments and type VI collagen in the right part of the picture is indicated by yellow fluorescence. Bar, 25 μ m.

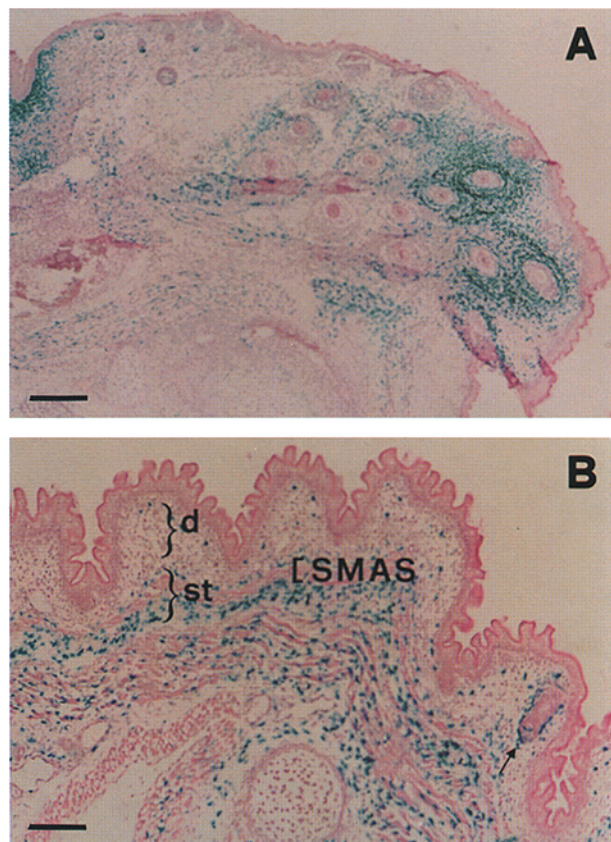

Figure 8. Expression of lacZ gene in mesenchyme of vibrissae (*A*) and in the skin (*B*) in a 16.5-d embryo of the line 7.5lacZ8. The extension of dermis (*d*) and subcutaneous tissue (*st*) are indicated. The subcutaneous tissue is split in a superficial and a deep layer by the presence of the SMAS, in which a thin sheet of cutaneous muscle can be seen. Arrow in *B* points out a hair follicle. Bars: (*A*) 200 μ m; (*B*) 100 μ m.

associated with the myofibers in a way expected for nuclei of the myotubes or of satellite cells. Staining in skeletal muscle was also detected in $\sim 15\%$ of the lines with the promoter fragment not including the region -6.2 to -7.5 (Table I).

Meninges. Lines with a transgene containing the region from -7.5 to -6.2 exhibited expression in meninges. With shorter constructs only two embryos showed labeled meninges, one of which had a high transgene copy number (Table I). An example of labeling of meninges can be seen in Fig. 9 C.

Ectopic Expression. The central nervous system and/or the retina, which are not collagen VI producers, were reactive for β -galactosidase in 32 out of 34 transgenic lines (Table I). In the central nervous system staining was usually detected in the telencephalon and in the spinal cord. Examples of staining in the central nervous system and retina can be found in Figs. 2 A, E, F, 5 E, 9, A and B.

Further Analysis of the Promoter Region from -4.0 to -7.5

The data reported above suggest that the 7.5-kb fragment flanking the 5' end of the $\alpha 1(\text{VI})$ gene contains positive-acting elements which stimulate high level transcription in

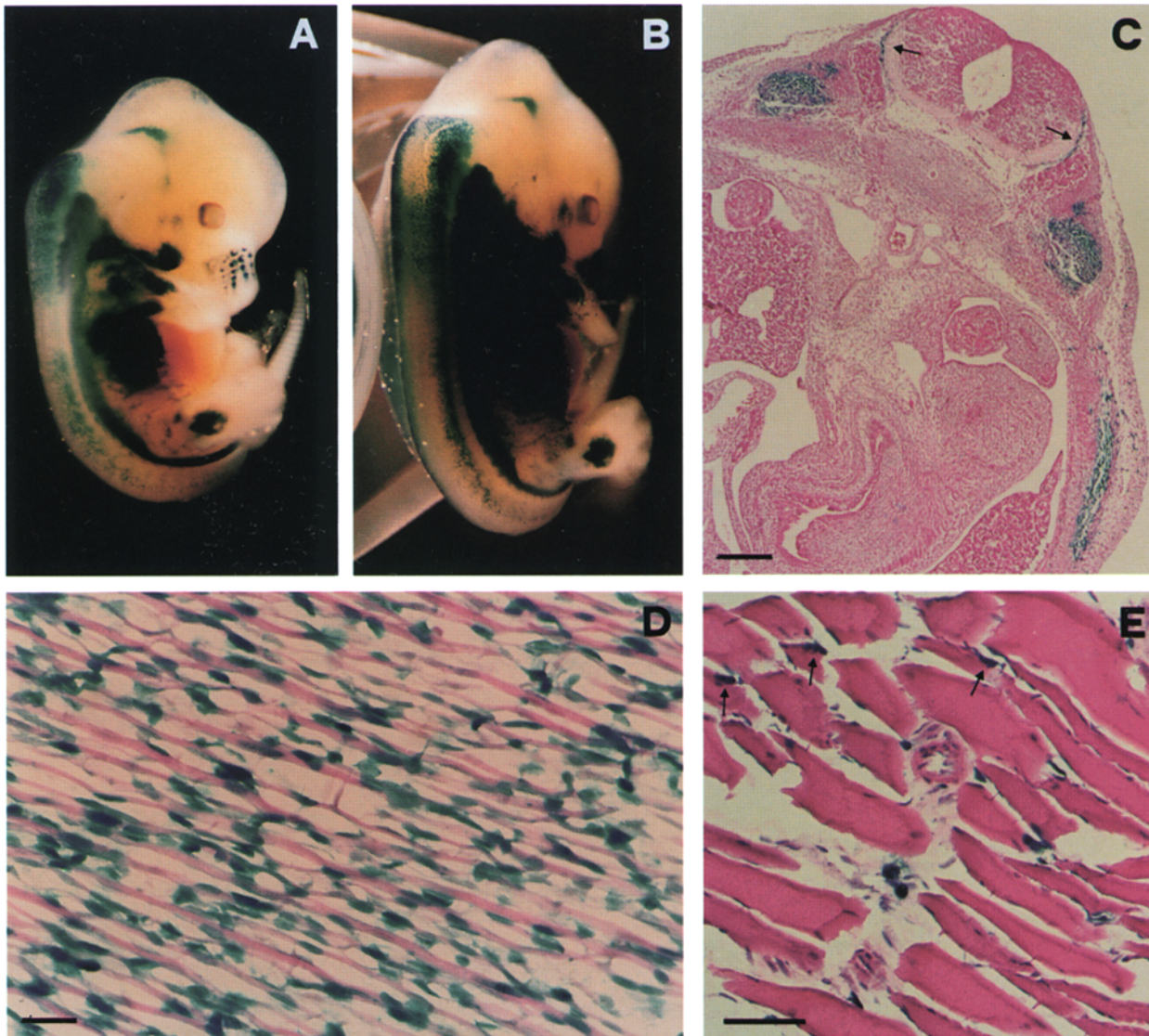

Figure 9. Expression of transgenes in skeletal muscle. (A and B) Lateral and back view of a 13.5-d embryo from the line 7.5lacZ62. (C) Histological section showing that the deep blue staining of embryo in A and B is located in skeletal muscles; meninges (arrow) are also labeled. (D) Frozen section from 16.5-d embryo of line 7.5lacZ8. (E) Muscle from an adult mouse; several X-gal labeled nuclei belong to connective tissue cells; some are very flat and closely associated with the myotubes as expected for nuclei of muscle fibers or of satellite cells (arrows). Bars: (C) 200 μ m; (D) 25 μ m; (E) 50 μ m.

nine tissues where type VI collagen is normally expressed, including insertion of superficial aponeurosis, tendons, joints, intervertebral disks, nerves, subepidermal mesenchyme, vibrissae, skeletal muscle, and meninges. Excepting the first two, the elements for the other seven tissues are apparently located in the region -4.0 to -7.5 . The analysis of Table I, however, does not tell us if different portions of this large region are equally effective as inducers. In addition, for some other tissues, notably skeletal muscle and meninges, β -galactosidase expression was always present with the longest constructs, but was also observed at low frequency in transgenic lines with shorter constructs. These results cannot distinguish between a model which localizes the active sequence in the far upstream region and models which consider the more frequent expression in the longest constructs as a conse-

quence either of promoter insulation by the larger DNA fragment or of a scattered distribution of weak activating elements. To throw light on these issues, 23 transgenic lines were produced with the constructs delineated in Fig. 1 B, which were obtained by fusing the proximal 1.4-kb of the $\alpha 1(VI)$ promoter with either fragment -4.0 to -5.4 [construct 5.4 Δ (4.0-1.4)lacZ] or fragment -5.4 to -6.2 [construct 6.2 Δ (5.4-1.4)lacZ] or fragment -6.2 to -7.5 [construct 7.5 Δ (6.2-1.4)lacZ]. The distribution of X-gal staining for these lines in the nine relevant tissues is reported in Table II and can be summarized as follows. (a) As expected by the presence of the proximal 1.4-kb fragment, all the lines expressed the transgene at the site of insertion of superficial aponeurosis and in tendons. (b) Activation in nerves was conferred only by fragment -4.0 to -5.4 . (c) Inducing activity in the vibrissae and in the subepidermal mesen-

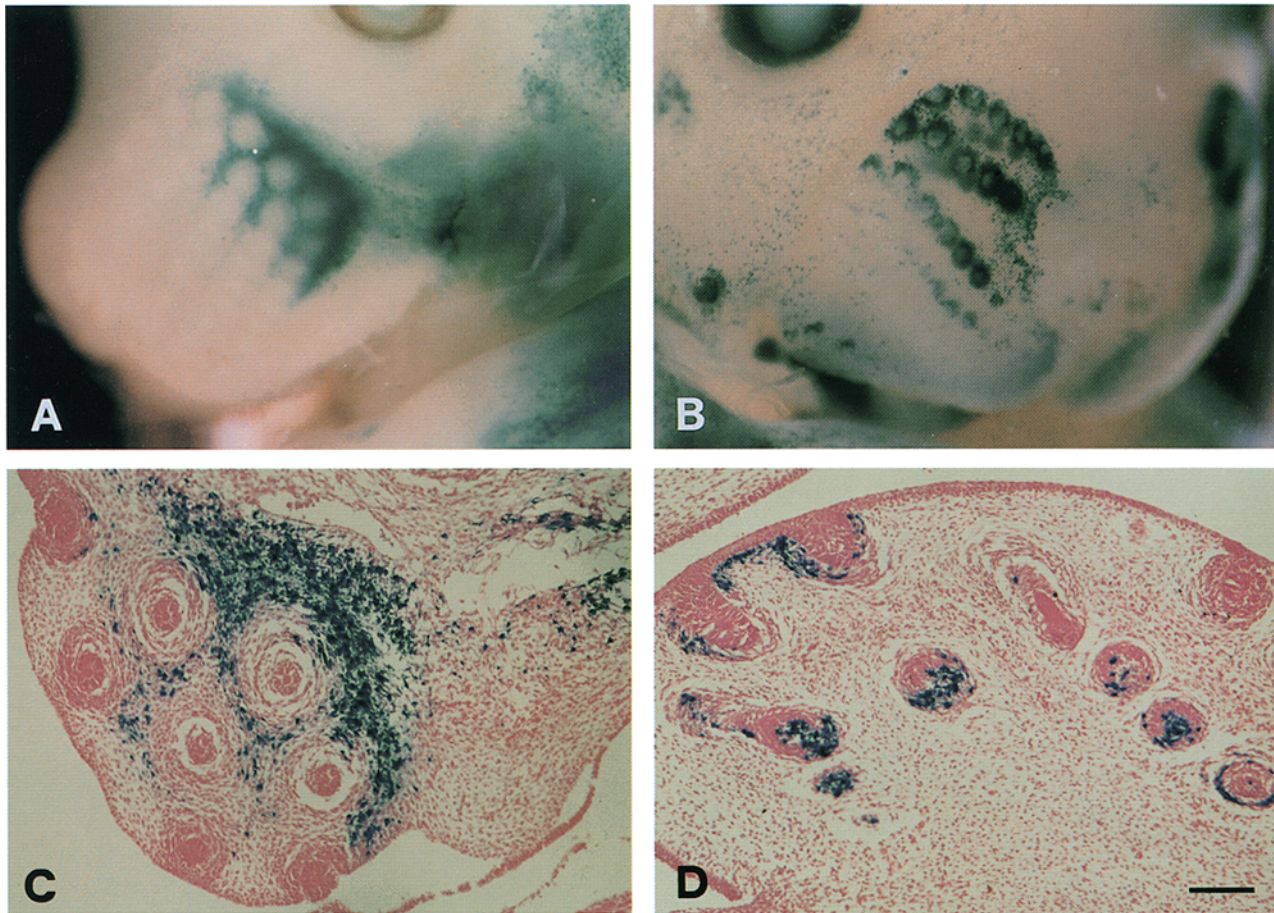

Figure 10. Constructs $7.5\Delta(6.2-1.4)\text{lacZ}$ and $5.4\Delta(4.0-1.4)\text{lacZ}$ are expressed in different domains of the region of vibrissae. (*A* and *B*) Whole mount X-gal staining of embryos of lines $7.5\Delta(6.2-1.4)\text{lacZ8}$ and $5.4\Delta(4.0-1.4)\text{lacZ7}$. (*C* and *D*) Histological picture of the area shown in *A* and *B*, respectively. Bar, 100 μm .

chyme was present in the -4.0 to -5.4 and -6.2 to -7.5 sequences, but was absent in the -5.4 to -6.2 fragment.

Interestingly, staining differed between the two constructs $5.4\Delta(4.0-1.4)\text{lacZ}$ and $7.5\Delta(6.2-1.4)\text{lacZ}$. In $7.5\Delta(6.2-1.4)\text{lacZ}$ lines strongly positive vibrissae were located in the ventral-posterior quadrant (Fig. 10 *A*). This same area was poorly stained in the $5.4\Delta(4.0-1.4)\text{lacZ}$ lines, in which labeling was detected in the remaining quadrants (Fig. 10 *B*). Significant differences were also observed at the histological level: in $7.5\Delta(6.2-1.4)\text{lacZ}$ lines X-gal labeled nuclei were more abundant in the outer layers of the dermal sheath and in the mesenchyme between follicles (Fig. 10 *C*), whereas in $5.4\Delta(4.0-1.4)\text{lacZ}$ lines β -galactosidase positive cells were almost exclusively found in the inner layers of the dermal sheath and in the dermal papilla (Fig. 10 *D*). (*d*) Joints and intervertebral disks were positive in all the transgenic lines with construct $5.4\Delta(4.0-1.4)\text{lacZ}$, and in 9 out of 11 lines with construct $7.5\Delta(6.2-1.4)\text{lacZ}$, whereas, out of 5 lines obtained with construct $6.2\Delta(5.4-1.4)\text{lacZ}$, only one, with multiple transgene copies, showed labeling. (*e*) High frequency of activation (100% of lines) in muscle and meninges was found when the region -6.2 to -7.5 was present [$7.5\Delta(6.2-1.4)\text{lacZ}$ lines]. Among the remaining lines, labeling could be detected only in one $5.4\Delta(4.0-1.4)\text{lacZ}$ line for each tissue.

Discussion

The main conclusion suggested by the experiments presented in this study is that the transcriptional activation of the $\alpha 1(\text{VI})$ collagen gene in different tissues during embryonic development is regulated by multiple *cis*-acting elements scattered over several kilobases of genomic sequence. The region analyzed extends from the transcription start site to 7.5 kb upstream and contains sequence information for expression in several collagen VI producing tissues, including sites of insertion of superficial and muscular aponeurosis, tendons, joints, intervertebral disks, nerves, subepidermal mesenchyme, vibrissae, skeletal muscle, and meninges. This is only a subset of the organs which express type VI collagen in their connective tissue (Marvulli et al., 1996). Thus, transgenes were not active in the mesenchyme of the digestive tract and the adjacent glands, in the lung, in the kidney, in the cornea, in the periosteum and perichondrium, in the gonads, and in the adrenal glands. Our suggestion is that, in all these organs, transcription is dependent on regulatory sequences not included in the DNA genomic fragment studied here. Preliminary experiments in which we have extended our analysis to the region from -7.5 to -14.0 kb confirm this conclusion: the addition of this region apparently activates β -galactosi-

Table II. Analysis of Tissue Specific Activating Sequences in the Promoter Region -4.0 to -7.5*

Line	Copy number	Age of embryos (days)	Tissues								
			Insertion of superficial aponeuroses	Tendons and ligaments	Joints	Inter-vertebral disks	Nerves	Subepidermal mesenchyme	Vibrissae (mesenchyme)	Skeletal muscle	Meninges
5.4Δ(4.0-1.4)lacZ1	1	14.5	++++	+	+++	++	++++	±	++	-	+
5.4Δ(4.0-1.4)lacZ2	1	14.5	++	+	±	±	+	±	+	-	-
5.4Δ(4.0-1.4)lacZ3	1	15.5	+++	+++	+	+	++	-	+	±	-
5.4Δ(4.0-1.4)lacZ4	1	15.5	++	++	++	++	++++	±	+++	-	-
5.4Δ(4.0-1.4)lacZ5	1	15.5	++	+	+	+	+	±	+	-	-
5.4Δ(4.0-1.4)lacZ6	1	15.5	++	+	+	+	+	+	+	-	-
5.4Δ(4.0-1.4)lacZ7	1	15.5	++	+	+++	+++	+++	+	+++	-	-
6.2Δ(5.4-1.4)lacZ1	4	15.5	+	+	+	+++	-	-	-	-	-
6.2Δ(5.4-1.4)lacZ2	1	15.5	+	±	-	-	-	-	-	-	-
6.2Δ(5.4-1.4)lacZ3	1	15.5	++	+	-	-	-	-	-	-	-
6.2Δ(5.4-1.4)lacZ4	1	15.5	+	±	-	-	-	-	-	-	-
6.2Δ(5.4-1.4)lacZ5	4	15.5	+++	+	-	-	-	-	-	-	-
7.5Δ(6.2-1.4)lacZ1	1	14.5	++	+	-	-	-	+	+	+++	+
7.5Δ(6.2-1.4)lacZ2	1	14.5	+	+	-	-	-	-	+	++	+
7.5Δ(6.2-1.4)lacZ3	1	15.5	++	++	±	++	-	+	+++	+++	+
7.5Δ(6.2-1.4)lacZ4	1	15.5	+++	++	+	++	-	+	++	+++	+
7.5Δ(6.2-1.4)lacZ5	1	15.5	++	+	±	+	-	+	+	+++	+
7.5Δ(6.2-1.4)lacZ6	1	15.5	++++	++	++	+++	-	++	+++	+++	+++
7.5Δ(6.2-1.4)lacZ7	1	15.5	+++	+++	+	+	-	+	+++	+++	+++
7.5Δ(6.2-1.4)lacZ8	1	15.5	+++	++	++	+++	-	+	+++	+++	++
7.5Δ(6.2-1.4)lacZ9	1	15.5	+++	+	±	+++	-	+	+++	+++	++
7.5Δ(6.2-1.4)lacZ10	1	15.5	+++	++	+	+	-	±	++	++	±
7.5Δ(6.2-1.4)lacZ11	10	15.5	++	++	+	+++	-	+	++	+++	++
Control [§]		9.5 to 16.5	++++	+++	++++	++++	+++	++++	++++	++++	+++

The region -4.0 to -7.5 was studied producing transgenic animals with the three constructs defined in Fig. 1 B. The founder animals were sacrificed at the embryonic age indicated and analyzed for β-galactosidase expression as detailed in footnote of Table I.

[§]Determined by immunohistochemistry and in situ hybridization experiments (Marvulli et al., 1996). Arbitrary scale from no (-) to very intense (++++) staining.

dase expression in several other tissues, including lung, digestive tract, and cornea (Braghetta, P., manuscript in preparation). On the other hand, transgenes were expressed in the central nervous system and in the retina, tissues where collagen VI was not detected (Marvulli et al., 1996). Ectopic induction of transgenes in the central nervous system has been observed with promoters for type I collagen chains (Niederreither et al., 1992; Rossert et al., 1995; Sokolov et al., 1995). In experiments comparable to those described here, however, a much lower frequency in different lines has been reported (~30%: Niederreither et al., 1992) compared to ours (~95%). The reason for this high frequency of activation is not known; one possibility is that negatively acting elements normally suppress transcription of α1(VI) in the central nervous system and retina and that these sequences are not contained in the promoter fragments we have studied.

As for the collagen VI-producing tissues where the transgenes were expressed with high frequency, analysis of Tables I and II suggests the following conclusions on the transcriptional regulation of α1(VI) (summarized in Fig. 11).

(A) In all the transgenic lines examined expression was active at low levels in tendons and, at high levels, in discrete areas of the limb buds, in the armpit and the groin and in front of the ear. The latter distribution of β-galactosidase staining was rather odd, being detected in apparently unrelated locations. Careful histological analysis,

however, revealed staining of cells at the sites of insertion of the superficial and muscular aponeurosis as a common motif. These sites were the skin and the ear cartilage. The superficial aponeurosis is a fibrous connective tissue which divides the subcutaneous tissue into a superficial and a deep layer (see Fig. 3 F). In most mammals it contains skeletal muscle fibers, the cutaneous muscles (see Fig. 8 B), also known as *panniculus carnosus*, which have the function to move the skin. In human, this tissue has been very well studied and has been designated SMAS (Mitz and Peyronie, 1976), a term which has been adopted here also for the mouse to stress its fascial (aponeurotic) nature. Human SMAS does not contain muscle in most body locations except in the face where it envelops the facial muscles, which are important in determining the characteristic expression of each person. It is worth noting that the human SMAS of the face attaches posteriorly to the tragus and penetrates anteriorly into the fibers of the orbicular muscle of the eye. The corresponding locations of mouse embryos contained cells expressing the transgenes at high levels. Our immunohistochemical results (Marvulli et al., 1996) indicate that collagen type VI is particularly abundant at the sites of insertion of SMAS. The surrounding dermis, however, contains collagen VI too. This situation may explain why this particular area of collagen type VI deposition has not been noted previously.

Positively acting elements for insertion of SMAS and

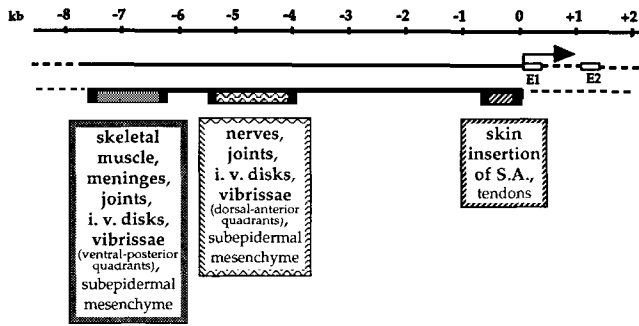

Figure 11. Summary of the distribution of regulatory regions controlling tissue-specific expression of the $\alpha 1(\text{VI})$ collagen gene. Only regions producing high frequency X-gal staining in the different transgenic lines are indicated. For a particular promoter region, tissues in which β -galactosidase expression was strong (see scale in Table I) are in bold letters. Arrow indicates the transcription initiation site of the gene; E1, E2, first, and second exon. The sequence examined in this study is represented by the continuous thick line. S.A., superficial aponeurosis; *i.v.* disks, intervertebral disks.

tendons are contained within the first 600 bp upstream of the transcription start site. In fact, all the lines generated expressed the reporter gene in these tissues and the 600-bp are the only promoter sequence common to the different transgenes. A confirmation of this conclusion comes from recent experiments on the production of transgenic lines with lacZ constructs similar to those of Fig. 1 B in which the 1.4-kb fragment of the $\alpha 1(\text{VI})$ promoter has been substituted by the human β -globin basal promoter (55 bp). Preliminary data have shown that a β -globin construct containing the fragment -4.0 to -5.4 of the $\alpha 1(\text{VI})$ promoter had a tissue pattern of expression equivalent to the corresponding $5.4\Delta(4.0-1.4)\text{lacZ}$ constructs with the exception of insertions of SMAS and tendons, where expression was missing (Braghetta, P., unpublished results).

(B) Transcriptional induction in joints, intervertebral disks, subepidermal mesenchyme, and nerves was absolutely dependent on sequences located upstream of -4.0 . The data reported in Table II indicate that the region from -4.0 to -7.5 contains more than one *cis*-activating sequence for joints, intervertebral disks, and subepidermal mesenchyme. In particular, one element(s) is located between -4.0 and -5.4 and a second element(s) between -6.2 and -7.5 . In addition, a third element(s) with low activity for joints and intervertebral disks may be contained in the fragment -5.4 to -6.2 , since one of the two $6.2\Delta(5.4-1.4)\text{lacZ}$ lines with multiple transgene copies exhibited β -galactosidase expression.

On the other hand, sequences responsible for expression in nerves were restricted to the region -4.0 to -5.4 . Potential cell types expressing the transgenes include Schwann cells, fibroblasts, and perineurial cells, all of which have been shown to produce type VI collagen in human (Peltonen et al., 1990). Preliminary experiments from our laboratory have revealed that the X-gal positive cells in nerves stain for markers of peripheral glia, suggesting that they likely belong to the Schwann cell lineage (Vitale, P., manuscript in preparation). At the moment, however, we cannot exclude the possibility that fibroblasts and peri-

neurial cells also express the transgene. The existence of *cis*-acting elements regulating specific transcription of the $\alpha 1(\text{VI})$ collagen chain in nerves suggests a special role of type VI collagen in this tissue. Given the early stage of activation of the transgene (11.5-d embryo) and the rapid increase of its expression, one attractive hypothesis is that collagen VI favors the initial morphogenesis of the nerves.

(C) Expression of the transgenes in the mesenchyme of vibrissae was strongly dependent on the regions -4.0 to -5.4 and -6.2 to -7.5 . However, expression at low frequency was also observed with constructs 2.8lacZ (1 in 4 lines) and 4.0lacZ (1 in 7 lines). The interpretation of this result is that either transcription was induced by the particular site of insertion of the transgene in these lines or the region between -1.4 and -4.0 comprises positive regulatory sequences with low activity. The latter interpretation seems more likely, since the two expressing lines have multiple copies of the transgene, a condition which favors expression of weak promoters. Transcription in different domains of the area of vibrissae and of different layers of mesenchyme around the follicles are dependent mainly on two distinct promoter regions. This finding suggests an unexpected complexity in the cell population of this mesenchyme. Expression of different transgenes may therefore be considered a useful marker for the characterization of the two cell groups.

(D) Strong activating sequences for skeletal muscle and meninges were present in the fragment -6.2 to -7.5 . Considerations similar to those discussed under C for vibrissae lead to the conclusion that additional weak stimulatory sequences may be located also outside this fragment. The exact position of the elements is difficult to identify, due to the low frequency and low level of X-gal staining with constructs lacking the region -6.2 to -7.5 . As for muscle, the sporadic expression could be accounted for by the presence of a single weak element within -1 and 600 bp, but other possibilities cannot be ruled out. In the case of meninges, the minimum number of weak activating sequences deduced from the experiments is two, one between -1.4 and -2.8 , the other between -4.0 and -5.4 .

Collagen VI is produced in high quantities in skeletal muscle, where it is deposited very close to the surface of the myotubes (Marvulli et al., 1996). Collagen VI expression by myoblasts in vitro is low in the logarithmic phase of proliferation, increases quickly when subconfluent cells are induced to differentiate and declines before myotubes appear (Piccolo et al., 1995). Assuming that myoblasts in vivo have the same behavior, one would expect that high transgene expression will be detectable in myoblasts just before fusion, will become very low in fusing myoblasts, and will be absent in fully developed myotubes. Since, as reported for other systems, β -galactosidase is an appropriate reporter gene to follow the temporal expression of a promoter during development (Sham et al., 1993), staining should be found frequently in mononuclear cells, while β -galactosidase activity should be almost undetectable in myotubes. This expected expression pattern of the $\alpha 1(\text{VI})$ promoter precludes a clear identification of the cells producing the transgene based on morphological data only. To settle this issue will require labeling with probes for specific markers of myoblasts. Characteristically, the expression levels of the transgenes varied in different mus-

cles. This variation was not random, since the pattern of relative intensity was similar in the various positive mouse lines. Since no such differences could be detected in the expression of the endogenous $\alpha 1(\text{VI})$ gene by in situ hybridization and immunohistochemistry (Marvulli et al., 1996), it should be concluded that the 7.5-kb of regulatory sequence analyzed here contains only partial information for transcriptional activation in skeletal muscle.

Since type VI collagen is widely distributed and found in most connective tissues, one would expect a simpler regulation of its genes. However, a thorough analysis of type VI collagen products during development has unveiled an elaborate pattern of expression (Marvulli et al., 1996). For example, the mRNA steady-state levels are first detectable in the various tissues at different stages and show different dynamics in embryonic and postnatal life; moreover, at variance with type I collagen, the abundance of both mRNA and protein in the connective tissues underneath epithelia is not homogeneous, but decreases with the distance from the basement membrane. Complex patterns of expression have been described for other proteins of the extracellular matrix, but information on their transcriptional regulation is usually limited. An exception is type I collagen, for which numerous studies on promoter activity in transgenic animals are available (Niederreither et al., 1992; Pavlin et al., 1992; Liska et al., 1994; Rossert et al., 1995; Sokolov et al., 1995). Overall, these studies favor the idea that separate cell-specific *cis*-acting elements activate collagen I genes in different type I collagen-producing cells. This modular arrangement of regulatory elements would endow type I collagen, and, as suggested in this study, type VI collagen chains, with a great potential of adjusting expression levels at adequate locations and times during complex developmental processes such as those of tissue and organ morphogenesis.

We thank Dr. M. Vitadello (Dipartimento di Scienze Biomediche e Sperimentali of the University of Padova Italy) for the gift of the monoclonal antibody against mouse neurofilaments and Dr. A. Colombatti (Centro di Riferimento Oncologico di Aviano, Italy) for providing the polyclonal antibody to mouse type VI collagen. We also thank Mr. Mauro Ghidotti for the maintenance of mouse colonies.

The financial support of Telethon (grant number E.22) and of the Progetto Finalizzato Invecchiamento of the Italian Consiglio Nazionale delle Ricerche is gratefully acknowledged.

Received for publication 10 July 1996 and in revised form 23 August 1996.

References

Adams, J.C., and F.M. Watt. 1993. Regulation of development and differentiation by the extracellular matrix. *Development*. 117:1183-1198.

Bidanset, D.J., C. Guidry, L.C. Rosenberg, H.U. Choi, R. Timpl, and M. Hook. 1992. Binding of the proteoglycan decorin to collagen type VI. *J. Biol. Chem.* 267:5250-5256.

Bonaldo, P., V. Russo, F. Bucciotti, R. Doliana, and A. Colombatti. 1990. Structural and functional features of the $\alpha 3$ chain indicate a bridging role for chicken collagen VI in connective tissues. *Biochemistry*. 29:1245-1254.

Bonaldo, P., S. Piccolo, D. Marvulli, D. Volpin, V. Marigo, and G.M. Bressan. 1993. Murine $\alpha 1(\text{VI})$ collagen chain. Complete amino acid sequence and identification of the gene promoter region. *Matrix*. 13:223-233.

Bonnerot, C., and J.-F. Nicolas. 1993. Application of LacZ gene fusions to postimplantation development. *Methods Enzymol.* 225:451-469.

Bruns, R., W. Press, E. Engvall, R. Timpl, and J. Gross. 1986. Type VI collagen in extracellular 100-nm periodic filaments and fibrils: identification by immunoelectron microscopy. *J. Cell Biol.* 103:394-404.

Butler, H., and B.H.J. Juurlink. 1987. An atlas for staging mammalian and chick embryos. CRC Press, Boca Raton, FL. pp 218.

Colombatti, A., P. Bonaldo, and R. Doliana. 1993. Type A modules: interacting domains found in several non-fibrillar collagens and in other extracellular matrix proteins. *Matrix*. 13:297-306.

Colombatti, A., M.T. Mucignat, and P. Bonaldo. 1995. Secretion and matrix assembly of recombinant type VI collagen. *J. Biol. Chem.* 270:13105-13111.

Dani, C., A. Doglio, E.Z. Amri, S. Bardou, P. Fort, B. Bertrand, P. Grimaldi, and G. Ailhaud. 1989. Cloning and regulation of a mRNA specifically expressed in the preadipose state. *J. Biol. Chem.* 254:10119-10125.

DeSimone, D.W. 1994. Adhesion and matrix in vertebrate development. *Curr. Opin. Cell Biol.* 6:747-751.

Hogan, B., F. Costantini, and E. Lacy. 1986. Manipulating the mouse embryo. Cold Spring Harbor Laboratory, New York. pp. 332.

Horton, W., T. Miyashita, K. Kohno, J.R. Hassel, and Y. Yamada. 1987. Identification of a phenotype specific enhancer in the first intron of the type II collagen gene. *Proc. Natl. Acad. Sci. USA.* 84:8864-8868.

Ibrahimi, A., B. Bertrand, S. Bardou, E.Z. Amri, P. Grimaldi, and G. Ailhaud. 1993. Cloning of $\alpha 2$ chain of type VI collagen and expression during mouse development. *Biochem. J.* 289:141-147.

Juliano, R.L., and S. Haskill. 1993. Signal transduction from the extracellular matrix. *J. Cell Biol.* 120:577-585.

Keene, D.R., E. Engvall, and R.W. Glanville. 1988. Ultrastructure of type VI collagen in human skin and cartilage suggests an anchoring function for this filamentous network. *J. Cell Biol.* 107:1995-2006.

Lin, C.Q., and M.J. Bissel. 1993. Multi-faceted regulation of cell differentiation by extracellular matrix. *FASEB (Fed. Am. Soc. Exp. Biol.) J.* 7:737-743.

Liska, D.A.J., M.J. Reed, and P. Bornstein. 1994. Cell-specific expression of $\alpha 1(\text{I})$ collagen-hGH minigenes in transgenic mice. *J. Cell Biol.* 125:695-704.

Lovell-Badge, R.H., A.E. Bygrave, A. Bradley, E.J. Robertson, R. Tilley, and K.S.E. Cheah. 1987. Tissue specific expression of the human type II collagen gene in mice. *Proc. Natl. Acad. Sci. USA.* 84:2803-2807.

Marvulli, D., D. Volpin, and G.M. Bressan. 1996. Spatial and temporal changes of type VI collagen expression during mouse development. *Dev. Dynamics*. 206:447-454.

Mitz, V., and M. Peyronie. 1976. The superficial musculo-aponeurotic system (SMAS) in the parotid and cheek area. *Plast. Reconstr. Surg.* 58:80-88.

Niederreither, K., R.N. D'Souza, and de B. Crombrughe. 1992. Minimal DNA sequences that control the cell lineage-specific expression of the pro $\alpha 2(\text{I})$ collagen promoter in transgenic mice. *J. Cell Biol.* 119:1361-1370.

Pavlin, D., A.C. Lichtler, A. Bedalov, B.E. Kream, J.R. Harrison, H.F. Thomas, G.A. Gronowicz, S.H. Clark, C.O. Woody, and D.W. Rowe. 1992. Differential utilization of regulatory domains within the $\alpha 1(\text{I})$ collagen promoter in osseous and fibroblastic cells. *J. Cell Biol.* 116:227-236.

Peltonen, J., S. Jaakkola, L.L. Hsiao, R. Timpl, M.-L. Chu, and J. Uitto. 1990. Type VI collagen. In situ hybridization and immunohistochemistry reveal abundant mRNA and protein levels in human neurofibroma, schwannoma and normal peripheral nerve tissues. *Lab. Invest.* 62:487-492.

Pfaff, M., M. Aumailley, U. Specks, J. Knolle, H.G. Zerwes, and R. Timpl. 1993. Integrin and Arg-Gly-Asp dependence of cell adhesion to the native and unfolded triple helix of collagen type VI. *Exp. Cell Res.* 206:167-176.

Piccolo, S., P. Bonaldo, P. Vitale, D. Volpin, and G.M. Bressan. 1995. Transcriptional induction of the $\alpha 1(\text{VI})$ collagen gene during differentiation of myoblasts is mediated by multiple Sp1-binding sites. *J. Biol. Chem.* 270:19583-19590.

Quarto, R., B. Dozin, P. Bonaldo, R. Cancedda, and A. Colombatti. 1993. Type VI collagen expression is upregulated in the early events of chondrocyte differentiation. *Development*. 117:245-251.

Rossert, J., H. Eberspaecher, and B. de Crombrughe. 1995. Separate *cis*-acting DNA elements of the mouse pro- $\alpha 1(\text{I})$ collagen promoter direct expression of reporter genes to different type I collagen-producing cells in transgenic mice. *J. Cell Biol.* 129:1421-1432.

Sham, M.H., C. Vesque, S. Nonchev, H. Marshall, M. Frain, R. Das Gupta, J. Whiting, D. Wilkinson, P. Charnay, and R. Krumlauf. 1993. The zinc finger gene Krox20 regulates HoxB2 (Hox2.8) during hindbrain segmentation. *Cell*. 72:183-196.

Sokolov, B.P., L. Ala-Kokko, R. Dhulipala, M. Arita, J.S. Khillan, and D.J. Prockop. 1995. Tissue-specific expression of the gene for type I procollagen (COL1A1) in transgenic mice. *J. Biol. Chem.* 270:9622-9629.

Specks, U., U. Mayer, R. Nischt, T. Spissinger, K. Mann, R. Timpl, J. Engel, and M.-L. Chu. 1992. Structure of recombinant N-terminal globule of type VI collagen $\alpha 3$ chain and its binding to heparin and hyaluronan. *EMBO (Eur. Mol. Biol. Organ.) J.* 11:4281-4290.

Vitadello, M., and S. Denis-Donini. 1990. Expression of neurofilament proteins in the granule cells of the cerebellum. *Brain Res.* 509:47-54.