

Chapter 6

The Actual Six Therapeutic Modalities

Parenteral administration of ozone may represent the key to solve some medical problems when orthodox medicine has failed to do so. To the old procedures: major and minor ozonated autohaemotherapy (AHT) and rectal insufflation, our work has permitted the addition of three new options and all of them will be critically examined in this chapter.

6.1 Major Ozone Autohaemotherapy (AHT)

This term indicates the classical and unsurpassed procedure by which a volume of blood is drawn from an arm vein, exposed to oxygen-ozone for at least 5 min with gentle mixing and reinfused either IV (major AHT) or IM (minor AHT) into the donor. “**Major**” and “**minor**” are only meant to indicate a different volume of blood: 50–225 ml for the former and 5–10 ml for the latter. The original idea to expose blood *ex vivo* to a gas mixture was proposed by Wehrli and Steinbart (1954), who published the method of irradiating blood with UV light in the presence of pure oxygen. This procedure, called HOT (Hamatogene oxidations therapie), is no longer used because it was uncertain with regard to the real concentration of ozone during UV irradiation of oxygen and was cumbersome and risky because the quartz ampulla had to be cleaned and sterilized after each treatment. Indeed a few cases of cross-infection with HCV, due to imperfect sterilization, were widely publicised to denigrate modern ozone therapy (Gabriel et al., 1996), that has nothing to do with HOT. This sort of serious cross-infections happened in the recent past owing to the negligence of physicians and nurses and have compromised the progress of ozonotherapy. In the 1960s, reliable medical generators became available and HANS WOLFF PROPOSED TO EXPOSE BLOOD DIRECTLY TO OXYGEN-OZONE, with the advantage of knowing its exact concentration. As early as 1974, he reported that he had used this method in many patients without any problem.

Unfortunately, **modifications were subsequently introduced that worsened the procedure**; for example, the use of only one tube to collect and reinfuse the blood (involving the risk of a clot formation and the disadvantage of an imperfect mixing of blood with gas) and even worse, since 1991 in Italy, the substitution

of neutral glass bottles, perfectly ozone-resistant, with plastic bags allowed only for blood storage because they are cheaper and easier to stow away. These bags are made of about 55% polyvinyl chloride (PVC) mixed with a number of additives, among which about 43% of phthalates (Valeri et al., 1973; Lewis et al., 1977; Lawrence, 1978; Thomas et al., 1978; Callahan et al., 1982; Labow et al., 1986; Whysner et al., 1996). These compounds make the PVC elastic but a minimal amount of phthalates is released into blood. This little contamination is permissible and bags are commonly used for storage of blood but **the problem arises after the addition of ozone into the bags because ozone causes a huge release of plastic microparticles (0.2–20 μm size) and phthalates into the blood with unknown but worrisome late consequences for the patient after reinfusion.** After my notification to Health Authorities in 1999, the Italian Ministry of Health established very clearly that plastic bags should never be used for ozonotherapy. In spite of this precise regulation, **some Italian ozonetherapists, shamefully unconcerned about the patient's safety, continue to use them!** Fortunately, this does not seem to happen in other European countries but, once again, this reprehensible behaviour discredits this approach. Phthalates may not be toxic but plastic microparticles, taken up by the reticulo-endothelial system in the spleen liver and bone marrow, may represent a potential cancerogenic stimulus. Luckily, by 2009, new solid and safe plastic containers have become available.

After several years of laboratory experimentation and clinical work, we have now optimised an autohemotherapeutic method (Fig. 6.1), that is fairly simple, ozone-resistant, absolutely atoxic and flexible in the sense that one can use a blood volume from 100 to 225 ml (depending on the patient), a suitable volume of sodium citrate 3.8% solution (10 ml citrate plus 90 ml of blood) or heparin (15–20 IU per ml of

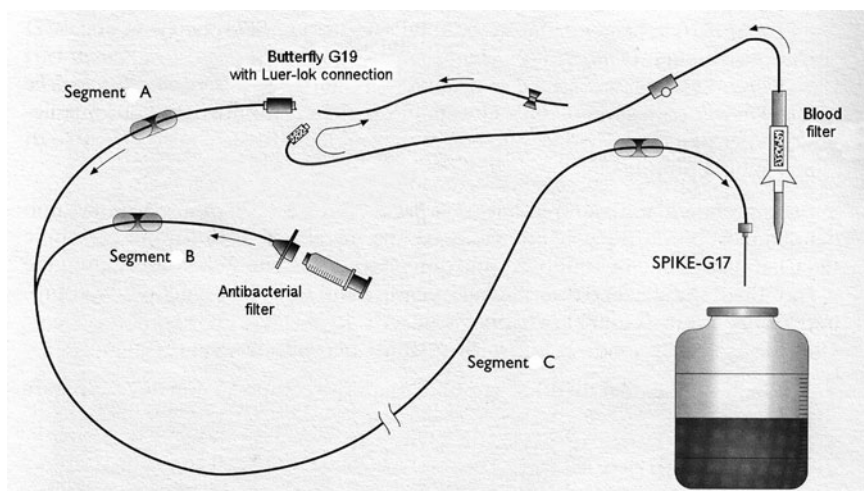

Fig. 6.1 A schematic drawing of the components necessary to perform the ozonated autohaemotherapy with a calibrated glass bottle

blood) and the necessary gas volume without increasing the atmospheric pressure in the glass bottle. The citrate (25 ml)-blood (225 ml) volume is equivalent to the gas volume (225 ml) with the simple blood-gas volume ratio of 1:1. Our device consists of (1) a neutral 500 ml glass bottle (sterile and under vacuum) where we inject, as a first thing, the chosen anticoagulant, (2) a new atoxic tubing with an Y form where one tubing (Segment A, when connected with the Butterfly G19) collects blood and the other (Segment B) is used for insufflating sterile-filtered O₂-O₃ via an antibacterial (0.2 μm), hydrophobic ozone-resistant filter. As one can see in the Fig. 6.1, both Segment A and B are connected to Segment C, which carries firstly blood and then gas inside the calibrated glass bottle, (3) a standard tubing (Blood filter) that is used, firstly for infusing saline and, secondly, for returning the ozonated blood to the donor. In this way, we perform only one venous puncture because, while we carry out the ozonation of blood, the patient receives a slow infusion of saline. It is important that the exposure of blood to the gas mixture lasts at least 5 min because mixing of blood MUST be gentle to avoid foaming. Because blood is very viscous, it takes 5 min to achieve a complete and homogenous equilibrium. It can be noted that the pO₂ slowly reaches suprphysiological values (up to 400 mmHg) and then it remains constant: on the other hand, ozone progressively dissolves in the water of the plasma but then reacts instantaneously with biomolecules so that the entire ozone dose is practically exhausted within 5 min. **The visible clamps in Segments A, B and C are open or shut throughout the procedure for allowing the passage of blood and gas without losing the vacuum.**

The ozonetherapist must follow this procedure for avoiding either negative effects on the patients, or being found guilty of medical malpractice. I can assure the ozonetherapist that, after a preliminary experience, this procedure apparently complicate is indeed easy, rapid and clean (Bocci, 2006a).

A brief digression is necessary in regards to blood anticoagulants. Is sodium citrate the best anticoagulant? It is, provided is not in excess (Chapter 7) to avoid a transitory hypocalcemia and it is safe in practically all patients, including those already under either anticoagulants (Warfarin, heparin, hirudin), or antiplatelet drugs (aspirin, dipyridamole, ticlopidine, clopidogrel), or thrombolytic agents (streptokinase, tissue plasminogen activator), or patients with hepatic diseases and a low prothrombin level. In these cases, use of heparin may aggravate the dyscoagulation and cause severe haemorrhages. I will remind that heparin can induce thrombocytopenia (Warkentin, 2003) and platelet micro-aggregation (Bocci et al., 1999a) using high ozone concentrations (near 80 mcg/ml per ml of blood). Nevertheless heparin is regularly used during EBOO and dialysis and, bearing in mind the above indicated restrictions, may be useful in vascular diseases and cancer because of the increased release of a number of growth factors from platelets (Valacchi and Bocci, 1999) and cytokines from leukocytes (Bocci et al., 1993a, b). Thus, only after a careful analysis of the patient, the ozonetherapist can select the most idoneous anticoagulant.

ONE BIG PROBLEM THAT WEAKENS THE VALIDITY OF OZONETHERAPY IS THAT OUR METHOD IS NOT USED BY ALL OZONETHERAPISTS. How can we compare anecdotal results (already

questionable), if ozonetherapists disagree about the blood and gas volumes, ozone concentrations and exposure times? What is most disheartening about this chaotic situation is that behind it there are commercial interests (plastic or glass, small or large bottles, lack of appropriate transfusion tubing with a filter, etc.), mental reservations, lack of basic knowledge and plain stupidity. Obviously this is an ideal ground for quacks but even an Italian physician, who thinks he is an excellent ozonetherapist, has boasted of performing the whole procedure in 6 min when the correct time is about 40 min! To my dismay, I recently heard that another ozonetherapist in Turin, as the first thing in the morning, fills up with the gas all the glass bottles to be used during the day! As ozone has a brief half-life, its concentration halves every 40 min!

Moreover there are two modifications regarding the technique of exposing blood to the gas that need to be briefly mentioned: the first (patented in USA) uses hollow capillary fibres and is expensive, unnecessarily complex and has resulted in a commercial failure. The second system delivers gas as mini bubbles and claims that full blood ozonation is achieved in a few seconds. We tested it and found considerable blood foaming because **gas should never be bubbled through the blood**. Furthermore we measured a marked hemolysis and a low oxygenation (pO_2 at about 90 mm Hg) meaning that the gas had not been entirely equilibrated with blood. By comparison our method requires at least 5 min of gentle mixing (to avoid foaming), but allows complete ozonation and oxygenation as it is well demonstrated by a very high pO_2 . Haemolysis remains negligible.

Another critical issue that remains to be scientifically settled is the volume of blood to be collected for each treatment. Needless to say the volume of blood should not be imposed by any commercial purpose or by a trivial timing aspect. The volume of blood must be flexible and must be in relation to the patient's body weight, sex, stage and type of disease. To avoid any risk of lipothymia, no more than 225 ml blood should be withdrawn and a 500 ml glass bottle appears suitable in all cases. In Germany, some practitioners believe that 50 ml, or at most 100 ml, is optimal. There is neither experimental nor clinical support for this contention and this belief disagrees with the classical biochemical and pharmacological concepts expressed in the previous chapter. *If we accept the evidence that ozone generates crucial messengers, such as ROS, LOPs, metabolic intermediates and autacoids that undergo dilution, degradation and excretion but that, after their interaction with cells, can express pharmacological effects, we have to consider that a minimal stimulation or a small blood volume, may correspond only to either a placebo or to a homeopathic-like effect. Our contention is supported by the experimental finding that, in critical stages of hind limb ischemia, a dramatic improvement was observed immediately after the first treatment performed with large volumes (675–4,800 ml of blood).*

Our standard approach has been to perform 2 or 3 treatments weekly, usually using 225 ml of blood each time, for 13–15 sessions. This schedule is practical, appears effective in most patients but can be modified to satisfy individual requirements.

Has the classical AHT any other disadvantage? The limitation of blood volume can be easily overcome by performing successively up to three AHTs, within 2 h,

on the whole ozonating about 675 ml of blood without any side effects, as I have tested on myself and in several patients.

Unless the ozonetherapist owns a reliable portable generator, domiciliary treatment, that could be very useful in some emergencies, cannot be performed. Nevertheless, superficiality and malpractice are endless and one German ozonetherapist boasted of performing several AHTs every morning by first loading with ozone small glass bottles at his clinics and then going around town to the patients' homes to give treatments, disregarding the fact that ozone concentration, depending upon the temperature, halves every 30–40 min. On hearing this story, one is filled with dismay because not even a shaman will do such a thing.

A correct reinfusion of 225 ml blood plus 25 ml citrate solution takes about 20 min without any problem because **it is autologous blood**. Nonetheless we must carefully check the haemostasis and avoid haematic extravasation which may compromise the continuation of the therapy. Great care must be exercised to maintain the venous access in the best condition, particularly in women. Risk of infections (HIV, HCV, etc.) among patients and ozonetherapist must be prevented and we fully agree with Webster et al. (2000) that some mistakes, e.g. repeatedly using a contaminated needle, or a syringe, or a solution, are inadmissible.

If, SEVERAL AHTs ARE PERFORMED SIMULTANEOUSLY, ALL GLASS BOTTLES MUST HAVE THE PATIENT'S NAME to prevent mistakes during reinfusion, with possible dramatic consequences. In any case, we write the name even for a single AHT.

One important question to answer is if we can perform an ozonated well-characterised, **allogeneic** blood transfusion in cachectic, anemic or in AIDS patients. While, after having performed 9,000 autologous transfusions, there has not been a single case of transfusion-related acute lung injury or other noxious effects, **in Italy we are not allowed to do a blood allogeneic transfusion. Only a physician who is also a specialist in blood transfusion can do that.** If it is absolutely necessary, blood must be subjected to a leukocytes and platelets depletion step (Williamson, 2000) and then, after ozonation, must be infused very slowly, as any allogeneic transfusion. Provided it is done with great caution and very SLOW infusion, the ozonated allogeneic blood transfusion may help critical patients.

Finally **AHT has a few potential drawbacks**: the first is that AHT is not a simple little pill to swallow at home because the patient must go to a public or private clinic to receive the treatment. As a consequence, AHT can be advised only when absolutely indispensable and not replaceable by an equally effective conventional medication. However I have learnt that patients, once realize the clear-cut efficacy of AHT, do not hesitate to continue the maintenance treatments for years. Obviously the ozonetherapist must have a perfect competence for performing AHT in the smoothest possible way. Indeed some ozonetherapists do not feel skilled enough and prefer to perform other more rewarding tasks. The second problem is that medical personnel working in infectious disease wards are somewhat reluctant to deal continuously with infected blood and needles and the third is the occasional lack of venous access. These are not trivial problems: one may be solved by the use of an idoneous blood substitute, that can be slowly injected into small veins. In the case

of a difficult venous access, we can propose three options: (a) cannulation of a central vein, keeping in mind some risks (Renaud and Brun-Buisson, 2001; Castagnola et al., 2003), (b) quasi-total body exposure to oxygen-ozone in a appropriate cabin, (c) rectal insufflation of gas.

6.2 Minor Ozone Autohaemotherapy

In the 1950, when I was a medical student, we used to do IM injections of either autologous freshly drawn blood or sterile milk as unspecific immunomodulators. This practice is then very old and continues to be used also without ozone (Olwin et al., 1997). Wolff may have had the good idea of ozonating blood in the hope of activating its components.

The technical procedure is empirical and simple: firstly, I collect the blood (5 ml) in a 10 ml syringe, and secondly, via a two-way stopcock, I add an equal volume of filtered oxygen-ozone at ozone concentrations between 40 and 100 mcg/ml depending upon the scope of the treatment and the disease. One can, more simply, first collect the 5 ml of gas and then withdraw, less precisely, about 5 ml of blood. In both cases, the blood, vigorously mixed with the gas, develops abundant foaming and certainly in this case the whole ozone dose reacts in less than 1 min. After disinfecting the buttock skin and checking not to have penetrated a vessel, I inject the ozonated blood in the buttock muscle, blood and foam in one site, without causing pain. We can do multiple injections or repeat them 2–3 times weekly. We do not know whether the IM or SC administration in multiple sites is more effective. Under an ozonetherapist guidance, a nurse's help and the availability of an ozone generator, the patient can easily do her/his own therapy at home.

What is the rationale of this sort of unspecific proteintherapy coupled to ozone remains conjectural and a scientific investigation will be useful. At the moment I can only speculate that blood, without anticoagulant, will infiltrate into the muscle tissue or the subcutis and will undergo coagulation due to platelet and prothrombin activation. If we delay the injection, this can happen already in the syringe!

Several processes, such as fibrinolysis, serum reabsorption via lymphatic vessels and a mild sterile inflammatory reaction, are likely to take place as occasionally suggested by a slight swelling at the injection site reported by some patients during the next few days. Chemotactic compounds released at the site may stimulate the local infiltration of monocytes and neutrophils, which take up haemolysed erythrocytes and denatured proteins. Activated monocytes and lymphocytes may release interferons and interleukins either in loco or along the lymphatic system, upregulating the physiological cytokine response (Bocci, 1981c, 1988a). Thus it would be quite interesting to evaluate some immunological parameters and ascertain if there is a simultaneous induction of heme-oxygenase-1 (HO-1) and some other heat shock proteins (Tamura et al., 1997) that may enhance immune reactivity and explain the beneficial effects.

The minor AHT is easy to perform, atoxic, inexpensive and, if we could perform a controlled clinical trial, it could become a very useful tool in some affection. So far we have only anecdotal data in patients with herpes I and II, acute herpes zoster and post-herpetic neuralgia (Konrad, 2001). A similar approach has been publicized by Cooke et al. (1997), who claim great advantages in Raynaud's disease, by using a particular formulation in which blood is treated with ozone, heat and UV light. When discussing chronic heart failure, I will clarify that this procedure recently denominated *Celacade* has been a real failure in eliciting a beneficial effect (Torre-Amione et al., 2008). A similar methodology was proposed by Garber et al. (1991) and uselessly tested in AIDS patients. I feel that we should test seriously only ozone before complicating the problem with the seemingly superfluous addition of heat and UV irradiation. During the last few years, in almost all patients, I started to perform both major and minor AHT at the same time and I have noted a marked improvement of the therapeutic response suggesting a synergistic effect and **ABSOLUTELY NO ADVERSE EFFECTS**.

The problem of new vaccines is becoming urgent and I had already proposed the use of ozone as an agent able to eliminate the infectivity, while enhancing the immunogenicity of a pathogen (Bocci et al., 2009b).

Once we have demonstrated the ozone capacity to inactivate a virus, the idea of a possible autovaccination, by heavily ozonating small volumes (3–5 ml) of infected plasma with ozone at high concentration (400 or more mcg/ml per ml of plasma) does not seem farfetched. The oxidation of viral components may represent an effective immune stimulant in several chronic viral diseases, from herpes to cytomegalovirus, HIV, HCV, possibly HIV, just to cite a few because there are many pathogenic agents. Infected blood may even be better because it may well contain intracellular pathogens as well and displays an adjuvant activity. The autovaccine can be either injected via IM or SC or intra-epidermal injections for facilitating the uptake by Langerhans cells. For some pathogens we could also use the oral route. **I HAVE APPLIED THE SAME REASONING FOR CANCER PATIENTS** and I have used the minor AHT as a sort of autovaccine. Unfortunately terminal patients, after intensive chemotherapy, were immune suppressed and unreactive.

The minor AHT has no record of side effects. This corresponds very well with my experience. However I cannot omit to report the excellent paper by Webster et al. (2000), who described the careless and unforgivable performance of some incompetent operators in a naturopathic clinic in London (!!). They were treating patients by using the old minor AHT, **WITHOUT OZONE**, and they were diluting blood (**WHY? WAS IT NECESSARY?**) **WITH SALINE COLLECTED ALWAYS FROM A CONTAMINATED BOTTLE**. In this way they infected more than 70 patients with HCV!!!

It is most unfortunate that incompetent mass media, when they heard about this misdeed, which occurred with autohaemotherapy, attributed the fault to ozonotherapy when clearly **ozone was NOT GUILTY and actually, if present, might have blocked the infection!**

6.3 The Biooxidative Therapy with Hydrogen Peroxide Dissolved in the Isotonic Glucose or Saline Solution. The Problem of the IV Infusion of Ozonated Saline and of Ozone Dissolved in Water. The Continuous Search of an Efficacious Blood's Substitute. *Does the Ascorbate Solution Solve This Problem?*

Particularly in infectious diseases wards, I often found that both physicians and nurses are reluctant to perform AHT because they are afraid of accidentally pricking themselves with an infected needle. That is the main reason why I have often been asked to find an efficacious solution to be directly infused in the place of blood.

About 15 years ago I spent considerable time searching a suitable solution and eventually I found that the simple saline (NaCl: 0.9%) could react with ozone better than any other electrolyte solution. At first it appeared to be a possible solution because it was easily administered with a very thin needle (G27) in patients with a poor venous access. However, after ozonating saline with an ozone concentration of 80 mcg/ml, I tested it personally and, in spite of a considerable blood dilution during the slow infusion, the next day I felt a painful irritation along the venous path up to the axilla. I realized that the ozonated saline was somewhat caustic and could cause a chemical phlebitis. Then I went to my lab and I measured the instantaneous formation of hydrogen peroxide, that was a good thing, but also of hypochlorous acid (HOCl), that was a bad thing. Traces of Fe^{++} unavoidably present in the saline solution could also catalyze the formation of hydroxyl radicals (OH^-) and of other radicals with very short half-life. In 1995, I was surprised to observe that ozonated saline was widely used in Russia and to discover that it was also used in Italy by a few charlatans. However, at least in Russia, it did not seem to procure significant damage because the ozonation was performed by using an extremely low level of ozone (about 2–3 mcg/ml), so that practically it worked as a placebo.

Now I must strongly recommend to avoid the use of ozonated saline owing to inherent toxicity or/and doubtful pharmacologic activity. I will discuss this problem in the next few pages.

Let us now examine other possibilities: Pryor et al. (1995) and our study (Bocci et al., 1998a) have made sure that hydrogen peroxide is one of the most important ROS (generated by ozone), that can physiologically activates several targets although, in excessive amounts, can be a damaging oxidant. Interestingly, Dr. I.N. Love (1888!) working in St. Louis published a note entitled “Hydrogen peroxide as a remedial agent” after he had obtained beneficial effects after topically using a diluted solution of hydrogen peroxide. We must admire Love’s insight into a problem that, not long ago (Babior, 1978; Badwey and Karnovsky, 1980) has clarified that our white cells can win their daily battle against pathogens only if they can deliver and kill bacteria with ROS (anion superoxide, hydrogen peroxide, singlet oxygen, etc.).

Today, for the disinfection of wounds, everyone uses the 3.6% solution of hydrogen peroxide which, among disinfectants, is one of the most efficacious. Subsequently, Dr. C.H. Farr (1993) promoted the use of IV administration of a

dilute solution of hydrogen peroxide in several illnesses, very similar to those treated with ozonotherapy. Almost needless to say, hydrogen peroxide must be considerably diluted before its contact with blood in order to avoid dangerous oxygen embolism and endothelial damage. Dr. Farr is acknowledged as one of the founders of biooxidative therapy, included among the complementary medical approaches by the National Institutes of Health.

The precise formulation of the solution (that I briefly call the GLUCOSE or SALINE (NaCl 0.9%)-PEROXIDE solution) for IV administration, first elaborated by Dr. Farr, consists of a few steps that I have simplified and improved:

- (1) A 15% solution is prepared by diluting 30% reagent grade H_2O_2 with an equal volume of apyrogenic, sterile bidistilled water. I never store this solution and I use it immediately.
- (2) In order to prepare the final solution when needed, it is necessary to dilute 0.5 ml of the sterile 15% H_2O_2 solution with 250 ml of either 5% sterile glucose solution or, in case of a diabetic patient, in sterile physiological saline. I would like to recommend: (a) to withdraw the 0.5 ml without the use of a metal needle because iron (from the needle) will contaminate the solution and enhance formation of hydroxyl radicals; (b) there is no need to filter the 15% solution, that is directly injected (0.5 ml), via a sterile plastic spiked cannula, into the isotonic 5% glucose solution flask or in saline solution; (c) to administer intravenously as a common drip infusion. In the rare case of an intrahepatic arterial catheter, it must be slowly administered with a syringe to counteract the arterial pressure; (d) to use it during the day. I would like to point out that **the hydrogen peroxide titre in the glucose solution remains quite stable, even at 20°C, for at least 3 days** (Bocci et al., 2005). The stability of hydrogen peroxide dissolved in saline has not yet been tested and therefore it should be used immediately after its preparation. The final hydrogen peroxide concentration is equivalent to 0.03%, is isotonic and suitable for direct slow (20–30 min) IV infusion. It may be worthwhile reminding physicians, who like to make strange solutions, to **avoid mixing the 0.03% H_2O_2 solution with antioxidants (vitamin C, GSH), amino acids, minerals, etc.**, to avoid negative interference and the instantaneous reduction of hydrogen peroxide to water. Depending on the stage and type of disease, treatments can be carried out daily, every other day or twice weekly.

I have been told that, for serious illnesses, Dr. Farr has slowly infused a five-fold greater concentration (0.15%, i.e. 2.5 ml of the 15% H_2O_2 solution diluted into 250 ml of 5% glucose solution), with “excellent results”. In order to avoid toxicity and to allow adaptation to chronic oxidative stress, I would suggest a gradual increase of the total volume (from 125 to 250 ml) and an increase of the concentration to no more than 0.06%. I have tried on myself one 250 ml preparation even at 0.09% infused in 30–40 min, without any adverse effects, in contrast to ozonated saline. To be very cautious, one can prolong the infusion for 1 h. Dr. Farr has performed IV infusions of a 0.03% solution in many patients

affected by several diseases. The IV administration of glucose-peroxide solution in arterial and heart ischaemia and in cancer has been reported by Urschel Jr. (1967). Interesting studies on the antitumoural effects of H_2O_2 have been reported by Sasaki et al. (1967), Nathan and Cohn (1981) and Symons et al. (2001). Los et al. (1995) and several other Authors have shown that hydrogen peroxide is a potent activator of lymphocyte functions in vitro (Los et al., 1995). Activated leucocytes by releasing H_2O_2 and IL-2 can kill neoplastic cells (See the cancer therapy chapter).

While this approach has been widely used in the USA, Canada and Mexico, it has not been used in Russia and Germany. To my knowledge, I am the only one to use it in Italy and, after thousands of infusions, I am sure of its atoxicity and of some pharmacological activity. **I have found that the “glucose-peroxide” solution, in the range 0.03–0.06% seems to be somewhat beneficial when infused in Age Related Macular Degeneration (ARMD) in women with small venous accesses incompatible with major AHT. I have also already carried out almost a thousand infusion of the solution (range: 0.03–0.06% or 8.8–17.6 mM) in non-diabetic cancer patients without any adverse effects.**

However it appears now absolutely necessary to compare laboratory and clinical results by testing the classical major AHT and the “glucose-saline-peroxide” solution in chronic limb ischaemia, age-related macular degeneration and chronic C hepatitis. However such a study appears difficult because to achieve clear statistical significance, it may be necessary to evaluate thousands of patients. Indeed the crucial question is: can the “glucose-saline peroxide” solution satisfactorily substitute AHT or other approaches using ozone? I must add that in seriously ill patients, I have compassionately used routinely the glucose-peroxide solution to supplement the AHT, particularly when patients can only come twice weekly for the treatment.

The proposal of this solution is not senseless, particularly since we know that this compound is one of the early ozone messengers. However, the question whether it is as effective as the major AHT remains open because late products, like LOPs, may be scarcely generated in vivo owing to the very rapid reduction of H_2O_2 to water. On the other hand, during blood ozonation, hydrogen peroxide is generated *ex vivo* in the bottle but it is rapidly reduced, whereas the direct infusion of the “glucose or saline peroxide” solution implies an immediate interaction with the blood pool. Moreover as it will be extensively discussed later in the section “cancer therapy, the third option”, recent studies by Levine et al. (2009) and Verrax and Calderon (2009), have pointed out a new information. The experimentation with ascorbate has clarified that after its IV infusion, **vitamin C readily generates hydrogen peroxide and ascorbate radical (ASC^{\bullet})** but, while their concentrations steadily increases in the interstitial fluids (up to 2–4 mM), it becomes negligible in the plasma owing to the potent antioxidant capacity of blood. In other words, it has been clarified that the life span of hydrogen peroxide in the plasma is extremely brief, actually so brief that the possibility of entering into blood cells for stimulating biochemical activities become doubtful. If this is true, one really wonder about any pharmacological effect of hydrogen peroxide during the infusion of either glucose or saline peroxide

infusion. Obviously, if this is so, one should then increase the hydrogen peroxide concentration to counteract its rapid reduction to water.

It must be added that the infusion, although it does not present the risk of the direct gas administration, must be performed slowly to avoid any risk of oxygen embolism. **Another disadvantage to bear in mind is that the “glucose-peroxide” solution cannot be used in diabetics.** In such a case we can dilute 0.5 ml of the 15% hydrogen peroxide solution in 250 ml of sterile physiological (0.9%) saline. The final concentration of hydrogen peroxide is 0.03% but this solution should be used at once and not stored. The risk of forming hypochlorous acid is practically nil in this case because we do not have the presence of the highly reactive ozone. In the next section the problem of ozonated saline will be discussed. In spite of some uncertainties, it is believed that this approach deserves to be pursued because it has potential advantages:

- Ozone generators, with all their problems and cost, would become superfluous. *Electric energy is unnecessary.*
- The cost of the “glucose or saline peroxide” solution is almost negligible. Preparation of the solution is simple, well standardized and reliable, and the solution is far more stable than ozone. Moreover, it can be transported and can be administered everywhere.
- One needs reagent grade H_2O_2 (30%), sterile bidistilled water, either a 5% glucose solution or sterile physiological saline and a few plastic disposable tools. The advantage is that the therapy can be performed in poor countries in the most remote corners of the Earth, particularly to alleviate some diseases. I will do the best I can to promote its application by the WHO, which has overlooked this possibility.

In 1993, Dr. Farr reported that injection of a 0.03% H_2O_2 solution into joints and muscles relieved pain quickly. This paradoxical result is similar to the one I will discuss with ozone injection (Orthopaedic diseases, [Section 9.13](#)). The Ethical Committee of Siena University approved my protocol for the IM administration of a 0.03–0.09% solution (8.8–26.4 mM H_2O_2). Preliminary results have shown that these concentrations are suitable (depending on the patient’s reactivity) for IM injection (5 ml per site) into trigger points present in paravertebral muscles, as a substitute for gas injection (O_3 at 20–25 mcg/ml), in patients with backache. The effect of so-called “chemical acupuncture” with $\text{O}_2\text{-O}_3$ is attributed to the local release of hydrogen peroxide acting on nociceptors and eliciting the analgesic response. This study has the scope to clarify the role of H_2O_2 as an “antinociceptive” drug but, after many promises, it was never started.

Besides the glucose-saline peroxide solution, there are two other potential possibilities of blood substitutes:

- (a) Fresh frozen plasma (FFP);
- (b) A lipid emulsion made of medium- and long-chain fatty acids and phospholipids, currently used for total parenteral nutrition.

After blood, FFP seems a reasonable solution because it contains all the basic reactants preferred by the solubilized ozone. However, as blood cells are absent, the formed H_2O_2 will not diffuse into them and will not activate important metabolic pathways *ex vivo*. As it is described in [Chapter 4](#), H_2O_2 will be reduced in 1–2 min after ozonation and the infused plasma will contain LOPs and will have a reduced (minus of 30–40%) antioxidant capacity. It is unlikely that it will be as effective as ozonated blood. Yet perhaps, if alternated with the glucose-saline-peroxide solution, it may represent a good compromise. However, while the glucose-peroxide solution is sterile, FFP can still transmit infections, in spite of a highly reduced risk. To enhance its validity, FFP should be obtained after strict screening and appropriate controls only from leukocytes-depleted blood. Moreover, it should be subjected to one of the currently used and expensive methods to ensure viral inactivation, such as solvent-detergent or methylene blue treatment, unless the ozonation process has an equivalent potency, an unlikely possibility on the basis of a recent study (Burgassi et al., 2009). Even so, there remains the huge problems of the availability of FFP as it is widely employed to obtain precious plasma components and of the Health Authorities's permission.

The final option is a lipid emulsion. There are several already employed for parenteral nutrition. Indeed we have spent some time evaluating one, which I will simply indicate as LE, rich in phospholipids, partly unsaturated medium and long-chain triglycerides, glycerol and water. It is isotonic, practically ion-free and obviously sterile. When exposed to O_2-O_3 , ozone dissolves as usual, reacts immediately with PUFAs and forms ROS and LOPs, which by mixing with blood during reinfusion may at least partly activate blood cells. Thus, it shows advantages and is a promising solution. After obtaining permission from the Ethical Committee and the Ministry of Health in April 1998, we conducted a preclinical study to assess the toxicity in rabbits (manuscript in preparation). Initially, we investigated which ozone dose (20, 40, 60, 80 mcg/ml) would be most suitable for the ozonation of LE. More recently, we examined the effect of 5, 11 and 21 treatments (within 56 days) (slow infusion via the ear marginal vein) of LE exposed to oxygen-ozone or only oxygen. Results showed that a medium ozonation (40 mcg/ml of LE) significantly enhanced (in comparison to control) the animal's body weight (mean increase of 550 g). Haematological parameters, TBARS, PTG and TAS plasma levels did not show abnormal variations. Histological examinations performed at the end of the experimental period on many organs from each rabbit group failed to show any pathological variations.

We are now characterizing the complex chemical change in composition of LE after ozonation. This line of research is interesting and we will take a step forward if we can use ozonated LE in patients, thus avoiding the problem of blood handling. Moreover, I envisage the possibility of dissolving a precise volume of filtered 15% H_2O_2 solution directly in the LE, thus excluding the use of ozone and extending its therapeutic use to poor countries. This study is in progress in our laboratory because we feel it is important to develop a useful possibility for patients who are not treated today. **I would like to remind that only about 20% of the world population**

receives proper medical attention and we ought to make an effort to help the remaining majority.

6.3.1 The Problem of Using Ozonated Saline

In 1994, we were the first to demonstrate that ozonation of medical physiological saline (0.9% NaCl) with various ozone concentrations (50–70–100 $\mu\text{g/ml}$ ozone) started to induce immediately and simultaneously formation of hydrogen peroxide and chemiluminescent effects indicating the generation of free radicals (Bocci et al., 1998a). The production of H_2O_2 is progressive and by using an ozone concentration of 100 $\mu\text{g/ml}$ yielded a high value after 60 min ozone insufflation. Infusion of 250 ml of this solution in healthy volunteers, myself included, caused considerable pain along the venous path of the infused arm after about 24 h. This alerted us that the solution have irritated the endothelium with the risk of a phlebitis and we were concerned that besides H_2O_2 , a transitory formation of HOCl^- may be the noxious agent. Although chloride is not oxidized by ozone, the saline solution may contain a trace of Fe^{2+} and the Fenton's reaction may occur:



Then at a pH below 7.0 the reaction

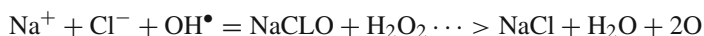

takes place (Shiozawa, 2000). Hypochlorous acid constitutes an inflammatory agent of the endothelium during an infusion, even at a concentration lower than 10 μM . Moreover it may activate platelets and induce a microcoagulation. Although it is well known that OCl^- , catalized by myeloperoxidase, is produced by phagocytic cells and it is an efficacious bactericidal compound, it remains well confined in phagosomes. However, OCl^- is one of the most damaging reactive oxygen species (ROS) during a chronic inflammation. When in Summer 1995 I went to Nizhny Novgorod for a conference, I had a heated discussion with a physicist, who was sure, without any official data, that ozonated saline was clinically as effective as major AHT.

The practice of using ozonated saline has become common in Russia and is widely employed because it is rapid, inexpensive, less time-consuming than major AHT and simultaneously applicable to many patients. Apparently in Russia they have too many patients and no sufficient facilities to perform an appropriate therapy. It is unfortunate that unscrupulous physicians have started to use it also in India, Indonesia, Italy and Greece. Ikonomidis et al. (2005) maintain the saline solution under a constant flow of ozone during transfusion but they warn that the maximum amount of ozone daily administered is usually 4–5 mg and should never exceed 8–10 mg. In their publication they also state “if we exceed these rates, the over

coagulation syndrome starts” and they strongly recommend to perform coagulation tests before starting therapy. Moreover Foksinski et al. (1999) by infusing 500 ml of ozonated saline in arteriosclerotic patients have determined the presence of 8-oxodeoxyguanosine, a typical oxidative DNA damage in lymphocytes. This marker is absent in patients treated with the classical ozonated AHT. These results reinforce our preliminary objection to this approach. To the best of our knowledge, Russian physicians ozonize the saline with very low ozone concentrations (2–3 $\mu\text{g/ml}$) and this precaution may reduce toxicity. Moreover they do not continue to bubble ozone in the saline during infusion that certainly would contribute to continuously generate HClO. This is important because the oxidation potentials of ozone is as high as 2.08 V while hydrogen peroxide has an OP of 1.78 V. Thus a continuous bubbling of ozone, while perfusing the saline, facilitates the formation of HClO that, although unstable, may be infused. *Clinical advantages have been claimed only by unscientifically saying that it is useful in all diseases but results have never appeared in peer-reviewed journals; thus there is a concern that the claimed advantage is due to a placebo effect not to be compared with the therapeutic effects of properly ozonated blood.* In contrast to ozonated saline, 0.03% (9 mM) H_2O_2 in isotonic glucose solution (5%), which does not contain traces of OCl^- have been safely infused (Bocci et al., 2005). Obviously, this solution should not be used in diabetic patients but the same concentration of hydrogen peroxide can be simply dissolved in medical saline and slowly infused. In such a case the risk of formation of HClO is nil because the strong oxidant ozone is absent. In any case these solutions are a palliative in comparison to the appropriate major AHT and they can be done only in emergency or lack of venous access. I felt the duty to mention this problem because unknowledgeable physicians may believe that is useful, quick to perform and remunerative but if they uses ozone concentrations higher than 3 mcg/ml, they can seriously damage the patient. The danger of damaging the endothelium and provoking an intravascular coagulation should convince everyone to proscribe the infusion of ozonated saline. By considering that the FDA and World Health Authorities are objecting the use of ozone in medicine, our aim is to use the most effective and safe method rather than comparing the doubtful Russian method to the safe European one.

6.3.1.1 The Intravenous Infusion of Ozonated Water

Recently, a new technique based on a central vein infusion of ozonated water has been proposed and tested in a few cancer patients. It is also unfortunate that the definition of either “liquid polyatomic oxygen” infusion or “ozone in liquid form” has been used. The definition is wrong because liquid ozone at ordinary pressure conditions exists at below -111.9°C , and it cannot be infused. Moreover, the term polyatomic oxygen is an euphemism because by the corona-discharge method practically only ozone is generated. Theoretically, even if a trace of polyatomic ozone (O_6 , O_9) are formed, they are practically irrelevant and decompose immediately into O_3 . It has been stated to perform a continuous administration for months of a mixture of “liquid polyatomic oxygen” useful for boosting the activity of some

cytotoxic drugs. As we have already mentioned both ozone and oxygen are physically soluble in pure bidistilled water. When the gas mixture composed of oxygen (95%) and ozone (5%) is bubbled in pure water, ozone in relation to its relative pressure, temperature and solubility coefficient will dissolve as a gas in the water and will saturate it within 5 min up to 26% (Masschelein, 1996). However ozone, even if kept in a tightly-closed ozone-resistant container spontaneously will decompose to oxygen during the following 11 h at +20°C. If the container is worn by a patient at the body temperature, ozone decays rapidly and the half-life is about 2.5 h but this disadvantage, however, has not been mentioned. Provided that the gas mixture is dissolved in pure water at ordinary pressure, it is theoretically possible to infuse water-dissolved oxygen and ozone VERY SLOWLY into the blood circulation. To the best of our knowledge, this technique had been firstly used by Belianin (2000) in order to decrease the resistance of multiresistant mycobacteria in TBC patients. This is a technique for ozone administration probably less dangerous than the direct IV administration of gas correctly prohibited in 1984, owing to serious side effects and the frequent risk of oxygen embolism. However, it appears obvious that the infusion of “liquid polyatomic oxygen” will catastrophically freeze the blood and why this term should be proscribed.

The proposed technique presents several disadvantages: firstly, there is no documented proof that a continuous deliver of solubilized ozone in pure water into the central venous system is more effective than the classical, practically risk-free, infusion of blood ozonated *ex-vivo* into a cubital vein. Even in skilled hands, complications such as pneumotorax and sepsis are low but do happen. Venous thrombosis is also a risk always well emphasized by expert anesthesiologists. Noticeably, the patient must accept the central implantation procedure and sign an informed consent (Bocci et al., 2008). In order to prevent a pathological haemolysis (at the tip of the catheter, local hypotonicity cannot be lower than 100 mM NaCl) and in consideration that cancer patients undergo a chronic oxidative stress, we cannot infuse more than 360 ml (depending upon the body weight) of pure water during 24 h. In other words, water can be cautiously infused at a rate of 0.50 ml/min. By using the currently available ozone generators, 360 ml of water at 20°C may dissolve no more than 9.3 mg ozone. However, as ozone decomposes rapidly at about 30°C. It is likely that, at best, we can deliver a negligible amount of oxygen and no more than about 6 µg/ml ozone per min. Thus the daily dose of ozone is below the average dose of 8.0 mg administered by ozonating 200 ml of blood *ex vivo* with an equal volume of gas containing 40 µg/ml ozone. This reasoning questions the validity and usefulness of the direct infusion of water-soluble ozone, also because the gas will immediately react with blood and it will never reach and kill neoplastic cells *in vivo*.

6.3.1.2 Is the Ascorbate Saline Solution a Possible Substitute of Ozonotherapy?

Thus, at the end of this *Via Crucis*, we still have to find an alternative safe and effective solution to be infused in patients without the problem of collecting blood.

It is worth while to analyze the validity of a physiological saline containing ascorbate (Vitamin C) as the generator of hydrogen peroxide and an effective substitute of ozone. Our aim deeply differs from Levine et al. (2009) studies in assuring an important role to ascorbate in cancer treatment. His line of research is certainly important but we are searching a solution that will avoid the need of an ozone generator and the problem of blood collection. *Ascorbate, at a high dosage, has the peculiar capacity to act as a pro-oxidant by generating in vivo hydrogen peroxide, as a ROS, and ascorbyl radicals (Asc^{•-}) as an unusual LOP* (Mouitys-Mickalad et al., 1998), that may be able to alert the organism of a transitory, small oxidative stress able to induce the upregulation of antioxidant enzymes. A pharmacological dose of 10 g daily (about 166-fold higher than the recommended daily allowance, RDA) infused intravenously will yield a plasma concentration of 5–6 mM that are about 25-fold higher than the one measured after oral administration of 10 g ascorbate. Clearly the oral route is useless for several reasons and only the IV infusion is able to raise the ascorbate concentration in the plasma to allow a rapid and conspicuous transfer into the interstitial fluid, thus allowing the formation of hydrogen peroxide and ascorbyl radicals. While hydrogen peroxide formation in blood is very transitory and may have only a minimal effect on circulating blood cells, its far higher concentration in interstitial fluid, by continuously returning and mixing in the blood pool, will be sufficient to amplify the desired biochemical stimulation, possibly expressing an equivalent ozone-like effect on the organism (manuscript in preparation). It is impellent to initiate experiments in volunteers to evaluate not so much a variation of the antioxidant status but the likely modifications of oxidative stress markers. Hopefully a dose of 10 g ascorbate may suffice because the high dosages (50–80 g) necessary for cancer therapy are not suitable for a treatment that may yield similar results as major AHT. If this will be the case the ascorbate solution may be useful in vascular diseases, diabetes, ARMD and also in chronic infectious diseases owing to bactericidal activity and the stimulation of the immune system. Thus ascorbate infusion has the potential of substituting or complementing all the preceding solutions such as the glucose-saline-peroxide, the ozonated saline and the ozonated water. The latters have disadvantages such as toxicity and scarce efficacy because hydrogen peroxide in blood is reduced in a matter of seconds. Ascorbate is unstable too and 10 ampoules of the medical-ready compound (1 g/ampoule) will be dissolved in 200 ml of sterile saline and used at once, probably performing 2 or 3 treatments weekly in patients with the above mentioned pathologies.

I feel the duty to mention that the intuition of using very large doses of vitamin C for treating infectious diseases must be attributed not to a scientist but to C. Frederick R. Klenner, a medical doctor practising in Reidsville, NC, USA. During the 1948 polio's epidemic he treated 60 patients with 6–20 g of ascorbic acid every day until a definitive improvement. Although he published the results in the *Southern Medicine and Surgery* (July, 1949), official medicine neglected his results probably because not achieved with a vaccine. He also treated other serious infections by administering up to 22 g of vitamin C every 12 h with a complete cure. On this basis it appears that ascorbate infusions, possibly alternated every 4 h with

0.06% hydrogen peroxide may be attempted as the last resource in case of severe sepsis insensitive to antibiotic-resistant bacteria.

The need of evaluating other solutions arises from three basic difficulties of ozonotherapy: the first is the use of medical ozone that, although incorrectly, is still objected by the medical establishment. The second is the need of a reliable but expensive ozone generator, of medical oxygen and of a specialized physician in ozonotherapy. The third is the great difficulty of domiciliary treatment that is almost the rule of orthodox medicine. Thus, in this chapter, we have examined several methodologies for overcoming these problems. At this stage only the glucose or saline peroxide solutions or the just proposed ascorbate solution have, at a different extent, the capacity of overcoming these problems. During the next few years we will clarify which is the best solution.

6.4 Rectal Insufflation of Oxygen-Ozone (RI)

Payr and Aubourg, in 1936, were the first to suggest the insufflation of this gas mixture into the colon-rectum and today this approach has been fully adopted at Cuba because it is easy to perform, is inexpensive, practically risk-free, perhaps beneficial in people, who do not object to rectal medication. In several states of the USA, where ozonotherapy, owing to misuse by quacks, has been prohibited, many HIV patients used to do their own auto-insufflation using an often imprecise portable ozonator. In California, Carpendale et al. (1993) were allowed to perform a study in AIDS patients with profuse diarrhoea due to opportunistic *Cryptosporidium* infection; as it was expected, they reported only a temporary improvement in some of the patients. Carpendale was a clinical scientist and not a quack; I am glad to have talked with him in San Francisco and he was honest in saying that he used ozone as a last resort in desperate patients: The diarrhea diminished but there was no cure.

The main field of application is represented by rhagases, anal and rectal abscesses with fistulae, proctitis, bacterial and ulcerative colitis, Crohn's disease and chronic B and C viral hepatitis. Even ischaemic diseases and dementias have been treated with RI, which was postulated to have a systemic effect. Indeed a surprisingly rapid systemic effect seems supported by recent studies in the rat (León et al., 1998; Barber et al., 1999; Peralta et al., 1999, 2000; Borrego et al., 2004; Gonzalez et al., 2004), in which it was shown that RI for 2 weeks induced adaptation to chronic oxidative stress.

In spite of the fact that hundreds of thousands of treatments are performed every year, it was unclear whether and how these gases could affect some physiological, biochemical and immunological parameters. Although mainstream medicine, as usual, scorns this empirical treatment, I felt that it was important to address the following questions:

- (1) Are oxygen and ozone absorbed by the intestinal mucosa?
- (2) Does RI have only local effects or systemic ones as well?

- (3) Bearing in mind the toxic effects of ozone on the respiratory tract, we must ascertain if ozone negatively affects the intestinal mucosa.

Knoch et al. (1987) examined the PvO₂ modifications after rectal insufflation in the rabbit. They found increased oxygen content of 230, 121 and 127% in a mesocolonic vein, portal vein and liver parenchyma, respectively, 8–20 min after rectal insufflation of 150 ml of gas. The values returned to baseline after 50 min. This result is not new because we know that several gases, such as carbon dioxide, methane, hydrogen, oxygen, nitrogen and hydrogen sulphide, either ingested or produced by the bacterial flora are partly absorbed or excreted or even exhaled with expired air. Obviously we are interested in the fate of ozone introduced in the gut lumen. In Chapter 4, it has been clarified that ozone, firstly dissolves in water but, unlike oxygen that freely diffuses into other compartments, reacts immediately with any biomolecule, particularly PUFA producing ROS and LOPs. Thus we can determine the fate of ozone by measuring LOPs in the intestinal-portal and peripheral circulation. While the respiratory mucosa is overlaid by a very thin and hardly protective film of fluids, the gut mucosa is abundantly covered by the glycocalyx and a thick coating of water containing mucoproteins and other secretion products with potent antioxidant capacity (Halliwell et al., 2000). Besides this gel-mucous layer, a variable faecal content is present and can markedly quench the oxidant activity of ozone. It becomes clear that **this unpredictable parameter represents the weak point of RI because we cannot ever be sure of the ozone dosage really available**. However we felt worth while investigating in the rabbit whether ozone has, through the LOPs either a local, or/and a systemic activity. Results have been enlightening and have reported in extenso by Bocci et al. (2000) and Bocci (2002).

It suffices here to sum up the following data:

- (1) After rectal insufflation, **we measured an increased oxygen content both in the portal vein (20–35 min later) and in the jugular vein (35–40 min later)**. There were no significant variations of PvCO₂ and pH.
- (2) Concomitantly, there was **a constant increase of LOPs' values up to 60 min after gas insufflation**, when they started to decline. **Values were markedly higher in the portal than in the jugular blood due to dilution in the general circulation**. Conversely, values obtained by measuring oxidation of protein thiol groups showed an opposite trend, i.e. reached a minimum after 90 min. Both parameters returned to baseline 24 h thereafter.

Therefore, it appears that RI can exert a local and a rapid systemic effect due to absorption of ROS and LOPs generated by the interaction of ozone with biomolecules present in the luminal content. The quantity of absorbed ROS and LOPs are however unpredictable due to the variable content of luminal, mainly faecal material.

Figure 6.2 suggests that ozone dissolves rapidly in the luminal water, but, in comparison to oxygen, it is not absorbed because it partly reacts with mucoproteins lining the mucosa, partly may react with fecal material and partly can be reduced

Fig. 6.2 A schematic view of the transfer of the O_2 - O_3 gas mixture from the colonic lumen into the submucosa. Both gases dissolve in the luminal mucous layer, but ozone reacts immediately and decomposes into a number of ROS and LOPs. These are absorbed with water via venous and lymphatic capillaries in the submucosa below the muscularis mucosae (MM)

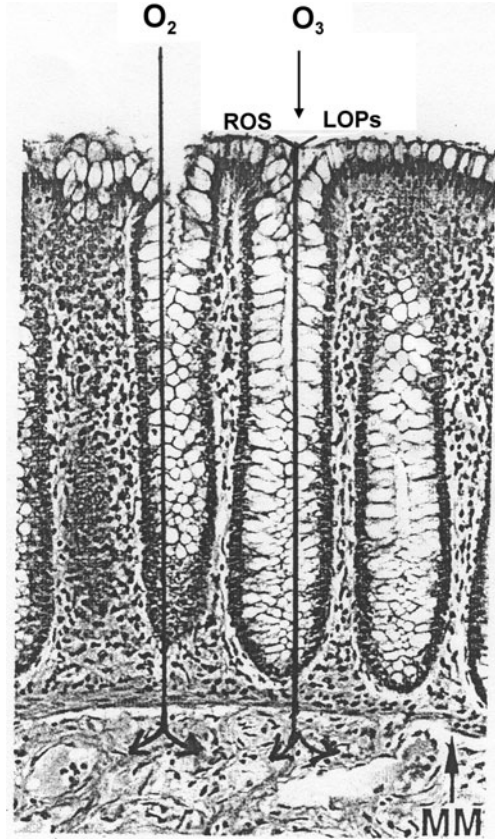

by antioxidants. LOPs, like oxygen, pass through the muscularis mucosa (MM) and enter the circulation via lymphatic and venous capillaries. **This conclusion** is relevant and **would support the contention that the beneficial effect of RI in chronic limb ischaemia may be similar or equivalent to major AHT. If this result can be confirmed in a controlled, randomised clinical trial, it will be helpful for patients because they will be able to do automedication and avoid repeated venous punctures.** Moreover it does explain why prolonged (up to 13 weeks) RI in aged subjects causes a modest increase of both ATP and 2,3-DPG in erythrocytes (Viebahn-Hänsler, 1999a, b). These results are the more surprising because, in comparison to the precise volumes and ozone concentrations in major AHT, we know very well how imprecise the application of ozone can be and particularly the volume of gas retained and effectively acting in the gut lumen.

This leads to the discussion of some technical details in terms of gas volume, ozone concentration and schedule of administration. **RI should be done after defecation or after an enema, when the rectal ampulla is empty.** The patient must

lie on one side and try to relax; often he/she prefers to personally insert the disposable, oil-lubricated polyethylene or silicone (rubber must never be used) catheter (30–40 cm long). The insertion is easy and it should not stimulate peristalsis. To this end, the gas has to be introduced slowly and in steps of 50–100 ml every 1–2 min. If it is done quickly, the gas will be expelled at once. The gas can be introduced via: (a) a manual two-way silicone pump connected to the gas just collected in a polyethylene bag, or with (b) a 50 ml silicone-coated syringe, clamping the catheter with a Klemmer each time after insufflation. We can obtain good compliance if we start with 150 ml and slowly scale up to about 400–500 ml depending on the patient's tolerance. This volume can easily be retained for at least 20–30 min. Knoch et al. (1987) insufflated up to 800 ml in 1 min, but I cannot confirm this and it is likely that the patient would rapidly expel most of the gas. Carpendale et al. insufflated from 700 to 1,300 ml of gas (up to 30 mg ozone daily) in AIDS patients, hoping the gas would diffuse into the whole colon. This was a desperate, almost useless enterprise because *Cryptosporidium* contaminates the whole gastrointestinal and bile ducts. The patient should be left to rest for at least 15 min after RI to avoid rapid gas expulsion and to allow the reaction of ozone with the luminal contents.

The ozone concentration is important to induce local and generalized effects but there is a general consensus that it should not exceed 40 mcg/ml.

Cuban physicians have selected to administer in diabetic patients 200 ml gas with an ozone concentration of 50 mcg/ml (dose 10 mg), that I consider too high. In my experience, this concentration often elicits painful cramps, particularly in patients with ulcerous cholitis or when the application is done after an enema, suggesting a dangerous stimulation of the local gut reflexes. If the overlaying mucus has been washed away, this high concentration might cause direct damage to the enterocytes and we should not forget that ozone is potentially mutagenic. Thus I suggest beginning treatments with 3–5 mcg/ml and slowly scale up to 30 mcg/ml if the patient tolerates it well. It has been written (D'Ambrosio, 2002a) that, in the case of haemorrhagic ulcerative cholitis, an ozone concentration of 70–80 mcg/ml should be used for haemostatic purposes, but this could induce cytotoxic damage and it can be done only in emergency. Moreover, on the basis of the concept of inducing ozone tolerance, it appears reasonable to reach the concentration of 35 mcg/ml only in the last week. Whether it is worthwhile reaching the highest ozone concentration of 40 mcg/ml will depend on the type of pathology, patient tolerance and other information that can only be obtained by daily observations during a well controlled clinical study. Treatment can be done daily or every other day. Table 6.1 provides an example of a flexible schedule.

If the patient responds positively to the therapy, it could be continued 2–3 times per week, maintaining a high or medium ozone concentration. Although I am not enthusiastic of the IR approach because the effective ozone dose is never known due to the fecal contents and other variables, I admit that **it is the simplest and most practical option to be adopted in poor countries. In order to prevent cross contaminations, the catheter and syringe must be disposed of after each treatment.**

Table 6.1 A possible schedule of ozone administration by RI

| Weeks | Days | Concentration O ₃ (mcg/ml) | Gas volume (ml) | Total Ozone dose (mg) | Range |
|-------|------|--|--------------------|--------------------------|-------------|
| 1 | 1 | 3 | 100 | 0.3 | Low-medium |
| | 3 | 5 | 150 | 0.75 | |
| | 5 | 8 | 200 | 1.6 | |
| 2 | 1 | 10 | 200 | 2.0 | |
| | 3 | 10 | 250 | 2.5 | |
| | 5 | 15 | 250 | 3.75 | |
| 3 | 1 | 20 | 300 | 6.0 | Medium-high |
| | 3 | 25 | 350 | 8.75 | |
| | 5 | 30 | 400 | 12.0 | |
| 4 | 1 | 35 | 400 | 14.0 | |
| | 3 | 35 | 400 | 14.0 | |
| | 5 | 35 | 400 | 14.0 | |

If, by an appropriate randomized clinical trial (RCT), we can prove that IR also has therapeutic activity in vascular disease, chronic hepatitis and intestinal diseases, we will have to promote RI, as the Cinderella of approaches, to the rank of AHT. Moreover the possibility of an easy and safe automedication by the patient at home for prolonged periods cannot be underestimated. Sixty-six years after the introduction of RI and after millions of applications with no cause for complaint, we can say that this approach, if properly performed, does not seem to induce adverse local effects. It appears reasonable to think that a judicious ozone dosage, the mucous layer, the antioxidant system and the adaptive response of enterocytes are all responsible for the lack of toxicity. However we must keep in mind that Eliakim et al. (2001), after repeated enema in rats with ozonated water (20 mcg/ml), have reported the appearance of a microscopic colitis. Although gas insufflation is probably less irritating than the enema, this result reinforces my suggestion to use low doses of ozone at least initially for inducing the tolerance phenomenon.

In Chapter 9, we will briefly examine the pathogenesis of the diseases where RI is best employed, but here it may be useful to speculate about the local effects of ozone. These may be as follows:

- (a) *Biochemical effects.* In the studies already cited (León et al., 1998; Barber et al., 1999; Peralta et al., 1999, 2000; Borrego et al., 2004; Gonzalez et al., 2004), RI in rats upgraded the enzymatic antioxidant response in liver and kidney but the viability of enterocytes was not examined.
- (b) *Bactericidal effects.* The human colon-rectum contains up to 600 g of about 400 species of mostly anaerobic bacteria, and ozone may partly change the environment for a short while. Except in particular conditions, like clindamycin-associated enterocolitis (Schulz, 1986), bactericidal activity per se is probably unimportant but may cause the release of LPSs and muramyl peptides. These compounds are among the most potent cytokine inducers and in large amounts

are responsible for the toxic shock syndrome and likely death. However, in physiological conditions, the daily absorption of traces of LPSs bound to specific proteins and to lipoproteins is considered essential for maintenance of the basic cytokine response and an alert immune system (Bocci, 1981b, 1988c, 1992c). Particularly in the last paper, it was postulated that the somewhat neglected gut flora has a crucial immunostimulatory role. This idea remains valid today and it is possible that RI favours a slight increase of LPS absorption with the consequence of enhanced activation of intrahepatic lymphocytes, Ito's and Kupffer's cells (O'Farrelly and Crispe, 1999), which may change the evolution of chronic hepatitis.

- (c) *Modification of the bacterial flora equilibrium.* Owing to the multiplicity of bacterial species, this remains a complex area. However, the normal flora contains *Lactobacillus (Lb) acidophilus*, *Lb. bifidus*, *Lb. fermentum*, *Lb. casei*, *Streptococcus faecalis*, *S. thermophilus*, *S. bulgaricus*, *Escherichia coli*, *Proteus* and a variety of enterocci. The bacteria and their products interact with each other and with the enterocytes, goblet and enteroendocrine cells (producing a myriad of hormones) and the gut-associated lymphoid tissue, GALT (Hooper and Gordon, 2001). On the other hand, it is well known that contaminated food, water and antibiotics can subvert this dynamic symbiosis by allowing the establishment of pathological bacteria and fungi like *Candida albicans*, *C. tropicalis*, *Torulopsis glabrata*, etc. The successive dysmicrobism usually has far-reaching deleterious consequences, ranging from transient to chronic enterocolitis and to autoimmune reactions and therefore we must try to correct it in order to restore normal homeostasis. Whether RI with a daily input of oxygen-ozone can re-equilibrate the bacterial flora and lead to normal immunoreactivity remains to be demonstrated (and explained), although anecdotal results suggest a beneficial effect.
- (d) *Effects on the GALT.* The gastrointestinal compartment represents almost 40% of the whole immune system. Besides the famous plaques described by Johann Konrad Peyer (1653–1712), over a total intestinal surface of some 300 m², there are about 10¹¹ immunocytes per m² or about one per 6–7 enterocytes.

Intra-epithelial immunocytes are mainly T lymphocytes, either α - β of thymic origin or γ - δ of local origin. The latter induce a Th-2 type response that is anti-inflammatory and immunosuppressive, quite important to prevent excessive stimulation due to alimentary, bacterial, viral and toxic antigens. Perdue (1999) has emphasized that **a continuous cross-talk between immunocytes and enterocytes may maintain a healthy homeostasis and prevent breakdown of the mucosal barrier and inflammation.** In spite of interesting hypotheses (Fiocchi, 1998, 1999; van Parijs and Abbas, 1998; Okabe, 2001; Shanahan, 2002; Ardizzone and Bianchi Porro, 2002), the etiology and pathogenesis of both ulcerative colitis and Crohn's disease remain uncertain and it is difficult to identify the culprits that, step by step, cause the disease. Using the current paradigm of T-cell homeostasis, ulcerative colitis seems compatible with a poorly polarized Th-2 response or, in other words, with a lymphocytes T regulatory deficiency, while Crohn's disease is characterized by an

excessive Th-1 response. In other words, any alteration of the balance between pro-inflammatory (IL-1, IL-2, IFN γ , TNF α) and anti-inflammatory cytokines (IL-10, TGF- β) appears critical (Schreiber et al., 1995), and an excessive release of IL-4, which affects the enterocytes, also appears important in ulcerative colitis (Perdue, 1999).

Another piece of the puzzle is represented by a more or less adequate synthesis of Hereman's "protective vernix" i.e. A-type immunoglobulins (Ig) produced by plasma cells (B lymphocytes). IgAs have a critical role in neutralizing foreign antigens and this may limit the onset of an autoimmune process. Once this starts, the vicious circle is complicated by other cells, namely cytotoxic lymphocytes, monocytes, macrophages and granulocytes, and by the release of other inflammatory compounds such as ROS, proteinases, eicosanoids and platelet-activating factor (PAF).

During the last 20 years, official medicine has made a great effort to sort out this intricate problem. Yet still today Crohn's disease remains a serious affliction. D'Ambrosio (2002a, b), in an open study, has shown that RI can lead to a marked improvement of these affections. If his results could be confirmed, no patient should miss this opportunity and we ought to present a rational basis for using ozonotherapy. Table 6.1 shows a possible treatment scheme that could be adopted for a randomized clinical trial. Intuitively I feel that the local treatment should be combined with 2–3 AHTs weekly, plus a supporting therapy with antioxidants, probiotics and omega-3 PUFA. It will be important to perform at least a pilot trial and investigate whether AHT coupled to RI will be able to re-equilibrate the immune response and lead to normal mucosal metabolism. Official medicine is really struggling to find an effective treatment as critically examined by Hanauer and Dassopoulos (2001), who have reviewed pros and cons of as many as twenty possibilities. In Section 9.5, there is an ample discussion regarding the novel therapy with antibodies to TNF alpha.

Finally by remembering that the gut is the largest endocrine organ in the body and our second brain, as it contains billions of secretory neurocytes (Ahlman and Nilsson, 2001), it is possible to speculate that we could use both RI and major AHT if we could influence or better normalize the neurosecretion of relevant neuromodulators, which may be responsible of irritable bowel. Spastic colon is a difficult chronic illness with a high societal cost, which affects the quality of life of many people stressed by daily circumstances.

6.5 Quasi-Total Body Exposure to Oxygen-Ozone (BOEX)

Some 14 years ago, we raised the possibility of exposing the body (excluding the head and neck to avoid pulmonary toxicity) in an ozone-resistant container (a large polyethylene bag would be a poor solution) for patients who refused rectal insufflation and for those who had a poor venous access for major AHT (Bocci, 1996b, c). The problems inherent in this approach are discussed here.

- (1) *Is ozone as toxic for the skin as it is for the respiratory mucosa?* (Lippman, 1989; Kelly et al., 1995) In common with ozone, chronic UV irradiation of the skin generates ROS, which after life-long exposure can result in skin changes such as wrinkles, pigmented spots and possibly cancer. Further studies have shown that both ozone treatment and UV-irradiation of epidermal layers of murine and human skin cause peroxidation and depletion of vitamins C and E (Thiele et al., 1997a, b; Podda et al., 1998; Fuchs and Kern, 1998; Valacchi et al., 2000, 2002, 2003). It has also been shown that these oxidizing agents, hence ROS and LOPs, activate NFKB and activator protein-1 (AP-1), but that alpha-lipoic acid (LA), n-acetyl-cysteine (NAC), Thioredoxin (Trx) and Selenium can inhibit the activation to a large extent and induce adaptive protection, such as over-expression of MnSOD and GSHPx as a salutary response to oxidative damage (Haas et al., 1998; Saliou et al., 1999; Meewes et al., 2001; Didier et al., 2001). It is clear that the skin has a multiform antioxidant defence system, far more potent than that present in RTLF, and that it cannot be overwhelmed provided the attack by ozone or UV irradiation is not too harsh. These findings lend support to the empirical observation that **during topical ozonotherapy of necrotic ulcers, we have never noticed any damage to normal skin.** Moreover, during balneotherapy with slightly ozonated water, no local or generalized untoward effects have been reported.
- (2) *Are there anatomical-physiological reasons for the relative tolerance of skin to ozone?* Yes, if one examines the scheme of Fig. 6.3 owing the structure of skin, with the epidermis, the derma and the disposition of the vascular system. The most external layer is the stratum corneum, i.e. the end product of keratinocyte function, which is a compressed and tough layer. **This “dead layer” is more or less covered by a very dynamic film, containing some proteins, ions, lipids and water, due to the secretion of the eccrine glands.** It is partly responsible for thermoregulation, since it allows cooling of the skin surface (–580 cal/g) as the water changes from liquid to vapour. Moreover, the layer of lipids, produced by sebaceous glands, consists of unusual oily material, partly modified by the resident microflora (Nicolaidis, 1974); in our opinion, this represents the first line of defence against ozone and UV rays. Progressing towards the dermis, there are the stratum granulosum, the stratum Malpighi and the proliferating basal cell layer. The dermis and the subcutaneous tissue contain a very flexible vascular system with a heat-exchanger, represented by capillaries and mainly by the venous plexus associated with the opening of arteriovenous shunts. It is able to accommodate up to 30% of the cardiac output so that heat transfer through the skin can increase up to eightfold from a state of total vasoconstriction to extreme vasodilatation.
- (3) *A crucial question is: when the skin is exposed to oxygen-ozone, do these gases penetrate all the cell layers to reach the dermis and enter the capillaries?* It has been said that ozone reaches the blood circulation and has a cleansing effect, with the elimination of viruses and toxins. Yet this claim propagated by quacks is not correct and it has only commercial purposes. Only oxygen and carbon

Fig. 6.3 A schematic view of the skin and cutaneous circulation. Numbers indicate: (1) The stratum corneum overlaid by a superficial hydro-lipid film, in which ozone dissolves and generates ROS and LOPs. (2) Malpighi's layer. (3) The basal cell layer and basement membrane. (4) The dermis, with a sebaceous gland and a sweat gland. (5) The arterial and venous vasculature with arteriovenous anastomosis. (6) The subcutaneous fatty tissue

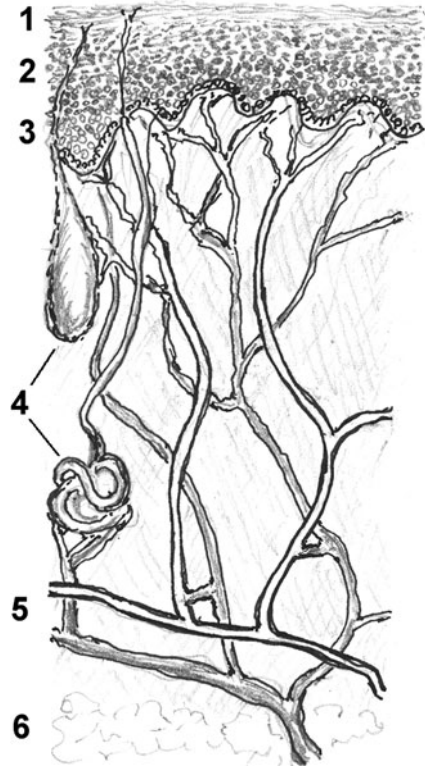

dioxide can move easily through cell membranes. However, **owing to its dipolar moment and high solubility, ozone dissolves in the superficial water film and reacts immediately with PUFAs of the sebum, generating ROS, hence H_2O_2 and an array of LOPs.** Therefore, it is more than likely that ozone does not even reach the phospholipids of the outer corneocytes, a conclusion already advanced by Pryor in 1992 for the pulmonary air-tissue boundary. However, the generated ROS and LOPs can be partly absorbed and pass through the epidermis, derma and capillary wall to enter both the lymphatic system and the blood stream (Fig. 6.4). Obviously hydrogen peroxide and other ROS have a very short half-life and will be quickly reduced; indeed it has been clearly reported that several antioxidants (vitamins E and C, etc.) are readily oxidized (Thiele et al., 1997a, b; Podda et al., 1998; Fuchs and Kern, 1998).

- (4) The obvious corollary that comes to mind is: *does skin vasodilatation enhance the transfer of O_2 , CO_2 , ROS and LOPs?* It certainly does and we will discuss some experimental results. The “thermal stress” that is easily induced with hyperthermia (Finnish and Turkish bath) increases cutaneous capillary perfusion, which may greatly increase the “perspiratio sensibilis” through activation of sweat glands and may also favour absorption of ROS and LOPs produced

Fig. 6.4 A schematic view of the fate of ozone in the skin during BOEX. Ozone dissolves in the water-sebum film overlaying the outer layer of the stratum corneum and reacts immediately with PUFAs, generating ROS (among which H_2O_2) and LOPs. These compounds can be partly absorbed and pass through the transcutaneous barrier, facilitated by the intense vasodilation induced by the hyperthermia. Both lymphatic and venous capillaries can rapidly transfer LOPs into the general circulation, thus inducing systemic effects. Numbers indicate: (1) The stratum corneum coated with a superficial hydro lipid film, in which ozone dissolves and generates ROS and LOPs. (2) Malpighi's layer. (3) The basal cell layer. (4) The dermis

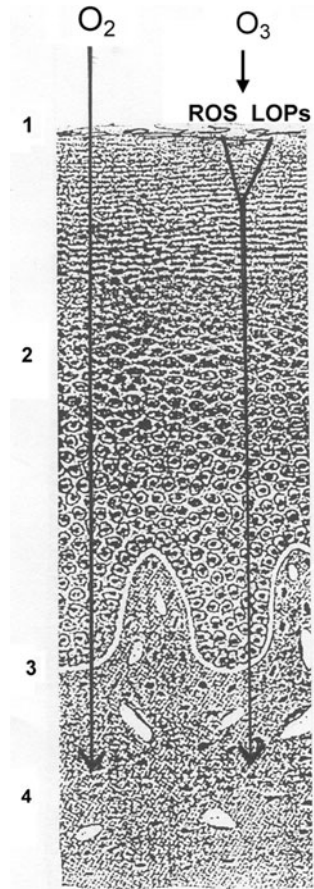

during an “ozonated sauna”. Around 1995, we were informed that beauty centres in Italy had used sauna bathing with a trace of ozone for a decade, but this had remained only in the realm of cosmetic treatment of lipodystrophy and obesity. Moreover, on October 10, 1997, we received a letter from Canada stating that steam sauna combined with ozone had come into widespread use and “well over 2,000 people had been treated with uniformly excellent results”. Apparently some terminal cancer patients had been cured!!! Needless to say, no scientific reports had been published. Nonetheless, in 1998, Dr. Emma Borrelli and I thought that the ozonated sauna might be another therapeutic option with the advantage of non-invasiveness, particularly important in patients with deteriorated venous access. We found an excellent place to perform our study: a thermal resort in the middle of the Dolomite Alps (Raphael Clinic at Roncegno,

Trento). We were lucky to have the enthusiastic collaboration of seven middle-aged physicians who acted as volunteers. The aim of our programme was to evaluate the following aspects:

- (a) **Possible variations of arterial and venous pO₂, pCO₂, pH, examined before (pre), immediately after (end) and then 0.5, 1.0 and 24 h after a period in a sauna cabin in the presence of either oxygen-ozone (May 1998) or only oxygen (control, September 1998).** Unfortunately, only venous pO₂ values were obtained because our colleagues objected to the arterial blood collection.
- (b) **Modifications of body mass, oral temperature, diastolic and systolic blood pressure and ECG pattern.**
- (c) One important question was **to examine any possible variations of peroxidative markers in plasma during and after treatment.** In other words, we wanted to ascertain whether a 20 min exposure to ozone of almost the entire cutaneous surface could induce an oxidative stress and, if so, if this would be tolerable and lead to a therapeutic benefit. All details can be read in the original paper (Bocci et al., 1999a, b).

The cabin was made of laminated plastic and, after subtraction of the body volume, had an internal residual volume of about 440 L. The flow of gas through the cabin (either a mixture of about 97% O₂ and 3% O₃ or pure medical O₂) was 1 L/min. The volume of gas must be limited for avoiding any risk of explosion. The ozone concentration was assessed in real time with a portable photometer. Any internal increase of barometric pressure in the cabin was prevented by an external silicone tubing connected to an ozone destructor. The maximum ozone concentration was reached at the end of the session and was estimated to be no higher than 0.90 mcg/ml, i.e. many times lower than the minimal ozone concentration used during local treatment of torpid ulcers for the same period (Werkmeister, 1995). Steam was generated in the cabin by a thermostatically controlled heater set at 90°C and turned on 10 min before the subject entered the cabin. Two towels and one polyethylene sheet were wrapped around the subject's neck to prevent breathing ozone. Although the doors were tightly closed by means of ozone-resistant gaskets, they were further insulated with the polyethylene sheet and towels to avoid any leakage of gas into the room. Our initial cabin was rather primitive but at the 1st Turkish Congress of Ozonotherapy at Istanbul (December 4–6, 2009), I was impressed by the exhibition of a many as three different and perfectly built ozone-resistant cabinets.

In our study, the session lasted 20 min, during which the maximum temperature inside the cabin reached 46–50°C with a humidity of 100% comparable to a Turkish bath. Just before the doors were opened, the gas flow was interrupted and the internal gas was rapidly aspirated via the outlet to prevent any breathing of ozone by the subject and the assistant. Determination of several variables was performed before, immediately after, and then 0.5, 1.0, 24 h after the session. Body (oral)

temperature was also measured in the middle of session. Standard 12-lead electrocardiograms were recorded before and after the session. Body mass was assessed with an electronic balance with an error of ± 50 g. Blood gas analysis was performed with a standard blood gas analyser. Systolic and diastolic arterial blood pressures were measured with a standard cuff sphygmomanometer.

Each volunteer (age: 33–41 years) was subjected to one 20-min exposure in the water vapour-saturated cabin, in the presence of either oxygen-ozone or oxygen only, i.e. he served as his own control.

There was a significant increase in body temperature, which reached a peak at the end of the treatment and declined rapidly thereafter. The maximum oral temperature ranged between 37.5 and 39.3°C. There was a concomitant reduction in body mass (200–600 g). Similarly, blood pressure decreased slightly, but recovered within the next 30–60 min.

There was **a significant increase of PvO₂ and decrease of PvCO₂ at the end of the session and for 1 h after exposure to either oxygen-ozone or oxygen alone**; the increase in PvO₂ after exposure to oxygen alone was not significantly higher than that after exposure to both gases. The increase of PvO₂ was highly significant because indicated that oxygen had been absorbed via the skin. Values for both erythrocytes and haematocrit increased immediately after the 20-min exposure. They decreased thereafter, probably due to rehydration, and were almost normal after 24 h

We noted **an initial significant increase in leukocytes**, followed by a decrease 1 h after oxygen-ozone exposure.

The experimental data regarding the plasma levels modifications of total antioxidant (TAS), peroxidation values measured as Thiobarbituric Acid Reactive Substances (TBARS) and protein-thiol groups (PTG) oxidation were quite surprising: **antioxidants declined but remained at a substantial level, peroxidation levels increased steeply, in a linear fashion up to an hour after the end of the session while protein-thiol groups declined during the same period**. Obviously absorption of peroxidation products is very fast and intensive through the skin during the 20 min exposure. All values returned to the baseline 24 h thereafter and, in spite of the peroxidation increase, **no haemolysis was noted at any time**. Interestingly, even the exposure to oxygen alone induced a similar trend, although modifications of plasma levels were less marked.

We also investigated whether the plasma levels of three representative markers changed after the O₂-O₃ exposure. **Levels of IL-8 significantly increased 30 min after exposure**. Conversely, levels of myeloperoxidase (MPO) and transforming growth factor (TGF-beta1) either did not change or tended to decrease.

Plasma levels of hepatic enzymes and creatinine remained within the normal range. The interested reader can examine the diagrams and numerical data in the original publication (Bocci et al., 1999). All subjects tolerated the exposure to either gases or oxygen alone without reporting immediate or subsequent adverse effects. Oral intake of water was allowed at the end of the sauna. Four subjects enjoyed the sauna, but two reported that they would find it difficult to tolerate a period longer than 20 min in the cabin. Almost needless to say that this was an experimental study,

while patients, depending upon their pathology and stage of disease, would undergo far milder conditions. If the temperature inside the cabin is regulated at 37°C, one could prolong the therapy up to 30 min.

Although this preliminary study had some pitfalls, it was informative but it will be useful to examine the relevance of hyperthermia. Depending upon the initial temperature of the cabinet, one must consider that the body's internal temperature of any individual begin to rise after the initial 10–12 min permanence. Moreover we could have examined the effect of the hyperthermia alone, which in itself is quite interesting. We enjoyed reading a recent review on the “Benefits and risks of sauna bathing” (Hannuksela and Ellahham, 2001). Unlike the Turkish bath (45–48°C and humidity at about 100%), the sauna has a temperature ranging between 80 and 100°C at the level of the bather's face and 30°C at floor level and a relative humidity of about 20%. One good point of our study was to control the same subjects with oxygen alone. **Insufflation of oxygen alone is indeed able to increase peroxidation during the hyperthermic period.** The results are even more surprising if we consider that the gas flow was only 1 L/min and thus the total volume of 20 L of oxygen was diluted in about 440 L of air contained in the cabin. This suggests that **the heating per se must overwhelm the effect of oxygen alone.** However, **ozone clearly accounts for the significant linear increase of peroxidation values measured up to an hour after the session.**

Let us examine the risks: firstly, ozone toxicity for the respiratory tract. There must be neither contamination of environmental air with ozone, nor any ozone inhalation and we took precautions to avoid that. The cabin must be tightly closed, the room must be well ventilated, the gaseous contents of the cabin must be quickly aspirated before it is opened and a monitor sensing the ozone level must be on all the time.

Secondly, ozone toxicity for the skin. Depletion of antioxidants and the increase of malonyldialdehyde (MDA) in the outer epidermal layers are well documented, but in our study the final ozone concentration in the cabin could reach at most 0.9 mcg/ml by the end of the 20 min session. The final ozone concentration increases slowly because we must take into account the large dilution with a slight loss because the cabin remains at normal pressure and the rapid ozone decay at about 40°C (about 18 min). Thus the final concentration is about 10–20 times lower than that used during the final topical applications in skin ulcers or decubitus (Werkmeister, 1995). In conclusion, **we did not observe any acute or chronic toxicity.**

Thirdly, systemic toxicity of ozone. We had no direct information about this **but, as ozone reacts immediately on the liquid film layered on the cutaneous surface, only some of the generated ROS and LOPs might be absorbed and enter the circulation.** The scheme shown in Fig. 6.4 gives an idea of the site of action and fate of ozone in the skin. However, we knew already that blood is quite resistant to ozone, and body tissues and extracellular fluids have a great reservoir of antioxidant compounds, as well as the ability to regenerate them. **We envisaged that dilution, metabolic breakdown and renal excretion would minimize the increase, if any, of LOPs diluted in the body fluids. Contrary to our expectation, there was a**

significant increase of circulating LOPs which continued long after the session, suggesting a steady inflow from the skin prevailing over catabolism. It would be interesting to follow the kinetics at 1.5–2–3–4 h to localize the peak and the pattern of decrease but, in any case, we have shown that ozone display clear pharmacological effects. PTG values showed a consistent decrease, while (reassuringly) TAS values declined only slightly and temporarily. **The induced oxidative stress had a brief lifetime and did not cause haemolysis or any modification of important blood parameters.** Hepatic enzymes and creatinine plasma levels remained unmodified. Plasma levels of myeloperoxidase, a sensitive marker of the activity of neutrophils (Boxer and Smolen, 1988), did not change. No toxicity after repeated BOEX has been noted for the skin but we use the precaution of protecting moles at risk with a cream rich in vitamin E. **None of our volunteers, nor several patients, have reported acute or late side effects.** For experimental reasons, the author of this book has successively undergone many BOEX, at different times, and each time he has experienced a feeling of great energy and euphoria for the next couple of days. In fact, it would be pleasant to have the time to do it twice weekly! A similar sense of wellness has been claimed by a few patients, who have repeatedly tried this procedure.

Is there an explanation for this good feeling and is it due to ozone or the sauna or both? We can certainly say that a major AHT (rectal insufflation is less effective) also give a sense of well being, but in the case of BOEX the hyperthermia itself may contribute. For a long time, we have wanted to evaluate the hormonal changes related to ozonotherapy and such a study would probably clarify this issue and broaden our vision. We found that **the short-term hormonal changes during and after sauna bathing, particularly the described increase of growth hormone and beta-endorphin, are quite interesting** (Hannuksela and Ellahham, 2001). It is intriguing that long-term sauna bathing helps to lower blood pressure in hypertensive patients in spite of transient activation of the renin-angiotensin-aldosterone system. As expected, these changes are brief and reversible, and the same may occur for ozonotherapy. Whether ozone potentiates the effects of the hyperthermia remains to be seen but both stimuli are likely responsible for triggering a psychoneuroimmunological effect via the release of a cascade of hormones, namely of CRH, ACTH, cortisol, DHEA, growth hormone and so forth. After Payne and Krueger's findings (1992) and Reichlin's postulation (1993), one cannot avoid thinking how deeply ozone therapy can influence the neuroendocrine-immune relationship and how relevant its contribution is to the therapeutic effect.

Fourthly, does ozone switch on a dangerous oxidative stress? Although we noted a remarkable systemic increase of peroxidation, it was transitory, since the levels returned to baseline after 24 h. If the reader has gone through the previous pages, she/he likely realizes that **we purposefully want to induce an acute oxidative stress in patients, using the major AHT** (and perhaps even with rectal insufflation). Probably it can also be realized that **this stress must be adequate** (otherwise it is a placebo), **calculated** (i.e. neither below nor too much above threshold levels) and **transitory**. **This is important because we do not want to override the antioxidant defence system nor cause any toxicity but we want to give a**

precise, atoxic shock to an organism which for various reasons has gone astray. Moreover there is consensus regarding the upregulation of the antioxidant system following repeated but small oxidative shocks.

One study we should do as soon as possible is to evaluate and compare the pharmacokinetics of LOPs (even if they are several and heterogeneous) in single patients during:

- (a) a standard AHT
- (b) a BOEX
- (c) a standard rectal insufflation.

By assessing several parameters and comparing them after each of these procedures, we could gain a fair idea of the magnitude of the biochemical modifications and their therapeutic benefit.

Another important study is to evaluate which of these three procedures is most effective in raising the adaptation to chronic oxidative stress (COS) and, in so doing, yielding clinical improvement.

Fifthly, does BOEX to oxygen-ozone have some advantages? During the treatment, there is a loss of 300–500 g of water due to intense perspiration, normal for sauna bathing. This loss of water is ridiculously advertised as greatly beneficial because the *“body gets rid of oxidised toxins”* in this way! **Transitory hyperoxygenation is also considered relevant, but it would be absurd to increase pO₂ levels through the skin when we could increase them far more simply by breathing humidified oxygen for 1 h.**

The transitory thermal stress associated with the acute oxidative stress is possibly an advantage because it may enhance and accelerate the adaptation to COS. It is well known that **moderate hyperthermia positively modulates the immune system during infection and cancer**. On the other hand, excessive hyperthermia presents several risks (cardiovascular failure, etc.), induces a hypercatabolic state and immune depression; hence it must be avoided. An initial leukocytosis, followed by a modest leucopenia, was observed after exposure to oxygen-ozone in our study and was probably due to a transient release of IL-8. This agrees well with our previous data (Bocci et al., 1998b) showing that IL-8 is a chemokine that is released rapidly by leukocytes in blood that has been briefly exposed to oxygen-ozone. It may be useful in patients with infections, but it is necessary to explore further this finding and look for other cytokines such as Il-2, Il-12, IFN γ and GM-CSF. The simultaneous release of some pro-inflammatory cytokines such as Il-1 may temporarily increase the hyperthermic effect owing to a direct effect on the thermoregulatory centre in the hypothalamus. In spite of our approximate approach, we feel that our studies have some merit because they were the first to evaluate scientifically new ideas which have revived a stagnant field, restricted for three decades to AHT and RI.

What might be the practical usefulness of BOEX and does it have a future? If we listen to commercial advertising, which claims to cure cancer and AIDS, it will have a bright future. Yet we do not believe that the future of ozonotherapy lies in

the claims of charlatans. However, we would like to compare the pros and cons of the current methods. If one uses the standard, optimised AHT method, one is able to slowly treat several ailments without any risk to the patient, but **venous punctures are necessary**.

Rectal insufflation is extremely easy to do (once instructed by the ozonetherapist, the patient can do it at home by himself), very cheap and practically free of risk. Yet it is objected by some patients and, while the delivery of a precise volume of gas is certain, owing to the fecal and luminal content it remains uncertain the ozone dose effectively utilized. However it has the advantage to be used at home and it may be beneficial in certain pathologies.

BOEX has distinct advantages: it is simple to perform, fairly inexpensive, non-invasive (no venous puncture) and does not involve the handling of potentially infectious blood, a point highly appreciated by medical personnel. We have noted some problems: the cabin must be well insulated and BOEX is best performed in a well-organised clinic or in a thermal resort with an entrance room, treatment room, adjacent room to allow a comfortable 1-h rest for the patient and another room with a shower. Whether this approach will truly become useful remains to be established by RCTs, but at this stage it seems to represent a promising tool to modify the biological response in some pathological states:

- The activation of the immune system may be useful in chronic viral diseases (HBV, HCV, herpes I and II, HIV, HPV). It may also be proficient to treat chronic fatigue syndrome (CFS), even though it is probably not a viral disease.
- Metastatic cancer, to avoid palliative chemotherapy, which is usually useless and associated with a negative prognosis. However, it could be even tried as an immunoadjuvant at earlier stages with polychemotherapy. Cancer is a progressive disease and without deceiving the patient it may be possible to improve the quality of life.
- Vasculopathies, particularly hind limb ischaemia due to atherosclerosis, Buerger disease and diabetes. Necrotic ulcers and dystrophic lesions must be simultaneously treated with topical therapy. Patients with severe coronary atherosclerosis, recent myocardial infarction or severe hypertension may undergo BOEX, *but without hyperthermia, starting with a 10-min period and scaling up slowly. Patients with asthma and BPCO must also be treated cautiously*. However it can be added that vasculopathies are positively sensitive to ozonotherapy.
- ARMD, exclusively the atrophic form. Keeping the heating at a low level.
- Scleroderma with Raynaud's phenomenon.
- Moderate burns, to prevent or reduce bacterial infections and enhance healing.
- Some muscular-tendinous lesions in athletes, to reduce muscle contraction and alleviate pain.
- Skin disease, such as infections, psoriasis, perhaps atopic dermatitis and eczema.
- Advanced lipodystrophies, such as Madelung disease. The lipodystrophy occurring during HAART may also be advantageously treated. However there is so no hope to cure HIV-AIDS.

Our provisional protocol envisages a course of 2–3 treatments weekly during the first and second weeks but it must take into account the patient's age, stage and type of disease. We always insist on the “start low, go slow” paradigm to allow for the adaptation to COS. The heating, hence the cabin's temperature should be gradually scaled up from 30°C to no more than 42°C, with periods from 10 min to a maximum of 30 min. Normal subjects interested in using the so-called “ozone steam sauna therapy” as an anti-aging approach may afford to do 5 treatments weekly spending 30–35 min in the cabinet for at least 3 weeks in the Spring and Fall. Obviously an expert ozonetherapist must always be present.

6.6 Extracorporeal Blood Circulation Against Oxygen-Ozone (EBOO)

In both AHT and EBOO, blood is treated *ex vivo* either directly or with the intermediation of a membrane, respectively. The latter procedure resembles a classical dialysis with the substantial difference that the gas mixture: oxygen-ozone flows inside the hollow-fibres and blood flows, in the opposite direction, on the external side of the membrane. This approach has been developed with the enthusiastic collaboration of Prof. Nicola Di Paolo, who has been one of the very few clinicians interested in ozonotherapy. Our investigation started off on the wrong foot in 1991 but, unlike others, who also had the idea to realize a dialysis-like system, we have corrected our idea. Unfortunately, even today, unscrupulous quacks use the dialysis system exploiting cancer and HIV-infected patients with a doubtful and most likely toxic technique in Kenya, India, Mexico and Malaysia. I am glad to report that we (Travagli et al., 2010) have just published a study aimed to compare the efficiency of the ozone transfer of four hydrophilic dialysis filters against the correct hydrophobic gas-exchange device (GED) indispensable for this approach. It has been shown that: (1) dialysis filters present an unreliable range of gas-exchange yield of ozone, often related to variability according to the treatment time; (2) by scanning microscopy, it has been noticed that dialysis fibers are somewhat altered by ozone and (3) because their constitutive materials are not ozone-resistant, they can release toxic compounds harmful for the patient. On the contrary, the appropriate GED (named L001) is ozone-resistant and extremely efficient (84–97%) for transferring ozone to the blood circulating outside the hollow-fibers surface (Bocci et al., 2007).

Our results, detailed elsewhere (Bocci et al., 1999b, 2001b; Bocci and Di Paolo, 2004; Di Paolo et al., 2000, 2002, 2005; Bocci et al., 2008; Travagli et al., 2009a), have clarified that **this apparently obvious method has in fact proved to be a formidable problem** which, only recently, has been **solved by using bio-compatible oxygenators (and NOT dialysis filters)** and continuously **monitoring biochemical results**, which is the only way of optimizing the method. The final system consists of a precise ozone generator, fed by therapeutic oxygen on line, able to deliver a constant flow of the gas mixture for hours. In the past we have

assessed biochemical parameters and toxicity using ozone concentrations from 3 to 80 mcg/ml, but now, with very efficient gas exchangers, we can use ozone concentrations ranging from 0.2 to 1 mcg/ml throughout the session. I never get tired of repeating that ozone is a toxic gas and, when used as a drug, it must be used with great caution and within a defined therapeutic window.

During the last 3 years we tested several types of oxygenators, which are the ozone-resistant “lungs” of the system. This is essential to **prevent leakage of toxic compounds into the blood and this can happen with dialysis filters instead of oxygenators** currently used in cardiovascular surgery. These are made with microporous membranes made up with either polyethylene or polypropylene. They are hydrophobic, permeable only to gases and, unlike dialysis filters, do not form any ultrafiltrate. The exchange of oxygen, ozone and carbon dioxide occurs through the membrane without any bubble formation, thus excluding any risk of gas emboli. The gas exchange is proportional to the membrane surface that ranges from about 0.3 up to 1.6 m². Moreover, it varies according to the blood transit time, hydrostatic pressure, temperature, solubility and partial pressure of the gases on the opposite surfaces of the membrane. In the case of oxygen alone, elevated PvO₂ values are achieved implying full saturation of haemoglobin with a variable volume of oxygen physically dissolved in the plasmatic water. However I must immediately clarify that, by considering that the volume of blood exposed to gas per minute is about 1/60 of the blood volume circulating per minute, **the oxygenation per se has a minimal relevance**. On the other hand, ozone behaves quite differently from oxygen because firstly, it is tenfold more soluble and secondly, owing to its strong oxidant potential ($E^\circ = +2.076 \text{ V}$), it reacts instantaneously with PUFA as well as reducing compounds present in plasma. Thus it is reasonable to assume that ozone reacts immediately at the gas-blood interface.

During cardiovascular surgery lasting several hours, oxygenators remain viable even though several studies have observed some undesirable immunologic modifications, particularly complement activation, a mild leukocyte activation and a decreased platelet count (Edmunds, 1998; Dernek et al., 1999; Stiller et al., 2001). These phenomena, though bothersome, have to be expected as hollow fibers present a foreign surface to blood components. However, when we initiated a preclinical study on sheep using standard oxygenators and heparin according to the standard procedure, we were disappointed to note that, in the presence of oxygen-ozone, the oxygenator decayed rapidly and the blood flow was blocked in about 5–10 min. The oxygenator remained viable using oxygen alone, but as soon as even low ozone concentrations (3–5 mcg/ml) were added, it clogged rapidly and irreversibly. At first it was unclear whether ozone could switch on activation of coagulation factors or platelets. Two critical observations helped to clarify this problem. The first was that substitution of heparin with Na citrate (at full dose to chelate plasmatic Ca²⁺ level) allowed to normalize the extracorporeal circulation of blood in the sheep even using high ozone concentrations (up to 80 mcg/ml). Secondly, and most convincingly, was the observation made by using human platelet rich plasma (prp; Bocci et al., 1999a). On addition of ozone, prp in heparin showed a prompt aggregation while remained normal in citrate so that we could envisage the following sequence of events:

Heparinized prp + Ca²⁺ + O₂-O₃ → adhesion → aggregation →
 → degranulation → release of factors → coagulation

Other data by Iuliano et al. (1997) supported our observation that, in the presence of physiological Ca⁺⁺, ozone activates membrane receptors leading to irreversible damage.

We completed the preclinical study by using citrate and, by examining a number of biochemical parameters, we learnt how blood *ex vivo* behaves in the presence of progressive higher ozone concentrations (Bocci et al., 1999b, 2001b). Total antioxidant status (TAS) and protein thiol groups (PTG) practically halved with an ozone concentration of 35 mcg/ml and the erythrocytic GSH content was also markedly reduced. Blood oxygenation, although remained at supraphysiological values, decreased at the outlet, showing that indeed more ozone is no better. On the whole, the results suggested that we could achieve better results with very low ozone concentrations. The citrate infusion also presented critical drawbacks such as the induction of severe hypocalcemia and acidosis that had to be continuously corrected by a simultaneous reinfusion of Ca⁺⁺ and NaHCO₃.

However, it was reassuring to observe that biochemical parameters normalized quickly at the end of the EBOO and the sheep did not show any acute or chronic signs of toxicity confirming that the capacity of the antioxidant system is able to tame ozone reactivity. In spite of these encouraging results, we understood that the problem of platelet aggregation had to be solved because the use of citrate was unpractical and somewhat risky.

In order to clarify the problem we examined oxygenators perfused with heparinized swine blood *in vitro*. A control exposed to oxygen alone for 60 min showed only a minimal adhesion of platelets on the external surface of the fibers. In contrast, after 5 min exposure to ozone (even at a concentration of 5 mcg/ml), the polypropylene surface was coated with a thick layer mostly composed of platelets. This result indicated that **heparin-coated oxygenators**, which appear biocompatible in usual cardiopulmonary by-pass (Videm et al., 1999), **do not prevent platelet activation in the presence of ozone.**

Thus, initial diffusion of both gases was excellent: the pvO₂ raised up to 500 mmHg and TBARS values increased threefold to sixfold from basal value. However, in a few minutes the pvO₂ fell progressively and peroxidation ceased completely. **After 10 min, pvO₂ levels became irrelevant because even oxygen diffusion was totally impeded. This was due to a coating of platelets, plus fibrin clots and blood cells thick enough to block any gas transfer.** We have postulated that gases are still exiting from the polypropylene micropores but, while oxygen remains trapped, ozone reacts with the adhering platelets leading to total occlusion.

Our work remained at a standstill for a couple of years until we could obtain the most technologically advanced oxygenators, where the external surface has been coated with various compounds. **It is worth noting that heparin-coated oxygenators were unable to prevent platelet activation.** On the other hand the new types of either albumin- or, even better, phosphorylcholine-coated oxygenators are biocompatible and display a better performance not only in cardiovascular surgery,

but have allowed us to perform EBOO satisfactorily in heparinized patients. **The biocompatible layer of phosphorylcholine on the polypropylene surface, in conjunction with the use of very low ozone concentrations, markedly delays platelet adhesion and allows the treatment to be performed in 1 h.**

With the approval of the Ethical Committee of the University of Siena all the perfusions were and are performed in the Dialysis Unit of the University Polyclinic. The final EBOO system is schematically shown in Fig. 6.5

The oxygenator is made with thousands of externally coated polypropylene hollow fibers blocked with polyurethane in a polycarbonate housing. The oxygenation membrane in current use has a surface area of 0.6 m². Extracorporeal circulation is carried out using a last generation apparatus normally used for haemodialysis. Just before perfusion the oxygenator and lines are routinely rinsed with 1 L saline before being connected to the catheters. The veno-venous blood circulation is performed by means of standard arterial-venous fistula needle sets (usually G17), used with great care to maintain the venous access in good condition. One millilitre bolus of 5,000 IU unfractionated Na-heparin diluted with 10 ml saline is injected 5 min before starting the ozonation process and a subsequent slow delivery of a diluted heparin solution has proved unnecessary. The extracorporeal circulation is established by maintaining blood flow at 80–90 ml/min throughout the perfusion. This

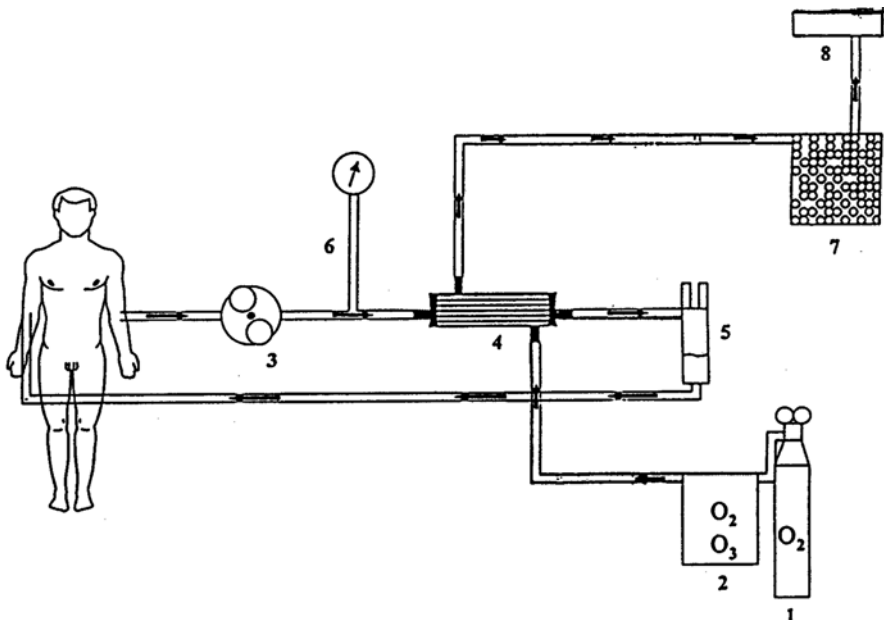

Fig. 6.5 A schematic view of the simplified EBOO apparatus. (1) oxygen supply (2) ozone generator with photometer (3) roller blood pump (4) hollow-fibre oxygenator-ozonizer (5) two air traps with blood filters in series (6) blood pressure monitor (7) silica gel trap (8) ozone destructor

flow appears optimal because a slower one will yield excessive blood oxidation and a higher flow is not well tolerated by the venous access.

Although gas microemboli are not formed, for extreme safety, the line returning the arterial blood to the patient is intercalated with one air trap and a blood filter. Any trace of water vapour, possibly present in the exhaust gas containing CO₂ and the bulk of oxygen-ozone is retained by the silica gel trap before the ozone destructor. At the end of 1-h perfusion, 250 ml of saline are added to the circuit to minimize blood loss. At this stage the oxygenator has a heat exchanger that is not needed and will be eliminated later on thus reducing the priming volume and the cost.

Ozone is produced by a specially devised generator able to deliver gas flows ranging from 25 up to 100 L/h and ozone concentrations between 0.1 and 10.0 mcg/ml. Ozone represents less than 0.2–0.5% of the gas mixture monitored by photometry and visualized in real time. We periodically check the photometry by iodometric titration. All materials used in the system are sterile, ozone-resistant and used only once.

The system in current use is very satisfactory (Bocci et al., 2007; Patent Pending, 2009) and allows to ozonate the whole blood pool in 1 h (Fig. 6.6). The actual

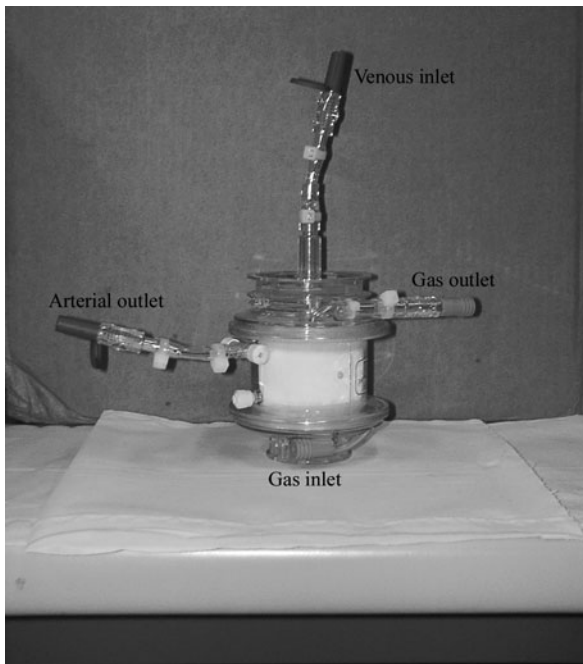

Fig. 6.6 The external aspect of the actual GED named L001. It is made of microporous, ozone-resistant, polypropylene hollow fibers with an external diameter of 200 μm , a thickness of 50 μm and an external membrane surface area of 0.22 m^2 . The phosphorylcholine coating is on the external side in contact with circulating blood while the gas mixture flows inside the fibers in opposite direction. The opposite occurs in dialysis filters

protocol examines the biological and therapeutic effects of twelve EBOO sessions (twice weekly) in chronic limb ischaemia patients against a gold standard (Di Paolo et al., 2005). The very low ozone concentration, while it is unable to overwhelm the potent blood anti-oxidant system, can activate several biochemical pathways. This is interesting because, on one hand, it shows the great capacity of the anti-oxidants to quench oxidation and on the other, that we must deliver an ozone dose above a threshold value to elicit biological activities.

No toxic effects have been noted.

- (a) The extracorporeal circulation of blood against oxygen-ozone is a novelty and has become a reality. The main characteristic is that ozonation levels must be kept at very low levels because one treatment corresponds to about twenty conventional major AHT performed simultaneously.
- (b) Technical and methodological aspects have been resolved satisfactorily and are susceptible to further improvements.
- (c) Owing to the improved efficiency of the oxygenator, up to 5 L of blood/hour can be exposed to very low ozone concentrations, just above the thresholds of the therapeutic window. To enhance ozone tolerance the first and second EBOOs last only 30 and 45 min, respectively.
- (d) As it occurs in the pulmonary circulation, the efficiency of the hollow fibers allows gas exchange in 1 min. Needless to say that only a minor proportion of the two gases act on the flowing blood while the exceeding gas mixture goes to the destructor.
- (e) Both oxygenation and ozonation remain effective without any increase of venous pressure.
- (f) In arteriopathic patients (grade III and IV) subjective and objective clinical improvements have often been noted after the first treatment. Twenty-eight patients were randomized to receive either EBOO or intravenous *Endoprost* (a prostacyclin analogue), in a controlled clinical trial. Patients treated with EBOO showed a highly significant regression of skin lesions while the orthodox treatments do not provide such a rapid improvement (Di Paolo et al., 2005). In fact this approach has been specifically developed for the treatment of critical patients.
- (g) Neither metabolic derangement, nor changes in blood chemistry, nor any toxic effect has been observed during or months after the cycle.
- (h) It is necessary to prove objectively the clinical data and support them with laboratory data evaluating: (1) adaptation to chronic oxidative stress, by measuring levels of antioxidant enzymes, (2) various oxidative stress proteins, particularly heat stress protein (HSP32) or haeme-oxygenase (HO-1), (3) 2,3-diphosphoglycerate (2,3-DPG) values, (4) hormonal levels able to explain the feeling of wellness and disappearance of pain, (5) any modification of low and high density lipoproteins, cholesterol and fibrinogen levels, and (6) the immune status. It appears interesting to evaluate if one of the mechanisms switched on by ozonotherapy involves the release and activation of autoctonous staminal cells. If it does, it will represent a functional as well as an anatomical therapy. This

could represent one of the most important effects and we will try to visualize a possible neoangiogenesis in the ischemic areas.

Some possible disadvantages must be taken into due consideration: (1) the cost of the disposable oxygenator, including ancillary materials is now near 450 € but it could decrease once the application will be used world-wide. (2) The cost of a qualified technician, expert in dialysis technique. (3) The potential deterioration of venous access. (4) The occasional need of inserting a catheter into a central vein to continue the cycle, with the related risk of infection (this recently occurred in two patients, who had to stop the treatment). The last problem may be reduced by using improved catheters impregnated with antibacterial substances (Wenzel and Edmond, 1999).

At this stage, we feel compelled to vigorously ascertain the therapeutic benefits of EBOO in the following areas:

- (a) *Critical, inoperable ischemic limbs (stage III and IV, Leriche-Fontaine) when amputation remains the only option.* Medical treatments (iloprost infusion, pentoxifylline, electrical spinal-cord stimulation, anticoagulants, platelet anti-aggregation, anti-atherosclerotic drugs, etc.) help but are rarely successful (Bergqvist, 1999). The surgical procedure of distal venous arterialisation appears promising (Taylor et al., 1999) but it is also a complex and experimental procedure. However, a comparison of these approaches appears useful for further progress;
- (b) *End-stage ischemic cardiomyopathies, previously operated on with no success.* This problem will be discussed further later on in relation to the failure of the *Celacade* system to improve preterminal chronic heart disease' s patients.
- (c) *Acute cerebral ischaemia*, to be treated with EBOO as soon as possible to reoxygenate the hypoischaemic (penumbra) and infarctuated areas, thus limiting neuronal death and favoring a more rapid recovery. Neurologists can use the thrombolytic approach only on about 20% of patients reaching the hospital within 3–4 h after the ischemia. The remaining 80% of patients can be treated only with antihypertensive drugs, platelet-antiaggregants and antibiotics. It is now hoped to perform a pilot study by using major AHT in the latter patients.
- (d) *Chronic HCV hepatitis in patients who are IFN-resistant or IFN-intolerant or because they refuse orthodox therapy;*
- (e) *Chronic renal failure, which is always accompanied by immunosuppression and a chronic oxidative stress* (Witko-Sarsat et al., 1998; Morena et al., 2000) continuously aggravates the metabolic disorder (Bocci, 2002). In such a case, the oxygenator may be situated parallel to the dialysis filter and used following the dialysis session after a bolus infusion of antioxidants to reconstitute a sufficient antioxidant capacity depleted during dialysis (Section 9.9).

In other diseases such as:

- (f) Metastatic, chemoresistant cancer and severe primary or secondary (to HIV-protease inhibitors treatment) lypodistrophies, the usefulness of EBOO remains to be considered against the validity and cost-benefit of this approach.

6.7 Conclusions

Today ozonotherapy can be performed using six different modalities. Besides the old but still quite valid methods of major and minor autohaemotherapy and rectal insufflation, we have developed and evaluated other options such as the quasi-total body exposure to oxygen-ozone and the EBOO. In patients with precarious venous access, as a blood substitute, we are now using the glucose or saline-peroxide solution, which represents a form of biooxidative therapy with a clear rationale and the advantage of being inexpensive and potentially useful to millions of people without medical assistance. If patients are diabetics, it is possible to use the saline-peroxide solution as soon as it is ready.

Although all of these procedures must be controlled and supervised by physicians expert in ozonotherapy, rectal insufflation is amenable to be performed at home by the patient with physician's advice. Ozone must never be breathed but, if the dose is adapted to the potent antioxidant capacity of body fluids, the above described methods offer flexible and remarkable therapeutic advantages. Finally, when it was needed, I have successfully combined major and minor AHTs, RI, BOEX as well the gluco-peroxide infusion.

The central aim of ozonotherapy is to give a precise, atoxic shock to an organism which for various reasons has gone astray; the hope is that repeated, timely shocks will readjust several biological functions by means of many messengers (ROS, LOPs and autacoids generated by ozone) delivered by circulating blood to the whole body. We have coined the term "therapeutic shock" to symbolize the possibility of reactivating the natural positive capabilities to restore health or, in better words, to stimulate the "vis medicatrix naturae".

I believe that the simultaneous induction of an acute and precisely calculated oxidative stress on different areas such as blood, the skin and the gut mucosal system can result in a more comprehensive and perhaps synergistic response of the body defense system. Indeed chronic diseases must be attacked from different angles and we have evidence that the stimulation of several biochemical pathways in different organs can be therapeutically beneficial.