

Microclimate environment model construction and control strategy of enclosed laying brooder house

Liai Gao ^{*,†,‡,1} Mengwei Er,^{*,1} Lihua Li ^{*,†,‡,1} Peng Wen ^{*,†,‡}
Yuchen Jia ^{†,‡,§} and Limin Huo ^{*,†,‡,2}

^{*}College of Mechanical and Electrical Engineering, Hebei Agricultural University, Baoding 071000, China; [†]Key Laboratory of Meat and Layer Breeding Facilities Engineering, Ministry of Agriculture and Rural Affairs, Baoding 071000, China; [‡]Hebei Provincial Key Laboratory of Livestock and Poultry Breeding Intelligent Equipment and New Energy Utilization, Baoding 071000, China; and [§]College of Information Science and Technology, Hebei Agricultural University, Baoding 071000, China

ABSTRACT The growth performance and health of chicks can be significantly improved by a suitable microclimate in brooder houses. However, the microclimate of the chicken house is affected by factors such as its structure and the heat dissipation of chickens, making it is difficult to establish an accurate mathematical model and achieve effective regulation. In this paper, the environmental data acquisition system of enclosed chick brooder house was established by analyzing various environmental factors in brooder houses. According to the structural characteristics of brooder houses and the growth environment of chicks and other parameters, the microclimate simulation model of brooder houses was established using the physical law of energy balance. The coefficient of determination R^2 (R-square) between simulated temperature and humidity output value and measured value was 0.7634 and 0.9740, respectively, and Root Mean Square Error (RMSE) was 1.55°C and 2.61%, respectively. The correctness of the simulation model was verified. On the basis of established

microclimate models, a simulation model of fuzzy decoupling Proportion Integration Differentiation (PID) control in chicken house environments was established for the strong coupling between temperature control and general risk control system in chicken houses. Different control strategies were generated by fuzzy and logical reasoning about multiple environmental factors. The compensation coefficient was added to optimize the environmental regulation system of brooder houses. The temperature maximum deviation between the set value and the fuzzy decoupling PID controller was 0.5°C, the maximum relative error was 2.7%, the maximum deviation of relative humidity between the set value and the fuzzy decoupling PID controller was 4.93%, the maximum relative error was 10.49%. The simulation results show the control strategy meets the temperature and humidity control requirements, verify the effectiveness of the control strategy and model. The experimental results can guide the actual environmental control of brooder houses.

Key words: enclosed chick brooder house, microclimate environment model, fuzzy decoupling control strategy, energy and mass balance, simulation

2022 Poultry Science 101:101843
<https://doi.org/10.1016/j.psj.2022.101843>

INTRODUCTION

The laying performance of laying hens can be traced back to the management during the brooding period, and the environmental regulation of brooder houses is the most critical link in the management during the

brooding period (Hassan et al., 2018). Chickens are poorly adapted to the environment, so the environmental parameters of brooder houses should be strictly controlled. Temperature is the most important factor affecting the growth of chicks, and high or low temperature is not conducive to the health of chicks (Kim et al., 2021). Similarly, proper humidity also contributes to the healthy growth of chicks (Yao, 2020). Light not only affects the feeding and drinking of chickens but also affects their sexual maturity. Reasonable light time and intensity are beneficial to the growth of chickens. The excessive concentration of harmful gases in chicken houses can easily cause respiratory diseases in chickens, and ventilation can significantly reduce the

© 2022 The Authors. Published by Elsevier Inc. on behalf of Poultry Science Association Inc. This is an open access article under the CC BY-NC-ND license (<http://creativecommons.org/licenses/by-nc-nd/4.0/>).

Received December 17, 2021.

Accepted February 28, 2022.

¹These three authors contributed equally to this work and should be considered co-first authors.

²Corresponding author: liminhuo@163.com

concentration of harmful gases (Lin, 2017). In order to ensure the laying performance of laying hens, the growth environment of chickens should be strictly and effectively regulated during brooding.

The microclimate environment of an enclosed brooder house is an independent system. Environmental factors such as temperature, humidity, the concentration of harmful gases, and the light intensity of chicken houses affect the health of chicks. Therefore, it is necessary to establish a microclimate environment model to simulate the actual environment in the chicken house Cheng et al. (2019). modeled the airflow and temperature of the chicken house by Computational Fluid Dynamics (CFD) and obtained the influence of different fan positions on the environment of chicken houses Wang et al. (2018). discussed the effects of roof insulation on thermal environment of poultry houses and egg production rate in hot weather, the above study is to control the environment of adult chicken houses. The weight of the adult chickens is fixed, and the daily heat exchange with the chicken house environments is fixed. But for the chicks, the weight of chicks varies from day to day and becomes more obvious after a week of age. Therefore, the heat exchange between chicks and the air in the house is variable.

Microclimate model can reflect the environmental information of each point in the chicken house, such as temperature, humidity and so on. Breeders can clearly understand the living environment of chickens. When the temperature in the room is low, you need to turn off the fan for insulation, and the humidity will gradually increase. Therefore, temperature control will also cause humidity changes, so there is a strong coupling between temperature and humidity Ulpiani et al. (2016). designed three different logic switches to regulate building heating systems for the environment of livestock and poultry houses. After comparing the comfort performance and energy consumption of the three control systems, the fuzzy controller is superior to the other 2 controllers Manonmani et al. (2018). adopted neural networks to model and control the greenhouse system Groener et al. (2015). designed the low-cost greenhouse environmental control system, it can better control the temperature and humidity of the greenhouse Azaza et al. (2015). compared fuzzy controller and switch controller for the indoor environment of chicken houses in winter. The results show that the fuzzy controller can respond well to temperature and humidity, which realizes the control of the environmental parameters of chicken houses in winter Xie et al. (2017). studied the design and regulation strategy of multiple environmental factors regulation systems for enclosed piggery. The system can provide a comfortable environment for the growth of pigs, offering a reliable research idea for further environmental regulation of livestock and poultry Oliveira et al. (2020). summarized the progress of greenhouse environmental control and proposed the existing problems and development trends of greenhouse environmental control Li et al. (2020a). published the research progress on key technologies and facilities for

environmental control of large-scale chicken farming in China. They also proposed the mode of intelligent breeding and welfare breeding. Meaningful guiding information was put forward for environmental regulation of large-scale chicken farming. The above studies provide a reference for the environmental regulation model of brooder houses. However, the environmental requirements of chicks are demanding. If the experimental control is not ideal, the health of chicks may be affected. Therefore, the microclimate environment model of chick houses should be strengthened, and the control theory should be closely combined with actual production to provide a theoretical basis for actual control strategies.

This paper established an enclosed environment data acquisition system for laying hen's brooder house with Baoding Yonghe chicken farm (brooder farm) as the research object. According to the structural characteristics and environmental conditions of the brooder house, the microclimate environment model of the brooder house at different ages was established. The heat exchange model of the chick brooder house was established by analyzing the environmental heat exchange factors of the chicken house. The factors of humidity exchange in the chicken house were analyzed, and the humidity exchange model of the chick brooder house was established. For the chick brooder house, the field regulation experiment had too much impact on the chick breeding environment. In order to effectively control the temperature and humidity in the chick brooder house, the decoupling compensation coefficient was obtained by field test based on the established microclimate environment control mode, the fuzzy decoupling Proportion Integration Differentiation (PID) control strategy and model of temperature and humidity environment factor of the chick house were studied. Simulation analysis verified the correctness of the microclimate environment model and the effectiveness of the proposed control strategy.

MATERIALS AND METHODS

Animal and Experimental Site

The experimental site selected in this paper is located in Yonghe Chicken Breeding Base, Baoding, China. The house is the No. 8 chick brooder house with 30,000 Hailan brown chickens. The chicken house is 63 m long, 11.5 m wide, 3.2 m high and 4 m ridge height. The door of the chicken house faces west, and the fan is on the east wall. There are 12 windows of 1 m × 1 m on the north and south walls each, 1.5 m above the ground and 3.6 m apart from each other. The heating equipment is distributed between the windows on the south side to heat the chicken house.

The ground of the chicken house is made of cement, and the surrounding walls are made of bricks with cement mortar coated on the outer surface. The chicken house roof is made of 0.1-m thick color steel plates with thermal insulation foam, and 10 vents of 0.5 m × 0.5 m are evenly distributed longitudinally on the roof. There are 3 rows of 4 layers in the chicken house, the south and

north aisles of the chicken house are 0.9 m wide, and the middle 2 aisles are 1.2 m wide. There is a cesspit with a width of 2.1 m and a depth of 0.3 m below each row. The structure diagram of the chick brooder house is shown in Figure 1.

Experimental Design and Measurement Instruments

The chicken house has 11 radiators in series with a length of 0.6 m, a width of 0.6 m, and a thickness of 0.05 m. A fan with a speed of 1,370 r/min was placed behind each radiator, the fan type is YSWF68M4-400N-330 (Guangzhou Suwei Electronic Technology Co. Ltd, China). On the east side of the chicken house, there were four large fans with a diameter of 1.3 m and one small fan with a diameter of 1 m. The four large fans on the east wall of the chicken house were named as No.1–No.4 fans from south to north, respectively.

The Aicevoos anemometer AS-H (Wuhan Zhongce Hongtu measurement instrument co. Ltd, China) was used for wind speed measurement. The wind speed measurement range was 0.3 to 30 m/s, the wind speed error was 5% RDG 0.1, and the resolution was 0.1 m/s. This anemometer was used to measure the wind speeds in the chicken house and the large fans on the east side.

The non-contact infrared thermometer SWVEY590s (Guangzhou Suwei Electronic Technology Co. Ltd) was used to measure the temperature of the wall and ground with a measuring range of -50 to 590 °C and a precision error of 2%. The distance ratio of the measured object was 12:1, and the emissivity was adjustable from 0.10 to 1.00. The temperature of the roof, floor, and wall inside the chicken house and that of the roof and wall outside the chicken house were measured with this equipment.

The temperature and humidity sensor Zl-th10TP (Beijing CIMC Technology Co. Ltd, China) imported from Switzerland was used to measure the temperature and humidity in the chicken house, with a temperature

accuracy of 0.5 °C and a humidity accuracy of 3%, equipped with a General packet radio service (GPRS) base station positioning system. This equipment was used to collect the temperature and humidity of the air in the chicken house. The transverse section of the brooder house and sensor position diagram was shown in Figure 2.

Analysis of Microclimate Environment in the Brooder House

Environmental Heat Exchange Model The environment of the chicken house is mainly affected by the heat dissipation of chickens, the air in the house, heaters, fans, windows, humidification equipment, enclosure structure (cement brick-concrete), roof (foam color steel plate), and ground (cement) Zhu et al., 2014; Ni et al., 2017; Xie et al., 2019; Andretta et al., 2021). The dynamic heat exchange model formula in the chicken house is shown in ((1).

$$\Delta Q = Q_{chick} + Q_{solar} + Q_{heat} + Q_{ground} + Q_{wal} + Q_{ven} \quad (1)$$

Where the parameter ΔQ is the change of internal heat quantity of the chicken house; the parameter Q_{chick} is the heat exchange of the chicken body surface; the parameter Q_{solar} is the total solar radiation heat of the chicken house; the parameter Q_{heat} is the heat supply quantity of the chicken house heating system; the parameter Q_{ground} is the heat dissipation of chicken house floors; the parameter Q_{wall} is the heat dissipation from the inner wall of the chicken house; the parameter Q_{ven} is the heat loss of ventilation outlets.

$$Q_{chick} = N \cdot S_{chick} \cdot [\varepsilon \cdot \delta (T_{chick}^4 - T_{house_in}^4) + H_{air_chick} (T_{chick} - T_{house_in})] \quad (2)$$

The chicks exchange heat with the air in the house by daily activities. The heat dissipation of chicks has a great relationship with their own weight. The difference between chicks and adults is the weight of chicks varies from day to day and becomes more obvious after a week of age. The heat exchange model formula between the chicken body surface and the air chick house is shown in (2).

$$Q_{solar} = \rho_{sun} \cdot S_{wall} \cdot I_{solar} \quad (3)$$

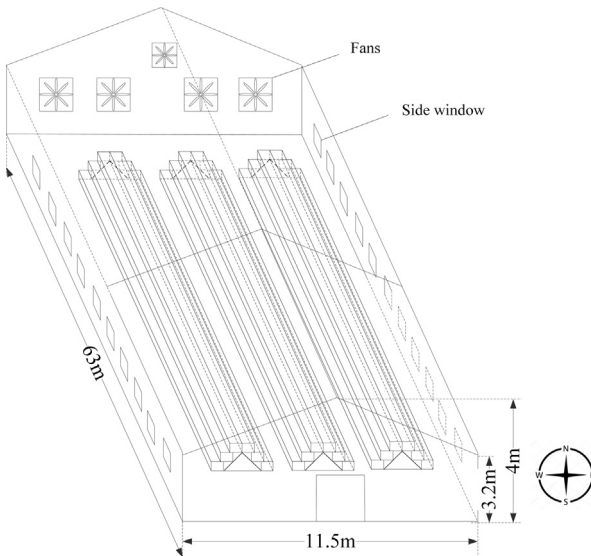

Figure 1. Schematic diagram of the chicken house structure.

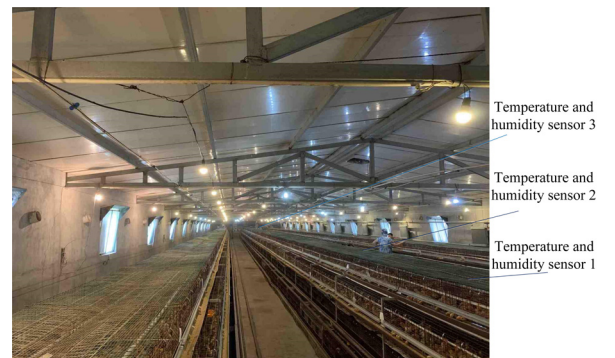

Figure 2. The transverse section and sensor position diagram.

For the enclosed brooder house, the heat from solar radiation is related to the solar radiation intensity and the surface area of the chicken house structure in the summer. The solar radiation heat formula is shown in (3).

$$Q_{heat} = C_{water} \cdot TRA_{water} \cdot (T_{water_out} - T_{water_in}) \quad (4)$$

The heating boiler exchanges heat through the difference between the heat emitted and the temperature of the chicken house. The heat generated per unit time is shown in (4).

$$Q_{ground} = S_{ground} \cdot K_{air_ground} \cdot (T_{house_in} - T_{air_ground}) \quad (5)$$

In general, the air temperature in the chicken house is higher than the floors temperature, so the floors exchange heat with the air in the chicken house. The heat dissipation of chicken house floors is shown in (5).

$$Q_{wall} = K_{wall} \cdot (T_{wall_in} - T_{wall_out}) \cdot S_{wall} \quad (6)$$

The effect of chicken house enclosure structure is mainly related to material, area, and temperature difference inside and outside. The heat dissipation from the inner wall of the chicken house is shown in (6).

$$Q_{ven} = \rho_{air_in} \cdot L \cdot C_{air_in} \cdot (T_{house_in} - T_{air_out}) \quad (7)$$

In order to maintain the air quality in the chicken house, the fan is often turned on for ventilation. Ventilation takes away a certain amount of heat, and the heat loss is related to the ventilation volume of the fan. The heat loss of ventilation outlets is shown in (7).

With the above formulas, the heat balance model of the brooder house can be established. In this paper, the generation and emission of all the heat in the chicken house are calculated by taking the average value per hour to simulate the value of the environmental parameters of the chicken house.

Environmental Humidity Balance Model In the air environment of chicken houses, humidity content is a crucial environmental component. In chicken houses, the surface and breath of chickens can bring water vapor exchange. In addition, a certain amount of water vapor is emitted from the drinking water device, humidifying and spraying device, and the ground of the chicken house [Ma and Miao, 2005](#); [Manonmani et al., 2018](#); [Quan, 2019](#)). According to the law of conservation of mass, the dynamic equilibrium formula of humidity in the chicken house can be obtained, as shown in ((8).

$$\begin{aligned} L_{fan} \cdot \rho_{air_in} \cdot d_{in} \\ = V_{house} \cdot L_{fan} \cdot d_{out} + h_{chick} + h_{surface} + h_{equip} \end{aligned} \quad (8)$$

Where the parameter L_{fan} is the chicken house ventilation; the parameter d_{in} is the moisture content of the air in the chicken house; the parameter d_{out} is the moisture content of the air outside the chicken house; the parameter h_{chick} is the amount of water vapor emitted by chickens; the parameter h_{equip} is the amount of water vapor generated by wet curtain equipment; the parameter

$h_{surface}$ is the amount of water vapor emitted from the surface of the chicken house, which can be ignored.

$$\varphi = \frac{\rho_1}{\rho_2} \times 100\% \quad (9)$$

$$\begin{aligned} \rho = 30^{-9} T^4 + 10^{-6} T^3 + 10^{-5} T^2 + 0.0003 T \\ + 0.0048 \end{aligned} \quad (10)$$

$$d = \frac{622 \times \varphi \times p_s}{p_0 - \varphi \times p_s} \quad (11)$$

$$\begin{aligned} p_s = 10^{-7} T_{house_in}^5 - 20^{-5} T_{house_in}^4 + 0.0019 T_{house_in}^3 \\ - 0.0674 T_{house_in}^2 + 1.3046 T_{house_in} - 8.4682 \end{aligned} \quad (12)$$

Where ρ_1 and ρ_2 represent the density of water vapor contained in the air inside the chicken house and the saturated water vapor density at the same temperature, respectively, as shown in (9). ρ is the water vapor density, which is related to temperature, as shown in (10). d is the moisture content. p_0 is the standard atmospheric pressure, and p_s is the saturation pressure of water vapor, as shown in (11) and (12).

Chickens produce water vapor mainly by breathing in the brood house. The water vapor produced by chicks is estimated in terms of heat emitted by chicks, as shown in Formula (13).

$$h_{chick} = \frac{Q_{chick}}{2450000} \quad (13)$$

Microclimate Environment Simulation Model in the Brooder House

The chicken house microclimate environment model is a complex system with multiple inputs, which needs to consider the influence of various environmental factors. According to the mechanism of microclimate environment change, heat exchange model and humidity balance model of microclimate environment were established respectively.

In the microclimate environment heat exchange model, the input values are the fan wind speed, the air temperature in the chicken house, the weight of the chicken, the aisle temperature of the chicken house, the wall temperature and the ambient temperature outside the chicken house, etc. The most important factor is the weight of chickens. The most important factor is chicken weight, which increases with age. In order to simplify the model, the chicken weight module is input according to the weight of chickens' age, as shown in [Figure 3](#).

In the humidity microclimate environment balance model, the input values are respectively the humidity emitted by chickens, the humidity inside the chicken house, the humidity outside the chicken house, the humidity taken away by ventilation, and the humidity generated by humidification equipment. Among them,

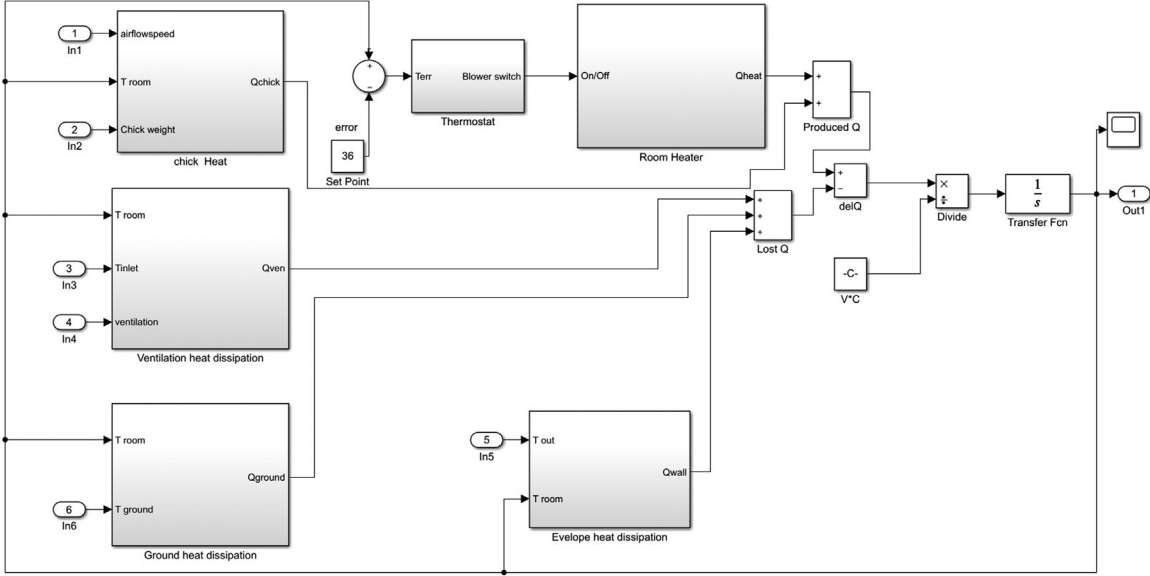

Figure 3. The microclimate environment heat exchange model.

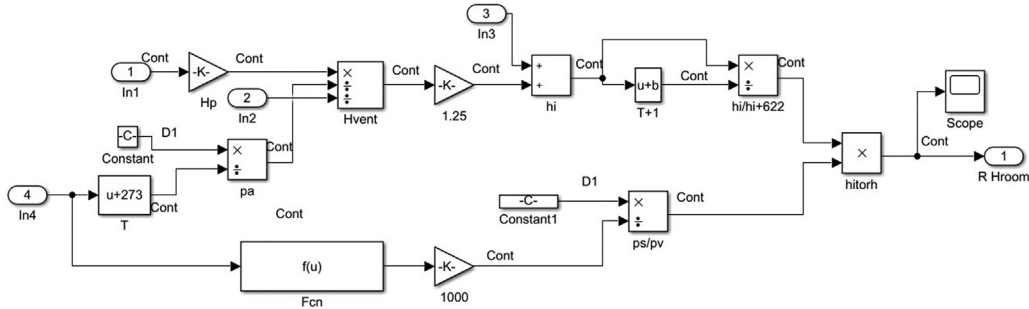

Figure 4. The microclimate humidity balance model.

the humidity emitted by chickens is related to its own heat production. The humidity unit in the model is unified as relative humidity by the conversion of moisture content and relative humidity, as shown in Figure 4.

Control Model and Strategy of the Chick Brooder House

Fuzzy PID Controller The fuzzy controller is a controller based on rules, which adopts the experience of field operators or the knowledge of experts and does not need an accurate mathematical model when designing the controlled object. Thus, it is simple in design and easy to use (Ai et al., 2013; Zhang, 2018). The basic structure of the fuzzy controller is shown in Figure 5.

According to the rules of the fuzzy PID control algorithm, error E and error change rate Ec are taken as the inputs of the fuzzy PID controller, and ΔKP , ΔKI , and ΔKD are taken as the outputs of the fuzzy PID controller. According to the experience of field engineers and the theory of experts, the fuzzy subsets of inputs E and Ec and outputs ΔKP , ΔKI , and ΔKD are divided into 7 grades: "positive big (PB), positive middle (PM), positive small (PS), zero (ZO), negative small (NS), negative medium (NM), and negative large (NB)". The universe of

temperature error E and error change rate Ec is $[-2, 2]$, and the quantified grades are $\{-2, -1.5, -0.5, 0, 0.5, 1, 1.5, 2\}$. The universe of humidity error E and error change rate Ec is $[-10, 10]$, and the quantified level is $\{-10, -8, -6, -4, -2, 0, 2, 4, 6, 8, 10\}$.

Fuzzy Control Strategy and Rules According to a large amount of practical control experience, the state and trend of the system are determined based on the quantification of inputs and outputs. According to different combinations of error E and error change rate Ec , 49 strategy and rules of ΔKP , ΔKI , and ΔKD in fuzzy PID control system are established, as shown in Table 1 (Xu et al., 2007; Li et al., 2020b; Su et al., 2020).

Fuzzy Decoupling PID Control Model In this paper, the fuzzy decoupling PID controller of microclimate environment in the chick brooder house is divided into a

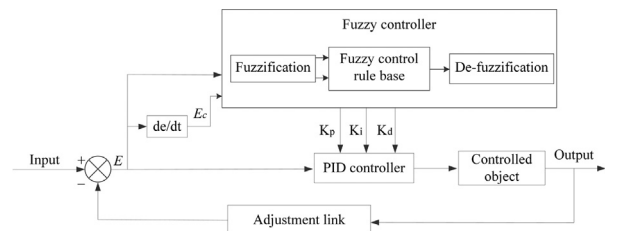
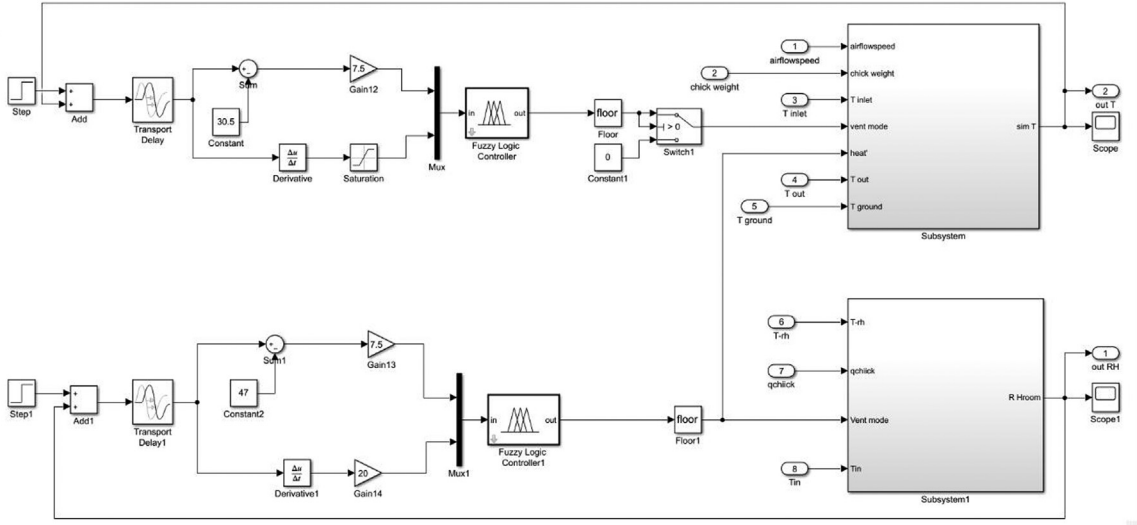

Figure 5. The basic structure of the fuzzy PID controller.

Table 1. $\Delta K_P/\Delta K_I/\Delta K_D$ fuzzy control rules.

| Fuzzy universe (E) | Linguistic variable universe (E_c) | | | | | | |
|------------------------|--|----------|----------|----------|----------|----------|----------|
| | NB | NM | NS | ZO | PS | PM | PB |
| NB | PB/NB/PS | PB/NB/NS | PM/NM/NB | PM/NM/NB | PS/NS/NB | ZO/ZO/NM | ZO/ZO/PS |
| NM | PB/NB/PS | PB/NB/NS | PM/NM/NB | PS/NS/NM | PS/NS/NM | ZO/ZO/NS | NS/ZO/ZO |
| NS | PM/NB/ZO | PM/NM/NS | PM/NS/NM | PS/NS/NM | PM/NS/NS | NS/PS/NS | NS/PS/ZO |
| ZO | PM/NM/ZO | PM/NM/NS | PS/NS/NS | PS/ZO/NS | NS/PS/NS | NM/PM/NS | NM/PM/ZO |
| PS | PS/NM/ZO | PS/NS/ZO | ZO/ZO/ZO | NS/PS/ZO | NS/PS/ZO | NM/PM/ZO | NM/PB/ZO |
| PM | PS/ZO/PB | ZO/ZO/NS | NS/PS/PS | NM/PS/PS | NM/PM/PS | NM/PB/PS | NB/PB/PB |
| PB | ZO/ZO/PB | ZO/ZO/PM | NM/PS/PM | NM/PM/PM | NM/PM/PS | NB/PB/PS | NB/PB/PB |

**Figure 6.** The decoupling controller.

temperature fuzzy controller and a humidity fuzzy controller (Yin et al., 2015). The temperature deviation and deviation change rate are taken as inputs, and the fan opening mode and heater are used to control the temperature. The humidity deviation and deviation change rate are taken as input, and the relative humidity is controlled by the fan on mode. The relationship between fan opening mode and the temperature compensation coefficient η is determined by experiments. Thus the decoupling between temperature and humidity is realized. The structure of the decoupling controller for microclimate environment in the chick brooder house is shown in Figure 6.

There are different temperature compensation coefficients η in different ventilation modes, and the heating capacity of the heater is determined by η , which decouples the ventilation control and temperature control of the fan. According to the wind speed of the fan, the ventilation volume and the heat taken away by ventilation are calculated (Li et al., 2017). The corresponding wind speeds for different ventilation modes are shown in Table 2.

In order to reduce humidity, the fan is turned on, and the temperature of the chick brooder house is also decreased. In order to keep the temperature of the chick brooder house in an appropriate range, the heating equipment needs to be turned on to compensate for the temperature. The relationship between the starting mode of

the fan and the temperature change in the chicken house is analyzed by turning on the fan in mode 1, mode 2, mode 3, and mode 4 for ventilation and dehumidification. The temperature curves in the brooder house under different ventilation modes are shown in Figure 7.

From Figure 7, it can be seen that the temperature of the chicken coop in different ventilation modes shows a downward trend, among which the lowest temperature drop caused by ventilation mode 1 is 0.3°C , and the highest temperature drop caused by ventilation mode 4 is 2.5°C , thus it can be concluded that different ventilation modes have significant influence on the temperature in the chicken houses. In order to better analyze the influence of ventilation mode on the temperature in the chicken houses.

Through the energy balance formula (14), the compensation coefficient η between different ventilation modes and temperature is calculated, and the heat taken

Table 2. Window wind speed in different ventilation modes.

| Mode | Average wind at the south window (m/s) | Average wind in the north window (m/s) |
|------|--|--|
| 1 | 0.2 | 0.2 |
| 2 | 1.7 | 1.9 |
| 3 | 2.6 | 2.7 |
| 4 | 3.1 | 3.2 |

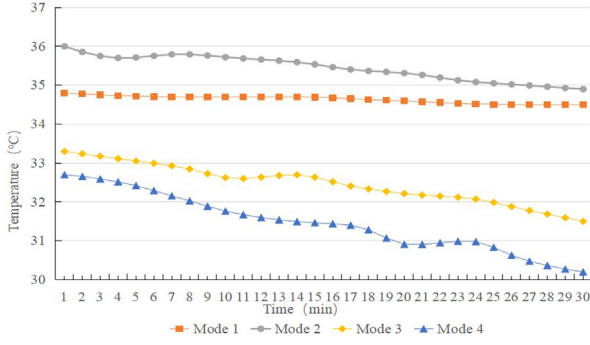

Figure 7. Temperature curves in different modes.

Table 3. Compensation coefficient η under different ventilation modes.

| Ventilation mode | Heat loss due to ventilation (w) | Temperature change value (°C) | Compensation coefficient (h) |
|------------------|----------------------------------|-------------------------------|------------------------------|
| 1 | 228.9 | 0.3 | 0.2 |
| 2 | 839.3 | 1.1 | 0.55 |
| 3 | 1,373.4 | 1.8 | 0.9 |
| 4 | 1,907.5 | 2.5 | 1.25 |

away by ventilation is compensated by the heater, the compensation coefficient η under different ventilation modes is shown in Table 3.

$$\Delta Q_{ventilate} = \Delta Q_{heat} \tag{14}$$

RESULTS

Simulation Results of the Microclimate Environment Model

The actual measured values were sorted into Excel data format in hours and then imported into the Simulation input module to obtain the output temperature and humidity data. Through the analysis of measured data and simulation data, the accuracy of the chicken house microclimate environment model was analyzed (Van et al., 2003).

The environmental data of the chicken house are non-linear. The absolute error and relative error of the measured temperature and simulated output data are analyzed. The average temperature and humidity data collected hourly from August 18 to September 14, 2020, are compared, as shown in Figures 8 and 9, respectively.

The error between simulated value and real value is an important index to judge the accuracy of the microclimate environment model. The error values of the measured and simulated temperature and humidity data are shown in the figures below, and the fluctuation degree of error values can be seen. The relative error value is an index to judge the deviation degree between simulated value and real value. The errors and relative errors of measured and simulated temperature and humidity data are shown in Figure 10.

Simulation of Fuzzy Decoupling Control Model and Strategy

Experimental data are environmental parameters of the No. 8 brooder house in Yonghe Chick Breeding Base, Baoding, China, on September 5, 2020. The fuzzy decoupling control model of the microclimate environment was used to simulate and analyze the temperature and relative humidity in the brooder house. The temperature in the brooder house was set at 30.5°C, and the relative humidity was set at 47% Figure 11. shows the results of the manual control system Figure 12. presents the simulation results of the fuzzy decoupling PID control system.

DISCUSSION

Analysis of the Simulation Results of the Microclimate Environment Model

In this model, it is assumed that the microclimate environment of the chicken house is uniform, but the ventilation is not uniform due to the different positions of the actual fans. When the fan on the south side is turned on, the wind speed in the north aisle is lower than that in the south aisle. When the fan on the north side is turned on, the wind speed in the south aisle is lower than that in the north aisle. This phenomenon will lead to uneven wind speed in the chicken house, resulting in uneven temperature and humidity in the actual chicken house.

According to Figure 8, the variation trend of the simulated temperature and measured temperature is consistent. The determination coefficient R^2 between simulated and measured temperature values is 0.7634. The root

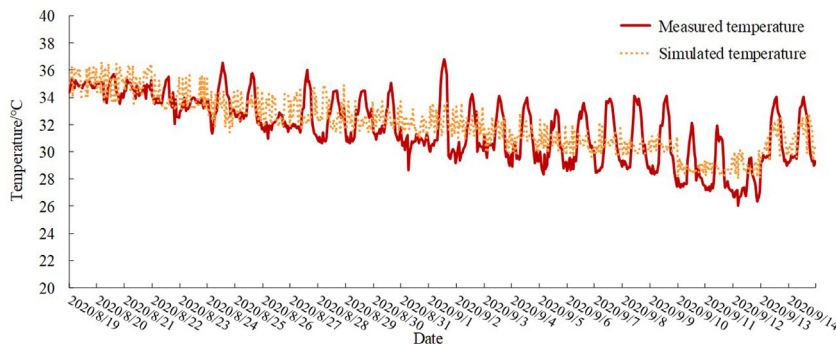

Figure 8. Temperature comparison.

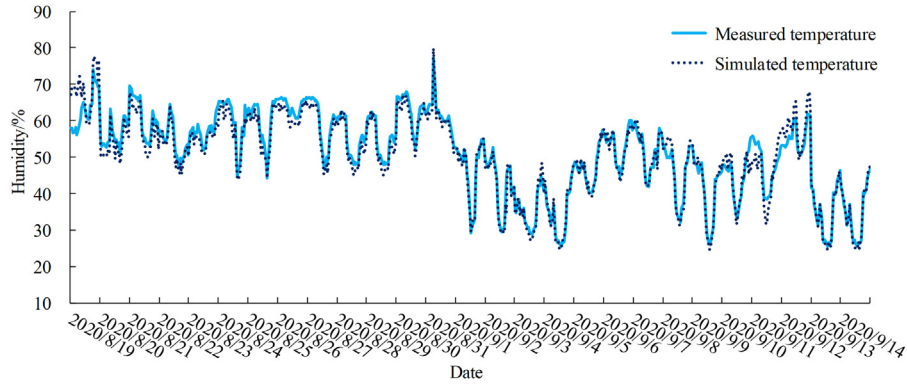

Figure 9. Humidity comparison.

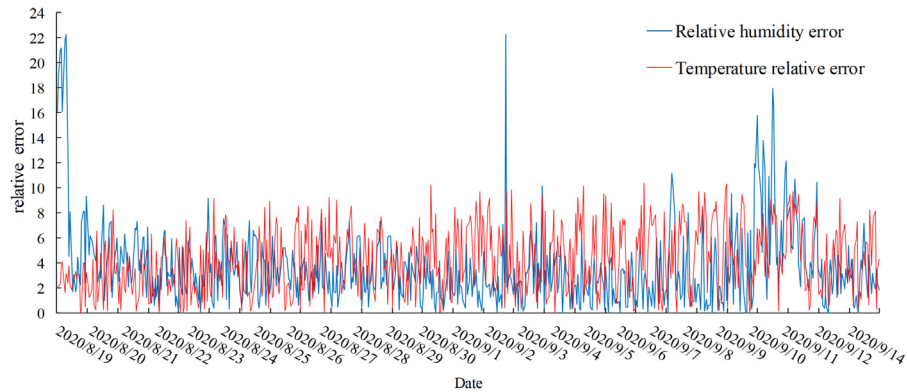

Figure 10. The error between measured and simulated data.

mean square error is 1.55°C , the maximum temperature error is 3°C , and the average temperature error is 1.32°C . The average relative error is 4.2%, and the maximum relative error is 10.39%. It can be concluded that the simulated temperature value can accurately reflect the temperature of the brooder house at different ages. As shown in Figure 9, the variation trend of simulated and measured relative humidity values is relatively consistent. The coefficient of determination R^2 between simulated and measured humidity values is 0.9740. The root mean square error is 2.61%, the maximum humidity error is 13.16%, and the average humidity error is 1.91%. The average relative error is 3.66%, and the maximum relative error is 22.24%. It can be seen that the simulated humidity value can accurately reflect the humidity of the brooder house at different ages.

According to Figures 10, the time period with large thermal errors is mainly from 12:00 to 14:00. Due to the hot weather in summer, the chicken house is ventilated most frequently during this period, leading to a lower predicted temperature of the chicken house than the measured one. Humidity forecast error mainly occurs on August 19 and September 11. Since chicks arrive at the chick farm at 6:00 on August 19, in order to conveniently record the chick's age, the chick's age is calculated from 00:00 on August 19 in the model, so the water vapor distributed by chicks will be included in the model. Therefore, the predicted humidity between 00:00 and 6:00 is greater than the actual humidity. The humidity forecast error on September 11 is greater than the average error

because the external humidity increased due to overcast and rainy weather. When the air in the chicken house is exchanged with the external air, the humidity entering the chicken house will be larger than usual, leading to a smaller predicted value than the actual value.

Analysis of the Simulation Results of the Microclimate Environment Regulation Model

From the weather data, on September 5, 2020, the highest temperature outside the brooder house was 31.43°C , the lowest temperature was 23.12°C , and the temperature difference was 8.31°C . The temperature outside the brood house fluctuated widely. Set the temperature in the brooder house at 30.5°C . By comparing the control results in Figures 11 and 12, when manual control and fuzzy decoupling PID control are

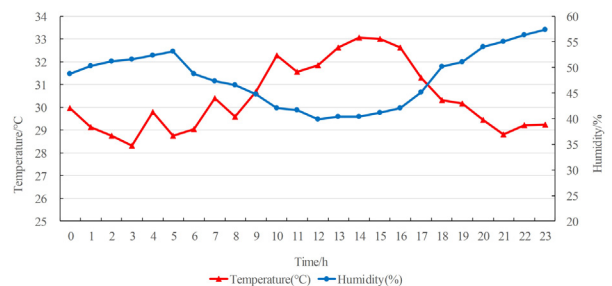

Figure 11. The manual control simulation.

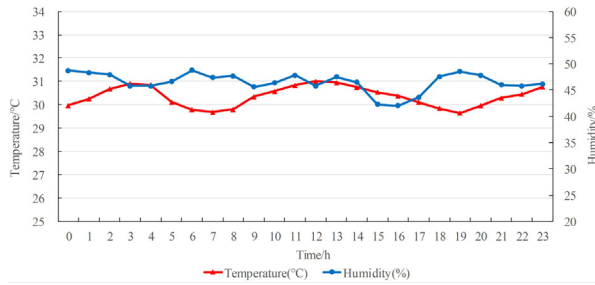

Figure 12. The fuzzy decoupling control simulation.

respectively adopted, the maximum temperature and minimum temperature of the brooder house controlled by manual control were 33.07°C and 28.3°C, the maximum temperature and minimum temperature of the brooder house controlled by fuzzy decoupling PID control were 31°C and 29.65°C, the maximum deviation errors between the temperature control result and the set value were 2.57°C and 0.5°C, respectively. The relative deviation errors were 8.43 and 1.64%, respectively. So the temperature fluctuation was small, the temperature control effect in brooding chicken house is more stable.

The relative humidity outside the brood house varied from 50.96 to 73.75%, and the relative humidity difference was 22.79%. Set the humidity setting value of brooding chicken house is 47%. By comparing the control results in Figures 11 and 12, when manual control and fuzzy decoupling PID control are respectively adopted, the maximum relative humidity and the minimum relative humidity of the brooder house controlled by manual control were 57.33 and 39.9%, respectively. Using fuzzy decoupling PID control, the maximum and the minimum relative humidity of brooder chicken house was 48.77 and 42.07%.the maximum deviation between the relative humidity control result and the set value are 10.33 and 4.93%, the relative deviation errors between the humidity control value and the set value are 21.98 and 10.49%, respectively, the fuzzy decoupling PID control within the range of the set value ($\pm 20\%$).The simulation results verify the effectiveness of the fuzzy decoupling PID control model and better meet the requirements of temperature and humidity control in the brood house.

Problems Needing Attention and Outlook

Under the background of animal welfare breeding and energy conservation breeding, it is very important to study the rationalization and conservation control of animal house environment. This paper conducts in-depth research on the coupling of temperature and humidity environmental factors in brooder house.

In this study, only temperature and humidity models are involved in the simulation model of the microclimate of the brooder house. In the follow-up study, the CO₂ concentration model and NH₃ concentration model

should be added to complete the microclimate model of the brooder house.

This study mainly constructs a microclimate model of the brooder house in summer in the northern region. Therefore, whether the method in this paper is suitable in the hot south or cold northeast regions needs further study.

CONCLUSIONS

The microclimate environment simulation model was established based on the analysis of the structural characteristics and environmental conditions of the brooder house. The decoupling compensation coefficient was obtained, and the fuzzy decoupling PID control strategy and model of the temperature and humidity environmental factors of the chicken house were established. The simulation shows that the maximum deviation between temperature and set value was 0.5°C, and the maximum relative error was 2.7%. The maximum deviation between relative humidity and set value was 4.93%, and the maximum relative error was 10.49%. The effectiveness of the control model was verified by comparing the effect of the control model with the artificial control effect. The simulation results provide a reference for the actual environmental control of the brooder house.

ACKNOWLEDGMENTS

This work is supported by the Key Research and Development Plan of Hebei Province (19226633D, 20327307D), the Science and Technology Research Project of Hebei Education Department (ZD2020145), Hebei Provincial Special Fund for Modern Agriculture Industry Technology Innovation Teams (HBCT2018060204).

DISCLOSURES

The authors declare that they have no known competing financial interests or personal relationships that could have appeared to influence the work reported in this paper.

REFERENCES

- Ai, H. B., J. H. Wei, Q. Qiu, and W. G. Zheng. 2013. Design of intelligent control system for micro plant factory. *Trans. CSAM* 44:198–204.
- Andretta, I., M. Kipper, G. D. Schirmann, C. S. Franceschina, and A. M. L. Ribeiro. 2021. Modeling the performance of broilers under heat stress. *Poult. Sci.* 100:101338.
- Azaza, M., K. Echaieb, F. Tadeo, E. Fabrizio, A. Iqbal, and A. Mami. 2015. Fuzzy decoupling control of greenhouse climate. *Arabian J. Sci. Eng.* 40:2805–2812.
- Cheng, Q. Y., Y. Mu, and B. Li. 2019. CFD simulation of the influence of air inlet position on air flow and temperature in a vertically ventilated laminated chicken house. *Trans. CSAE* 35:192–199.
- Groener, B., N. Knopp, K. Korgan, R. Perry, J. Romero, K. Smith, A. Stainback, A. Strzelczyk, and J. Henriques. 2015. Preliminary design of a low-cost greenhouse with open source control systems. *Procedia Eng* 107:470–479.
- Hassan, M. R., M. Rabbani, S. Sultana, and N. R. Sarker. 2018. Effects of strains and temperature on production performance, egg

- qualities and physiological response of laying hens. *Asian J. Anim. Vet. Adv.* 13:253–262.
- Kim, D. H., Y. K. Lee, S. H. Kim, and K. W. Lee. 2021. The impact of temperature and humidity on the performance and physiology of laying hens. *Animals* 11:56–67.
- Li, B. M., Y. Wang, W. C. Zheng, and Q. Tong. 2020a. Research progress in environmental control key technologies, facilities and equipment for laying hen production in China. *Trans. CSAE* 36:212–221.
- Li, H., L. Rong, and G. Zhang. 2017. Numerical study on the convective heat transfer of fattening pig in groups in a mechanical ventilated pig house. *Comput. Electron. Agric.* 149:90–100.
- Li, X. W., B. Xu, and Y. M. Yuan. 2020b. Research on temperature control system of piglet bed based on adaptive fuzzy PID algorithm. *J. Chin. Agric. Mech.* 41:48–53.
- Lin, Q. 2017. Influence of harmful gases in chicken house on chickens and its prevention and control progress. *Chin. Livest. Poult. Breed.* 11:143–144.
- Ma, C. W., and X. W. Miao. 2005. *Agricultural Biological Environmental Engineering*. China Agriculture Press, Beijing, China.
- Manonmani, A., T. Thyagarajan, M. Elango, and S. Sutha. 2018. Modelling and control of greenhouse system using neural networks. *Trans. Inst. Meas. Control* 40:918–929.
- Ni, J. Q., S. L. Liu, I. M. Lopes, Q. J. Xie, P. Zheng, and C. A. Diehl. 2017. Monitoring, modeling, and characterizing single-speed ventilation fans for an animal building. *Build. Environ.* 118:225–233.
- Oliveira, P. M., E. S. Pires, J. Boaventura-Cunha, and T. M. Pinho. 2020. Review of nature and biologically inspired metaheuristics for greenhouse environment control. *Trans. Inst. Meas. Control* 42:2338–2358.
- Quan, J. 2019. Research on solar greenhouse modeling and intelligent control strategy. PhD Diss. Univ. Tianjin Technology, Tianjin, China.
- Su, H. X., L. Q. Yan, H. C. Ren, and W. H. Liang. 2020. Control optimization of temperature and humidity in intelligent greenhouse. *IOT Technol* 10:98–100.
- Ulpiani, G., M. Borgognoni, A. Romagnoli, and C. D. Perna. 2016. Comparing the performance of on/off, pid and fuzzy controllers applied to the heating system of an energy-efficient building. *Energy Build* 116:1–17.
- Van, B. A., J. M. Aerts, P. Degraeve, and D. Berckmans. 2003. Quantification and control of the spatiotemporal gradients of air speed and air temperature in an incubator. *Poult. Sci.* 82:1677–1687.
- Wang, Y., W. C. Zheng, H. P. Shi, J. Tu, and B. M. Li. 2018. Roof insulation improving thermal environment and laying performance of poultry houses in summer. *Trans. CSAE* 34:207–213.
- Xie, Q. J., J. Q. Ni, J. Bao, and H. G. Liu. 2019. Simulation and verification of microclimate environment in closed swine house based on energy and mass balance. *Trans. CSAE* 35:148–156.
- Xie, Q. J., Z. B. Su, J. Q. Ni, and P. Zheng. 2017. Control system design and control strategy of multiple environmental factors in confined swine building. *Trans. CSAE* 33:163–170.
- Xu, F., J. Q. Sheng, J. L. Chen, and L. Qiu. 2007. Simulation of fuzzy expert control for greenhouse temperature based on MATLAB. *J. Syst. Simul.* 11:2464–2466.
- Yao, S. F. 2020. Importance of temperature and humidity to chicken feeding management. *Mod. Anim. Husb.* 2:10–11.
- Yin, J., Y. W. Yang, H. X. Cao, and Z. Y. Zhang. 2015. Greenhouse environmental monitoring and closed-loop control with crop growth model based on wireless sensors network. *Trans. Inst. Meas. Control* 37:50–52.
- Zhang, S. Y. 2018. Study on fine environment control methods for confined pig house in Northern China. PhD Diss. Univ. Northeast Agricultural, Harbin, China.
- Zhu, F., S. M. Zhu, Z. Y. Ye, and R. J. Zheng. 2014. Thermal simulation and test in closed-shading turtle greenhouse. *Trans. CSAE* 30:182–192.