



Horticultural Entomology

Wind Tunnel and Field Evaluation of Trapping Efficiency of Semiochemical Baited Camera-Traps for Capturing Codling Moth (Lepidoptera: Tortricidae)

Andrew J. Frewin,^{1,4} Christopher Adams,² Gary Judd,³ and Jordan Hazell¹

¹SemiosBio Technologies Inc., 22 East 5th Avenue, Suite 300, Vancouver BC V5T 1G8, Canada. ²Oregon State University, College of Agricultural Sciences, Mid-Columbia Agricultural Research and Extension Center, 3005 Experiment Station Drive, Hood River, OR 97031, USA, ³Agriculture and Agri-Food Canada, Summerland Research and Development Centre, 4200 Highway 97, Summerland, BC V0H 1Z0, Canada, and ⁴Corresponding author, e-mail: afrewin@semios.com

Subject Editor: Hannah Burrack

Received 21 January 2022; Editorial decision 10 August 2022.

Abstract

Sex pheromone baited monitoring traps are a critical tool for integrated pest management decisions against many insects, particularly codling moths (*Cydia pomonella* L.). The addition of cameras for remote monitoring has the potential to enhance the usefulness of these important tools. However, changes in trap design could potentially alter plume structure and trapping efficiency of these new traps. Here we look at several trap configurations designed to optimize the capture of codling moths in traps equipped with cameras. We found that, in both wind tunnel and field trials, camera equipped triangle traps and camera equipped rectangle traps (both V1 and V2) caught codling moths equivalent to a standard 'delta' style trap. While catch was unaffected, altering our rectangular trap opening from 4 to 8 cm (V1 and V2, respectively) decreased frequency of moths contacting the front of trap and increased the frequency of moths flying directly into the trap. We show that these novel camera equipped semiochemical-baited traps catch equivalent to the industry standard white delta trap.

Key words: horticultural entomology, IPM-agricultural, monitoring

Semiochemical-baited traps have been used to monitor codling moth *Cydia pomonella* (L.) (Lepidoptera: Tortricidae) in fruit orchards for over 40 yr (Butt et al. 1974, Maitlen et al. 1976, Knight and Light 2005a). Catch data are used to determine the temporal and spatial distribution of codling moth in orchards and inform pest management decisions. Monitoring traps are essential for establishing biofix (Riedl et al. 1976), timing pesticide applications (Gut and Wise 2016), and estimating pest populations (Adams et al. 2017a). Monitoring traps are also used to measure the effectiveness of mating disruption (Gut and Brunner 1998, Thomson et al. 2001, Miller and Gut 2015) and sterile insect release programs (Dyck et al. 1993, Judd 2016). While critically important to codling moth management, checking hundreds of traps over vast acres of commercial apple orchards is time consuming and labor intensive, leading some researchers to explore the possibility of making management decisions without traps (Jones et al. 2008). Nevertheless, trapping data is widely viewed as critical for accurate pest management decisions, and research has

shown that increasing the number of traps improves pest density estimates (Adams et al. 2017b). Recent advances in camera technology offer the possibility of collecting this important data in real time at a fraction of the time and cost.

In recent years there has been a growing interest in using digital cameras and other types of sensors for pest monitoring in a variety of agricultural settings (Epsky and Shuman 2001, Hahn et al. 2016, Potamitis et al. 2017, Zhu et al. 2017). One approach is to incorporate sensors directly into insect traps, such that the trap counting process can be automated (Doitsidis et al. 2017). Then by using wireless networking technologies, these 'internet of things' (IOT)-based traps can be accessed remotely, and pest capture data can be aggregated over large areas. This approach has several benefits, but most importantly, networked IOT-based traps could provide growers with data in real time. This would allow growers to implement pest management tactics sooner than would otherwise be possible, and potentially reduce crop losses. Camera traps are

particularly appealing in this regard as technicians can inspect trap images remotely to validate automated counts if necessary.

Various trap designs have been evaluated for monitoring codling moth (Vincent et al. 1990, Knight 2002) and related tortricid pests (Lewis and Macaulay 1976, Cha et al. 2013). Historically, codling moth traps have been made from inexpensive and disposable materials, such as cardboard or plastic in a variety of shapes. Much of the early research on codling moth monitoring was conducted using white wing-style traps (Butt et al. 1974, Proverbs et al. 1975, Riedl 1980, Beers et al. 1993). In the late 1990s (Gut and Brunner, 1998) the industry started to move to more durable plastic triangle (delta) style traps such as Scentry LP (Large Plastic Delta Trap, Scentry Biologicals, Billings, MT) and Trécé VI (Pherocon VI Delta trap, Trécé Inc., Adair, OK). While no differences were found between trap types (Knight et al. 2002) the durability of the plastic trap made it more desirable and it remains the standard today. The current technology for digital image capture and data transfer is still relatively large and requires secure housing to protect components from sun and rain. As such, IOT-traps will likely be bulkier, and made with more durable materials than conventional traps. It is important to confirm that these additional design features do not influence the efficacy of the trap.

Numerous factors can influence a trap's ability to catch a target insect, including trap placement within the tree canopy (Riedl et al. 1979) and within an orchard (Knight 2007). Trap color can influence captures for many day flying insects, particularly those with highly developed visual systems like pollinators (Campbell and Hanula 2007). However, the importance of trap color is less clear for nocturnal species like codling moth who have less developed visual systems (van der Kooi et al. 2021). Some research has suggested that orange traps catch more male codling moth than white traps, however in a wind tunnel this effect was only observed at 6 lux and not 2 lux, and color did not affect female moths regardless of light intensity (Knight and Miliczky 2003, Knight and Fisher 2006). However, other studies have found no effect of trap color on captures of codling moth, and related fruit tree pests, *Choristoneura rosaceana* (Harris), *Grapholita molesta* (Busck), and *Platynota idaeusalis* (Walker), (Myers et al. 2009). The main disadvantage of white colored traps is they catch more dipteran and hymenopteran bycatch (Knight and Miliczky 2003, Knight and Fisher 2006, Myers et al. 2009, Preti et al. 2020). However, in commercial settings, white delta traps are the industry standard (Doerr et al. 2004), with orange also used by a portion of the industry. As bycatch can interfere with digital observations, we selected red for our trap bodies, and compared it to the industry standard white.

The composition and dose of the semiochemical lure can also affect trap capture (Knight and Light 2005b, Judd 2016, Liu et al. 2016). For codling moth numerous lure formulation are commercially available and consist of various doses of the sex-pheromone codlemone, attractive to males, pear ester, attractive to females, or a combination thereof attractive to both sexes. The shape of a trap body and its openings determine the structure of the odor plume emanating from a trap and can influence trap captures (Lewis and Macaulay 1976). The structure of the plume affects the findability, the probability that an insect arrives at the trap, and the efficiency, the probability that an insect will enter the trap, and the retention, the probability that the insect stays in the trap (Miller et al. 2015). The measurement of the number of individuals arriving at the trap, divided by the number captured has also been defined as the capture rate (Pelozuelo and Frerot 2006, Carde et al. 2018). Understanding if and how changes to trap design impact capture rate, or trap efficiency, is critical to the successful adoption of IOT-traps.

In this study, we compare the efficacy of several IOT-traps with a white delta trap for monitoring codling moth (Fig. 1). The IOT-traps used in this study are based on a common platform, which consists of a weatherproof housing containing a digital camera, lights, and wireless networking components. First, we examine the behavioral response of male codling moth towards these traps in a wind tunnel, looking at the location of first contact with the trap. Then we examine the efficacy of these traps in two field experiments in commercial apple orchards. First in an orchard under area-wide sterile insect release-based management, and the second conducted in an orchard under mating disruption-based management.

Methods

Moths

Codling moths were obtained from the Okanagan-Kootenay Sterile Insect Release Program (OKSIR), Kelowna BC. Moths were reared according to established protocols (Dyck and Gardiner 1992). Unirradiated late instar larvae and pupae arrived in trays of artificial diet (Brinton et al. 1969) and were held in a controlled environmental chamber set to 23°C, 60% RH with a 16:8 (L:D) photoperiod, until the majority of larvae had pupated. Moth pupae were removed from the diet, sorted by sex (Peterson 1965), and male pupae were individualized in 30 ml portion cups. Isolated male pupae were held in a controlled environmental chamber as above. The chamber was checked daily for adult emergence, and only moths between 24 and 96 hr old were used in experiments.

Traps

In these experiments, several novel trap designs were evaluated, the Semios triangle trap in red, and the Semios rectangle trap in both red and white, with a 4 cm high opening (V1) and with a larger 8 cm high opening (V2) (Fig. 1, Table 1) (SemiosBio Technologies Inc, Vancouver, BC, Canada). These designs were compared to a white delta trap (PHEROCON VI Trap, Trécé Inc., Adair, OK). White delta traps were chosen for this experiment because they are the industry standard used in commercial orchards. All traps were fitted with appropriately sized sticky liners (Alpha Scents Inc, West Linn, OR) (Table 1). Traps were described in terms of their open space and closed space (Table 1). Here we defined open-space as the area of the opening where an insect can enter a trap (Fig. 1B). Closed space is defined as the area of the face of trap framing the open space (Fig. 1B). The trap body is defined as the trap surface not visible when viewed from the open end. The area of the trap opening of the Semios rectangle trap V1 was equivalent to the delta trap, however, the vertical dimension of the trap opening was smaller than the delta. The Semios rectangle V2 was modified from the V1 such that the vertical dimension of the trap opening was equal to the delta trap.

Wind Tunnel

Wind tunnel experiments were performed in the University of Guelph Engineering Boundary Layer Wind Tunnel (Brunskill and Lubitz 2012) in 2019. The wind tunnel has a cross section of 1.2 × 1.2 m and was 9.7 m long with a series of viewing and access ports along its length. All experiments were conducted in a 3 m long section at the intake end of the wind tunnel, separated from the rest of the tunnel by a mesh screen. The tunnel was illuminated from above with low levels of red incandescent light (ca. 3.2 lux). The wind tunnel was configured to produce a wind speed of 18 cm/s. Wind speed was measured with an Ultrasonic Anemometer Model 81000 (R. M. Young Company, Traverse City, MI) situated on the

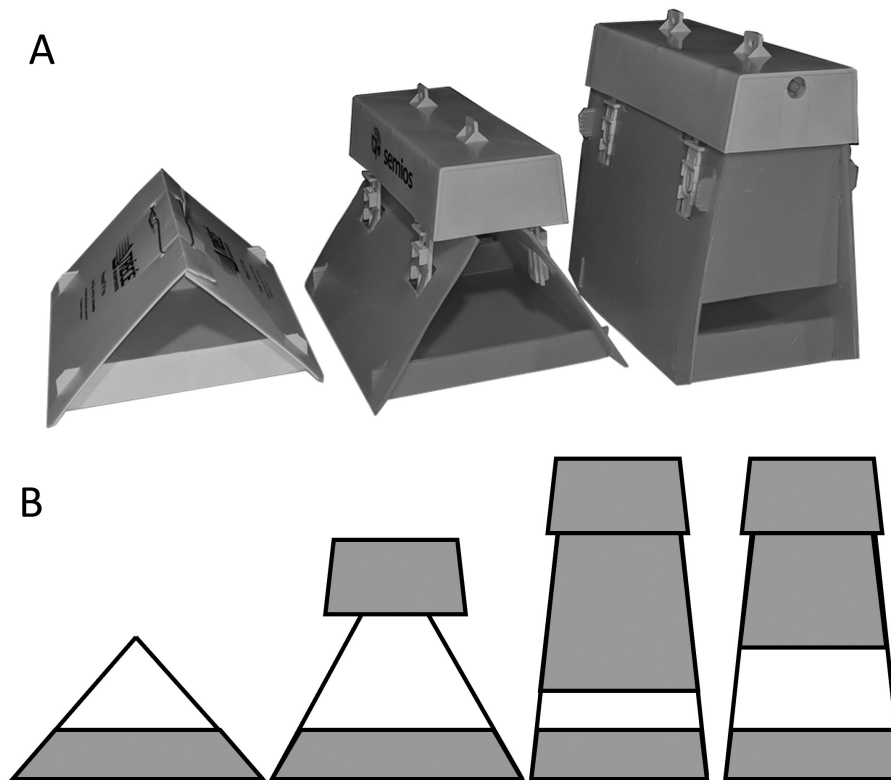

Fig. 1. A. Photograph of trap designs used in this study. Left to right; Trécé delta trap, Semios triangle trap, and Semios rectangle trap V1. B. Trap schematics illustrating open and closed space of (left to right) Trécé delta trap, Semios triangle trap, Semios rectangle trap V1 and V2. Here we defined closed space (shaded gray) as the surface area (cm^2) surrounding one (of the two) trap openings. Open space is defined as the trap opening or the area (cm^2) framed by the closed space. See [Table 1](#) for dimensions.

Table 1. Dimensions and color of traps used in wind tunnel and field trials with codling moth

Trap Characteristic	Trap type			
	Delta	Triangle	Rectangle V1	Rectangle V2
Color	White	Red	Red	Red
Exterior dimensions $L \times W \times H$ (cm)	27 × 20 × 11	27 × 20 × 18.5	24.5 × 14 × 24.5	24.5 × 14 × 24.5
Sticky liner dimensions $L \times W$ (cm)	20.3 × 17.8	20.3 × 17.8	17.8 × 12.7	17.8 × 12.7
Height of open space (cm)	8.0	9.8	4.0	8.0
Area of open space (cm^2)	50.0	100.5	50.4	96.0
Area of closed space (cm^2)	56.1	109.8	238.2	192.9
Ratio of open over closed space (%)	49.5	47.79	17.5	33.2

Open space and closed space values are for one end of the trap as in [Fig. 1B](#).

wind tunnel centerline behind the moth release platform. Due to the size and construction of the wind tunnel, it was not feasible to use intake and exhaust filters. However, the wind tunnel was housed in a large warehouse-type building that allowed the small amount of pheromone released from the pheromone lure to exhaust out of the tunnel, on the downwind end, and dissipate into the larger space.

One hour before scotophase, individualized adult male codling moths were placed in a cooler on ice for ca. 10 min. Moths were then transferred individually to 3 × 3 cm cylindrical aluminum mesh cages. Mesh cages were then acclimated in the wind tunnel facility until the start of experiments. Individual cages were cleaned with Fisherbrand Sparkleen 1 Detergent (Fisher Scientific Co., Pittsburgh, PA) between uses and were not reused for at least

3 d. Moth flights were conducted ca. 5 min after the onset of scotophase and conducted for no longer than 2.5 hr a day, at a temperature of 26°C.

In the wind tunnel experiments, we evaluated, the red Semios rectangle trap (V1 and V2) and the red Semios triangle trap ([Fig. 1](#), [Table 1](#)). These designs were compared to a white delta trap (PHEROCON VI Trap, Trécé Inc., Adair, OK). For the wind tunnel experiments, traps were baited with a single 10 μg codlemone lure placed on its side at the center of the sticky liner ([Judd et al. 2005](#)). Three experiments were conducted, 1) a comparison between the delta and rectangle trap V1, 2) a comparison between the delta and triangle traps, and 3) a comparison between the delta trap, and Semios rectangle trap V1 and V2.

Traps were hung from the roof of the wind tunnel, parallel to the wind direction, such that the open ends of the traps faced directly upwind and downwind, with the center of the trap opening located at the center of the wind tunnel cross section (i.e., 0.6 m from the walls of the tunnel). A release platform fixed to a retort stand was located 1.5 m downwind of the trap at the center-point of the wind tunnel cross section. Mesh cages with individual moths were introduced to the pheromone plume by placing the cage on the release platform. After ca. 15 s in the pheromone plume a nylon lead clipped to the lid of the mesh cage was pulled, from outside of the tunnel, lifting the lid and releasing the moth. The moths' behavior was observed for 2 min, and the occurrence of the following behaviors and events were recorded: wing fanning, upwind flight, contact with, and capture in the trap. Moths were also scored for the location where they first contacted the trap. Location of contact had three categories, contacting the closed space (lip and/or baffle), entering the trap directly, or contacting the trap body. Moths which exhibited poor flight ability were excluded from the analysis. This manifested as moths would 'jump' but never exhibit sustained flight.

Flight experiments were conducted such that each day's flight period was divided into two or three equal time periods, during which a similar number of moths were flown to a specific trap. The order in which traps were tested was randomized between days such that each trap was tested during each time period in a given experiment, this was repeated four times in experiment one and two, and three times for experiment three. This design was chosen to control for potential variability in male codling moth response across scotophase (Castroville and Carde 1979).

To visualize the plume structure generated by the traps, we used a Model 5 Console, Helium Bubble Generator (Sage Action, Inc., Pinetop-Lakeside, AZ). The helium bubble generator produced ~4 mm helium filled bubbles, which were released upwind and in line with the trap in the wind tunnel. The neutrally buoyant bubbles follow fine scale air currents through and around the traps. Videos of this process were taken and compiled into representative diagrams that illustrate the airflow patterns in and around trap bodies. Video was recorded with using Canon EOS T2i digital camera set to movie mode. Still frames were exported from videos files and compiled manually using GNU Image Manipulation Program (v. 2.10.18, The GIMP Development Team). The wind speeds of the helium-bubble image-capture experiments were identical to those used in the moth flight experiments. The resultant airflow diagrams were used to approximate pheromone filaments emitted from various trap designs.

2014 Field Experiment

In 2014, we conducted a field experiment in a 3.3 ha organically certified high-density apple orchard located in Cawton, BC. Here we compared codling moth captures between the red Semios rectangle trap V1, white Semios rectangle trap V1, and the white delta trap (Fig. 1, Table 1). In 2014 traps were baited with CM L2 Lure (Trécé Inc., Adair, OK) and lures were replaced every 4 wk. Lures were hung from the center of the trap roof (Adams et al. 2017), and traps were hung in the upper third of the tree canopy. Catch data was recorded manually and sticky liners replaced, weekly.

The orchards were divided into twelve trap locations on a 3 × 4 grid. Traps within rows were separated by 60 m, and rows were separated by 50 m. No traps were placed within 20 m of the edge of the orchard. Four traps of each trap type were randomly assigned to a trap location each week for 12 wk, between June and August, using an RCB design. Groups of male and female sterile codling moth were released into the orchard at a rate of ca. 324 moths per ha per week.

2017 Field Experiment

In 2017, we conducted field experiments in an organically certified high-density apple orchard located in Orondo, WA, where mating disruption was used for codling moth management. In this experiment, we compared codling moth trap captures between the red Semios rectangle trap, red Semios triangle trap, and the white delta trap (Fig. 1, Table 1). In 2017 traps were baited with CMDA lures (Trécé Inc., Adair, OK), and lures were replaced every 4 wk. CMDA lures were used in this trial because of the use of mating disruption at these orchards. Lures were hung from the center of the trap roof (Adams et al. 2017), and traps were hung in the upper third of the tree canopy. This 23 ha orchard was divided into nine trap locations, consisting of 2–3 ha blocks, minimum distance between traps was 140 m. No traps were placed within 20 m of the orchard edge. Three traps of each trap type were randomly assigned to a trap location each week between June and September using an RCB design. Trap captures were manually recorded and sticky liners were replaced weekly.

Statistical Analysis

All data analyses were performed at a significance level of $\alpha = 0.05$ in R v3.5.1 (R Development Core Team 2015). Number of moths, which 1) flew upwind towards the trap, 2) contacted the trap, and 3) were captured by trap, were analyzed with a generalized linear model with a binominal distribution. Variance was partitioned into the fixed effects of trap type, day of experiment, and their interaction. Likelihood ratio test was used to assess significant effects, and Tukey's HSD was used to separate means. To analyze the location of first contact, data within experiments were pooled across days and analyzed as above, with only trap type as a fixed effect. To determine if pheromone habituation within the wind tunnel facility influenced moth behavior, a logistic regression was used to examine the relationship between minutes into scotophase and wing fanning for all three experiments.

Data from each field study was analyzed with a generalized linear mixed model with a negative binominal distribution. Variance was partitioned into the fixed effect of trap type, and the random effects of trap location and week of observation. Likelihood ratio test were used to assess significant effects, and Tukey's HSD was used to separate means. All models were validated by inspecting residual plots.

Results

Wind Tunnel Experiments 1–3

Both within and between wind tunnel experiments, the various traps performed similarly (Table 2, Supp Table 1 [online only]). Moth behavioral response toward the various traps was consistent within each of the three experiments, as indicated by the lack of any significant effects involving day (Supp Table 1 [online only]). Importantly there were no significant differences between trap types in the proportion of moths that flew upwind toward traps, contacted the traps, or were captured by the traps (Table 2). The majority of moths (98.5%, $n = 350$) which contacted a trap were ultimately captured by it (Table 2). The proportion of moths that exhibited wing-fanning behaviour after introduction into the wind tunnel did not change over time during our experiments (Experiment 1: $\chi^2 = 0.34$, $df = 1$, $P = 0.56$; Experiment 2: $\chi^2 = 5.053$, $df = 1$, $P = 0.17$; Experiment 3: $\chi^2 = 0.58$, $df = 1$, $P = 0.75$).

For moths that were caught, the location where moths first contacted the trap was affected by trap type (Fig. 2, Supp Table 2 [online only]). The majority of moths flown to delta traps (62.1%,

$n = 161$) and triangle traps (69.1%, $n = 68$) entered the trap's open space, avoiding contact with the exterior surface. In contrast, 74.3% of moths ($n = 74$) captured by the rectangle trap V1 contacted closed space on the front of the trap before being captured (Fig. 2). Of these moths ($n = 55$), 14.55% contacted the trap lip (below the trap opening), with the remaining 85.45% contacting the trap baffle (above the trap opening) before being caught. In experiment three, increasing the opening height (and area) of the rectangle trap V2 compared to V1 resulted in fewer contacts with the closed space on the front of the trap and more moths directly entering the trap opening. (Fig. 2). In this case, the proportion of moths that contacted the lip and baffle were 78.95 and 21.05% ($n = 19$), respectively.

2014 Field Experiment

In this experiment only sterile codling moths were detected in traps, no wild-type moths were caught for the duration of the experiment. Codling moth capture varied across time (Supp Fig. 1 [online only]) but mean codling moth capture was not affected by the trap type ($\chi^2 = 5.85$, $df = 2$, $P = 0.054$) (Fig. 3). In general, trap captures increased from June 2nd until mid-July after which captures decreased. When analyzing for random effects, 97.78% (2.30 ± 1.52) of the variance was due to sampling date, while only 2.22% (0.052 ± 0.23) was due to trap position within the orchard.

2017 Field Experiment

Codling moth capture varied across time (Supp Fig. 2 [online only]). However, the number of codling moth captured was not affected by trap type ($\chi^2 = 4.43$, $df = 2$, $P = 0.11$) (Fig. 4). When analyzing random effects, 37% (1.04 ± 1.02) of the variance was due to

sampling date, while 63% (1.79 ± 1.34) was due to trap position within the orchard (Supp Fig. 2B [online only]).

Discussion

In these experiments, we compared the efficacy of novel IOT enabled codling moth traps to a standard delta trap in a series of wind tunnel and field-based experiments. Our primary interest was to assess the relative performance of these IOT enabled traps with a commercial standard. In both wind tunnel and field experiments, the Semios camera traps caught codling moth equivalent to a standard delta trap. In wind-tunnel experiments, we observed that male moth landing behavior was different for the Semios rectangle V1 trap vs. the V2, but this difference did not translate into a difference in catch.

In our wind tunnel experiments, male codling moth's behavior towards the various traps was consistent both within and between experiments. The proportion of moths exhibiting wing-fanning was consistent over the course of the experiment, which suggests there was no pheromone habituation in these experiments and importantly there were no differences in upwind flight, trap contact, or trap capture. The location of first contact with a trap has been shown to influence the capture rate of codling moths (Knight 2002), so we recorded the instance and location of this contact. We observed that significantly more moths contacted the front of the rectangle trap V1 than the front of the delta trap. However, in our study, the vast majority of moths that contacted a trap ultimately entered it and were caught (Table 2). When moths landed on the front of the V1 rectangle trap, 85% landed on the baffle above the trap opening. The baffle of the V1 trap was designed to reduce the trap opening thereby

Table 2. Proportion (\pm SE) of male codling moths exhibiting listed behaviors in response to codlemone baited traps in a wind tunnel

Trap	Experiment 1		Experiment 2		Experiment 3		
	Delta	Rectangle V1	Delta	Triangle	Delta	Rectangle V1	Rectangle V2
<i>n</i>	70	55	90	91	56	49	56
Upwind flight	95.7 \pm 2.4 a	96.4 \pm 2.5 a	97.8 \pm 1.6 a	96.7 \pm 1.9 a	98.2 \pm 1.8 a	95.9 \pm 2.8 a	98.2 \pm 1.8 a
Contact	78.6 \pm 5.0 a	78.2 \pm 5.6 a	76.7 \pm 4.5 a	74.7 \pm 4.6 a	67.9 \pm 6.2 a	71.4 \pm 6.5 a	75.0 \pm 5.8 a
Capture	77.1 \pm 5.0 a	74.5 \pm 5.9 a	76.7 \pm 4.5 a	74.7 \pm 4.6 a	67.9 \pm 6.2 a	67.4 \pm 6.7 a	75.0 \pm 5.8 a

Proportions followed by different letters in a row, within an experiment, are significantly different ($\alpha = 0.05$).

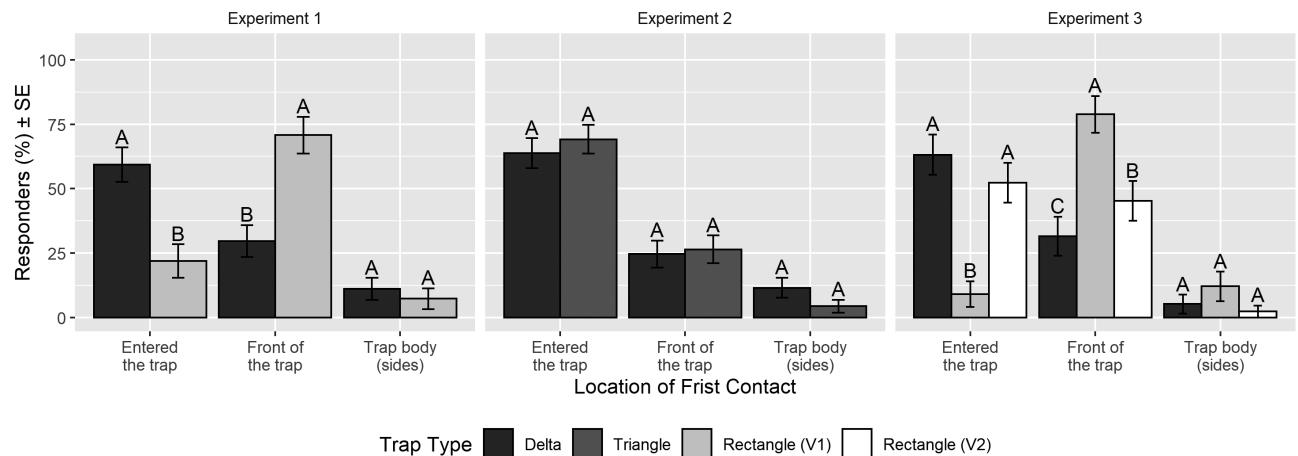

Fig. 2. Location of first contact of male codling moths approaching various traps baited with codlemone lures in a wind tunnel. Means with different letters between trap types are significantly different ($\alpha = 0.05$).

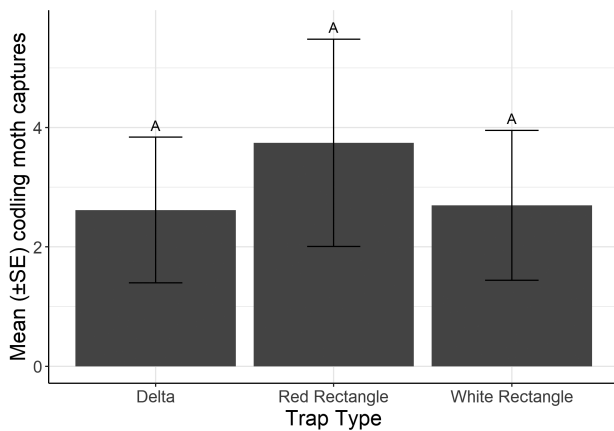

Fig. 3. Mean (\pm SE) codling moth trap capture by trap type for the 2014 field experiment in high density organically certified apple orchard, with weekly release of sterile codling moths. Means with different letters are significantly different ($\alpha = 0.05$).

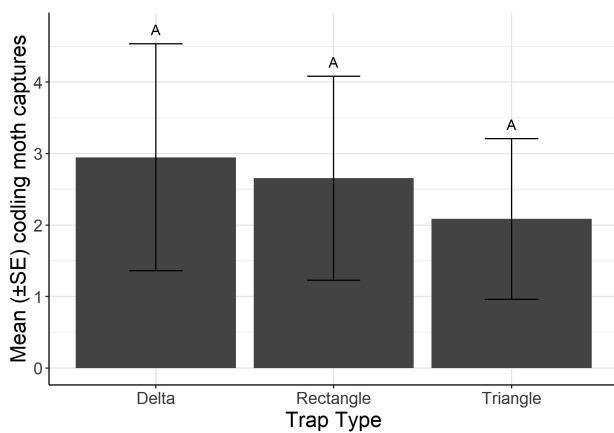

Fig. 4. Mean (\pm SE) codling moth trap capture by trap type for the 2017 field experiment conducted in high density organically certified apple orchard employing codling moth mating disruption. Means with different letters are significantly different ($\alpha = 0.05$).

reducing bycatch. However, this baffle changed airflow and provided a large surface area for moths to alight on. While we did not see a reduction in mean catch, we wanted to decrease the instances of landing on the outside of the trap and increase the probability of moths entering directly into the trap and contacting the sticky card. To that end, the rectangle trap was modified to the V2 with a larger opening. Moth behavior towards the Semios rectangle trap V2 was similar to the delta trap and triangle trap in the proportion of moths directly entering the trap. When moths contacted the front of V2 trap 21.05% landed on the smaller baffle and 78.95% on the lower lip. Since mean capture was not different, it is unlikely that this change has any practical significance in terms of pest monitoring. However, the larger opening allows more bycatch to enter the trap, which could be significant as it may interfere with the camera's ability to capture images of codling moths, and may necessitate more frequent liner replacements.

The wind tunnel provided important first-hand observations of moth behavior and allowed us to visualize turbulent airflow with helium bubbles. While airflow in this experimental design may be more idealized than actual field conditions or flight tunnels typically employed in pheromone research (Baker and Linn 1984), we believe

they provide valuable insights. When moths approached the V1 rectangle trap, a typical flight path involved contact with the baffle above the trap opening, followed by a short period of a relatively stationary but drifting flight directly in front of the baffle. After a time, the moth would descend down in front of the trap opening and enter. We believe this behavior is a result of wind currents/turbulence created by the trap itself. Visualizations generated using the helium bubble generator support this hypothesis (Fig. 5). These visualizations revealed a vortex above the rectangle V1 trap opening (Fig. 5C) in the same position in which moths would hover while making contact with the baffle. This vortex consisted of air exiting the trap opening and flowing upward and then back toward the trap itself, in flight experiments this vortex would have contained filaments of pheromone. Interestingly a smaller, and less stable vortex was occasionally observed below the trap opening for all traps tested, and in all experiments some moths would contact the trap lip before entering. Based solely on the ratio of open space (Table 1), we would expect more turbulence to be generated in the wake of the rectangle trap V1 compared to either the triangle, rectangle trap V2, or delta traps, with their more open designs. This turbulence would likely influence pheromone plume structure and potentially final-approach flight behavior (Mafraneto and Carde 1994). Interestingly, fewer moths flown to the V1 trap (14.55%) alighted on the lip below the trap opening compared to the V2 trap (78.95%). We suspect this pattern is a result of the pheromone lure being placed on the sticky liner. In this scenario, we would expect more pheromone filaments in the vortex below the trap entrance than above it. Helium bubbles visually provide some evidence for this, the trajectory of many bubbles passing through the V2 trap (Fig. 5D) was more inline with the direction of the wind compared to the V1 (Fig. 5C). Since more air was flowing undistributed through the trap above the lure, we would suspect fewer pheromone filaments being deflected upwards.

Pheromone plume structure is known to influence trap capture. In experiments with the pea moth (*Cydia nigricana* F.), traps that generated narrower, more concentrated pheromone plumes caught more moths than traps that generated diffuse pheromone plumes (Lewis and Macaulay 1976). In our field studies, all traps caught similar numbers of codling moth, even though we suspected the plume structure of the rectangle trap V1 to be slightly different than the delta or triangle traps. This difference was supported by our wind tunnel experiments, where we observed different moth approach behaviors just outside the trap.

Plume structure will also be influenced by the physical environment in which the trap is located. In complex environments, such as an orchard canopy, atmospheric conditions may cause greater dispersal of pheromone compared to less complex environments such as low-growing vegetative crops, as seen in Lewis and Macaulay (1976). The estimated plume reach of a delta trap fitted with a codlemone lure in an apple orchard is <5 m (Adams et al. 2017), much shorter than plume reach estimates for other moth species when measured in more open environments (Baker and Roelofs 1981; Elkinton et al. 1984). The practical implication of this is that the influence of trap shape on pheromone plume structure may not be as important for codling moth, and other moths living in complex environments such as orchards and other forms of permaculture.

In our 2014 field trial, we found no difference between the white delta trap and the red and white Semios rectangle V1 traps when deployed in a high-density orchard subjected to sterile insect release. During this experiment, we did not catch any wild-type moths. Under these conditions, sampling date had an effect on trap captures whereas trap location did not. The seasonal pattern of trap captures (Supp Fig. 1 [online only]) was likely influenced by local

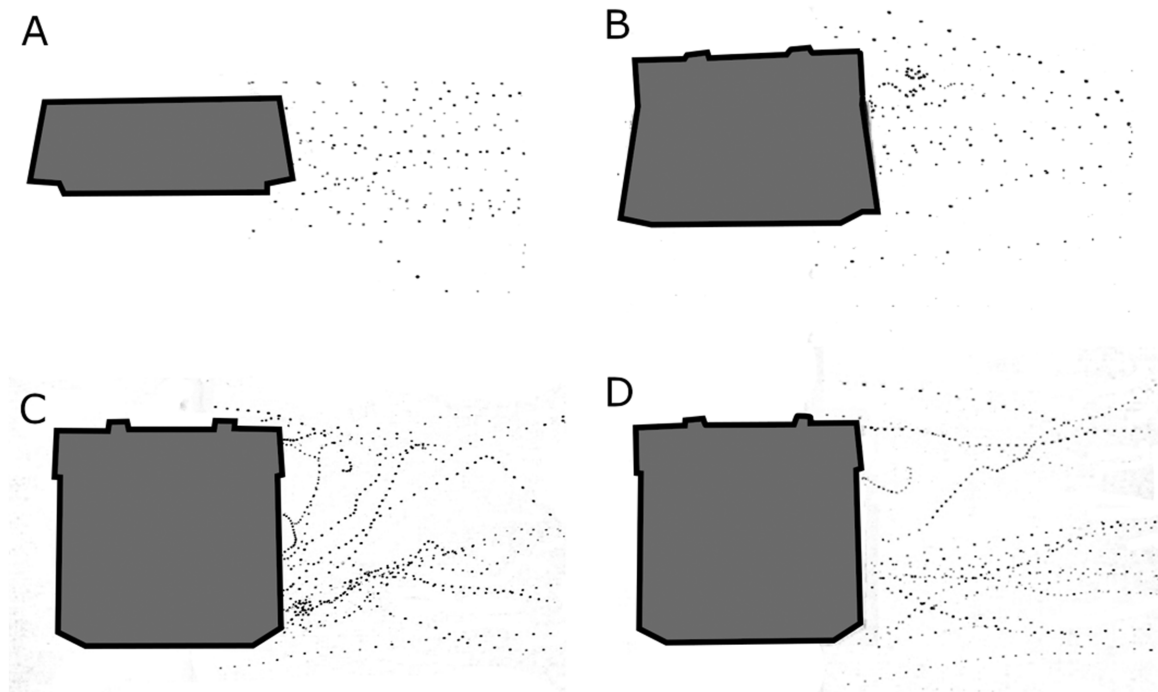

Fig. 5. Side view of various traps. This diagram is compiled from still frames of video recording of helium bubbles passing through traps in a wind tunnel. Air current flows from left to right. Diagram of air currents flowing from a delta trap (A), Semios triangle trap (B), Semios rectangle trap V1 (C), and Semios rectangle trap V2 (D).

temperature. Where flight behavior of the sterile moths and therefore trap captures peaked in the first three weeks of July, and was lower in both June and August. In this trial we saw no difference between red and white colored versions of the Semios rectangle V1 trap. In our experience we found less bycatch using the red version of the Semios rectangle V1 trap.

In our 2017 field trial, we found no difference between the white delta trap, and red Semios triangle, or red Semios rectangle V1 traps when deployed in an orchard under commercial codling moth mating disruption. Under the conditions of this experiment, we found that both sample date and trap location had a significant effect on the number of moths captured. The codling moth sampled in this experiment originated from a natural infestation where we would expect more spatial variation in pest density, particularly when compared to the conditions in 2014 conducted under sterile insect release.

We did not control for trap color in these experiments. The delta traps used in these experiments were white (the industry standard), while the triangle and rectangle traps used in the wind tunnel experiments and 2017 field trials were red. While there are a few papers that report slight differences in catch by color, others have reported no effects of trap color on codling moth trap capture (Myers et al. 2009). We found no evidence that color influenced male codling moth trap captures in the 2014 field trial when comparing the white and red rectangle traps. The 2017 field experiment was conducted under mating disruption using female attractive lures. Based on earlier research (Knight and Fisher 2006, Barros-Parada et al. 2013), we did not expect to find a difference in female catch by trap color.

Monitoring with semiochemical baited traps is a critical component of codling moth management. Current recommendations for monitoring codling moth are to assess trap captures at weekly intervals during periods of adult flights and recommendations

for trap density range from as low as 0.4 trap/ha up to 1 trap/ha. Although critical for pest management, collecting trap count data and converting those counts into actionable reports is both labor-intensive and time-consuming. From our experience, many growers, for either logistic and/or financial reasons, use fewer traps per ha and monitor those traps less frequently than recommended. However, by employing IOT-based insect traps it may be possible to automate and thus reduce labor costs associated with monitoring. For example, in an analysis of 6 yr of data from an area-wide codling moth monitoring program, it was found that only 47% of traps in any given year had caught a moth (Gill 2014). In this example, if these traps only required service once every 4 wk, to replace lures and liners, this would have reduced labor costs by 35.25%. Additional savings are likely as many traps with low catches would require service only occasionally.

This research provides evidence that IOT-based traps, baited with sex pheromone lures, perform as well as currently used standard delta traps. Here we show that two IOT-based codling moth traps perform in a similar fashion to commonly used delta trap in both a wind tunnel and in two field trials. This study also emphasizes the importance of revisiting IPM monitoring methods and equipment in the context of new digital technologies. Knowing that the IOT-traps tested caught no differently than standard white delta traps means that these traps can be adopted without concerns over impacting current action thresholds established with other traps. This is critical as IOT traps offer improved monitoring capabilities at substantial labor savings. IOT traps also offer the possibility of collecting real time data that will improve pest management decisions. To be widely accepted, IOT-based traps must perform as well as commercial standards, such that trap capture can be interpreted in the context of available pest management literature and industry practices. This paper should serve as a guide for others as future IOT traps designs are developed.

Conflict of Interest

This work was funded by SemiosBio Technologies Inc. AJF, and JH were employees of SemiosBio Technologies Inc. at the time this work was conducted.

Supplementary Data

Supplementary data are available at *Journal of Economic Entomology* online.

References Cited

- Adams, C. G., P. S. McGhee, J. H. Schenker, L. J. Gut, and J. R. Miller. 2017b. Line-Trapping of codling moth (Lepidoptera: Tortricidae): a novel approach to improving the precision of capture numbers in traps monitoring pest density. *J. Econ. Entomol.* 110: 1508–1511.
- Adams, C. G., J. H. Schenker, P. S. McGhee, L. J. Gut, J. F. Brunner, and J. R. Miller. 2017a. Maximizing information yield from pheromone-baited monitoring traps: estimating plume reach, trapping radius, and absolute density of *Cydia pomonella* (Lepidoptera: Tortricidae) in Michigan apple. *J. Econ. Entomol.* 110: 305–318.
- Baker, T. C., and C. E. Linn. 1984. *Wind tunnels in pheromone research*, pp. 75–110. Springer-Verlag, New York.
- Baker, T. C., and W. L. Roelofs. 1981. Initiation and termination of oriental fruit moth male-response to pheromone concentrations in the field. *Environ. Entomol.* 10: 211–218.
- Barros-Parada, W., A. L. Knight, E. Basoalto, and E. Fuentes-Contreas. 2013. An evaluation of orange and clear traps with pear ester to monitor codling moth (Lepidoptera: Tortricidae) in apple orchards. *Cienc. Investig. Agrar.* 40: 307–315.
- Beers, E., J. Brunner, M. Willett, G. Warner. 1993. *Orchard pest management: a resource book for the pacific northwest*. Good Fruit Grower, Yakima, WA, USA.
- Brinton, F. E., M. D. Proverbs, and B. E. Carty. 1969. Artificial diet for mass production of codling moth, *Carpocapsa pomonella* (Lepidoptera – Olethreutidae). *Can. Entomol.* 101: 577.
- Brunskill, A. W., and W. D. Lubitz. 2012. A neural network shelter model for small wind turbine siting near single obstacles. *Wind Struct.* 15: 43–64.
- Butt, B. A., T. P. McGovern, M. Beroza, and D. O. Hathaway. 1974. Codling moth – cage and field evaluations of traps baited with a synthetic sex attractant. *J. Econ. Entomol.* 67: 37–40.
- Carde, R. T., J. Bau, and J. S. Elkinton. 2018. Comparison of attraction and trapping capabilities of bucket- and delta-style traps with different pheromone emission rates for Gypsy moths (Lepidoptera: Erebidae): implications for understanding range of attraction and utility in surveillance. *Environ. Entomol.* 47: 107–113.
- Castroville, P. J., and R. T. Carde. 1979. Environmental-regulation of female calling and male pheromone response periodicities in the codling moth (*Laspeyresia-pomonella*). *J. Insect Physiol.* 25: 659–667.
- Cha, D. H., S. P. Hesler, C. E. Linn, A. J. Zhang, P. E. A. Teal, A. L. Knight, W. L. Roelofs, and G. M. Loeb. 2013. Influence of trap design on upwind flight behavior and capture of female grape berry moth (Lepidoptera: Tortricidae) with a Kairomone lure. *Environ. Entomol.* 42: 150–157.
- Campbell, J. W., and J. L. Hanula. 2007. Efficiency of Malaise traps and colored pan traps for collecting flower visiting insects from three forested ecosystems. *J. Insect Conserv.* 11: 399–408.
- Doerr, M., J. Brunner, J. Dunley, and T. Smith. 2004. Special report: conquering codling moth. *Western Fruit Grower.* 124: 1–8.
- Doitsidis, L., G. N. Fouskitakis, K. N. Varikou, Rigakis, II, S. A. Chatzichristofis, A. K. Papafilippaki, and A. E. Birouraki. 2017. Remote monitoring of the *Bactrocera oleae* (Gmelin) (Diptera: Tephritidae) population using an automated McPhail trap. *Comput. Electron. Agric.* 137: 69–78.
- Dyck, V. A., and M. G. T. Gardiner. 1992. Sterile-insect release program to control the codling moth *Cydia-pomonella* (L) (Lepidoptera, Olethreutidae) in British-Columbia, Canada. *Acta Phytopathol. Entomol. Hung.* 27: 219–222.
- Dyck, V. A., S. H. Graham, and K. A. Bloem. 1993. Implementation of the sterile insect release programme to eradicate the codling moth, *Cydia pomonella* (L) (Lepidoptera: Olethreutidae), in British Columbia, Canada, pp 285–298. In *Management of Insect Pests: Nuclear and Related Molecular and Genetic Techniques. Proceedings of a symposium Vienna 19–23 October 1992*. International Atomic Energy Agency (IAEA). Vienna.
- Elkinton, J. S., R. T. Carde, and C. J. Mason. 1984. Evaluation of time-average dispersion models for estimating pheromone concentration in a deciduous forest. *J. Chem. Ecol.* 10: 1081–1108.
- Epsky, N. D., and D. Shuman. 2001. Laboratory evaluation of an improved electronic grain probe insect counter. *J. Stored Prod. Res.* 37: 187–197.
- Gill, P. 2014. Statistical analysis of codling moth prevalence and fruit damage data. http://www.oksir.org/wp-content/uploads/2016/08/SIR_Report_PGill_June15_2014.pdf (Accessed 20 September 2021).
- Gut, L. J., and J. F. Brunner. 1998. Pheromone-based management of codling moth (Lepidoptera: Tortricidae) in Washington apple orchards. *J. Agric. Entomol.* 15: 387–406.
- Gut, L., and J. Wise. 2016. Codling moth integrated pest management. In J. Wise, L. J. Gut, R. Isaacs, A. M. C. Schilder, G. W. Sundin, B. Zandstra. (eds.), *2016 Michigan fruit management guide*. Michigan State University Extension Bulletin E154, East Lansing, MI.
- Hahn, F., A. Guerrero, E. Cruz, and M. Hidalgo. 2016. Evaluation of energy consumption and environmental conditions of a wireless network and automated fly trap of greenhouse tomato plants. *Entomol. Appl. Sci. Lett.* 3: 9–15.
- Jones, V. P., M. Doerr, and J. F. Brunner. 2008. Is biofix necessary for predicting codling moth (Lepidoptera: Tortricidae) emergence in Washington State apple orchards? *J. Econ. Entomol.* 101: 1651–1657.
- Judd, G. J. R. 2016. Potential for using acetic acid plus pear ester combination lures to monitor codling moth in an SIT program. *Insects.* 7: 68.
- Judd, G. J. R., M. G. T. Gardiner, N. C. DeLury, and G. Karg. 2005. Reduced antennal sensitivity, behavioural response, and attraction of male codling moths, *Cydia pomonella*, to their pheromone (E,E)-8,10-dodecadien-1-ol following various pre-exposure regimes. *Entomol. Exp. Appl.* 114: 65–78.
- Knight, A. L. 2002. Flight tunnel and field evaluations of sticky traps for monitoring codling moth (Lepidoptera: Tortricidae) in sex pheromone-treated orchards. *J. B. C. Entomol. Soc.* 99: 107–116.
- Knight, A. L. 2007. Influence of within-orchard trap placement on catch of codling moth (Lepidoptera: Tortricidae) in sex pheromone-treated orchards. *Environ. Entomol.* 36: 425–432.
- Knight, A. L., and J. Fisher. 2006. Increased catch of codling moth (Lepidoptera: Tortricidae) in semiochemical-baited orange plastic delta-shaped traps. *Environ. Entomol.* 35: 1597–1602.
- Knight, A. L., and D. M. Light. 2005a. Seasonal flight patterns of codling moth (Lepidoptera: Tortricidae) monitored with pear ester and codlemone-baited traps in sex pheromone-treated apple orchards. *Environ. Entomol.* 34: 1028–1035.
- Knight, A. L., and D. M. Light. 2005b. Dose-response of codling moth (Lepidoptera: Tortricidae) to ethyl (E, Z)-2,4-decadienoate in apple orchards treated with sex pheromone dispensers. *Environ. Entomol.* 34: 604–609.
- Knight, A. L., and E. Miliczky. 2003. Influence of trap colour on the capture of codling moth (Lepidoptera: Tortricidae), honeybees and non-target flies. *J. Entomol. Soc. B. C.* 100: 65–70.
- Lewis, T., and E. D. M. Macaulay. 1976. Design and elevation of sex-attractant traps for pea moth, *Cydia nigricana* (Steph.) and the effect of plume shape on catches. *Ecol. Entomol.* 1: 175–187.
- Liu, W., J. Xu, and R. Z. Zhang. 2016. The optimal sex pheromone release rate for trapping the codling moth *Cydia pomonella* (Lepidoptera: Tortricidae) in the field. *Sci. Rep.* 6: 10.
- Mafraneto, A., and R. T. Carde. 1994. Fine-scale structure of pheromone plumes modulates upwind orientation of flying moths. *Nature.* 369: 142–144.
- Maitlen, J. C., L. M. McDonough, H. R. Moffitt, and D. A. George. 1976. Codling moth Lepidoptera-Olethreutidae sex-pheromone - baits for mass trapping and population survey. *Environ. Entomol.* 5: 199–202.
- Miller, J. R., and L. J. Gut. 2015. Mating disruption for the 21st century: matching technology with mechanism. *Environ. Entomol.* 44: 427–453.
- Myers, C. T., G. Krawczyk, and A. M. Agnello. 2009. Response of tortricid moths and non-target insects to pheromone trap color in commercial apple orchards. *J. Entomol. Sci.* 44: 69–77.

- Pelozuelo, L., and B. Frerot. 2006. Behaviour of male European corn borer, *Ostrinia nubilalis* Hubner (Lep.: Crambidae) towards pheromone-baited delta traps, bucket traps and wire mesh cone traps. *J. Appl. Entomol.* 130: 230–237.
- Peterson, D. M. 1965. A quick method for sex determination of codling moth pupae. *J. Econ. Entomol.* 58: 576–577.
- Preti, M., A. Knight, and S. Angeli. 2020. Improved monitoring of *Grapholita molesta* (Lepidoptera: Tortricidae) in stone fruit orchards with a Pheromone-Karimone Combination lure. *Insects.* 11: 412. doi: [10.3390/insects11070412](https://doi.org/10.3390/insects11070412)
- Proverbs, M. D., D. M. Logan, and J. R. Newton. 1975. A study to suppress codling moth (Lepidoptera: Olethreutidae) with sex pheromone traps. *Can. Entomol.* 107: 1265–1269.
- Potamitis, I., P. Eliopoulos, and I. Rigakis. 2017. Automated remote insect surveillance at a global scale and the internet of things. *Robotics.* 6: 19.
- R Development Core Team. 2015. *R: a language and environment for statistical computing computer program, version.* R Foundation for Statistical Computing, Vienna, Austria.
- Riedl, H. 1980. The importance of pheromone trap density and trap maintenance for the development of standardized monitoring procedures for the codling moth (Lepidoptera, Tortricidae). *Can. Entomol.* 112: 655–663.
- Riedl, H., B. A. Croft, and A. J. Howitt. 1976. Forecasting codling moth phenology based on pheromone trap catches and physiological-time models. *Can. Entomol.* 108: 449–460.
- Riedl, H., S. A. Hoying, W. W. Barnett, and J. E. Detar. 1979. Relationship of within-tree placement of the pheromone trap to codling moth (Lepidoptera, Olethreutidae) catches. *Environ. Entomol.* 8: 765–769.
- Thomson, D., J. Brunner, L. Gut, G. Judd, and A. Knight. 2001. Ten years implementing codling moth mating disruption in the orchards of Washington and British Columbia: starting right and managing for success. *IOBC/WPRS Bull.* 24: 23–30.
- van der Kooij, C. J., D. G. Stavenga, K. Arikawa, G. Belušič, and A. Kelber. 2021. Evolution of insect color vision: from spectral sensitivity to visual ecology. *Annu. Rev. Entomol.* 66: 435–461.
- Vincent, C., M. Mailloux, E. A. C. Hagley, W. H. Reissig, W. M. Coli, and T. A. Hosmer. 1990. Monitoring the codling moth (Lepidoptera, Olethreutidae) and the oblique-banded leafroller (Lepidoptera, Tortricidae) with sticky and nonsticky traps. *J. Econ. Entomol.* 83: 434–440.
- Zhu, S. M., E. Malmqvist, W. S. Li, S. Jansson, Y. Y. Li, Z. Duan, K. Svanberg, H. Q. Feng, Z. W. Song, G. Y. Zhao, *et al.* 2017. Insect abundance over Chinese rice fields in relation to environmental parameters, studied with a polarization-sensitive CW near-IR lidar system. *Appl. Phys. B Lasers Opt.* 123: 1–11.