

# Lavender Essential Oil Inhalation Improves Attentional Shifting and Accuracy: Evidence from Dynamic Changes of Cognitive Flexibility and Power Spectral Density of Electroencephalogram Signals

## Abstract

**Background:** Cognitive flexibility, a vital component of executive function, entails the utilization of extended brain networks. Olfactory stimulation has been shown to influence various brain functions, particularly cognitive performance. **Method:** To investigate aroma inhalation's effects on brain activity dynamics associated with cognitive flexibility, 20 healthy adults were recruited to complete a set-shifting task during two experimental conditions: no aroma stimuli vs. lavender essential oil inhalation. Using Thomson's multitaper approach, the normalized power spectral density (NPSD) was assessed for five frequency bands. **Results:** Findings confirm that aroma inhalation significantly affects behavioral indices (i.e., reaction time (RT) and response accuracy) and electroencephalogram (EEG) signatures, especially in the frontal lobe. Participants showed a tremendous increase in theta and alpha NPSD, associated with relaxation, along with beta NPSD, associated with clear and fast thinking after inhaling the aroma. NPSD of the delta band, an indicator of the unconscious mind, significantly decreased when stimulated with lavender essential oil. Further, participants exhibited shorter RT and more accurate responses following aroma inhalation. **Conclusion:** Our findings revealed significant changes in oscillatory power and behavioral performance after aroma inhalation, providing neural evidence that olfactory stimulation with lavender essential oil may facilitate cognitive flexibility.

**Keywords:** Cognitive flexibility, electroencephalogram, lavender essential oil, power spectral density, task-switching paradigm

Submitted: 26-Nov-2023

Revised: 09-Jan-2024

Accepted: 30-Jan-2024

Published: 18-Apr-2024

## Introduction

Aromatherapy involves applying extracted oils from plants through inhalation or external employment to treat physical and mental illnesses.<sup>[1]</sup> Its efficacy has been recognized since ancient times, such that aromatic baths and massages were used as treatment approaches.<sup>[2]</sup> Numerous studies have demonstrated that aromas significantly affect brain activity and physiological responses. For instance, rosemary fragrance has been shown to improve executive functions such as working memory and cognitive flexibility.<sup>[3]</sup> Essential oils have also shown positive effects in animals, including antidepressant demonstrations following the exposure of rodents to green tea.<sup>[4]</sup>

Lavender oil stands out among the various types of essential oils,<sup>[5]</sup> having beneficial

effects on brain activity and cognitive functions.<sup>[6]</sup> Inhaling lavender oil before bedtime has been found to effectively reduce trait anxiety levels in patients treated with chemotherapy<sup>[7]</sup> and prevent depression in the postpartum period.<sup>[8]</sup> Another study indicated that lavender oil has a positive impact on sleep electroencephalogram (EEG) patterns and the occurrence of slow-wave sleep, ultimately leading to an improvement in the overall quality of sleep.<sup>[9]</sup> Furthermore, a comprehensive analysis demonstrated that lavender essential oil inhalation yields favorable outcomes in terms of cognitive enhancement, specifically through reduced arousal levels and heightened sustained attention.<sup>[10]</sup>

Findings have illustrated that pleasant and unpleasant smells influence different brain rhythms and EEG spectrum values. A study

Reyhaneh Afghan<sup>1</sup>,  
Soomaayeh  
Heysieattalab<sup>2</sup>,  
Hamid Soltani  
Zangbar<sup>3</sup>, Abbas  
Ebrahimi-Kalan<sup>3</sup>,  
Tohid  
Jafari-Koshki<sup>4</sup>,  
Nasser  
Samadzadehghdam<sup>1</sup>

<sup>1</sup>Department of Biomedical Engineering, Faculty of Advanced Medical Sciences, Tabriz University of Medical Sciences, Tabriz, Iran,

<sup>2</sup>Department of Cognitive Neuroscience, University of Tabriz, Tabriz, Iran,

<sup>3</sup>Department of Neurosciences and Cognition, Faculty of Advanced Medical Sciences, Tabriz University of Medical Sciences, Tabriz, Iran,

<sup>4</sup>Molecular Medicine Research Center, Department of Statistics and Epidemiology, Faculty of Health, Tabriz University of Medical Sciences, Tabriz, Iran

## Address for correspondence:

Dr. Nasser Samadzadehghdam,  
Department of Biomedical Engineering, Faculty of Advanced Medical Sciences, Tabriz University of Medical Sciences, Tabriz, Iran.

E-mail: nsamadzadeh\_a@yahoo.com

## Access this article online

Website: [www.jmssjournal.net](http://www.jmssjournal.net)

DOI: 10.4103/jmss.jmss\_57\_23

## Quick Response Code:



This is an open access journal, and articles are distributed under the terms of the Creative Commons Attribution-NonCommercial-ShareAlike 4.0 License, which allows others to remix, tweak, and build upon the work non-commercially, as long as appropriate credit is given and the new creations are licensed under the identical terms.

For reprints contact: WKHLRPMedknow\_reprints@wolterskluwer.com

**How to cite this article:** Afghan R, Heysieattalab S, Soltani Zangbar H, Ebrahimi-Kalan A, Jafari-Koshki T, Samadzadehghdam N. Lavender essential oil inhalation improves attentional shifting and accuracy: Evidence from dynamic changes of cognitive flexibility and power spectral density of electroencephalogram signals. *J Med Signals Sens* 2024;14:12.

has shown that exposure to pleasant aromas can elicit positive emotions in the left frontal brain region, while exposure to unpleasant ones activates negative emotions in the bilateral frontal region and other brain areas.<sup>[11]</sup> The outcomes of another study revealed that directed attention significantly influences the perception of olfactory stimuli, particularly plant essential oils, as evidenced by distinct alterations in EEG characteristics.<sup>[12]</sup> Three frequency bands, namely, theta, alpha, and gamma, are involved in olfactory processing, and inhaling the least liked fragrance led to increased values of these frequency bands in the frontal and central brain regions compared to the most liked fragrance.<sup>[13]</sup>

Recent findings showed that exposure to various inhaling conditions directly impacts cognitive abilities.<sup>[14]</sup> For instance, there is a significant correlation between the cognitive processing speed, as measured by the letter-digit substitution test, and odor identification scores derived from the Scandinavian odor-identification test.<sup>[15]</sup> Specifically, studies have reported significant positive associations between olfactory function and cognitive flexibility.<sup>[16]</sup> Cognitive flexibility, a vital component of executive functions, refers to the ability to shift between different tasks and mental sets to adapt to a continuously changing environment.<sup>[17]</sup> In a study involving healthy participants, there was a significant correlation between olfactory performance (using the “Sniffin’ Sticks Screening 12” test) and set-shifting, as measured by the trail-making test A/B (TMT-A/B).<sup>[18]</sup>

Despite the possible impact of aromatherapy on cognitive performance, there is still some controversy in these findings. For instance, a review of aromatherapy for stress management found limited evidence despite indications that it reduces stress.<sup>[19]</sup> Furthermore, most of these studies focused on the brain at the resting state. The present study aims to examine the impact of aromatherapy on brain functions and cognitive flexibility during a specific task, highlighting its novelty and contribution to the existing literature. Given the crucial role of olfactory stimuli in cognitive function and their direct impact on the nervous system and prefrontal cortex, we expected to see a relationship between neural oscillations power and aroma inhalation while performing different switching and nonswitching mental tasks. We evaluate the cognitive flexibility of twenty healthy individuals using normalized power spectral density (NPSD) and behavioral performance differences following olfactory stimulation. The findings point to more efficient brain function for cognitive flexibility. Aromatherapy presents an effective alternative for increasing cognitive flexibility in individuals engaged in mental activities who may not have sufficient time for exercise or require immediate cognitive flexibility.

The remaining sections of this paper are structured as follows: Section 2 will provide a brief overview of the

aroma inhalation effects on cognitive functions and brain activity. In section 3, we will detail the experimental materials as well as the analysis methods, including computation of NPSD by Thomson’s multitaper approach and statistical analysis. The findings and interpretations will be presented in sections 4 and 5, respectively. Lastly, section 6 will discuss the conclusions drawn from this study.

## Literature review

Previous studies that examined the effect of aroma inhalation on neural activity reported significant changes in brain rhythms and cognitive performance. Notably, an increase in the spectral power of relatively high-frequency EEG components (11–25 Hz) suggests the activation of cognitive mechanisms. Conversely, a reduction in the spectral power of low-frequency EEG components was observed (6–11 Hz), which could be attributed to the absence of specific tasks that actively engage mechanisms of selective attention and memory.<sup>[12]</sup> Seo *et al.* found that binasal inhalation of *Abies koreana* (AEO) increases the absolute alpha value in the left frontal and right parietal regions and also the fast alpha value in the right parietal regions, indicating enhanced relaxation. In contrast, uninasal inhalation of AEO decreased the absolute beta and theta values in the right frontal and left and right parietal regions, indicating enhanced alertness and attention.<sup>[20]</sup>

Research has revealed that there are links between olfactory ability and both cognitive functions and behavioral measures. In a study on the elderly, olfactory exposure to lavender oil was examined for its impact on cognitive functions (measured by the blessed orientation memory concentration test) and daytime sleepiness (measured by the Epworth Sleepiness Scale). The findings demonstrated that using lavender oil reduced daytime sleepiness and significantly improved cognitive function in older adults.<sup>[21]</sup> Additionally, olfactory dysfunction has been widely recognized as a prominent predictor of various neurodegenerative disorders.<sup>[22]</sup> In individuals with Alzheimer’s disease, using the university of pennsylvania smell identification test and the odor memory test, Ward *et al.* proposed that olfaction is a strong predictor of memory recall and changes in odor-induced brain activity and may represent an early functional brain marker for cognitive decline in these population.<sup>[23]</sup>

## Subjects and Methods

### Experimental procedure

Twenty people aged 22–42 participated in this study, comprising eight females ( $M = 27.625$ , standard deviation [SD] = 4.688) and 12 males ( $M = 29.5$ ,  $SD = 6.557$ ). All participants had normal or corrected-to-normal vision and reported no odor allergies or COVID-19 history in the past 6 months since this virus can cause olfactory dysfunction.<sup>[24]</sup> Participants were asked

not to drink coffee or consume energy drinks on the day of the experimental session. Before the experiment, they were also asked to maintain their usual daily activity and sleep rhythms. The participants were given an oral description of the experimental protocol, including information about recording their brain activity. Following this, they provided their informed consent by signing a document approved by the Ethics Committee of Tabriz University of Medical Sciences.

The participants were comfortably seated in an electrically-shielded room, approximately 80 cm from a computer screen. Following a brief overview of the experiment, an EEG cap was affixed to their heads and they were provided with instructions to optimize task performance and minimize EEG artifacts during data acquisition. Participants then completed a practice block of the task to ensure comprehension of the instructions. Next, participants completed a task-switching paradigm using MATLAB (R2010b, The MathWorks, Inc., Natick, MA, USA)<sup>[25]</sup> while their brain responses were recorded. After this task, participants inhaled lavender essential oil as an olfactory stimulus. We provided the bottle of lavender essential oil (manufactured by atre tabib perfumery company, 4 g) near the subject's nose and asked them to inhale it five times by taking deep breaths before repeating the procedure.

We measured reaction time (RT) and response accuracy to evaluate the impact of aroma inhalation on subjects' behavioral performance. RT is the duration between stimulus presentation and the subject's response. Any responses that exceeded 1500 ms were excluded from the analysis.

### Task-switching paradigm

Task-switching paradigm is a common method to investigate cognitive flexibility since it encompasses various cognitive processes, including perceiving and recognizing stimuli, updating task sets, reallocating attention, and detecting and monitoring response conflicts.<sup>[26-28]</sup> During task-switching experiments, participants are directed to perform two distinct tasks: Task A and task B. In single blocks, only one task is presented exclusively, while in mixed block, both tasks are performed following a prespecified task sequence (e.g., AABBAABB...). As a consequence, the combination of tasks leads to switching between tasks or repeating the same task in consecutive trials. In this paradigm, two types of performance effects can be evaluated. The first is mixing effects, which compares the average performance in repeated tasks of mixed block to that of single-task blocks. The second is switch effects, which compares performance between task switch trials and task repetition trials within mixed block.<sup>[29,30]</sup> Therefore, the current study adopted this particular cognitive task.

The visual stimuli in this task consisted of a white digit presented on a black background and enclosed by either a

solid or dashed square. The task comprised three blocks: Two single blocks and one mixed block. In the first single block, the square surrounding the digit was solid and participants were required to indicate whether the digit was more or <5 (excluding the digit five). Responses were made using the left key for numbers <5 and the right key for numbers >5. The second single block involved a dashed square and required participants to indicate whether the digit was odd or even, with the left and right keys corresponding to odd and even numbers, respectively. Each of the single blocks consisted of 64 trials. The mixed block comprised 256 trials, divided into four blocks of 64 trials each, and required participants to switch between the less/more and odd/even tasks. Participants were instructed to respond as quickly and accurately as possible, using the index finger of both hands to press one of the left or right keys. The digit was displayed on the screen for 1500 ms and participants were expected to respond within this period. The subsequent trial began 500 ms after the previous one, with a 2-min break provided between each block. The sequence of tasks in the mixed block is illustrated in Figure 1.

### Electroencephalographic recording

EEG activity was recorded in the central laboratory of Tabriz University. Continuous EEG signals were recorded on 64-channel with waveguard™ cap (ANT Neuro, Enschede, Netherland), configured to 10-10 international systems. All signals were referenced to the mean activity of two mastoids and digitized at a rate of 1000 Hz. Electrode impedance was kept below 10 KΩ.

After performing the task-switching paradigm, participants were asked to inhale the lavender oil as odor stimuli five times with their maximum breathing capacity. Then, the task-switching paradigm was repeated by subjects.

### Electroencephalogram data preprocessing

EEGLAB open-source toolbox was used to preprocess EEG data.<sup>[31]</sup> Initially, EEG signals were re-referenced with average reference and passed through a bandpass filter from 0.5 Hz to 45 Hz. Independent component analysis (ICA) was performed to remove artifacts such as eyeblinks and muscle artifacts. Then, data was divided into segments of 0–1500 ms from stimuli presentation. A prestimulus period of 200 ms was subtracted as a baseline. Only the behavioral and EEG data corresponding to correct responses were analyzed.

### Power spectral density analysis

The data was processed in MATLAB (version R2022b). In the present study, we focused on analyzing the prefrontal and frontal regions of the brain due to the evident impact of olfactory stimulation and cognitive flexibility procedure on these areas.<sup>[27,32]</sup> The following are the electrodes that were studied: FP1, FPz, FP2, F7, F3, Fz, F4, F8, FC5, FC1, FC2, FC6, AF7, AF3, AF4, AF8, F5, F1, F2, F6, FC3, FCz, FC4, FT7, FT8. Power spectral density (PSD)

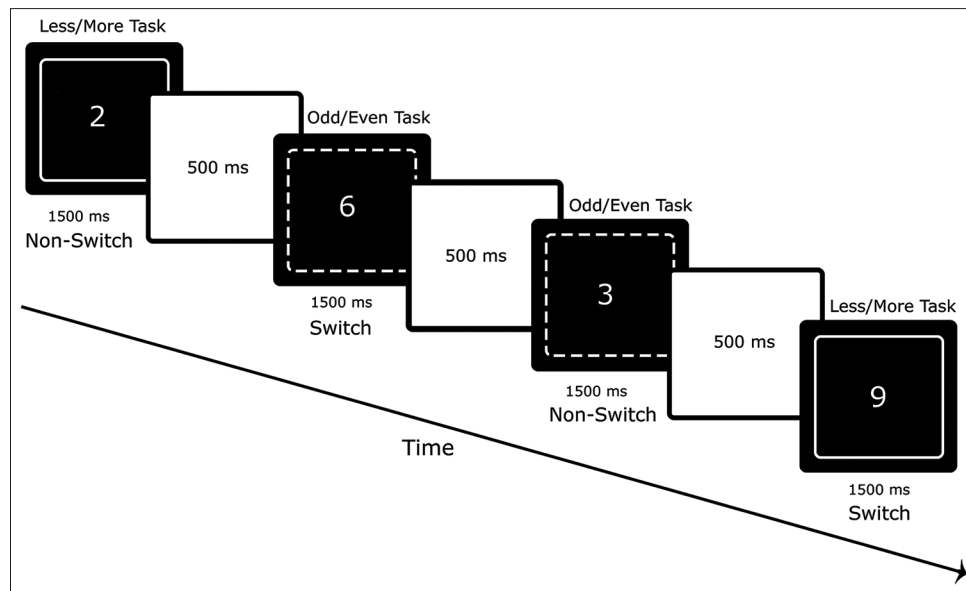

Figure 1: The sequence of tasks in a mixed block

of the signals recorded by these electrodes was estimated for five frequency bands (Delta = 1–4 Hz, theta = 4–8 Hz, alpha = 8–13 Hz, beta = 13–30 Hz, gamma = 30–45 Hz) using Thomson's multitaper approach.<sup>[33]</sup> In this method, several different windows or tapers from the family of discrete prolate spheroidal (slepian) sequences are chosen. The key features of these tapers are orthogonality and time-frequency concentration, making the multitaper a well-known method in signal processing.<sup>[34]</sup> Each taper is applied to the whole data and a periodogram is calculated by fast fourier transform. After that, the periodograms are averaged to produce the multitaper PSD estimate. The area under the curve is calculated by integrating PSD in the five frequency bands corresponding to delta, theta, alpha, beta, and gamma power. Finally, these values were normalized and considered as NPSD.

### Statistical analysis

To investigate the mixing and switch effects, two-way repeated measures analysis of variance (ANOVA) was conducted on the values associated with NPSD in five frequency bands, RT, and response accuracy. ANOVA is a statistical tool that is widely employed in psychological experiments and compares the variances among the means of different groups.<sup>[35]</sup> The normality of residual values was checked using the Shapiro–Wilk test. We conducted 2 (condition: Before and after aroma inhalation) by 3 (block: less/more, odd/even, and mixed) repeated measures ANOVA to investigate the mixing effects. In addition, the switch effects were analyzed by conducting 2 (condition: Before and after aroma inhalation) by 2 (trial: Switch and nonswitch) repeated measures ANOVA. Note that in our model always the assumption of sphericity was met. The ANOVA outcomes are reported through F-statistics, degree of freedom (df),  $P$  value, and effect size ( $\eta_p^2$ ). F-statistics is the ratio of two variances and is denoted by  $F$  (df, n), where n represents the

sample size. Also, the correlations between RT and response accuracy before and after aroma inhalation were examined by Spearman's correlation coefficients. The statistical analyses were performed using IBM SPSS software (IBM Corp. Released 2020. IBM SPSS Statistics for Windows, Version 27.0. Armonk, NY: IBM Corp) and results with  $P < 0.05$  were considered statistically significant.

## Results

The results of mixing and switch effects are presented separately for both EEG data and behavioral performance.

### Electroencephalogram data

#### Mixing effects

First of all, the values associated with NPSD in the delta, theta, alpha, beta, and gamma frequency bands were averaged across the 25 electrodes to investigate the overall changes in the frontal region. The repeated measure ANOVA revealed a significant effect of condition in all frequency bands. Figure 2 represents the average values of NPSD in the frequency bands across tasks and conditions. After inhaling lavender essential oil, delta NPSD significantly decreased in the prefrontal and frontal brain areas ( $F[1,19] = 14.701$ ,  $P = 0.001$ ,  $\eta_p^2 = 0.436$ ). On the other hand, there was a significant increase in the theta NPSD in the prefrontal and frontal regions of the brain after aroma stimulation ( $F[1,19] = 10.995$ ,  $P = 0.004$ ,  $\eta_p^2 = 0.367$ ). Additionally, inhaling lavender essential oils significantly increased alpha NPSD across the prefrontal and frontal brain areas ( $F[1,19] = 30.211$ ,  $P < 0.001$ ,  $\eta_p^2 = 0.614$ ). Beta NPSD also increased considerably in the frontal lobe after aroma inhalation ( $F[1,19] = 8.275$ ,  $P = 0.01$ ,  $\eta_p^2 = 0.303$ ). Gamma band did not represent significant changes for different tasks and conditions ( $F[1,19] = 0.113$ ,  $P = 0.74$ ,  $\eta_p^2 = 0.006$ ).



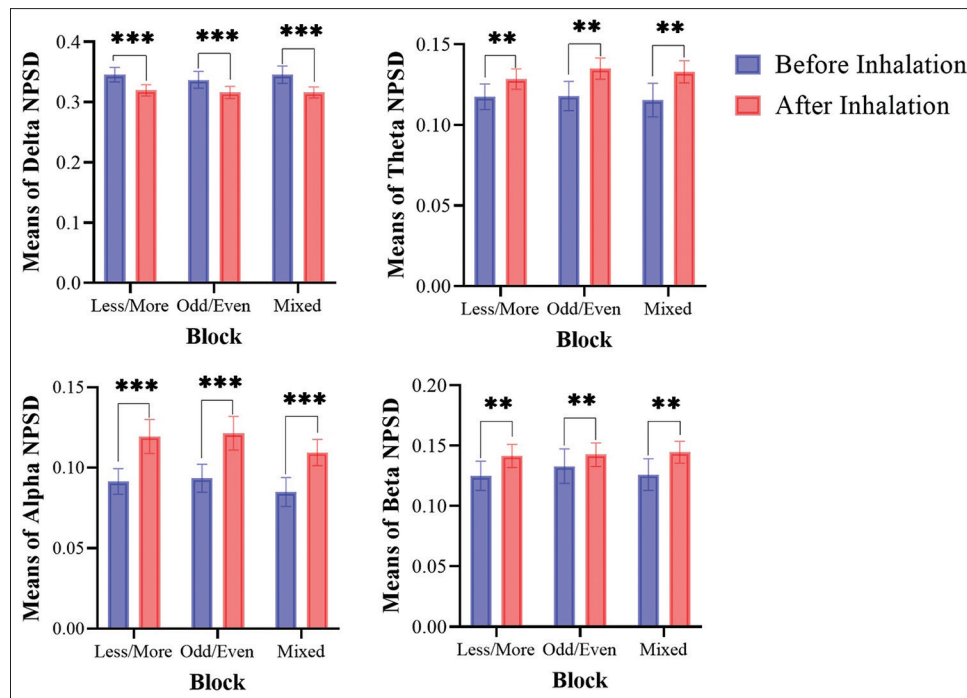

Figure 2: Mean of normalized power spectral density in frequency bands across conditions and tasks for the mixing effects (\*\* $P < 0.01$ , \*\*\* $P < 0.001$ ). NPSD: Normalized power spectral density

Table 1 illustrates detailed information about ANOVA results in relation to each electrode and frequency band.

### Switch effects

In the switch and nonswitch trials of the mixed block, as shown in Figure 3, there was a noticeable shift in the mean NPSD of selected electrodes across the delta, theta, alpha, and beta frequency bands after inhalation of lavender essential oil. The results of the repeated measures ANOVA indicated that the inhalation of lavender essential oil resulted in a significant decrease in delta NPSD in the prefrontal and frontal regions of the brain ( $F[1,19] = 11.68$ ,  $P = 0.003$ ,  $\eta_p^2 = 0.381$ ). Conversely, theta NPSD significantly increased in the prefrontal and frontal brain areas after inhaling lavender essential oil ( $F[1,19] = 7.268$ ,  $P = 0.014$ ,  $\eta_p^2 = 0.277$ ). Furthermore, a significant increase in the alpha NPSD was observed in the prefrontal and frontal regions of the brain following the inhalation of the aroma ( $F[1,19] = 26.278$ ,  $P \leq 0.001$ ,  $\eta_p^2 = 0.58$ ). Beta NPSD also increased considerably in the frontal lobe after aroma inhalation ( $F[1,19] = 6.553$ ,  $P = 0.019$ ,  $\eta_p^2 = 0.256$ ). However, no significant changes were observed in gamma power after inhaling the aroma ( $F[1,19] = 0.534$ ,  $P = 0.474$ ,  $\eta_p^2 = 0.027$ ). Table 2 provides detailed information about ANOVA results in relation to each electrode and frequency band.

### Behavioral data

#### Mixing effects

Response accuracy and RT were measured to investigate the effect of aroma inhalation on cognitive flexibility.

Figure 4a shows both response accuracy and RT for each block and condition. The results of repeated measures ANOVA revealed that subjects responded more accurately after inhaling lavender essential oil ( $F[1,19] = 32.265$ ,  $P \leq 0.001$ ,  $\eta_p^2 = 0.629$ ). In addition, RTs following the aroma inhalation were significantly shorter ( $F[1,19] = 31.168$ ,  $P \leq 0.001$ ,  $\eta_p^2 = 0.21$ ).

#### Switch effects

The repeated measures ANOVA revealed that subjects responded more accurately in both switch and nonswitch trials of mixed block after inhaling lavender essential oil ( $F[1,19] = 24.246$ ,  $P \leq 0.001$ ,  $\eta_p^2 = 0.561$ ). In addition, RTs following the aroma inhalation were significantly shorter in switch and nonswitch trials ( $F[1,19] = 43.566$ ,  $P \leq 0.001$ ,  $\eta_p^2 = 0.696$ ). Figure 4b shows both response accuracy and RT for switch effects across conditions.

#### Correlation

Spearman's correlation coefficients suggested that there is a significantly inverse association between RT and response accuracy in odd/even task ( $r_s = -0.377$ ,  $P = 0.016$ ), switch trials of mixed block ( $r_s = -0.568$ ,  $P \leq 0.001$ ), and nonswitch trials of mixed block ( $r_s = -0.369$ ,  $P = 0.019$ ). However, the correlation between RT and response accuracy in less/more task was not significant ( $r_s = -0.93$ ,  $P = 0.56$ ). Figure 5 depicts that as RT decreased after aroma inhalation, the number of correct responses increased. In addition, the dispersion of correct responses (indicated by red circles) decreases across all tasks following olfactory stimulation, showing more accurate responses by participants. Also,

**Table 1: Repeated measures analysis of variance results for the mean of normalized power spectral density associated with mixing effects for each electrode**

Electrodes	Delta			Theta			Alpha			Beta		
	<i>F</i> (1,19)	<i>P</i>	$\eta_p^2$	<i>F</i> (1,19)	<i>P</i>	$\eta_p^2$	<i>F</i> (1,19)	<i>P</i>	$\eta_p^2$	<i>F</i> (1,19)	<i>P</i>	$\eta_p^2$
FP1	17.083	<0.001	0.473	38.214	<0.001	0.668	35.238	<0.001	0.65	6.011	0.024	0.24
FPz	9.919	0.005	0.343	29.811	<0.001	0.611	24.985	<0.001	0.568	3.151	0.092	0.142
FP2	8.479	0.009	0.309	9.987	0.005	0.345	24.129	<0.001	0.559	1.433	0.246	0.07
F7	2.646	0.12	0.122	7.691	0.012	0.288	20.671	<0.001	0.521	0.234	0.634	0.012
F3	9.784	0.006	0.34	4.056	0.058	0.176	19.333	<0.001	0.504	3.984	0.06	0.173
Fz	14.804	0.001	0.438	4.75	0.042	0.2	21.403	<0.001	0.53	8.438	0.009	0.308
F4	8.99	0.007	0.321	4.875	0.04	0.204	19.934	<0.001	0.512	5.457	0.031	0.223
F8	3.777	0.067	0.166	7.013	0.016	0.27	16.871	<0.001	0.47	0.962	0.339	0.048
FC5	4.623	0.045	0.196	5.156	0.035	0.213	15.336	<0.001	0.447	3.465	0.078	0.154
FC1	12.836	0.002	0.403	2.36	0.141	0.111	15.021	0.001	0.442	11.401	0.003	0.375
FC2	13.882	0.001	0.422	2.301	0.146	0.108	19.474	<0.001	0.506	9.228	0.007	0.327
FC6	5.852	0.026	0.235	12.449	0.002	0.396	25.156	<0.001	0.57	2.701	0.117	0.124
AF7	1.723	0.205	0.083	22.962	<0.001	0.547	25.294	<0.001	0.571	0.054	0.818	0.003
AF3	12.985	0.002	0.406	12.214	0.002	0.391	24.498	<0.001	0.563	2.524	0.129	0.117
AF4	16.167	<0.001	0.46	12.062	0.003	0.388	20.792	<0.001	0.523	10.224	0.005	0.35
AF8	6.398	0.02	0.252	9.744	0.006	0.339	21.201	<0.001	0.527	1.568	0.226	0.076
F5	15.575	<0.001	0.45	17.545	<0.001	0.48	30.473	<0.001	0.616	9.714	0.006	0.338
F1	14.48	0.001	0.433	4.586	0.045	0.194	26.049	<0.001	0.578	8.903	0.008	0.319
F2	12.647	0.002	0.4	6.173	0.022	0.245	24.64	<0.001	0.565	7.017	0.016	0.27
F6	7.73	0.012	0.289	11.199	0.003	0.371	29.328	<0.001	0.607	4.39	0.05	0.188
FC3	27.61	<0.001	0.592	8.687	0.008	0.314	31.839	<0.001	0.626	22.727	<0.001	0.545
FCz	20.021	<0.001	0.513	3.317	0.084	0.149	20.962	<0.001	0.525	22.4	<0.001	0.541
FC4	9.056	0.007	0.323	3.612	0.073	0.16	18.347	<0.001	0.491	5.191	0.034	0.215
FT7	7.418	0.013	0.281	6.073	0.023	0.242	12.857	0.002	0.404	6.021	0.024	0.241
FT8	1.967	0.177	0.094	6.981	0.016	0.269	13.277	0.002	0.411	1.221	0.283	0.06

there is a leftward shift in RT, indicating a decrease in the amount of time required to complete the task.

## Discussion

In this study, the psychophysiological responses of olfactory stimulation using aroma oil were examined in healthy adults. We investigated the changes in cognitive flexibility indexes associated with task-switching performance after inhaling lavender essential oil, regarding NPSD and behavioral measurements. Task-switching paradigm can assess both the mixing effects (i.e., the difference in performance between single and mixed blocks) and the switch effects (i.e., the difference in performance between switch and nonswitch trials in mixed block).<sup>[29]</sup> These effects are based on different concepts. The mixing effects are believed to indicate the difficulty of keeping task sets in working memory, while the switch effects reflect the cognitive flexibility in task sets.<sup>[36]</sup> Therefore, we focused on switch effects in this study. The results revealed considerable changes in frequency bands, shorter RTs, and higher accuracy after participants inhaled lavender essential oil.

The impact of olfaction on mood, cognition, behavior, and emotions has been well documented in previous research.<sup>[6,37]</sup> The current study's findings on the positive

effects of lavender on cognitive function align with previous studies, confirming improvements in cognitive function following lavender oil inhalation alone or in combination with other essential oils. As an example, a study suggested that lavender essential oil positively impacts cognitive performance during a working memory task under acute stress conditions.<sup>[38]</sup>

The analysis of EEG alterations in the current study was centered on the prefrontal and frontal cortex, a region of the brain mainly associated with cognitive processing, flexibility, and olfaction. After stimulation with lavender essential oil, the EEG results indicated significant increases in theta and alpha, which are physiological markers of relaxation.<sup>[39]</sup> Similarly, there was a significant increase in beta, an indicator of brain activity.<sup>[40]</sup> Based on the spectral changes of rhythms during olfactory stimulation, our findings suggest that states of relaxation and concentration can co-occur to some extent, consistent with previous studies.<sup>[41]</sup> Furthermore, inhaling the aroma significantly decreased delta waves, commonly associated with the unconscious mind.<sup>[42]</sup>

Out of the five frequency bands, the alpha band exhibits the highest number of significant features during all tasks and conditions. Our study found that NPSD of the alpha wave was significantly higher in the frontal and prefrontal

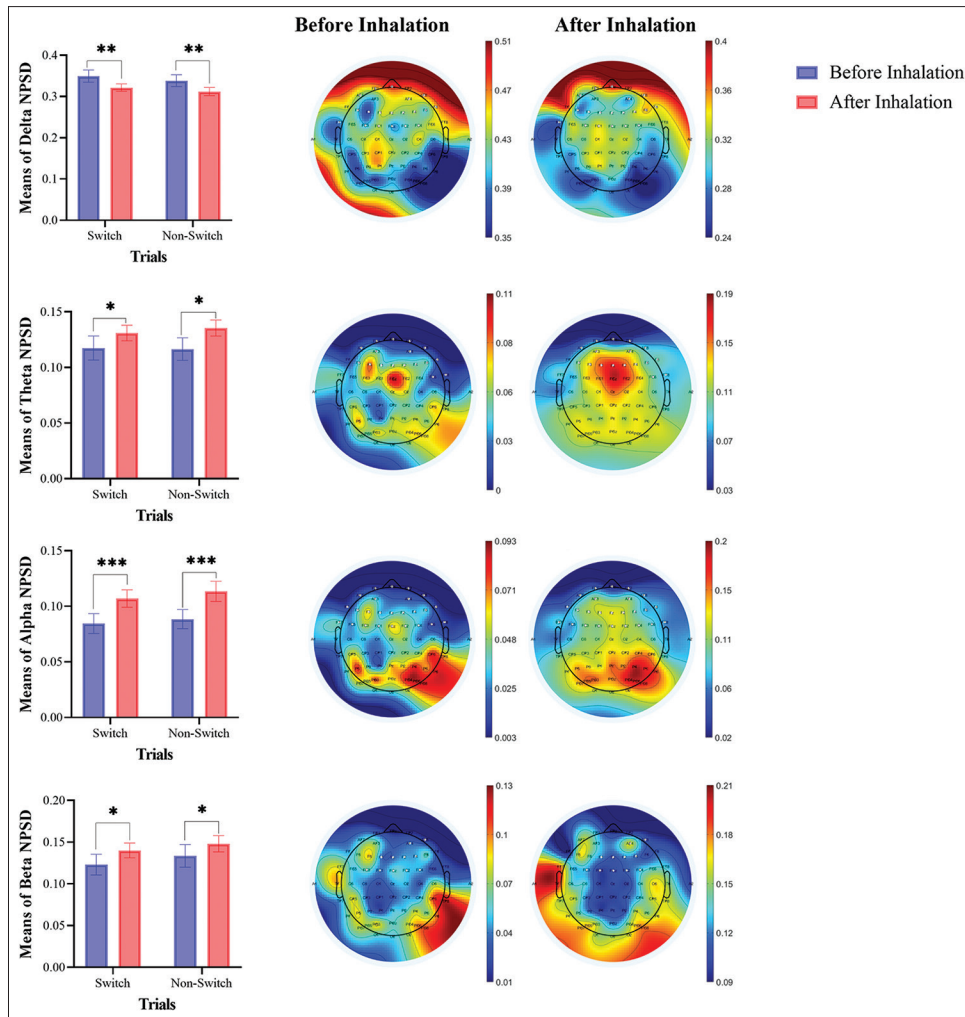

**Figure 3: Mean of normalized power spectral density and scalp topography maps of frequency bands across conditions for the switch effects (\* $P < 0.05$ , \*\* $P < 0.01$ , \*\*\* $P < 0.001$ ). White circles show the statistically significant electrodes. NPSD: Normalized power spectral density**

regions of the brain after participants inhaled lavender essential oil. Alpha waves have been associated with reduced mental stress, increased relaxation, and improved memory in previous findings.<sup>[43,44]</sup> As an example, research investigating EEG power changes has demonstrated that aroma inhalation can significantly increase alpha waves, reducing academic stress among students.<sup>[45]</sup> Increased alpha activity indicates active preparation of the cortical system for complex information processing, thus enhancing the state of readiness to perform a task.<sup>[46]</sup> Therefore, higher alpha activity is associated with favorable behavioral outcomes, including faster and more precise responses as well as improved performance on cognitive tasks that require focused attention and target detection.<sup>[47-49]</sup> Our study discloses that the overall increase in alpha activity is consistent with prior research, demonstrating that concentration and relaxation are possible during cognitive tasks. Apart from alpha waves, a noteworthy increase in NPSD of theta waves was also detected in the current study, indicative of a relaxation state. These findings are in line with a previous study that documented a significant

rise in alpha and theta waves following exposure to lavender essential oil, indicating a stress reduction.<sup>[50]</sup> Our findings suggest that the inhalation of lavender essential oil may promote cognitive flexibility by enabling individuals to perform cognitive tasks in a focused and relaxed manner due to the apparent connection between them and the aforementioned frequency bands.

Besides theta and alpha bands, herein, we showed that NPSD of the beta band significantly increased following aroma inhalation. This finding aligns with previous research indicating that beta waves originating from the frontal cortex primarily reflect cognitive processes such as stimulus evaluation and decision-making,<sup>[51]</sup> concerning associated attention and concentration.<sup>[52]</sup> In line with our current findings, previous studies have also suggested a positive correlation between higher beta-wave activity and enhanced attention.<sup>[53]</sup> Our results further support this notion by demonstrating that inhaling lavender essential oil resulted in greater beta wave values, which may enhance attention and improve cognitive flexibility to a greater degree.

**Table 2: Repeated measures analysis of variance results for the mean of normalized power spectral density associated with switch effects for each electrode**

Electrodes	Delta			Theta			Alpha			Beta		
	<i>F</i> (1,19)	<i>P</i>	$\eta_p^2$	<i>F</i> (1,19)	<i>P</i>	$\eta_p^2$	<i>F</i> (1,19)	<i>P</i>	$\eta_p^2$	<i>F</i> (1,19)	<i>P</i>	$\eta_p^2$
FP1	6.318	0.021	0.25	32.713	<0.001	0.633	21.337	<0.001	0.529	2.475	0.132	0.115
FPz	6.019	0.024	0.241	18.458	<0.001	0.493	20.301	<0.001	0.517	2.194	0.155	0.104
FP2	2.097	0.164	0.099	8.361	0.009	0.306	13.22	0.002	0.41	0.329	0.573	0.017
F7	3.188	0.09	0.144	3.107	0.094	0.141	16.196	<0.001	0.46	0.518	0.48	0.027
F3	7.088	0.015	0.272	4.961	0.038	0.207	18.297	<0.001	0.491	2.435	0.135	0.114
Fz	13.356	0.002	0.413	5.472	0.03	0.224	16.849	<0.001	0.47	11.575	0.003	0.379
F4	7.952	0.011	0.295	6.04	0.024	0.241	17.509	<0.001	0.48	5.853	0.026	0.236
F8	4.537	0.046	0.193	5.311	0.033	0.218	14.212	0.001	0.428	2.009	0.173	0.096
FC5	2.678	0.118	0.124	1.249	0.278	0.062	5.781	0.027	0.233	1.119	0.303	0.056
FC1	10.837	0.004	0.363	2.226	0.152	0.105	13.563	0.002	0.417	12.776	0.002	0.402
FC2	14.222	0.001	0.428	2.132	0.161	0.101	19.251	<0.001	0.503	11.812	0.003	0.383
FC6	3.301	0.085	0.148	12.808	0.002	0.403	19.925	<0.001	0.512	0.843	0.37	0.042
AF7	4.639	0.044	0.196	15.625	<0.001	0.451	21.753	<0.001	0.534	0.678	0.421	0.034
AF3	3.259	0.087	0.146	6.845	0.017	0.265	18.557	<0.001	0.494	0.405	0.532	0.021
AF4	13.093	0.002	0.408	6.781	0.017	0.263	21.199	<0.001	0.527	8.551	0.009	0.31
AF8	9.104	0.007	0.324	10.444	0.004	0.355	26.628	<0.001	0.584	4.778	0.042	0.201
F5	7.19	0.015	0.275	7.346	0.014	0.279	14.819	0.001	0.438	3.12	0.093	0.141
F1	11.843	0.003	0.384	4.766	0.042	0.201	18.742	<0.001	0.497	8.409	0.009	0.307
F2	8.973	0.007	0.321	4.683	0.043	0.198	17.015	<0.001	0.472	5.676	0.028	0.23
F6	4.994	0.038	0.208	5.29	0.033	0.218	16.579	<0.001	0.466	3.555	0.075	0.158
FC3	18.607	<0.001	0.495	3.943	0.062	0.172	16.547	<0.001	0.465	19.921	<0.001	0.512
FCz	17.094	<0.001	0.474	3.758	0.068	0.165	22.281	<0.001	0.54	14.543	0.001	0.434
FC4	11.933	0.003	0.386	1.778	0.198	0.086	16.001	<0.001	0.457	7.525	0.013	0.284
FT7	5.027	0.037	0.209	1.266	0.275	0.062	5.909	0.025	0.237	3.172	0.091	0.143
FT8	1.67	0.212	0.081	6.158	0.023	0.245	10.661	0.004	0.359	0.916	0.351	0.046

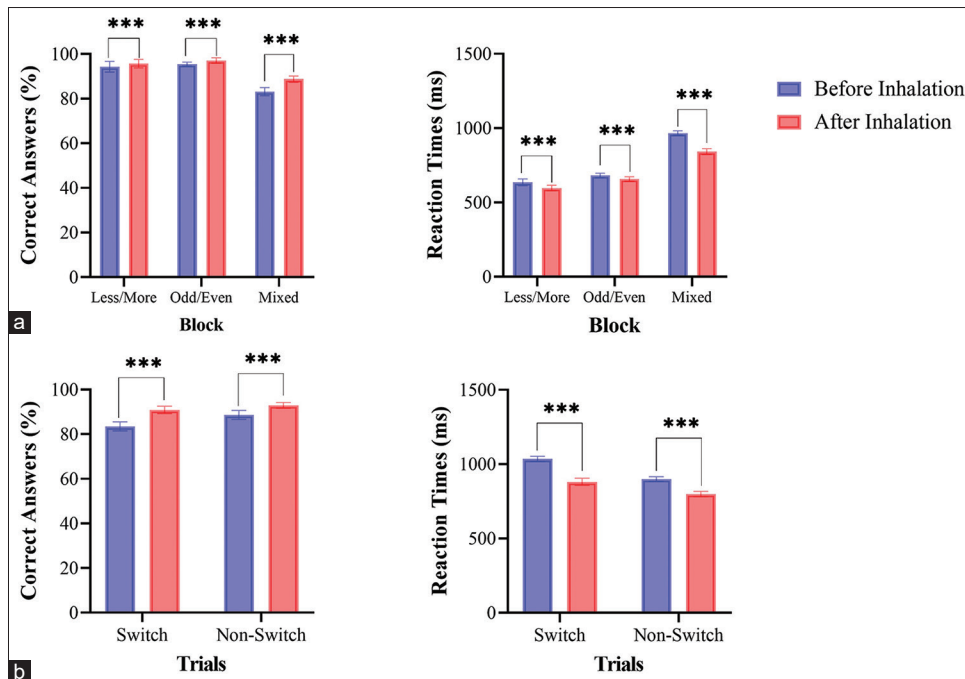

**Figure 4: Mean of response accuracy and reaction time across conditions for (a) Mixing effects and (b) Switch effects (\*\**P* < 0.001)**

In the current study, NPSD of the delta band decreased significantly after aroma inhalation. Since the delta

manifestation follows the unconscious state and typically develops through deep sleep,<sup>[44]</sup> present findings suggest



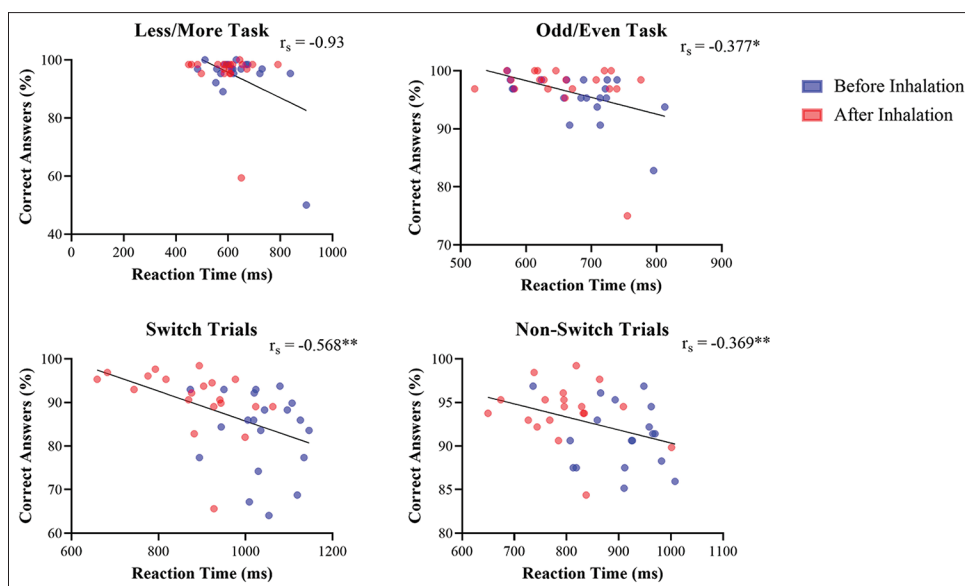

Figure 5: Correlation plots between reaction time and response accuracy across tasks and conditions (\* $P < 0.05$ , \*\* $P < 0.01$ )

that the reduction in the delta band can result in alertness and conscious processing. Some situations that elicit high stress or anxiety levels, such as public speaking, panic, and fear, significantly increase gamma band power.<sup>[54,55]</sup> However, our observation showed no significant changes in the gamma band, suggesting that participants were relaxed during the study.

The behavioral results of the current study suggest that inhaling lavender essential oil results in increased response accuracy and declined RT, meaning an enhancement in cognitive flexibility. These are along with the previous studies which reported faster RT and improved accuracy after lavender essential oil inhalation.<sup>[10]</sup>

The analysis of EEG changes and behavioral performance in the current study suggests that olfactory stimulation with lavender essential oil effectively induces psychophysiological relaxation and enhances cognitive flexibility.

## Conclusions

This study aimed to evaluate the impact of olfactory stimulation using lavender essential oil on the cognitive responses of healthy individuals. The results indicated that the stimulation led to increased stability and relaxation in the prefrontal and frontal cortex as well as enhanced brain activity and cognitive flexibility. Furthermore, the participants were able to complete the task-switching paradigm more accurately and in less time, which may be a marker for attentional increase. Therefore, we suggest that conditioning with lavender essential oil may improve students' and employees' concentration levels and cognitive flexibility and increase their efficiency. However, further research is necessary to broaden the scope of application by exploring the effects of different types of aroma stimuli

on various conditions and diseases, using other methods such as event-related potentials.

## Availability of data and materials

The datasets used and/or analyzed during the current study are available from the corresponding author on reasonable request.

## Ethics approval and consent to participate

This study was conducted in accordance with the Declaration of Helsinki, and approved by the research ethics committee of Tabriz University of Medical Sciences (Research ethics code: IR. TBZMED. REC.1401.448). Before the experiment, all the participants were provided with ethical research clearance and written informed consent.

## Acknowledgement

We express our gratitude to all of the participants who took part in this study.

## Financial support and sponsorship

The current research was conducted as a part of M.Sc. thesis, which was financially supported by Tabriz University of Medical Sciences, under the grant number of 69655.

## Conflicts of interest

There are no conflicts of interest.

## References

1. Segen C. Dictionary of Alternative Medicine. Stamford: CT Appleton and Lange; 1998.
2. Rose J. The Aromatherapy Book: Applications and Inhalations. USA: North Atlantic Books; 2013.
3. Şahin Sadık E, Saraoğlu HM, Canbaz Kabay S, Tosun M, Keskinçilic C, Akdağ G. Investigation of the effect of rosemary

- odor on mental workload using EEG: An artificial intelligence approach. *Signal Image Video Process* 2022;16:497-504.
4. Zhu WL, Shi HS, Wei YM, Wang SJ, Sun CY, Ding ZB, *et al.* Green tea polyphenols produce antidepressant-like effects in adult mice. *Pharmacol Res* 2012;65:74-80.
  5. Sattayakhom A, Wichit S, Koomhin P. The effects of essential oils on the nervous system: A scoping review. *Molecules* 2023;28:3771.
  6. Thangaleela S, Sivamaruthi BS, Kesika P, Bharathi M, Kunaviktikul W, Klunklin A, *et al.* Essential oils, phytoncides, aromachology, and aromatherapy-a review. *Appl Sci* 2022;12:4495.
  7. Ozkaraman A, Dügüm Ö, Özen Yılmaz H, Usta Yesilbalkan Ö. Aromatherapy: The effect of lavender on anxiety and sleep quality in patients treated with chemotherapy. *Clin J Oncol Nurs* 2018;22:203-10.
  8. Kianpour M, Mansouri A, Mehrabi T, Asghari G. Effect of lavender scent inhalation on prevention of stress, anxiety and depression in the postpartum period. *Iran J Nurs Midwifery Res* 2016;21:197-201.
  9. Ko LW, Su CH, Yang MH, Liu SY, Su TP. A pilot study on essential oil aroma stimulation for enhancing slow-wave EEG in sleeping brain. *Sci Rep* 2021;11:1078.
  10. Malloggi E, Menicucci D, Cesari V, Frumento S, Gemignani A, Bertoli A. Lavender aromatherapy: A systematic review from essential oil quality and administration methods to cognitive enhancing effects. *Appl Psychol Health Well Being* 2022;14:663-90.
  11. Kim YK, Watanuki S. Characteristics of electroencephalographic responses induced by a pleasant and an unpleasant odor. *J Physiol Anthropol Appl Human Sci* 2003;22:285-91.
  12. Cherninskii A, Zima I, Makarchouk NY, Piskorskaya N, Kryzhanovskii S. Modifications of EEG related to directed perception and analysis of olfactory information in humans. *Neurophysiology* 2009;41:63-70.
  13. Abbasi NI, Bose R, Bezerianos A, Thakor NV, Dragomir A. EEG-based classification of olfactory response to pleasant stimuli. *Annu Int Conf IEEE Eng Med Biol Soc* 2019;2019:5160-3.
  14. Midorikawa M, Suzuki H, Suzuki Y, Yamauchi K, Sato H, Nemoto K, *et al.* Relationships between cognitive function and odor identification, balance capability, and muscle strength in middle-aged persons with and without type 2 diabetes. *J Diabetes Res* 2021;2021:9961612.
  15. Larsson M, Nilsson LG, Olofsson JK, Nordin S. Demographic and cognitive predictors of cued odor identification: Evidence from a population-based study. *Chem Senses* 2004;29:547-54.
  16. Challakere Ramaswamy VM, Schofield PW. Olfaction and executive cognitive performance: A systematic review. *Front Psychol* 2022;13:871391.
  17. Buttelmann F, Karbach J. Development and plasticity of cognitive flexibility in early and middle childhood. *Front Psychol* 2017;8:1040.
  18. Yahiaoui Doktor M, Luck T, Riedel Heller SG, Loeffler M, Wirkner K, Engel C. Olfactory function is associated with cognitive performance: Results from the population-based life-adult-study. *Alzheimers Res Ther* 2019;11:43.
  19. Hur MH, Song JA, Lee J, Lee MS. Aromatherapy for stress reduction in healthy adults: A systematic review and meta-analysis of randomized clinical trials. *Maturitas* 2014;79:362-9.
  20. Seo M, Sowndhararajan K, Kim S. Influence of binasal and uninasal inhalations of essential oil of abies koreana twigs on electroencephalographic activity of human. *Behav Neurol* 2016;2016:9250935.
  21. Aydın Yıldırım T, Kitiş Y. The effect of aromatherapy application on cognitive functions and daytime sleepiness in older adults living in a nursing home. *Holist Nurs Pract* 2020;34:83-90.
  22. Doty RL. Olfactory dysfunction in neurodegenerative diseases: Is there a common pathological substrate? *Lancet Neurol* 2017;16:478-88.
  23. Ward AM, Calamia M, Thiemann E, Dunlap J, Tranel D. Association between olfaction and higher cortical functions in Alzheimer's disease, mild cognitive impairment, and healthy older adults. *J Clin Exp Neuropsychol* 2017;39:646-58.
  24. Gary JB, Gallagher L, Joseph PV, Reed D, Gudis DA, Overvest JB. Qualitative olfactory dysfunction and COVID-19: An evidence-based review with recommendations for the clinician. *Am J Rhinol Allergy* 2023;37:95-101.
  25. Bae S, Masaki H. Effects of acute aerobic exercise on cognitive flexibility required during task-switching paradigm. *Front Hum Neurosci* 2019;13:260.
  26. Tsai CL, Wang WL. Exercise-mode-related changes in task-switching performance in the elderly. *Front Behav Neurosci* 2015;9:56.
  27. Uddin LQ. Cognitive and behavioural flexibility: Neural mechanisms and clinical considerations. *Nat Rev Neurosci* 2021;22:167-79.
  28. Grange J, Houghton G. *Task Switching and Cognitive Control*. USA: Oxford University Press; 2014.
  29. Karbach J, Kray J. How useful is executive control training? Age differences in near and far transfer of task-switching training. *Dev Sci* 2009;12:978-90.
  30. Strobach T, Liepelt R, Schubert T, Kiesel A. Task switching: Effects of practice on switch and mixing costs. *Psychol Res* 2012;76:74-83.
  31. Delorme A, Makeig S. EEGLAB: An open source toolbox for analysis of single-trial EEG dynamics including independent component analysis. *J Neurosci Methods* 2004;134:9-21.
  32. Masuo Y, Satou T, Takemoto H, Koike K. Smell and stress response in the brain: Review of the connection between chemistry and neuropharmacology. *Molecules* 2021;26:2571.
  33. Thomson DJ. Spectrum estimation and harmonic analysis. *Proc IEEE* 1982;70:1055-96.
  34. Babadi B, Brown EN. A review of multitaper spectral analysis. *IEEE Trans Biomed Eng* 2014;61:1555-64.
  35. Counsell A, Harlow LL. Reporting practices and use of quantitative methods in Canadian journal articles in psychology. *Can Psychol* 2017;58:140-7.
  36. Rogers RD, Monsell S. Costs of a predictable switch between simple cognitive tasks. *J. Exp Psychol Gen* 1995;124:207.
  37. Holmes C, Hopkins V, Hensford C, MacLaughlin V, Wilkinson D, Rosenvinge H. Lavender oil as a treatment for agitated behaviour in severe dementia: A placebo controlled study. *Int J Geriatr Psychiatry* 2002;17:305-8.
  38. Chamine I, Oken BS. Aroma effects on physiologic and cognitive function following acute stress: A mechanism investigation. *J Altern Complement Med* 2016;22:713-21.
  39. Lagopoulos J, Xu J, Rasmussen I, Vik A, Malhi GS, Eliassen CF, *et al.* Increased theta and alpha EEG activity during nondirective meditation. *J Altern Complement Med* 2009;15:1187-92.
  40. Bos DO. EEG Based Emotion Recognition. The Influence of Visual and Auditory Stimuli. Ph.D. Thesis, Department of Computer Science, University of Twente, Enschede; 2006;Vol. 56:p. 1-17.
  41. Jiang S, Deng L, Luo H, Li X, Guo B, Jiang M, *et al.* Effect of fragrant primula flowers on physiology and psychology in

- female college students: An empirical study. *Front Psychol* 2021;12:607876.
42. Emmons WH, Simon CW. EEG, consciousness, and sleep. *Science* 1956;124:1066-9.
  43. Ismail LE, Karwowski W. Applications of EEG indices for the quantification of human cognitive performance: A systematic review and bibliometric analysis. *PLoS One* 2020;15:e0242857.
  44. Alarcao SM, Fonseca MJ. Emotions recognition using EEG signals: A survey. *IEEE Trans Affect Comput* 2017;10:374-93.
  45. Kim WJ, Kwon MH, Kwon MH, Kim JG. Effects of aroma therapy on EEG and academic stress. *Sci Emot Sensib* 2015;18:95-102.
  46. Kim SC, Lee MH, Jang C, Kwon JW, Park JW. The effect of alpha rhythm sleep on EEG activity and individuals' attention. *J Phys Ther Sci* 2013;25:1515-8.
  47. Mo J, Schroeder CE, Ding M. Attentional modulation of alpha oscillations in macaque inferotemporal cortex. *J Neurosci* 2011;31:878-82.
  48. Rajagovindan R, Ding M. From prestimulus alpha oscillation to visual-evoked response: An inverted-U function and its attentional modulation. *J Cogn Neurosci* 2011;23:1379-94.
  49. Händel BF, Haarmeier T, Jensen O. Alpha oscillations correlate with the successful inhibition of unattended stimuli. *J Cogn Neurosci* 2011;23:2494-502.
  50. Sayorwan W, Siripornpanich V, Piriyaapunyaporn T, Hongratanaworakit T, Kotchabhakdi N, Ruangrunsi N. The effects of lavender oil inhalation on emotional states, autonomic nervous system, and brain electrical activity. *J Med Assoc Thai* 2012;95:598-606.
  51. Kim D, Kim M, Kim S, Park Y, Park J, Bae K, *et al.* Understanding and Application of EEG. Seoul: Hakjisa; 2017. p. 145-50.
  52. Coben R, Linden M, Myers TE. Neurofeedback for autistic spectrum disorder: A review of the literature. *Appl Psychophysiol Biofeedback* 2010;35:83-105.
  53. Ülker B, Tabakcioğlu MB, Çizmeci H, Ayberkin D, editors. Relations of Attention and Meditation Level with Learning in Engineering Education. 9<sup>th</sup> International Conference on Electronics, Computers and Artificial Intelligence. IEEE; 2017.
  54. Amo C, de Santiago L, Barea R, López Dorado A, Boquete L. Analysis of gamma-band activity from human EEG using empirical mode decomposition. *Sensors (Basel)* 2017;17:989.
  55. Pineda-Hernández S. Playing under pressure: EEG monitoring of activation in professional tennis players. *Physiol Behav* 2022;247:113723.