

# Effects of Fear of COVID-19 on Mental Well-Being and Quality of Life among Saudi Adults: A Path Analysis

Mohsen Alyami<sup>1</sup>, Julia Vajda de Albuquerque<sup>2</sup>, Christian U. Krägeloh<sup>3</sup>, Hussain Alyami<sup>4</sup>, Marcus A. Henning<sup>2</sup>

<sup>1</sup>Department of Psychological Medicine, University of Auckland, Auckland, New Zealand, <sup>2</sup>Centre for Medical and Health Sciences Education, University of Auckland, Auckland, New Zealand, <sup>3</sup>Department of Psychology and Neuroscience, Auckland University of Technology, Auckland, New Zealand, <sup>4</sup>College of Medicine, Taif University, Taif, Saudi Arabia

## Abstract

**Background:** The coronavirus disease 2019 (COVID-19) pandemic has been very disruptive, and thus is likely to result in substantial challenges to mental health.

**Objectives:** This study aimed to investigate the effects of fear of COVID-19 on the mental well-being and quality of life among Saudi adult population and to evaluate the impact of perceived social support.

**Materials and Methods:** This cross-sectional study used an anonymous online survey, where participants were administered the Fear of COVID-19 Scale, Hospital Anxiety and Depression Scale, European Health Interview Survey-Quality of Life and Medical Outcomes Study Social Support Survey. A path analysis was used to investigate the proposed theoretical domain structure linking fear of COVID-19 with perceived social support, mental well-being and quality of life.

**Results:** A total of 1029 Saudi adults with a mean age of 33.7 years (SD 11.5) responded to the survey. Descriptive analysis showed that this sample was fearful of COVID-19, anxious and depressed but, at the same time, reported high quality of life and perceived social support scores. Path analysis indicated that increased fear of COVID-19 was directly associated with diminished mental well-being, which in turn was associated with lower quality of life. The beneficial effects of perceived social support were stronger on quality of life than on mental well-being. No direct link was found between fear of COVID-19 and quality of life.

**Conclusion:** These findings emphasize the importance of having effective social systems in place to minimize the impact of the COVID-19 pandemic on mental well-being and quality of life.

**Keywords:** COVID-19, fear, mental health, quality of life, social support, well-being

**Address for correspondence:** Mohsen Alyami, Department of Psychological Medicine, University of Auckland, Auckland, New Zealand.

E-mail: maly002@aucklanduni.ac.nz

**Submitted:** 28-Aug-2020 **Revised:** 01-Oct-2020 **Accepted:** 21-Oct-2020 **Published:** 26-Nov-2020

## INTRODUCTION

In January 2020, the World Health Organization (WHO) declared the coronavirus disease 2019 (COVID-19) outbreak an international public health emergency.<sup>[1]</sup> The global community continues to face high transmission rates

of this unpredictable, fast-spreading infectious disease that presents serious challenges to global health.<sup>[2,3]</sup> To slow the spread of the virus, overload of healthcare systems and infection-related mortality, most governments worldwide

Access this article online	
Quick Response Code:	Website: www.sjmms.net
	DOI: 10.4103/sjmms.sjmms_630_20

This is an open access journal, and articles are distributed under the terms of the Creative Commons Attribution-NonCommercial-ShareAlike 4.0 License, which allows others to remix, tweak, and build upon the work non-commercially, as long as appropriate credit is given and the new creations are licensed under the identical terms.

**For reprints contact:** WKHLRPMedknow\_reprints@wolterskluwer.com

**How to cite this article:** Alyami M, de Albuquerque JV, Krägeloh CU, Alyami H, Henning MA. Effects of fear of COVID-19 on mental well-being and quality of life among Saudi adults: A path analysis. Saudi J Med Med Sci 2021;9:24-30.

have implemented isolation, quarantine and physical and social distancing as the fundamental infection control measure.<sup>[4,5]</sup> These unpleasant and unpredictable changes bring the perception of constrained freedom, increased psychological distress and community anxiety, elevated fears and misconceptions.<sup>[5,6]</sup> These, in turn, can have a profound effect on an individual's lifestyle and social relationships.<sup>[7]</sup>

COVID-19 raises a broad range of public mental health concerns, including distress reactions (sleep disorders, anger and extreme fear), health risk behaviors (increased substance abuse, social isolation) and lowered perceived health.<sup>[2,6-9]</sup> These responses affect mental health and quality of life (QoL) at personal and population levels, possibly negatively affecting mood and cognition as well as triggering social dysfunction, mass hysteria, stigma, discrimination, xenophobia and marginalization.<sup>[10-13]</sup> Overall, COVID-19 challenges the QoL of people worldwide, exacerbating interpersonal issues and raising questions of self-acceptance, meaning in life and relationships with others.<sup>[10]</sup>

The first confirmed case in Saudi Arabia was reported on March 2, 2020.<sup>[14]</sup> Among the Gulf states, Saudi Arabia has the highest count of confirmed cases of COVID-19,<sup>[15]</sup> with more than 342,000 confirmed cases and 5185 deaths at the time of finalizing this paper.<sup>[16]</sup> This study aimed to investigate the effects of fear of COVID-19 on mental well-being and QoL among the Saudi adult general population and to evaluate the impact of perceived social support. We hypothesized that fear of COVID-19 is associated with anxiety and/or depressive symptoms, potentially explaining QoL, but perceived social support may ameliorate this impact.

## MATERIALS AND METHODS

### Participants and procedure

Participants were Saudi adults aged  $\geq 18$  years. An anonymous survey administered through Google Forms was used to collect data from participants recruited using a snowball sampling technique. Invitations to take part in the study were shared through e-mail to personal and professional contacts and posted on social media platforms (Twitter, Facebook and LinkedIn) after obtaining approval from the Research Ethics Committee of Taif University. Eligible participants were asked to share the study with their personal and professional networks. Furthermore, participants had to answer all questions to submit their responses. Participation was voluntary, and all participants provided electronic informed consent. Data collection occurred between April 11 and May 11,

2020. During this period, the daily count of confirmed cases ranged between 382 and 1966 and the total number of confirmed cases had exceeded 41,000.<sup>[16]</sup> Several precautionary measures had also been implemented including a 24-h curfew in Mecca and Medina,<sup>[17]</sup> lockdown in several cities including Riyadh, Jeddah, Taif, Tabuk, Dammam and Hofuf, as well as suspension of international and domestic air travels.<sup>[18]</sup>

### Measures

Participants provided information regarding their age, sex, marital status, education status, employment status, monthly income and region of residence. In addition, participants indicated if they, or a family member, had a COVID-19 diagnosis (yes/no).

### Fear of COVID-19

The Arabic version of the Fear of COVID-19 Scale (FCV-19S) was used to measure the fear levels of COVID-19.<sup>[19]</sup> The FCV-19S consists of seven items and is scored on a 5-point scale, ranging from 1 (strongly disagree) to 5 (strongly agree).<sup>[20]</sup> A total score is calculated by adding all item scores with a possible total score ranging from 7 to 35. Higher scores indicate higher levels of Fear of COVID-19. The original scale scores as well as scores from the Arabic version have shown robust psychometric properties.<sup>[19,20]</sup>

### Mental well-being

The Arabic version of the Hospital Anxiety and Depression Scale (HADS) was used to measure the levels of psychological distress.<sup>[21]</sup> The HADS consists of 14 items: seven items each for the anxiety (HADS-A) and depression (HADS-D) subscales. Each item is scored on a 4-point scale and item scores are summed to yield HADS-A and HADS-D total scores (range 0–21 for each subscale). In addition, an overall total score (HADS-T) is computed by adding all item scores (range 0–42). Higher scores indicate greater psychological distress.<sup>[22]</sup> The HADS has demonstrated satisfactory psychometric properties in patient groups as well as in general populations.<sup>[23,24]</sup> The Arabic version of the HADS has also shown satisfactory psychometric properties.<sup>[21]</sup>

### Quality of life

The Arabic version of the European Health Interview Survey-Quality of Life (EUROHIS-QOL 8-item index) was used to measure the QoL. The EUROHIS-QOL is a brief version derived from the WHOQOL-BREF.<sup>[25]</sup> It consists of eight items and is scored on a 5-point scale ranging from 1 (not at all/very poor/very dissatisfied) to 5 (completely/very good/very satisfied). Each domain

in the WHOQOL-BREF (social, psychological, physical and environmental) is represented by two items in the EUROHIS-QOL. An overall QoL score is computed by adding all item scores (range 8–40), with higher scores indicating better QoL.<sup>[26]</sup> The EUROHIS-QOL has shown satisfactory psychometric qualities.<sup>[26,27]</sup> Although the Arabic version of the EUROHIS-QOL has not been psychometrically tested, the Arabic version of the WHOQOL-BREF has also demonstrated adequate psychometric properties.<sup>[28,29]</sup>

### Perceived social support

The Arabic version of the Medical Outcomes Study Social Support Survey (MOS-SSS-6) was used to assess the perceived social support;<sup>[30]</sup> this is a shortened version of the original 19-item questionnaire.<sup>[31]</sup> Items relate to emotional/information support (2 items), tangible support (2 items), affectionate support (1 item) and positive social interaction (1 item). Items are scored on a 5-point scale where 1 represents a little of the time and 5 represents all the time and summed to produce a total score (range 6–30). Higher scores indicate greater perceived social support. The MOS-SSS-6 has demonstrated satisfactory psychometric properties,<sup>[32]</sup> similar to the original 19-item measure,<sup>[31]</sup> as did the Arabic version.<sup>[30]</sup>

### Data analysis

First, descriptive statistics were conducted to provide an overview of the sample characteristics. Second, measures of central tendency, kurtosis, skewness, Pearson's correlation coefficients and reliability coefficients were calculated for each of the measures used. Third, a path analysis was conducted to investigate the proposed theoretical domain structure linking fear of COVID-19 with perceived social support, mental well-being and QoL.

### Four models were assessed

1. Model 1 considered FCV-19S and MOS-SSS-6 on the first tier as exogenous variables and its direct association with HADS-T followed by an indirect association with QoL [Figure 1, Model 1]
2. Model 2 considered FCV-19S and MOS-SSS-6 on the first tier as exogenous variables and its direct association with QoL followed by an indirect association with HADS-T [Figure 1, Model 2]
3. Model 3 considered FCV-19S and MOS-SSS-6 on the first tier as exogenous variables and its direct association with HADS-T followed by an indirect association with QoL and also considering a direct association from FCV-19 to QoL [Figure 1, Model 3]
4. Model 4 considered FCV-19S and MOS-SSS-6 on the first tier as exogenous variables and its direct association with HADS-T followed by an indirect association with

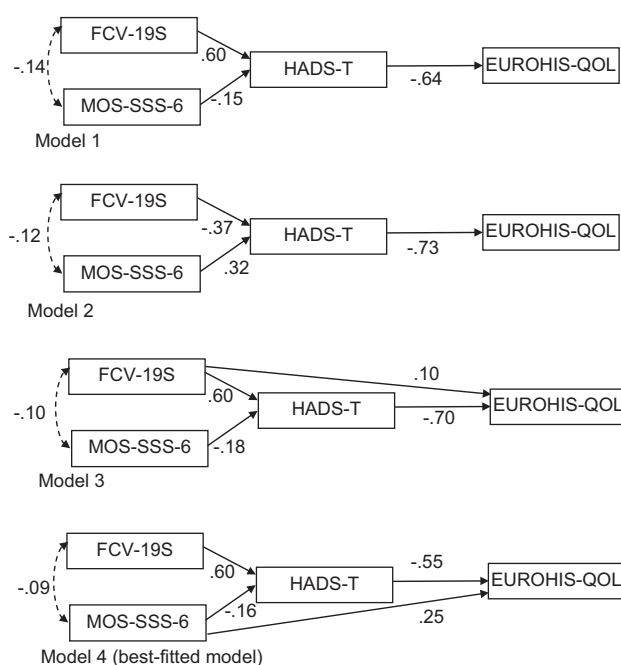

**Figure 1:** Path diagram of the tested structural equation models for all study participants. The path standardized regression weight estimates were shown only when statistically significant ( $P < 0.05$ ). For nonsignificant relationships, directive arrows are shown with dashed lines. Errors for all pertinent measures were removed to improve clarity of the figure. FCV-19S – Fear of COVID-19 Scale; HADS-T – Hospital Anxiety and Depression Scale-Total score; EUROHIS-QOL – European Health Interview Survey-Quality of Life; MOS-SSS-6 – Medical Outcomes Study Social Support Survey

QoL and also considering a direct association from MOS-SSS-6 to QoL [Figure 1, Model 4].

To conduct the path analysis and compute the fit indices, we utilized IBM SPSS AMOS 25 (IBM Corporation, Chicago, IL, USA). We assessed the path model fit indices according to the following criteria:<sup>[33,34]</sup>

1. Chi-square values can be inflated, with a larger sample size having a higher probability of a significant result.<sup>[35]</sup> Therefore, this value was used as a guide rather than as a definitive criterion
2. Root mean square error of approximation (RMSEA) values  $\leq 0.06$
3. Comparative fit index (CFI) values  $> 0.90$  (or more desirably  $\geq 0.95$ )
4. Standardized root means square residual (SRMR) values  $\leq 0.08$
5. Goodness of fit index (GFI)  $\geq 0.95$
6. Normed-fit index (NFI)  $\geq 0.95$
7. Tucker Lewis index (TLI)  $\geq 0.95$

In developing the best-fitted model, we compared the models on the criteria above and also used Akaike's

Information Criterion (AIC) and the Bayesian information criterion (BIC).<sup>[36]</sup> The AIC and BIC values allowed us to compare the information-theoretic models developed. From the candidate models, the model with the best fit was determined by identifying the lowest AIC and BIC values.<sup>[37,38]</sup>

## RESULTS

A total of 1070 responses were recorded, of which 41 participants did not provide informed consent. The final sample comprised 1029 participants who consented and completed all questionnaires. Participants' mean age was 33.7 years (SD 11.5), and male participants accounted for 52.7% of the sample. Most of the participants were married (54.3%), employed (47.2%), had completed or were in the process of completing a university degree (70.0%) and earned 9999 Saudi Riyal or less a month (57.2%). All five main geographical regions of Saudi Arabia were represented in our sample, with the majority of participants (36%) being from the Western region [Table 1].

Table 2 provides a correlation matrix and an overview of the values obtained for each of the variables. The results indicate that the values for each variable approximate a normal distribution.<sup>[39]</sup>

**Table 1: Sociodemographic characteristics of the study sample (n=1029)**

Characteristics	Frequency (%)
Sex	
Male	542 (52.7)
Female	487 (47.3)
Marital status	
Single	430 (41.8)
Married	559 (54.3)
Divorced	34 (3.3)
Widowed	6 (0.6)
Education level	
High school or less	214 (20.8)
Diploma	94 (9.1)
Bachelor	522 (50.7)
Master/PhD	199 (19.3)
Employment	
Student	311 (30.2)
Employed	486 (47.2)
Unemployed	169 (16.4)
Retired	63 (6.1)
Monthly income*	
9999 or less	589 (57.2)
10,000-15,999	208 (20.2)
16,000 or more	232 (22.5)
Region	
Central region	227 (22.0)
Northern region	77 (7.5)
Southern region	241 (23.4)
Eastern region	114 (11.1)
Western region	370 (36.0)
Personal diagnosis of COVID-19 (yes)	29 (2.8)
Family member diagnosis of COVID-19 (yes)	46 (4.5)

\*Saudi Riyal

## Path analysis

Based on the initial literature review, we mooted an *a priori* conceptual model and tested this proposed model using a path analysis approach. We considered four models that could fit with our theoretical proposition [Table 3 for fit indices attributed to each model]; however, on inspection of the parameters obtained, Model 4 was clearly the best candidate. The primary criterion variable was the FCV-19S. The values obtained for the best-fitted model (Model 4) indicated that the model fit was exemplary [Figure 1 and Table 3].

Figure 1 shows the path diagram of the tested models for all the data collected ( $n = 1029$ ). As a measure of mental well-being, the HADS-T was used due to the significant high correlations obtained between the HADS-A and HADS-D scores ( $r = 0.70, P < 0.001$ ). The path coefficients are shown for significant relationships only ( $P < 0.05$ ). The results [Figure 1, Model 4] indicated that FCV-19S significantly influenced mental well-being (HADS-T), which in turn influenced QoL. Perceived social support (MOS-SSS-6) was included in the model to assess its ability to ameliorate the relationships between FCV-19S, mental well-being and QoL. It should be noted that perceived social support had more influence on QoL than on mental well-being, suggesting that perceived social support may be more influential when predicting QoL. It is also acknowledged that a model including age and sex was trialed, but both variables did not significantly add value to the model. In addition, a direct link between FCV-19S and QoL was trialed, but this was found to be close to zero.

Hence, the narrative that best describes the path analysis is that fear of COVID-19 directly influences mental well-being, suggesting that participants with high levels of fear toward COVID-19 are more likely to experience anxiety and/or depressive symptoms. Fear of COVID-19 indirectly affects QoL through mental well-being; hence, those participants with relatively higher levels of fear of COVID-19 are more likely to be either more anxious or depressed and, as a consequence, experience relatively lower levels of QoL. The impact on QoL can, to some extent, be ameliorated by having good social support systems in place.

## DISCUSSION

The findings of this study indicate significant relationships between the fear of COVID-19, mental well-being and QoL, with some potential benefits from social support. It is widely accepted that outbreaks of infectious disease bring uncertainty and a feeling of insecurity along with decreased rational thinking, leading to psychological distress and symptoms of mental illness.<sup>[18,40,41]</sup> Fear,

**Table 2: Correlation matrix of main variables used in the model fit process (including means, standard deviations and Cronbach's alpha coefficients)**

Measure	1	2	3	Mean (SD)	Skewness	Kurtosis	Cronbach's alpha
FCV-19S				16.73 (5.67)	0.54	0.13	0.87
MOS-SSS-6	-0.09*			22.62 (6.37)	-0.72	-0.25	0.90
HADS-T	0.62*	-0.22*		10.65 (7.67)	0.87	0.45	0.89
EUROHIS-QOL	-0.31*	0.37*	-0.61*	31.32 (6.33)	-0.69	0.14	0.87

\* $P < 0.05$ . SD - Standard deviation; FCV-19S - Fear of COVID-19 Scale; HADS-T - Hospital Anxiety and Depression Scale-Total score; EUROHIS-QOL - European Health Interview Survey-Quality of Life; MOS-SSS-6 - Medical Outcomes Study Social Support Survey

**Table 3: Fit indices for each model assessed**

Model	$\chi^2$	RMSEA (90% CI)	CFI	SRMR	GFI	NFI	TLI	AIC	BIC
Model 1	93.392, df=2, $P=0.000$	0.211 (0.176-0.248)	0.811	0.077	0.955	0.809	0.432	109.392	109.470
Model 2	247.773, df=2, $P=0.000$	0.346 (0.310-0.383)	0.491	0.077	0.879	0.493	0.526	263.773	263.851
Model 3	86.095, df=1, $P=0.000$	0.288 (0.238-0.341)	0.824	0.069	0.958	0.824	-0.057	104.095	104.183
Best-fitted model (Model 4)	6.935, df=1, $P=0.008$	0.076 (0.031-0.133)	0.988	0.017	0.997	0.986	0.926	24.935	25.023

df - Degree of freedom; RMSEA - Root mean square error of approximation; CI - Confidence interval; CFI - Comparative fit index; SRMR - Standardized root mean square residual; GFI - Goodness of fit; NFI - Normed-fit index; TLI - Tucker Lewis index; AIC - Akaike's information criterion; BIC - Bayesian information criterion

insecurity, exacerbation of anxiety and a hypervigilant state are core factors that may characterize COVID-19 as a traumatic event.<sup>[13,40]</sup>

In addition to significantly straining the global healthcare and economic systems, COVID-19 imposes an unprecedented level of physical isolation (determined by public health measures) that challenges our most basic human motivations (especially our need for human connection), affecting every aspect of society.<sup>[42]</sup> The experience of a severe viral pandemic (and its social and economic fallout) creates a sense of uncertainty, triggering psychological distress, such as sadness, boredom, worry, fear, anger, annoyance, confusion, frustration, grief, guilt, helplessness, loneliness and nervousness.<sup>[2,4,8,12,41,43,44]</sup>

The actual values obtained for each of the measures [Table 2] showed that the sample of this study was fearful of COVID-19, anxious and depressed but reported high QoL scores and had reasonable social support systems. Although the FCV-19S is a developing scale without normative values, the FCV-19S mean score in our sample was comparable with scores reported in other studies with Spanish,<sup>[45]</sup> Italian<sup>[46]</sup> and Vietnamese samples<sup>[47]</sup> but lower compared with other studies conducted with New Zealand<sup>[48]</sup> and Japanese samples.<sup>[49]</sup> In accordance with the theory that fear of COVID-19 influences mental well-being, the HADS-T mean score appears to be higher in our sample than those found in other studies for similar age groups.<sup>[50]</sup> In addition, the findings in our study showed that the sampled population reported marginally higher<sup>[27]</sup> or comparable<sup>[26]</sup> QoL scores than those in the literature, which may be indicative of the social and economic standing of the sample. The perceived social support (MOS-SSS-6) scores of our study population were consistent with those cited in the literature.<sup>[32]</sup>

The current study aimed to explore the interrelationships between the aforementioned variables. The rationale behind this approach is linked to the concept that COVID-19 will likely lead to substantial and long-lasting emotional and psychological responses in the general population.<sup>[5-7,12]</sup> It has also been established that social stressors (such as health anxiety, fear of death, fear of losing loved ones, fear of the unknown, loss of social connectedness, loss of employment and homelessness) may contribute to causing new mental disorders (e.g., depression and anxiety). Similarly, such social stressors could possibly exacerbate pre-existing mental health conditions.<sup>[9,10]</sup> The findings of this study indicate that fear of COVID-19 has an impact on anxiety and depression, which in turn have an adverse impact on the QoL. Interestingly, the findings also showed that there was no direct link between fear of COVID-19 and QoL, suggesting that only those who incurred anxiety and depression were affected.

Our findings indicated that fear of COVID-19 was not correlated in a meaningful way with perceived social support. Pandemics activate annihilation anxiety - the fear of being obliterated, of annihilation of the self and dying alone - and separation anxiety - fear of loss or separation from loved ones, or fears following actual loss.<sup>[51]</sup> This may lead to intrusive thoughts related to health and even death.<sup>[13]</sup> COVID-19 presents high mortality salience (the capacity to activate our fear of death), leading to impulsive, skewed, irrational and aggressive action;<sup>[51]</sup> however, in this case, this is likely to be ameliorated by other variables rather than those linked with perceived social support, such as the influence of media reporting.<sup>[52]</sup>

Historically, epidemics have been shaping public health standards (e.g., sanitation, vaccination and healthcare

management) and demanding global solutions.<sup>[53]</sup> As COVID-19 and related social distancing measures persist (even if to a lesser degree), determining the level of associated fear, worry, helplessness and other mental health issues may support the development of interventions focused on promoting mental health and well-being.<sup>[2,4]</sup> An increase in social support seeking or connectedness may assist people as they endure the hardship associated with this pandemic,<sup>[4]</sup> although our findings imply that there are other unidentified variables that could further assist when coping with the pandemic. Therefore, there is scope for further research in identifying these variables, as this would provide a more complete picture of the problem and methods to aid in further coping with the pandemic.

Our findings should be viewed in light of some limitations. First, the cross-sectional study design limits the ability to definitively infer causal relationships. A second limitation is likely linked to not measuring other influential variables, such as the influence of media reporting. Finally, the sample consisted of predominantly well-educated and technologically literate Saudi adults, which may not represent the general Saudi population.

## CONCLUSION

This study found that the COVID-19 pandemic was associated with heightened levels of fear, anxiety and depression among Saudi adults. Increased fear of COVID-19 was directly associated with poorer mental well-being, which in turn was associated with lower QoL. Perceived social support had more influence on QoL than mental well-being. This finding highlights the importance of social support when promoting QoL, and likely has implications for coping with the problems associated with the COVID-19 pandemic.

## Ethical considerations

Ethical approval for this study was obtained from the Research Ethics Committee of Taif University (IRB 41-00155) on April 11, 2020. The study was conducted in adherence with the guidelines of the Declaration of Helsinki, 2013, and all participants provided electronic informed consent.

## Peer review

This article was peer-reviewed by two independent and anonymous reviewers.

## Financial support and sponsorship

Nil.

## Conflicts of interest

There are no conflicts of interest.

## REFERENCES

- World Health Organization. Global Research and Innovation Forum: Towards a Research Roadmap. World Health Organization Published; 2020. Available from: [https://www.who.int/publications/m/item/covid-19-public-health-emergency-of-international-concern-\(pheic\)-global-research-and-innovation-forum](https://www.who.int/publications/m/item/covid-19-public-health-emergency-of-international-concern-(pheic)-global-research-and-innovation-forum). [Last accessed on 2020 Jul 10].
- Mamun MA, Griffiths MD. First COVID-19 suicide case in Bangladesh due to fear of COVID-19 and xenophobia: Possible suicide prevention strategies. *Asian J Psychiatr* 2020;51:102073.
- Shereen MA, Khan S, Kazmi A, Bashir N, Siddique R. COVID-19 infection: Origin, transmission, and characteristics of human coronaviruses. *J Adv Res* 2020;24:91-8.
- Rubin GJ, Wessely S. The psychological effects of quarantining a city. *BMJ* 2020;368:m313.
- Tull MT, Edmonds KA, Scamaldo KM, Richmond JR, Rose JP, Gratz KL. Psychological outcomes associated with stay-at-home orders and the perceived impact of COVID-19 on daily life. *Psychiatry Res* 2020;289:113098.
- Brooks SK, Webster RK, Smith LE, Woodland L, Wessely S, Greenberg N, *et al.* The psychological impact of quarantine and how to reduce it: Rapid review of the evidence. *Lancet* 2020;395:912-20.
- Casagrande M, Favieri F, Tambelli R, Forte G. The enemy who sealed the world: Effects quarantine due to the COVID-19 on sleep quality, anxiety, and psychological distress in the Italian population. *Sleep Med* 2020;75:12-20.
- Bao Y, Sun Y, Meng S, Shi J, Lu L. 2019-nCoV epidemic: Address mental health care to empower society. *Lancet* 2020;395:e37-8.
- Shigemura J, Ursano RJ, Morganstein JC, Kurosawa M, Benedek DM. Public responses to the novel 2019 coronavirus (2019-nCoV) in Japan: Mental health consequences and target populations. *Psychiatry Clin Neurosci* 2020;74:281-2.
- Banerjee D. The COVID-19 outbreak: Crucial role the psychiatrists can play. *Asian J Psychiatr* 2020;50:102014.
- Dubey S, Biswas P, Ghosh R, Chatterjee S, Dubey MJ, Chatterjee S, *et al.* Psychosocial impact of COVID-19. *Diabetes Metab Syndr Clin Res Rev* 2020;14:779-88.
- Gunawan J, Juthamane S, Aunguroch Y. Current mental health issues in the era of covid-19. *Asian J Psychiatr* 2020;51:102103.
- Horeh D, Brown AD. Traumatic stress in the age of COVID-19: A call to close critical gaps and adapt to new realities. *Psychol Trauma* 2020;12:331-5.
- Ministry of Health. MOH Reports First Case of Coronavirus Infection. Published; 2020. Available from: <https://www.moh.gov.sa/en/Ministry/MediaCenter/News/Pages/News-2020-03-02-002.aspx>. [Last accessed on 2020 Oct 05].
- Johns Hopkins University & Medicine. Johns Hopkins Coronavirus Resource Center. Published; 2020. Available from: <https://coronavirus.jhu.edu/map.html>. [Last accessed on 2020 Jun 27].
- Saudi Center for Disease Prevention and Control. Saudi Center for Disease Prevention and Control. Published; 2020. Available from: <https://covid19.cdc.gov.sa/>. [Last accessed on 2020 Oct 07].
- Saudi Press Agency. Custodian of the Two Holy Mosques Issues Curfew Order to Limit Spread of Novel Coronavirus from Seven in the Evening Until Six in the Morning for 21 Days Starting in the Evening of Monday; 23 March, 2020. Available from: <https://www.spa.gov.sa/viewfullstory.php?lang=en&newsid=2050402>. [Last accessed on 2020 Apr 11].
- WorldAware. COVID-19 alert: Saudi Arabia revises curfew measures for Ramadan, April 23-May 24 | . Published April 21, 2020. <https://www.worldaware.com/covid-19-alert-saudi-arabia-revises-curfew-measures-ramadan-april-23-may-24>. [Last accessed on 2020 Oct 05].
- Alyami M, Henning M, Krägeloh CU, Alyami H. Psychometric evaluation of the Arabic version of the fear of COVID-19 scale. *Int*

- J Ment Health Addict 2020;1-14 [Epub ahead of print].
20. Ahorsu DK, Lin CY, Imani V, Saffari M, Griffiths MD, Pakpour AH. The fear of COVID-19 scale: Development and initial validation. *Int J Ment Health Addict* 2020; 1-9 [Epub ahead of print].
  21. Terkawi AS, Tsang S, AlKahtani GJ, Al-Mousa SH, Al Musaedi S, AlZoraigi US, *et al.* Development and validation of Arabic version of the Hospital Anxiety and Depression Scale. *Saudi J Anaesth* 2017;11:S11-8.
  22. Zigmond AS, Snaith RP. The hospital anxiety and depression scale. *Acta Psychiatr Scand* 1983;67:361-70.
  23. Bjelland I, Dahl AA, Haug TT, Neckelmann D. The validity of the Hospital Anxiety and Depression Scale. An updated literature review. *J Psychosom Res* 2002;52:69-77.
  24. Djukanovic I, Carlsson J, Årestedt K. Is the hospital anxiety and depression scale (HADS) a valid measure in a general population 65-80 years old? A psychometric evaluation study. *Health Qual Life Outcomes* 2017;15:193.
  25. Development of the World Health Organization WHOQOL-BREF quality of life assessment. The WHOQOL Group. *Psychol Med* 1998;28:551-8.
  26. Schmidt S, Mühlan H, Power M. The EUROHIS-QOL 8-item index: Psychometric results of a cross-cultural field study. *Eur J Public Health* 2006;16:420-8.
  27. da Rocha NS, Power MJ, Bushnell DM, Fleck MP. The EUROHIS-QOL 8-item index: Comparative psychometric properties to its parent WHOQOL-BREF. *Value Health* 2012;15:449-57.
  28. Dalky H, Meininger J, Al-Ali N. The reliability and validity of the Arabic World Health Organization Quality of Life-BREF instrument among family caregivers of relatives with psychiatric illnesses in Jordan. *J Nurs Res* 2017;25:224-30.
  29. Ohaeri JU, Awadalla AW. The reliability and validity of the short version of the WHO Quality of Life Instrument in an Arab general population. *Ann Saudi Med* 2009;29:98-104.
  30. Dafaalla M, Farah A, Bashir S, Khalil A, Abdulhamid R, Mokhtar M, *et al.* Validity and reliability of Arabic MOS social support survey. *Springerplus* 2016;5:1306.
  31. Sherbourne CD, Stewart AL. The MOS social support survey. *Soc Sci Med* 1991;32:705-14.
  32. Holden L, Lee C, Hockey R, Ware RS, Dobson AJ. Validation of the MOS Social Support Survey 6-item (MOS-SSS-6) measure with two large population-based samples of Australian women. *Qual Life Res* 2014;23:2849-53.
  33. Lei PW, Wu Q. Introduction to structural equation modeling: Issues and practical considerations. *Educ Meas Issues Pract* 2007;26:33-43.
  34. Marsh HW, Balla JR, McDonald RP. Goodness-of-fit indexes in confirmatory factor analysis: The effect of sample size. *Psychol Bull* 1988;103:391-410.
  35. Stage FK, Carter HC, Nora A. Path analysis: An introduction and analysis of a decade of research. *J Educ Res* 2004;98:5-13.
  36. Burnham KP, Anderson DR. Multimodel inference: Understanding AIC and BIC in model selection. *Sociol Methods Res* 2004;33:261-304.
  37. McGihon RE, Burns RJ, Deschênes SS, Schmitz N. Longitudinal associations between number of cigarettes per day and depressive symptoms in adult smokers with type 2 diabetes: A path analysis approach. *J Psychosom Res* 2019;125:109737.
  38. Zaremohzzabieh Z, Ahrari S, Krauss SE, Samah AA, Meng LK, Ariffin Z. Predicting social entrepreneurial intention: A meta-analytic path analysis based on the theory of planned behavior. *J Bus Res* 2019;96:264-76.
  39. Byrne BM, Campbell TL. Cross-cultural comparisons and the presumption of equivalent measurement and theoretical structure: A look beneath the surface. *J Cross Cult Psychol* 1999;30:555-74.
  40. Arafat SM, Kar SK, Marthoenis M, Sharma P, Hoque Apu E, Kabir R. Psychological underpinning of panic buying during pandemic (COVID-19). *Psychiatry Res* 2020;289:113061.
  41. Mukhtar S. Psychological health during the coronavirus disease 2019 pandemic outbreak. *Int J Soc Psychiatry* 2020;66:512-6.
  42. Hagerty SL, Williams LM. The impact of COVID-19 on mental health: The interactive roles of brain biotypes and human connection. *Brain Behav Immun Health* 2020;5:100078.
  43. Dsouza DD, Quadros S, Hyderabadwala ZJ, Mamun MA. Aggregated COVID-19 suicide incidences in India: Fear of COVID-19 infection is the prominent causative factor. *Psychiatry Res* 2020;290:113145.
  44. Xiang YT, Yang Y, Li W, Zhang L, Zhang Q, Cheung T, *et al.* Timely mental health care for the 2019 novel coronavirus outbreak is urgently needed. *Lancet Psychiatry* 2020;7:228-9.
  45. Martínez-Lorca M, Martínez-Lorca A, Criado-Álvarez JJ, Armesilla MD, Latorre y JM. The fear of COVID-19 scale: Validation in Spanish university students. *Psychiatry Res* 2020;293:113350.
  46. Soraci P, Ferrari A, Abbiati FA, Del Fante E, De Pace R, Urso A, *et al.* Validation and psychometric evaluation of the Italian version of the fear of COVID-19 scale. *Int J Ment Health Addict* 2020;1-10 [Epub ahead of print].
  47. Nguyen HT, Do BN, Pham KM, Kim GB, Dam HTB, Nguyen TT *et al.* Fear of COVID-19 scale-associations of its scores with health literacy and health-related behaviors among medical students. *Int J Environ Res Public Health* 2020;17:4164.
  48. Winter T, Riordan BC, Pakpour AH, Griffiths MD, Mason A, Poulgrain JW, *et al.* Evaluation of the English version of the fear of COVID-19 scale and its relationship with behavior change and political beliefs. *Int J Ment Health Addict* 2020;1-11 [Epub ahead of print].
  49. Masuyama A, Shinkawa H, Kubo T. Validation and psychometric properties of the Japanese version of the fear of COVID-19 scale among adolescents. *Int J Ment Health Addict* 2020;1-11 [Epub ahead of print].
  50. Hinze A, Brähler E. Normative values for the Hospital Anxiety and Depression Scale (HADS) in the general German population. *J Psychosom Res* 2011;71:74-8.
  51. Steele H. COVID-19, fear and the future: An attachment perspective. *Clin Neuropsych* 2020;17:97-9.
  52. Roy D, Tripathy S, Kar SK, Sharma N, Verma SK, Kaushal V. Study of knowledge, attitude, anxiety & perceived mental healthcare need in Indian population during COVID-19 pandemic. *Asian J Psychiatr* 2020;51:102083.
  53. Bonneux L, Van Damme W. An iatrogenic pandemic of panic. *BMJ* 2006;332:786-8.