



Cold plasma treatment influences the physiological parameters of millet

J. PERNER , J. MATOUŠEK, and H. AUER MALINSKÁ⁺

Faculty of Science, Jan Evangelista Purkyně University in Ústí nad Labem, Pasteurova 15, 400 96 Ústí nad Labem, Czech Republic

Abstract

In recent years, cold plasma treatment has emerged as a promising method to positively impact early seed growth. This study aimed to investigate the effects of cold plasma treatment on millet seeds with ambient air plasma discharge at pressures of 100 Pa and power ranging from 40 to 250 W. Results indicated that cold plasma treatment significantly increased radicle length by up to 112.5% (250 W) after 48 h and up to 57% (120 W) after 72 h compared to nontreated plants. The study also found that cold plasma treatment influenced electron transport during the primary phase of photosynthesis, with the effect varying with the power of discharge. However, high levels of discharge resulted in a significantly higher chlorophyll synthesis. These results suggest that cold plasma treatment may be used to reduce plant stress and improve growing properties.

Keywords: cold plasma treatment; electron transport; millet; photosynthesis efficiency.

Introduction

Plants are subjected to numerous environmental stresses, including high or low temperature, drought, salinity, or pathogen attack, which can have detrimental effects on their growth, development, and productivity (Atkinson and Urwin 2012). Monocotyledonous plants, which include major crops such as rice, wheat, and maize, are particularly vulnerable to these stresses (Fahad *et al.* 2017). Understanding the mechanisms of plant stress responses is essential to develop strategies to cope with it and ensure global crop production and food security (Mittler and Blumwald 2010).

Plant stress induces morphological, physiological, biochemical, and molecular changes that affect the growth, yield, and quality of the crop (Zarco-Tejada *et al.* 2012, Fahad *et al.* 2017). Therefore, accurate and nondestructive methods for measuring plant stress are essential for stress detection (Murchie and Lawson 2013). Nondestructive methods, such as chlorophyll (Chl) fluorescence and the reflectance of plant pigments, have been used to assess plant physiological parameters (Ehlbeck *et al.* 2011, Zarco-Tejada *et al.* 2012, Murchie and Lawson 2013, Godic *et al.* 2014, Jadoon *et al.* 2015, Nakai and Tsuruta 2021).

In recent years, researchers from all over the world have been focusing on plasma seed modifications to enhance

Highlights

- Cold plasma treatment shows potential for improving the early growth of millet seeds
- Cold plasma treatment influenced electron transport during photosynthesis
- Cold plasma treatment may reduce plant stress and enhance growing properties

Received 31 October 2023

Accepted 24 January 2024

Published online 22 February 2024

⁺Corresponding author

e-mail: hana.malinska@ujep.cz

Abbreviations: CrI1 – carotenoid index 1; Ctr1 – Carter index 1; ET_0/RC – the electron transport flux (further than Q_A^-) per reaction centre (RC); F_m – maximal fluorescence yield of the dark-adapted state; F_v/F_m – maximal quantum yield of PSII photochemistry; G – greenness index; MCARI – modified chlorophyll absorption in reflectance index; OES – optical emission spectroscopy; PI_{Abs} – performance index for the photochemical activity; PI_{Tot} – performance index on total energy basis; PQ – plastoquinone; RNS – reactive nitrogen species; ROS – reactive oxygen species; Φ_{E_0} – the quantum yield of electron transport; Φ_{Pav} – the average quantum yield for primary photochemistry; Ψ_0 – the probability that a trapped exciton moves an electron into the electron transport chain beyond Q_A^- .

Acknowledgements: This work was supported by grants UJEP-SGS-2018-53-006-3 and UJEP-SGS-2021-53-007-1 within the Student Grant competition at UJEP.

Conflict of interest: The authors declare that they have no conflict of interest.

the properties of seeds and mature plants (Mildažiienė *et al.* 2019, Shelar *et al.* 2022). Plasma is an energized state of gas, which is widely known as the fourth state of matter. It consists of species such as electrons, atoms, free radicals, ions, and photons (Chen 2016). Plasma discharge can be either thermal or nonthermal. Thermal plasma (high-temperature or equilibrium plasma) is in thermodynamic equilibrium, making it unsuitable for the treatment of biological material due to its high temperature. Nonthermal plasma (cold plasma or nonequilibrium plasma), on the other hand, is not in thermodynamic equilibrium, making it suitable for the treatment of biological material, as the temperature of discharge is near room temperature (Bès *et al.* 2018, Lin *et al.* 2022).

Understanding the mechanisms of plant stress responses and developing accurate and nondestructive methods for stress detection is crucial for ensuring global crop production and food security. Furthermore, plasma seed modifications offer a promising approach to enhancing the properties of both seeds and mature plants. The nonthermal plasma discharge can be utilized for the treatment of biological materials, which could lead to the development of new strategies to cope with plant stress (Shelar *et al.* 2021, 2023).

Plasma, an ionised gas composed of electrons, ions, radicals and photons, produces various effects when applied to seeds. From a physical point of view, plasma treatment brings about changes in the surface properties of the seeds and improves properties such as surface roughness, wettability, and permeability (Ranieri *et al.* 2021). These modifications allow better water absorption and germination speed. At the same time, plasma germicidal properties eliminate seed-borne pathogens and reduce the risk of crop diseases (Leti *et al.* 2022). However, interesting aspects of plasma–seed interactions lie in the field of biochemistry. Plasma triggers the activation of various enzymes important for seed metabolism and supports the conversion of stored nutrients into energy for seedling growth (Mildaziene *et al.* 2022). In addition, it induces changes in the metabolite profile of the seeds, potentially enriching them with beneficial phytochemicals.

Effects of various cold plasma treatments on seed properties were published (*e.g.*, Dhayal *et al.* 2006, Šerá *et al.* 2010, Li *et al.* 2014, Randeniya and de Groot 2015, Sivachandiran and Khacef 2017). Treatments in published experiments were mostly performed in rotary drum, DBD or arc discharge chamber apparatuses with time of treatment from min to hours. Seeds of many different plants were treated in plasma discharge to improve their properties – cereals (Bormashenko *et al.* 2012, Dobrin *et al.* 2015), oil plants (Šerá *et al.* 2013, Li *et al.* 2014), legumes (Volin *et al.* 2000, Li *et al.* 2014, Švubová *et al.* 2020, 2021) or vegetables such as radish (Volin *et al.* 2000) and tomatoes (Li *et al.* 2014), and pine (Scholtz *et al.* 2019). Many interesting changes in the properties of seeds by their modifications in plasma discharge have been published.

The most published studies about plasma modifications of plants of the subfamily Panicoideae deal with maize (Dasan *et al.* 2016, Sidik *et al.* 2018, Zahoranová *et al.*

2018). These studies proved that it is possible to improve the properties of plant seeds from the Panicoideae subfamily. Zahoranová *et al.* (2018) treated maize in cold atmospheric pressure ambient air plasma generated by diffuse coplanar surface barrier discharge and successfully increased the wettability of the treated seed surface which was caused by changes in the chemical composition of the surface. Increased wettability was followed by increased water absorption of treated seeds. On the other side, samples exposed to plasma discharge for more than 180 seconds had significantly decreased germination rate. They also completely devitalised a naturally occurring microbiota on the maize surface, which confirmed the disinfection effect of plasma discharge. The possibility of disinfection of maize surface was also proved by Dasan *et al.* (2016). Sidik *et al.* (2018) describe that plasma treatment could affect both positively and negatively the speed of growth of maize.

In our study, the goal was to determine the optimal conditions for low-pressure, nonthermal air plasma discharge treatment in a downer-type fluidized bed reactor to improve the properties of *Panicum miliaceum* seed surface and enhance their growing abilities. The use of a plasma downer-type reactor is innovative because it allows for extremely fast treatment with similar results compared to previously published studies.

Materials and methods

Millet seeds: Common millet seeds (*Panicum miliaceum*) produced in the Czech Republic were bought in the local seed market. Only healthy, undamaged seeds were used for the experiments.

RF plasma apparatus and plasma treatment process: Plasma treatment was performed in the downer-type reactor (Fig. 1) equipped with *Advanced Energy Cesar 136 RF* power generator and matching unit *MFJ Versa Tuner III*. RF plasma glow discharge of frequency 13.56 MHz was ignited in a quartz tube (length of

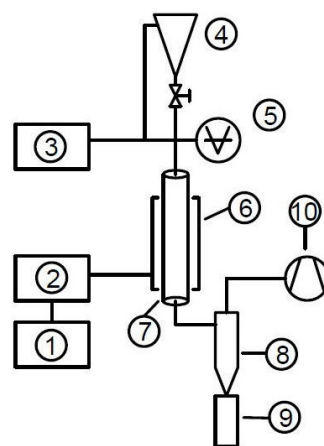

Fig. 1. 1 – generator; 2 – matching unit; 3 – mass flow controller; 4 – dispenser; 5 – vacuum gauge; 6 – electrodes; 7 – glass tube; 8 – cyclone separator; 9 – collector; 10 – vacuum pump.

700 mm, inner diameter of 20 mm) surrounded with ring electrodes made from copper stripes that were about 10 mm wide. There were 12 such ring electrodes arranged in alternating order (*i.e.*, even electrodes were connected as well as odd ones) with 10-mm gaps between electrodes. This arrangement resulted in approx. 250-mm long plasma region in the middle of the discharge tube. The tube was connected with a dispenser and a cyclone separator. The system was pumped using a rotary vane vacuum pump. The gas feed (air) was controlled by a mass flow controller, flow of 40 sccm was used.

Millet seeds were put into the dispenser and the whole apparatus was evacuated to a background pressure of about 10 Pa. The ambient air was fed into the apparatus to provide the required pressure of 100 Pa through the mass flow controller, and then plasma discharge was started in the discharge tube. The power of discharge was varied in the range from 40 to 250 W in this study. Seeds were falling from the dispenser through the valve into the discharge tube and then collected in the cyclone separator. The time of plasma treatment of seeds was in the order of 0.1 s. This time was achieved as a time of free fall through the plasma zone. Every seed was exposed to vacuum for less than 1 min, which was enough time for set parameters of experiment and treatment of seeds. All experiments were carried out in the air-conditioned laboratory. The temperature during experiments was between 20–22°C, humidity varied from 30 to 35% (as measured by USB datalogger *Gar 171* from *Garni*).

Plasma discharge diagnostics with optical emission spectroscopy (OES): The *AvaSpec-ULS2048CL-EVO* (*Avantes*, The Netherlands) spectrometer was used to measure optical spectra of plasma discharge. Spectra were measured in the range of 200–1,100 nm with a resolution of 0.344 nm. The observation was done through a quartz tube.

Germination rate: Millet seeds were planted in Petri dishes filled with seven layers of filtration paper saturated with distilled water. In every Petri dish, 20 seeds were planted and germinated seeds were counted 48 h later. Since the modification showed almost no effect on germination, the graph is provided as Fig. 1S (*supplement*).

Speed of growth in the early stage: Millet seeds were planted in Petri dishes filled with seven layers of filtration paper saturated with distilled water. In every Petri dish, ten seeds were planted. Germs were measured 48 and 72 h after planting. Before measurement germs were carefully straightened to prevent measurement error and their rupture. Part of the seeds were germinated to explore the long-term effect of cold plasma discharge on vegetative tissues. Seeds were planted in standard compost soil (*Agro*, Czech Republic) and incubated in controlled conditions (*Phytoscope*, *PSI*, Czech Republic) at 20°C and photoperiod of 16 h/8 h light/dark. The whole experiment was repeated three times, and every measured value underwent the 3 σ test.

Plant physiology parameters: Plant stress indicators were measured in six plants. A noninvasive method of fluorescence measurement was conducted, using the handheld device *FluorPen FP 110* (*PSI*, Czech Republic), which is equipped with an LED emitter (455 nm), emitting a maximum light intensity of 3,000 $\mu\text{mol}(\text{photon})\text{ m}^{-2}\text{ s}^{-1}$. The detector is a photodiode with 667 to 750-nm bandpass filters. Fluorescence was measured after 15 min of dark adaptation of samples, the third fully developed leaf was measured in all plants. Various fluorescence indexes were calculated according to the manufacturer's instructions. The same leaf was measured by *PolyPen PR410 UVIS* (*PSI*, Czech Republic) to assess the content of leaf pigments, wavelengths between 340–780 nm. In addition, different vegetation indexes were calculated. Plant height was measured 70 d after planting.

Biomass: At the end of the vegetation season, aboveground biomass was harvested, and total and seed biomass was weighed after complete drying (105°C, 24 h).

Wettability changes: Changes in wettability were investigated by the water contact angle measurement method. Computer-based *See System* by *Advex Instruments* was used. Drops of distilled water (1.5 μl) were used to measure the contact angle. One drop of water was put on every single seed and apparent water contact angle was measured. Measurement was repeated 20 times for each variant.

Statistical data analysis: Significant differences between samples were evaluated using the one-way analysis of variance (*ANOVA*) and the group of data was compared to the control group by the *Student's t*-test. Differences were considered significant for $P < 0.05$. Values are expressed as arithmetic mean \pm standard deviation (SD) of at least three measurements. The number of each experiment (n) is included in figure description.

Results and discussion

Plasma diagnostics: OES serves as a tool for characterizing the elemental composition of the plasma, offering insights into the excited species present within the discharge. Through the analysis of emission spectra, we gain a comprehensive understanding of the elemental constituents involved in the plasma treatment process.

Since ambient air is used as the working gas in the discharge, the spectrum mainly consists of peaks belonging to various excited states of nitrogen and oxygen species. The representation of individual species varies with the discharge power used (Fig. 2). Spectra of 40 W discharge is composed of nitrogen molecules the second positive system originated from the transition $\text{N}_2\text{ C}^3\Pi_u$ to the $\text{N}_2\text{ B}^3\Pi_g$ with a main peak at 337 nm (Fig. 2A) (Ílik *et al.* 2020) and the first positive system originated from transition $\text{N}_2\text{ B}^3\Pi_u$ to the $\text{N}_2\text{ A}^3\Sigma_u^+$ (Fig. 2B) (Shibusawa and Funatsu 2019). With increasing power of discharge, especially at 120 W and 250 W, there is a significant

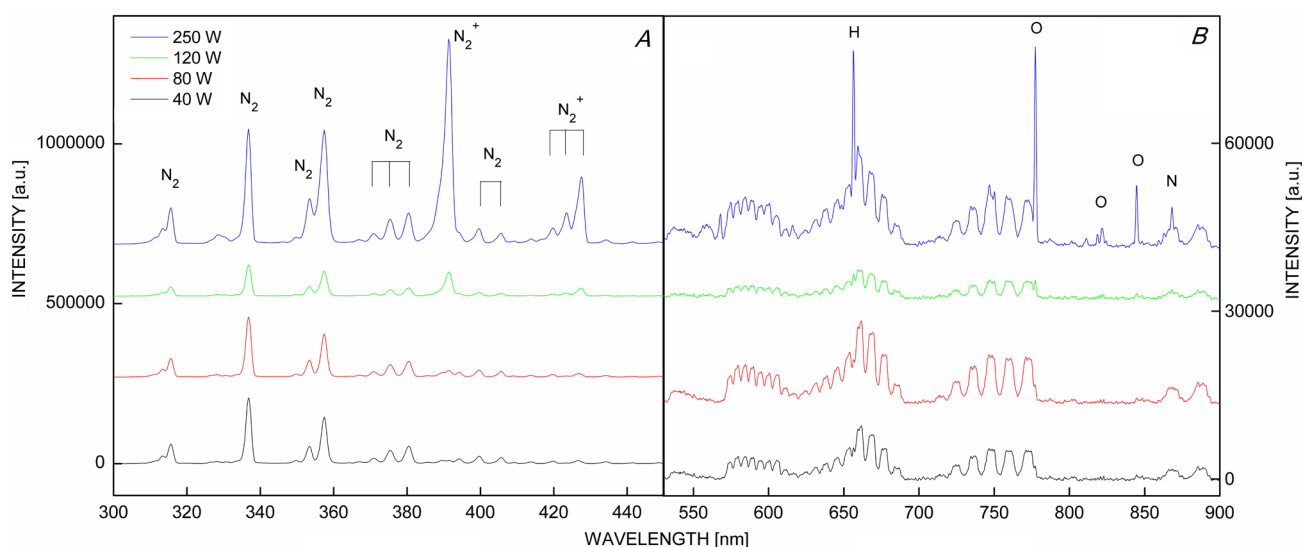

Fig. 2. Optical emission spectra of plasma discharge. (A) Range of spectra 300–450 nm containing dominant N_2 second positive system and N_2^+ first negative system; (B) range of spectra 525–900 nm containing atomic oxygen peaks. Both spectra were normalized to 1,000-ms integration time.

presence increase of N_2^+ first negative system $B^2\Sigma_u^+ - X^2\Sigma_g^+$ with a main peak at 391 nm. Typical atomic oxygen peaks at wavelength 777 nm and 844 nm had significantly increased measured intensity at 250 W. The ratio of measured intensities changed with the power of discharge (Fig. 3).

The effect of treatment on the early stage of growth:

The effect of cold plasma treatment on seeds is dependent on the power of discharge. Cold plasma treatment had a very positive effect on the early stage of seed growth. All treated samples showed significantly longer radicles than untreated samples (Fig. 4). Treated samples measured 48 h after planting had length increased by 45.8% (40 W) up to 112.5% (250 W). 72 h after planting the difference was not so enormous, but still significant. An increase in length varied from 36.5% (80 W) up to 57% (120 W) but only the 120 W sample had a significant difference from the reference sample according to *ANOVA*.

The measured rapid growth of treated samples in the early stage corresponds with published literature (Li *et al.* 2014, Dobrin *et al.* 2015, Zahoranová *et al.* 2018). Despite the fact, that the sample is exposed to plasma discharge for less than 1 s, improvement of sample properties in the early stage of growth could surpass the properties improvement of samples which interacted with plasma discharge for a significantly longer time. Rapid cold plasma treatment in the downer-type reactor with conditions used in this experiment prevents a significant reduction of speed of growth in later stages described with the treatment of maize (Sidik *et al.* 2018).

Effect on plant physiology: In green plants, the effectivity of photosynthesis can be strongly influenced by external factors (Miller *et al.* 2010). Stress caused by these factors often results in decreased fitness and yield of the crop. In this experiment, plasma treatment of millet seeds was

used as a potential agent for the reduction of plant stress. Noninvasive methods such as measurement of plant fluorescence ensure minimal damage to the leaf and yet it can give valuable information about the physiological state of the plant.

The OJIP curve provides a basic understanding of how any factor affects the primary phase of photosynthesis

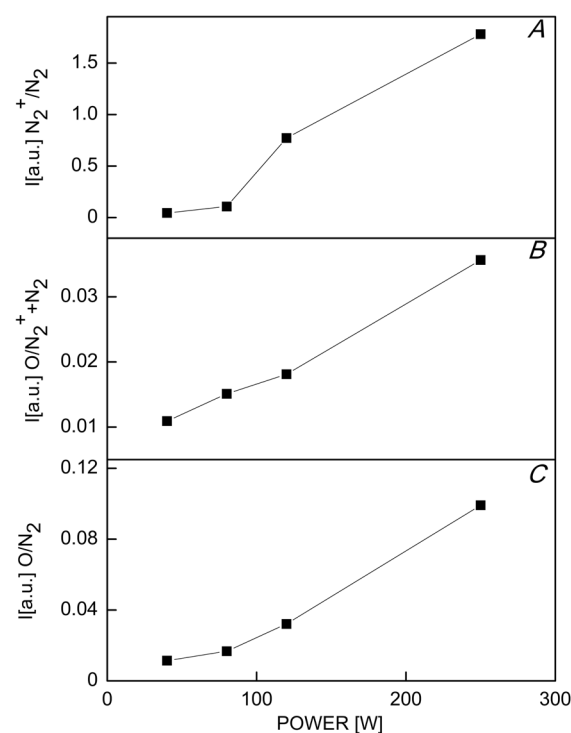

Fig. 3. Ratios of measured intensities: (A) N_2^+ 391 nm/ N_2 337 nm; (B) atomic oxygen 777 nm/sum of N_2 337 nm and N_2^+ 391 nm; (C) atomic oxygen 777 nm/ N_2 337 nm.

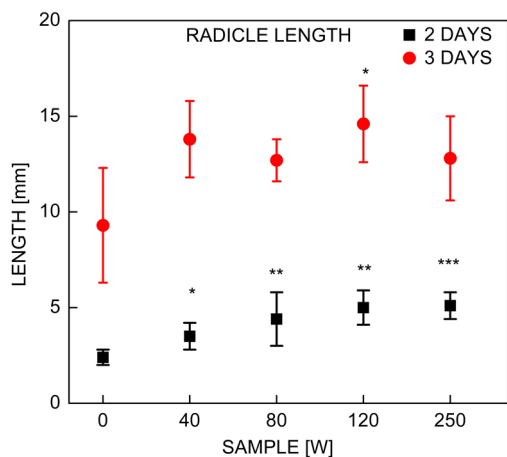

Fig. 4. Millet radicle length 48 and 72 h after planting. Values are the arithmetic mean \pm SD. The significance was determined against untreated samples. All results were significant at * $P < 0.05$; ** $P < 0.01$; *** $P < 0.001$, $n = 10$.

(Maxwell and Johnson 2000). In this case, the OJIP curve can help determine the efficiency of photosynthesis in response to the specific factor being studied (*i.e.*, power of discharge). At first glance, the curves of all variants may seem very similar, but with closer inspection, it becomes apparent that there are slight variations in the shape and amplitude of the curves. Each curve was reconstructed as the mean of six measurements taken at the same time by six individuals to account for potential individual differences. Group '0 W' (Fig. 5) can be handled as control plants since no power of discharge was applied to the seeds before planting. The other groups, however, were subjected to different levels of discharge power. Group 40 W exhibits similar values of the F_0 (or O-step) step as control plants when compared to control plants (0 W), indicating that this power of discharge had little impact on the PSII's initial state. The PSII reaction centres of 40 W plants seem to be ready to accept energy and begin the process of photochemistry. Still, group 80 W had a slightly higher fluorescence level in the O-step compared to the control. This could mean that the PSII started to be influenced by the stress caused to seeds by the plasma and a few reaction centres may be in a semi-reduced state. Groups 120 W and 250 W showed significantly higher values of F_0 compared to control plants. This indicates that there may be an increased level of stress on the PSII, potentially leading to a larger number of reaction centres being in a semi-reduced state. Additionally, the higher values of the F_0 suggest that there was a disruption in the normal flow of electrons, possibly due to an imbalance in the PSII reaction centres.

During the J-phase, which occurs around 2 milliseconds after illumination, the control at 0 W serves as a reference point for studying the initial electron transport through PSII. This is crucial for gaining insights into how plants respond to stress. With a power output of 40 W, the J-phase curve closely resembled that of the control, indicating that this discharge power did not have a significant impact on electron flow through PSII. However, based on certain

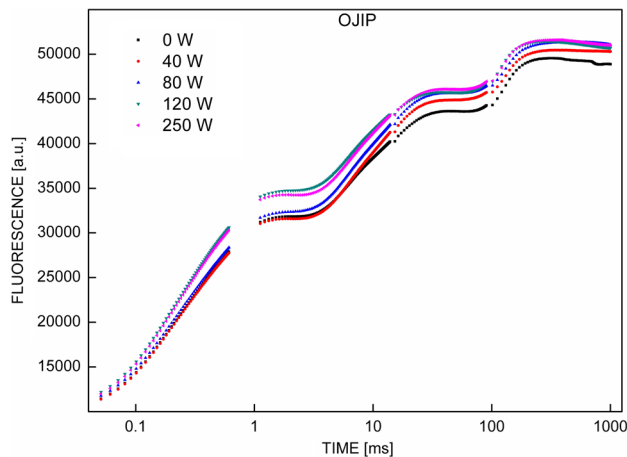

Fig. 5. OJIP curve representing fast fluorescence induction curve. The curve was reconstructed as a mean of 6 measurements, $n = 6$.

experimental variations, there seems to be a possible malfunction in the process of electron transfer. When the J-phase elevation surpasses the control at 80 W, it suggests a potential bottleneck in the electron transport chain (Strasser *et al.* 1995, 2004; Stirbet *et al.* 1998, Stirbet and Govindjee 2012). This bottleneck seems to occur specifically at the transfer point from PSII to the plastoquinone (PQ) pool. This rise indicated the onset of slight stress. At higher power of discharge (120 W and 250 W), there was a more noticeable increase in the J-phase, suggesting a significant bottleneck and indicating that the electron transport chain was approaching saturation. In the case of these higher-power plasma treatments, the electron transfer process becomes overwhelmed and unable to keep up with the influx of electrons. This saturation point indicated that the electron transport chain was reaching its maximum capacity and was unable to efficiently transfer electrons from PSII to the PQ pool (Stirbet *et al.* 1998, Stirbet and Govindjee 2012). This bottleneck in electron transfer could potentially lead to an accumulation of electrons and an imbalance in the redox reactions within the chain, resulting in oxidative stress and potential damage to the photosynthetic system. This oxidative stress can lead to the production of reactive oxygen species (ROS), such as superoxide radicals and hydrogen peroxide, which can damage proteins, lipids, and DNA within the chloroplast. Additionally, the accumulation of electrons can disrupt the balance between the light-dependent and light-independent reactions of photosynthesis, negatively impacting carbon fixation and ultimately reducing the overall efficiency of photosynthesis. To mitigate these potential damages, plants have evolved various protective mechanisms, such as antioxidant enzymes and nonphotochemical quenching, to regulate the flow of electrons and minimize oxidative stress.

During the I-phase (Fig. 5, around 30 milliseconds), the level of fluorescence in this step for the control sample (0 W) indicated the progress of electron transport beyond the PQ pool and the efficiency of the downstream

electron transport chain. When the power was set to 40 W, it appeared that the electron transport chain was able to handle the flow of electrons well, which helped maintain the proper functioning of photosynthesis. This is indicated by the congruence observed with the control's I-phase trajectory. Under the influence of the 80 W treatment, there was a small rise in the I-phase compared to the control, indicating that the electron transport chain was facing higher reduction pressure. These findings suggest that there may be early indications of constraints in the electron transport process, possibly occurring at the cytochrome *b₆/f* complex or a later stage in the electron transport chain. When the power was set to 120 W and 250 W, there was a noticeable increase in the I-phase, suggesting a significant boost in the reduction state of the electron carriers between PSII and PSI. This increase indicates an excessively reduced state, which can activate stress responses such as the utilization of alternative electron sinks or photoprotective mechanisms. The observed response indicates a notable influence on the photosynthetic system,

resulting in the development of changes in photosynthetic efficiency associated with stress.

During the P-phase, the peak fluorescence (F_m) is reached, which indicates the closure of all PSII reaction centres. The control at 0 W serves as a reference point for the highest fluorescence yield in the dark-adapted conditions. With the increase in power to 40 W, there was a subtle indication of an elevation in the P-phase (Fig. 5) and a noticeable rise in the P-phase at 80, 120, and 250 W. In a normal situation, it would imply a stimulatory effect of cold plasma similar to increased nutrition or the application of stimulating compounds (Malinská *et al.* 2020, Auer Malinská *et al.* 2021), however, the interpretation of these findings can often be difficult and requires additional data, such as details regarding leaf pigment content and biomass quantity, to conclude the plant's physiological condition.

OJIP itself does not explain which processes within the system are truly influenced by the plasma treatment. Therefore, some fluorescence indices were calculated from basic fluorescence data for a better understanding

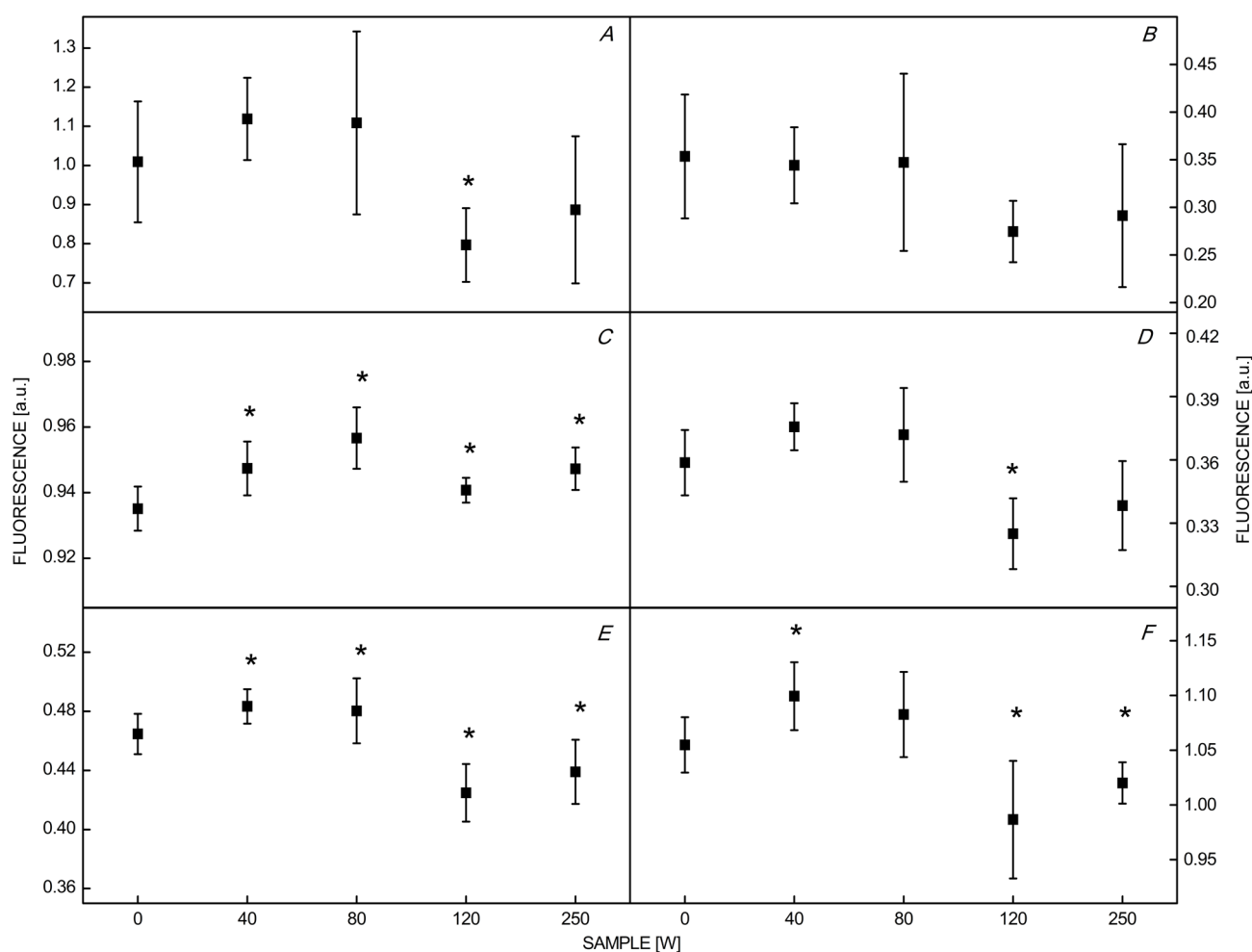

Fig. 6. Plant physiology parameters based on plant fluorescence. Results were significant at $*P < 0.05$, $n = 6$. Columns represent mean value; error bars represent standard deviation. (A) Performance index for the photochemical activity (PI_{Abs}); (B) performance index on total energy basis (PI_{Tot}); (C) the average quantum yield for primary photochemistry (Φ_{Pav}); (D) the quantum yield of electron transport; (Φ_{Eo}); (E) the probability that a trapped exciton moves an electron into the electron transport chain beyond Q_A^- (Ψ_0); (F) the electron transport flux (further than Q_A^-) per reaction centre (ET_0/RC).

of the problem. Fig. 6 shows the chosen indices, first, the performance index (PI), which is widely used to quantify plant health (Živčák *et al.* 2008, Brestic and Zivcak 2013, Bussotti *et al.* 2020). PI_{Abs} and also PI_{Tot} (Fig. 6A,B) show lowered values for plants that grew from seeds treated by discharge of 120 and 250 W. That is by plant appearance since these two variants were much smaller than the control and also the other two variants. Variants 40 W and 80 W were the highest, even higher than untreated plants (0 W). These two variants also display higher values of PI_{Abs} , unfortunately, this elevation is not statistically significant. The only significant value is a decrease in PI_{Abs} in variant 120 W.

At lower discharge powers, elevated PI_{Abs} was observed, indicating a potentially improved efficiency of the photosynthetic activity. However, across all experimental variants, the PI_{Tot} was consistently diminished, suggesting the presence of energy losses during photosynthesis. The extent of these losses was especially pronounced at 120 W and 250 W, suggesting that the increased stress from higher discharge powers could be detrimental to the photosynthetic system. It is crucial to note that while PI_{Abs} and PI_{Tot} serve as sensitive indicators (Živčák *et al.* 2008), in this experiment, their substantial standard deviations warrant caution in interpreting the results and drawing definitive conclusions.

Looking at other indices, some kind of trend is visible. Most fluorescence indices display slight elevation for lower discharge (40, 80 W) and decrease for higher values of discharge (120, 250 W). For example, Ψ_0 (Fig. 6E), the efficiency, that trapped exciton will move electrons further to the electron transport chain, is significantly lowered in higher levels of discharge and higher than control plants in the lower level of discharge implying that cold plasma treatment did not have a uniform effect on subsequent life of the plant. This type of treatment strongly influences electron transport (ET_0/RC , Fig. 6F) in the primary phase of light reaction.

We discovered that the application of various powers of cold plasma to plant seeds leads to alterations in the physiological properties of mature plants. Specifically, there was a modulation of electron transport in PSII, as indicated by ET_0/RC values. Our data demonstrate that at lower power of discharge, the ET_0/RC value was elevated, whereas at higher wattages, the ET_0/RC value was reduced. The possible interpretation of this observation is that mild doses of cold plasma might stimulate the activity of PSII, enhancing the efficiency of electron transport per reaction centre (ET_0/RC). This could be a result of mild oxidative stress, activating the plant's defence mechanisms and bolstering the photosynthetic apparatus. On the other hand, high doses of plasma might damage the photosynthetic apparatus, diminishing the efficiency of electron transport. This could be attributed to excessive production of reactive oxygen species, damaging proteins, lipids, and DNA (Foyer and Noctor 2011).

At higher plasma doses, notably at 120 and 250 W, we observed discernible changes in several key photosynthetic parameters. The quantum yield of electron transport denoted as Φ_{E_0} (Fig. 6D), displayed a decrease, signifying

a potential impairment or inactivation of PSII reaction centres. Such a trend is a robust indicator of plant stress (Baker 2008), strongly suggesting that escalated doses of cold plasma might be compromising the plant's primary photochemistry (Takahashi and Badger 2011).

Furthermore, the probability of trapped exciton movement, represented by Ψ_0 , manifested a significant reduction at these specific doses. This inefficiency in electron transport beyond Q_A^- could be attributed directly to oxidative stress (Mittler 2002). Such stress, conceivably arising from the amplified contents of ROS and RNS (Apel and Hirt 2004), holds the potential to damage the photosynthetic machinery, culminating in a diminished probability of exciton movement.

On the contrary, Φ_{Pav} values (Fig. 6C) increased significantly in all treated plants, which is following OJIP results. To clarify these discrepancies, further analyses were performed.

Plant reflectance can provide additional information about plant pigments, which are crucial for the photosynthetic process. Indirect analysis of plant pigments also revealed different effects of higher and lower amounts of discharge. However, the effect was completely different from that in plant fluorescence. The higher dose of discharge caused increased relative amount of Chl (MCARI, Fig. 7A). Lower discharge caused decrease of pigment synthesis, mainly of plant protective pigments, carotenoids (Cri1, Fig. 7C). Since carotenoids are formed in case of stress, lower content in 40 W and 80 W suggests that these plants thrive, and plants treated with high discharge (120 W and 250 W) display high content of all leaf pigments (Fig. 7). Total and seed biomass data prove that application of 250 W discharge created enormous stress resulting in a massive decrease of the total as well as seed biomass. The mass of dry total biomass (seed biomass, respectively) was as follows. For control 0 W, the total dry mass was 19.52 g (7.31 g, respectively), for 40 W it was 17.34 g (7.40 g for seeds), in variant 80 W, the dry mass was 18.51 and 8.08 g for seeds. In 120 W, the dry mass reached the value of 20.59 g, which was the highest mass of all variants and also seed mass (9.09 g) was the highest of all variants investigated. On the other hand, variant 250 W had the lowest biomass mass (14.16 g) as well as the total seed mass (5.40 g) of all variants.

Changes in the wettability of the seed surface after cold plasma treatment were observed by apparent water contact angle measurement, 20 seeds were measured from every sample. Oxygen content in ambient air used as working gas of plasma discharge usually causes changes in surface chemical groups and oxygen/carbon ratio, thus increasing the polar part of surface energy which increases wettability of seeds surface (Ferrero 2003, Arpagaus *et al.* 2005). The increase of surface wettability was confirmed by a decrease in apparent water contact angle after treatment (Fig. 8). Water contact angle decreased from $118 \pm 5^\circ$ by 13% (40 W) to 21% (250 W). The decrease of water contact angle after treatment in the downer-type reactor is not as significant as after treatment in apparatus designed for a long exposure of sample to plasma discharge,

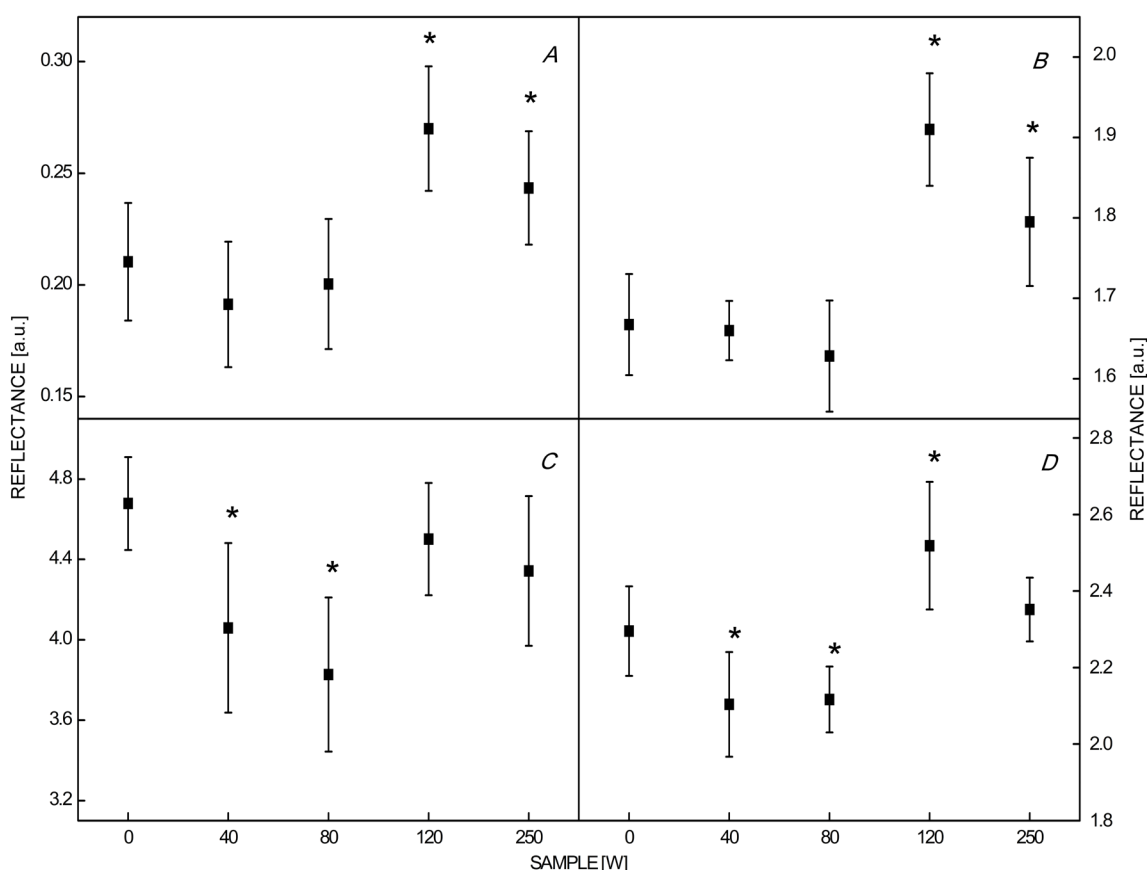

Fig. 7. Plant physiology parameters based on leaf pigment reflectance. Results were significant at $*P < 0.05$, $n = 6$. Columns represent mean value; error bars represent standard deviation. (A) Modified chlorophyll absorption in reflectance index (MCARI); (B) Carter index 1 (Ctr1); (C) carotenoid index 1 (Cri1); (D) greenness index (G).

such as DBD, rotary drum reactor, *etc.* (Zahoranová *et al.* 2018, Švubová *et al.* 2021). The significant increase in speed of growth despite the low increase of wettability proves that the effect of cold plasma treatment is complex and affects multiple parameters causing faster growth.

Plasma is known to generate various reactive oxygen and nitrogen species that function as signalling molecules, initiating transcription cascades. The effects of plasma treatment are reported to vary depending on factors such as dosage, treatment time, moisture, and reactor type. Prolonged exposure to high doses of plasma has been observed to result in reduced seedling growth, as demonstrated in wheat (Šerá *et al.* 2010). Conversely, lower doses of plasma have been found to increase early seedling growth, as demonstrated by Dobrin *et al.* (2015). Despite the numerous examples of plasma treatment demonstrating enhanced plant tolerance to abiotic stresses, such as drought in *Brassica* (Li *et al.* 2014) and salt in *Arabidopsis* (Bafail *et al.* 2019), few studies have investigated the resulting physiological changes in monocots. In wheat, for instance, the use of oxygen and argon gases within the plasma reactor increased the plant's tolerance to heavy metals (Kabir *et al.* 2019), while nitrogen-activated barley seeds showed increased drought tolerance (Gierczik *et al.* 2020). Notably, our study of millet showed improved

physiological values even without the use of any reactive gases.

In our study, we observed a contrasting trend between the electron transport in PSII and the Chl content indicators,

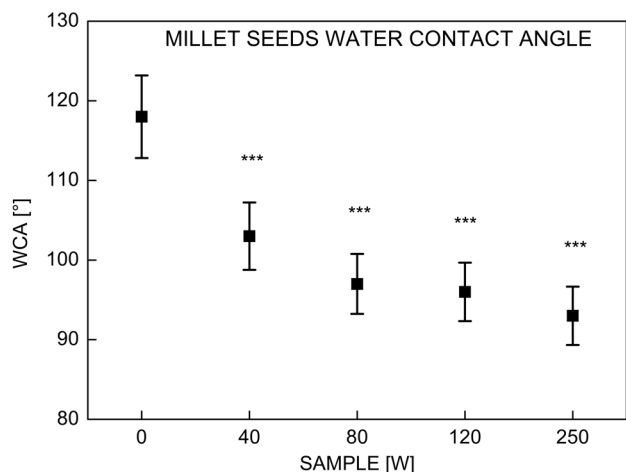

Fig. 8. Apparent water contact angle. Values are the arithmetic mean \pm SD. The significance was determined against untreated samples (0 W). Results were significant at $*P < 0.05$; $**P < 0.01$; $***P < 0.001$, $n = 20$.

namely the MCARI, GI, and Ctrl parameters. At higher plasma wattages, while the ET_0/RC values decreased, indicating potential harm to the photosynthetic apparatus whereas the relative Chl content appeared to increase. A similar result appeared in Jiang *et al.* (2014) in cold plasma (80 W)-treated wheat. *Triticum aestivum* plants displayed almost a 10% increase in Chl compared to nontreated individuals.

One plausible explanation for this observation could be the phenomenon of damage compensation. Some plants, when subjected to mild stress, can enhance their production of Chl and other pigments as a compensatory response (Lichtenthaler 1996, Lichtenthaler and Burkart 1999). Such an increase in Chl could be a strategy to maximize light capture and compensate for reduced photosynthetic efficiency due to damage at the PSII level. The effect of cold plasma treatment on plant physiology has not yet been performed in such detail, but previous research has shown that certain stress factors, like drought, can trigger plants to adjust their physiology, including an increased accumulation of soluble sugars, as a compensatory mechanism in the face of PSII damage (Moustakas *et al.* 2011).

Given the evident stress markers in the plants treated with 120 W and 250 W, it is intriguing yet consistent with plant physiology that we also observed increased production of photosynthetic pigments. It is well-documented that plants exhibit compensatory mechanisms when confronted with adversities. When the photosynthetic machinery undergoes impairment or inefficiencies, a surge in Chl production can occur, acting as a compensatory response to optimize light absorption (Murchie and Lawson 2013). This increase in Chl can be seen as a plant's endeavour to offset the lowered photosynthetic efficiency, given the disruptions to the apparatus, and thus maximize its use of available light (Zhang and Sharkey 2009). In this case, the upsurge in Chl content at the 120 W and 250 W treatments can be perceived as a strategic move by the plant. This increased synthesis potentially signifies a bid to mitigate the detrimental effects caused by the stressed photosynthetic machinery. The lowered PI_{Abs} due to apparatus disruption might instigate this compensatory elevation in Chl synthesis and accumulation.

Reactive oxygen species (ROS) and reactive nitrogen species (RNS) have been widely recognized as potent oxidizing agents, responsible for inflicting damage to various cellular components, including lipids, proteins, and DNA (Foyer and Noctor 2011). Augmented contents of ROS and RNS can result in oxidative damage to the intricate components of the photosynthetic machinery, notably the PSII reaction centres, D1 protein, and the associated electron transport chain (Takahashi and Murata 2008).

Our observations (Fig. 2), as deduced from optical emission spectroscopy (OES), revealed that at plasma doses of 120 W and 250 W, a pronounced increase in the generation of both oxygen and nitrogen reactive species occurs due to plasma discharge. As the spectra were normalized to the same integration time for a fair and accurate comparison of emission intensities, we can

consider, that higher intensity in one spectrum compared to the other indicates that there is a higher abundance of the corresponding emitting species in the plasma for that particular transition. While plasma discharge optical emission spectra of power 40 W and 80 W could be considered almost identical, mainly consisting of N_2 systems, only with slightly increased intensities of nitrogen first positive system peaks at 80 W discharge, the 120 W and 250 W spectra are quite different. The excitation conditions in the plasma may not be optimal for promoting the transition associated with the N_2 peaks at 120 W. The energy distribution of electrons and other species in the plasma can vary with power, affecting the number of excited states responsible for N_2 emission. On the other hand, the ideal conditions for the formation of N_2^+ -associated transitions begin to emerge. A discharge power of 250 W ensures the best conditions for the formation of all observed excited states. By far the highest intensity and thus the abundance of N_2^+ and oxygen-excited species is also accompanied by the highest N_2 intensities of both positive nitrogen systems.

This surge in ROS and RNS at these specific powers of discharge provides a tangible mechanistic link to the observed declines in the aforementioned photosynthetic parameters (Foyer and Noctor 2011). Essentially, the oxidative stress induced by these elevated reactive species could be the main contributing factor behind the diminished efficiency and potential harm inflicted on the photosynthetic apparatus at such high plasma doses (Mittler 2002). ROS, often produced under stress conditions, can serve as signalling molecules that activate defence pathways in plants (Miller *et al.* 2010). This activation can lead to the synthesis of protective compounds, including carotenoids and other secondary metabolites, to mitigate oxidative stress and potentially enhance photosynthetic apparatus protection (Fridovich 1998).

The primary biologically active component of cold plasma is an intricate blend of activated radical species generated during the dissociation, excitation, and ionization of gas atoms. The collision of high-energy electrons with molecules, such as molecular oxygen (O_2), nitrogen (N_2), and water (H_2O), in the air environment leads to chemical reactions (Turner 2016). Under conditions of relatively low gas temperature, which are typical for cold plasma, the stimulation of N_2 molecules and the separation of O_2 in the air environment might result in the buildup of ozone (O_3) (Whitehead 2016). Increased energy levels result in the separation of N_2 molecules and the generation of nitrogen oxides (NO_x) hinders the synthesis of ozone and subsequently combines to create many other reactive nitrogen species. Also, when water vapour is present, from the hydroxyl group which compounds, hydroxyl radical ($OH\cdot$) is generated. $OH\cdot$ radical is extremely unstable due to the existence of an unpaired electron, which makes it capable of easily oxidizing various organic molecules and potentially generating ozone. The reactive oxygen and nitrogen species (ROS/RNS) then have a detrimental effect on biological systems and might potentially disrupt subsequent processes such as cell signalling, gene

expression, metabolic activity, and physiological activities in the plant's future existence.

In our study, the OES spectrum revealed the appearance of reactive atomic oxygen at 777 nm and various nitrogen species. The amount of these elements increased with higher power of discharge. Although these reactive species generated in the gas-phase plasma probably do not directly interact with cells of plant embryos, they can initiate various chemical reactions at the gas-liquid interface of the seed and then form large amounts of primary and secondary reactive species that influence plant molecular processes. Higher concentrations of reactive species at 120 and 250 W might explain different features we observe in plasma-treated plants in their adult life.

An important limitation of this study is its exclusive focus on a single plant species, millet. While the findings regarding the effects of cold plasma treatment on millet seeds are indeed valuable, it is essential to recognize that different plant species may respond differently to such treatments. Plants exhibit considerable variability in their physiological and biochemical characteristics, and what may work effectively for millet might not be directly applicable to other crop varieties. Future research should aim to explore the effects of cold plasma treatment on a broader range of plant species to better understand its potential applications across diverse agricultural contexts. Despite these limitations, the study underscores the potential of cold plasma treatment as a tool to alleviate plant stress and enhance seedling growth, offering possibilities for future research and agricultural applications.

Our study is unique because it is a focused investigation of millet, specifically looking at the depth of physiological systems in mature plants – a topic that has not been in-depth explored by other researchers. Furthermore, our research utilization of a particular cold plasma device setting presents a fresh strategy. We can accurately manipulate and investigate the impacts of plasma on millet physiology thanks to this special setting, which gives us insights that are not possible with more traditional methods.

Also, our focus is on adult plants, whereas most studies have focused on seedlings or juvenile plants and their germination properties. The only, to our knowledge, exception is Zukiene *et al.* (2019), who measured F_v/F_m and PI in sunflower plants after plasma treatment.

Thus, our work not only closes a major knowledge gap regarding millet's reaction to new agronomic treatments but also establishes a precedent for the application of cutting-edge technologies to improve plant production and resilience. Our research is at the vanguard of agricultural science, delivering both fundamental insights and useful applications because of the unique subject matter of adult millet plants combined with an inventive methodology of using particular cold plasma settings.

In agriculture, applying cold plasma treatment has several intriguing advantages. By altering the seed's metabolic pathways, regulating water intake, and changing seed surface qualities, it can improve crop production, growth, and germination. Because cold plasma treatment inactivates bacteria and viruses, it can also be used to

manage pests and plant diseases. Additionally, it can increase plants' efficiency and uptake of nutrients. Because of these qualities, cold plasma can be a useful tool in sustainable agriculture, possibly increasing yield while lowering the need for chemical treatments (Pańka *et al.* 2022).

Conclusions: Our work was focused on the improvement of the growing properties of *Panicum miliaceum*. With cold plasma treatment in a downer-type fluidized bed reactor, we successfully increased the millet speed of growth in the early stages despite the very short sample exposure to plasma discharge. Increased speed of growth is connected with increased wettability of the surface, which was observed by apparent water contact angle measurement. The effect on plant physiology is dependent on the level of discharge. High doses of discharge negatively influence the electron transport pathway within PSII but on the other hand, increase the relative amount of chlorophyll. The lower dose of discharge increases electron transport and total health, which can be documented by the lower synthesis of carotenoids and overall appearance. Therefore, cold plasma seed treatment discharge 40–80 W can be recommended as a tool for the improvement of plant health without negative effects on plant physiology.

Cold plasma treatment could be used as a potential tool to enhance plant growth and reduce plant stress. The effect of cold plasma treatment on millet seed growth and photosynthetic performance varied with the power of discharge. The OJIP curve analysis and fluorescence indices suggested that cold plasma treatment influences electron transport in the primary phase of photosynthesis. Further research is needed to understand the underlying mechanisms and optimize the parameters of cold plasma treatment.

References

- Apel K., Hirt H.: Reactive oxygen species: metabolism, oxidative stress, and signal transduction. – *Annu. Rev. Plant Biol.* **55**: 373-399, 2004.
- Arpagaus C., Rossi A., von Rohr P.R.: Short-time plasma surface modification of HDPE powder in a Plasma Downer Reactor – process, wettability improvement and ageing effects. – *Appl. Surf. Sci.* **252**: 1581-1595, 2005.
- Atkinson N.J., Urwin P.E.: The interaction of plant biotic and abiotic stresses: from genes to the field. – *J. Exp. Bot.* **63**: 3523-3543, 2012.
- Auer Malinská H., Vaněk M., Nebeská D. *et al.*: Plant priming changes physiological properties and lignin content in *Miscanthus × giganteus*. – *Ind. Crop. Prod.* **174**: 114185, 2021.
- Bafoif M., Le Ru A., Merbahi N. *et al.*: New insights of low-temperature plasma effects on germination of three genotypes of *Arabidopsis thaliana* seeds under osmotic and saline stresses. – *Sci. Rep.-UK* **9**: 8649, 2019.
- Baker N.R.: Chlorophyll fluorescence: a probe of photosynthesis *in vivo*. – *Annu. Rev. Plant Biol.* **59**: 89-113, 2008.
- Bès A., Koo M., Phan T.L. *et al.*: Oxygen plasma etching of hydrocarbon-like polymers: Part II experimental validation. – *Plasma Process. Polym.* **15**: e1800037, 2018.
- Bormashenko E., Grynyov R., Bormashenko Y., Drori E.: Cold

- radiofrequency plasma treatment modifies wettability and germination speed of plant seeds. – *Sci. Rep.-UK* **2**: 741, 2012.
- Brestic M., Zivcak M.: PSII fluorescence techniques for measurement of drought and high temperature stress signal in crop plants: Protocols and applications. – In: Rout G., Das A. (ed.): *Molecular Stress Physiology of Plants*. Pp. 87-131. Springer, India 2013.
- Bussotti F., Gerosa G., Digrado A., Pollastrini M.: Selection of chlorophyll fluorescence parameters as indicators of photosynthetic efficiency in large scale plant ecological studies. – *Ecol. Indic.* **108**: 105686, 2020.
- Chen F.F.: *Introduction to Plasma Physics and Controlled Fusion*. Pp. 490. Springer, Cham 2016.
- Dasan B.G., Boyaci I.H., Mutlu M.: Inactivation of aflatoxigenic fungi (*Aspergillus* spp.) on granular food model, maize, in an atmospheric pressure fluidized bed plasma system. – *Food Control* **70**: 1-8, 2016.
- Dhaya M., Lee S.-Y., Park S.-U.: Using low-pressure plasma for *Carthamus tinctorius* L. seed surface modification. – *Vacuum* **80**: 499-506, 2006.
- Dobrin D., Magureanu M., Mandache N.B., Ionita M.D.: The effect of non-thermal plasma treatment on wheat germination and early growth. – *Innov. Food Sci. Emerg. Technol.* **29**: 255-260, 2015.
- Ehlbeck J., Schnabel U., Polak M. *et al.*: Low temperature atmospheric pressure plasma sources for microbial decontamination. – *J. Phys. D. Appl. Phys.* **44**: 013002, 2011.
- Fahad S., Bajwa A.A., Nazir U. *et al.*: Crop production under drought and heat stress: Plant responses and management options. – *Front. Plant Sci.* **8**: 1147, 2017.
- Ferrero F.: Wettability measurements on plasma treated synthetic fabrics by capillary rise method. – *Polym. Test.* **22**: 571-578, 2003.
- Foyer C.H., Noctor G.: Ascorbate and glutathione: the heart of the redox hub. – *Plant Physiol.* **155**: 2-18, 2011.
- Fridovich I.: Oxygen toxicity: a radical explanation. – *J. Exp. Biol.* **201**: 1203-1209, 1998.
- Gierczik K., Vukušić T., Kovács L. *et al.*: Plasma-activated water to improve the stress tolerance of barley. – *Plasma Process. Polym.* **17**: 1900123, 2020.
- Godic A., Poljšak B., Adamic M., Dahmane R.: The role of antioxidants in skin cancer prevention and treatment. – *Oxid. Med. Cell. Longev.* **2014**: 860479, 2014.
- İlik E., Durmuş Ç., Akan T.: Investigation on optical properties of atmospheric pressure plasma jets of N₂ gas. – *Adyu J. Sci.* **10**: 326-338, 2020.
- Jadoon S., Karim S., Asad M.H.H.B. *et al.*: Anti-aging potential of phytoextract loaded-pharmaceutical creams for human skin cell longevity. – *Oxid. Med. Cell. Longev.* **2015**: 709628, 2015.
- Jiang J., Lu Y., Li J. *et al.*: Effect of seed treatment by cold plasma on the resistance of tomato to *Ralstonia solanacearum* (bacterial wilt). – *PLoS ONE* **9**: e97753, 2014.
- Kabir A.H., Rahman M.M., Das U. *et al.*: Reduction of cadmium toxicity in wheat through plasma technology. – *PLoS ONE* **14**: e0214509, 2019.
- Leti L.I., Gerber I.C., Mihaila I. *et al.*: The modulatory effects of non-thermal plasma on seed's morphology, germination and genetics – a review. – *Plants-Basel* **11**: 2181, 2022.
- Li L., Jiang J., Li J. *et al.*: Effects of cold plasma treatment on seed germination and seedling growth of soybean. – *Sci. Rep.-UK* **41**: 5859, 2014.
- Lichtenthaler H.K.: Vegetation stress: an introduction to the stress concept in plants. – *J. Plant Physiol.* **148**: 4-14, 1996.
- Lichtenthaler H.K., Burkart S.: Photosynthesis and high light stress. – *Bulg. J. Plant Physiol.* **25**: 3-16, 1999.
- Lin S.-P., Khumsupan D., Chou Y.-J. *et al.*: Applications of atmospheric cold plasma in agricultural, medical, and bioprocessing industries. – *Appl. Microbiol. Biot.* **106**: 7737-7750, 2022.
- Malinská H., Pidlisnyuk V., Nebeská D. *et al.*: Physiological response of *Miscanthus × giganteus* to plant growth regulators in nutritionally poor soil. – *Plants-Basel* **9**: 194, 2020.
- Maxwell K., Johnson G.N.: Chlorophyll fluorescence – a practical guide. – *J. Exp. Bot.* **51**: 659-668, 2000.
- Mildažienė V., Aleknavičiūtė V., Žukienė R. *et al.*: Treatment of common sunflower (*Helianthus annuus* L.) seeds with radio-frequency electromagnetic field and cold plasma induces changes in seed phytohormone balance, seedling development and leaf protein expression. – *Sci. Rep.-UK* **9**: 6437, 2019.
- Mildaziene V., Ivankov A., Sera B., Baniulis D.: Biochemical and physiological plant processes affected by seed treatment with non-thermal plasma. – *Plants-Basel* **11**: 856, 2022.
- Miller G., Suzuki N., Ciftci-Yilmaz S., Mittler R.: Reactive oxygen species homeostasis and signalling during drought and salinity stresses. – *Plant Cell Environ.* **33**: 453-467, 2010.
- Mittler R.: Oxidative stress, antioxidants and stress tolerance. – *Trends Plant Sci.* **7**: 405-410, 2002.
- Mittler R., Blumwald E.: Genetic engineering for modern agriculture: challenges and perspectives. – *Annu. Rev. Plant Biol.* **61**: 443-462, 2010.
- Moustakas M., Sperdoui I., Kouina T. *et al.*: Exogenous proline induces soluble sugar accumulation and alleviates drought stress effects on photosystem II functioning of *Arabidopsis thaliana* leaves. – *Plant Growth Regul.* **65**: 315-325, 2011.
- Murchie E.H., Lawson T.: Chlorophyll fluorescence analysis: a guide to good practice and understanding some new applications. – *J. Exp. Bot.* **64**: 3983-3998, 2013.
- Nakai K., Tsuruta D.: What are reactive oxygen species, free radicals, and oxidative stress in skin diseases? – *Int. J. Mol. Sci.* **22**: 10799, 2021.
- Paňka D., Jeske M., Łukanowski A. *et al.*: Can cold plasma be used for boosting plant growth and plant protection in sustainable plant production? – *Agronomy* **12**: 841, 2022.
- Randeniya L.K., de Groot G.J.J.B.: Non-thermal plasma treatment of agricultural seeds for stimulation of germination, removal of surface contamination and other benefits: a review. – *Plasma Process. Polym.* **12**: 608-623, 2015.
- Ranieri P., Sponsel N., Kizer J. *et al.*: Plasma agriculture: Review from the perspective of the plant and its ecosystem. – *Plasma Process. Polym.* **18**: 2000162, 2021.
- Scholtz V., Šerá B., Khun J. *et al.*: Effects of nonthermal plasma on wheat grains and products. – *J. Food Quality* **2019**: 7917825, 2019.
- Šerá B., Gajdová I., Šerý M., Špatenka P.: New physicochemical treatment method of poppy seeds for agriculture and food industries. – *Plasma Sci. Technol.* **15**: 935, 2013.
- Šerá B., Špatenka P., Šerý M. *et al.*: Influence of plasma treatment on wheat and oat germination and early growth. – *IEEE Trans. Plasma Sci.* **38**: 2963-2968, 2010.
- Shelar A., Nile S.H., Singh A.V. *et al.*: Recent advances in nano-enabled seed treatment strategies for sustainable agriculture: challenges, risk assessment, and future perspectives. – *Nano-Micro Lett.* **15**: 54, 2023.
- Shelar A., Singh A.V., Dietrich P. *et al.*: Emerging cold plasma treatment and machine learning prospects for seed priming: a step towards sustainable food production. – *RSC Adv.* **12**: 10467-10488, 2022.
- Shelar A., Singh A.V., Maharjan R.S. *et al.*: Sustainable agriculture through multidisciplinary seed nanoprimer: prospects of opportunities and challenges. – *Cells* **10**: 2428,

- 2021.
- Shibusawa K., Funatsu M.: Radiative characteristics of N₂ first positive band in visible and near-infrared regions for microwave-discharged nitrogen plasma. – T. Jpn. Soc. Aeronaut. S. **62**: 86-92, 2019.
- Sidik M.A.B., Buntat Z., Nawawi Z. *et al.*: Effects of cold plasma treatment on the growth rate of corn and eggplant plants. – In: 2018 International Conference on Electrical Engineering and Computer Science (ICECOS), Pangkal, Indonesia. Pp. 441-446. IEEE, 2018.
- Sivachandiran L., Khacef A.: Enhanced seed germination and plant growth by atmospheric pressure cold air plasma: combined effect of seed and water treatment. – RSC Adv. **7**: 1822-1832, 2017.
- Stirbet A., Govindjee: Chlorophyll *a* fluorescence induction: a personal perspective of the thermal phase, the J-I-P rise. – Photosynth. Res. **113**: 15-61, 2012.
- Stirbet A., Govindjee, Strasser B.J., Strasser R.J.: Chlorophyll *a* fluorescence induction in higher plants: modelling and numerical simulation. – J. Theor. Biol. **193**: 131-151, 1998.
- Strasser R.J., Srivastava A., Govindjee: Polyphasic chlorophyll *a* fluorescence transient in plants and cyanobacteria. – Photochem. Photobiol. **61**: 32-42, 1995.
- Strasser R.J., Tsimilli-Michael M., Srivastava A.: Analysis of the chlorophyll *a* fluorescence transient. – In: Papageorgiou G.C., Govindjee (ed.): Chlorophyll *a* Fluorescence: A Signature of Photosynthesis. Advances in Photosynthesis and Respiration. Pp. 321-362. Springer, Dordrecht 2004.
- Švubová R., Kyzek S., Medvecká V. *et al.*: Novel insight at the effect of cold atmospheric pressure plasma on the activity of enzymes essential for the germination of pea (*Pisum sativum* L. cv. Prophet) seeds. – Plasma Chem. Plasma Process. **40**: 1221-1240, 2020.
- Švubová R., Slováková L., Holubová L. *et al.*: Evaluation of the impact of cold atmospheric pressure plasma on soybean seed germination. – Plants-Basel **10**: 177, 2021.
- Takahashi S., Badger M.R.: Photoprotection in plants: a new light on photosystem II damage. – Trends Plant Sci. **16**: 53-60, 2011.
- Takahashi S., Murata N.: How do environmental stresses accelerate photoinhibition? – Trends Plant Sci. **13**: 178-182, 2008.
- Turner M.: Physics of cold plasma. – In: Misra N.N., Schlüter O.K., Cullen P.J. (ed.): Cold Plasma in Food and Agriculture: Fundamentals and Applications. Pp. 17-51. Academic Press, London 2016.
- Volin J.C., Denes F.S., Young R.A., Park S.M.T.: Modification of seed germination performance through cold plasma chemistry technology. – Crop Sci. **40**: 1706-1718, 2000.
- Whitehead J.C.: The chemistry of cold plasma. – In: Misra N.N., Schlüter O.K., Cullen P.J.: Cold Plasma in Food and Agriculture: Fundamentals and Applications. Pp. 53-81. Academic Press, London 2016.
- Zahoranová A., Hoppanová L., Šimončicová J. *et al.*: Effect of cold atmospheric pressure plasma on maize seeds: enhancement of seedlings growth and surface microorganisms inactivation. – Plasma Chem. Plasma Process. **38**: 969-988, 2018.
- Zarco-Tejada P.J., González-Dugo V., Berni J.A.J.: Fluorescence, temperature and narrow-band indices acquired from a UAV platform for water stress detection using a micro-hyperspectral imager and a thermal camera. – Remote Sens. Environ. **117**: 322-337, 2012.
- Zhang R., Sharkey T.D.: Photosynthetic electron transport and proton flux under moderate heat stress. – Photosynth. Res. **100**: 29-43, 2009.
- Zukiene R., Nauciene Z., Januskaitiene I. *et al.*: Dielectric barrier discharge plasma treatment-induced changes in sunflower seed germination, phytohormone balance, and seedling growth. – Appl. Phys. Express **12**: 126003, 2019.
- Živčák M., Brestič M., Olšovská K., Slamka P.: Performance index as a sensitive indicator of water stress in *Triticum aestivum* L. – Plant Soil Environ. **54**: 133-139, 2008.