

HOSTED BY



Contents lists available at ScienceDirect

International Journal of Nursing Sciences

journal homepage: <http://www.elsevier.com/journals/international-journal-of-nursing-sciences/2352-0132>

Reliability and validity of the Chinese version of the Readiness for Hospital Discharge Scale—Parent Form in parents of preterm infants

Yongfeng Chen, MSN, RN^a, Jinbing Bai, Ph.D., RN^{b,*}^a The People's Hospital of Guangxi Zhuang Autonomous Region, Nanning, China^b Nell Hodgson Woodruff School of Nursing, Emory University, Atlanta, GA, United States

ARTICLE INFO

Article history:

Received 31 August 2016

Accepted 23 January 2017

Available online 9 February 2017

Keywords:

Parent

Preterm infant

Neonatal intensive care units

Readiness for hospital discharge

Scale—Parent Form

Psychometric property

Instrument translation

ABSTRACT

Background: The Readiness for Hospital Discharge Scale (RHDS)—Parent Form shows satisfactory reliability and validity to assess the readiness of parents to take care of their children discharged from hospitals in Western countries. However, the reliability and validity of this instrument has not been evaluated in Chinese populations.

Objectives: Evaluate the psychometric features of the RHDS—Parent Form among Chinese parents of preterm infants.

Methods: The RHDS—Parent Form was translated into a Chinese version following an international instrument translation guideline. A total of 168 parents with preterm infants were recruited from the neonatal intensive care units of two tertiary-level hospitals in China. The internal consistency of this measure was assessed using the Cronbach's α coefficient; confirmatory factor analysis was conducted to evaluate the construct validity; and Pearson correlation coefficient was used to report the convergent validity.

Results: The Chinese version of RHDS (C-RHDS)—Parent Form included 22 items with 4 subscales, accounting for 56.71% of the total variance. The C-RHDS—Parent Form and its subscales showed good reliability (Cronbach's α values 0.78–0.92). This measure and its subscales showed positive correlations with the score of Quality of Discharge Teaching Scale.

Conclusion: The factor structure of C-RHDS—Parent Form is partially consistent with the original English version. Future studies are needed to explore the factors within this measure before it is widely used in Chinese clinical care settings.

© 2017 Chinese Nursing Association. Production and hosting by Elsevier B.V. This is an open access article under the CC BY-NC-ND license (<http://creativecommons.org/licenses/by-nc-nd/4.0/>).

1. Introduction

The World Health Organization (WHO) reports that worldwide, one out of 10 infants are born prematurely each year [1]. China has the largest number of preterm infants in the world. Compared to infants born maturely, preterm infants are more susceptible to various health issues [2] and require additional health care in the neonatal intensive care units (NICUs) [3]. Their discharge from the NICUs may lead to a great deal of vulnerability for them and their parents due to shifts in health conditions, family relationships, and parents' ability to follow care plans [4]. Parents may question their

ability to engage in the full responsibility of caring for their premature children for the first time without the presence of health care providers [5]. Discharge planning has been reported as a major means for creating a smooth transition from health care settings to the home environment [6] and for preventing hospital readmission [7]. Assessing patient-reported readiness for hospital discharge is regarded as an important part of the hospital discharge process and a potential predictor of post-discharge outcomes [8]. Preterm infants cannot report their readiness, and their developmental stage might contribute to parenting difficulties. Because parents are the primary caregivers of preterm infants after discharge, it is important to assess parents' readiness before their preterm infants' release from the hospital to ensure infant safety and increase health care outcomes at home.

At present, a premature infant's readiness for discharge from the hospital is primarily determined by a set of clinical criteria, as judged by clinicians, without considering parent-reported

* Corresponding author. Nell Hodgson Woodruff School of Nursing, Emory University, Atlanta, GA 30322, United States.

E-mail address: jinbing.bai@emory.edu (J. Bai).

Peer review under responsibility of Chinese Nursing Association.

readiness. Studies have found that perceptions of readiness for discharge differ between family members and health care providers [9]. A very limited body of literature exists regarding preparing parents for the discharge of their preterm infants from hospitals. A critical step in improving continuity of care is to develop a reliable and valid instrument that can evaluate parents' readiness for their preterm infants' discharge from NICUs so that necessary interventions can be developed to meet parental needs.

Several measures have been developed to assess patients' or caregivers' readiness for hospital discharge, including the PREPARED Questionnaire [10], the Care Transitions Measure (CTM) [11], the Readiness for Discharge Questionnaire (RDQ) [12], the Post Anesthetic Discharge Scoring System (PADSS) [13], and the Readiness for Hospital Discharge Scale (RHDS)–Parent Form [14,15]. The PREPARED Questionnaire was developed to assess the quality of planning for hospital discharge for elders and their caregivers [10]; the CTM was developed to assess the quality of care transition from patients' perspective (≥ 18 years old) [11]. Both the PREPARED Questionnaire and the CTM are completed at home by adult patients and/or their caregivers after hospital discharge [10,11]. The RDQ was developed to assess discharge readiness for patients with schizophrenia [12] and the PADSS was created to assess post-anesthetic recovery [13]. Both the RDQ and the PADSS are completed by health care providers on the day of patients' discharge [12,13]. All four of these measures have good reliability and validity [10–13], but none of them was designed to assess parental readiness for discharge of their hospitalized children.

The RHDS–Parent Form was developed to measure parent-perceived readiness for hospital discharge of children (0–18 years old) on the day of discharge [14,15]. This scale has 29 items, which are covered by five subscales: child personal status, parent personal status, knowledge, coping ability, and expected support [15]. This measure has adequate psychometric properties and has been widely used in Western countries [14,15]. Assessing parental readiness before infants' discharge can provide insights regarding how to promote a smooth transition from hospital to home care and improve health care outcomes at home. Studies have reported that a higher quality of discharge teaching can heighten parents' readiness for hospital discharge and lead to fewer parent coping difficulties at home [16]. As the only available measure to assess parental readiness on the day of infants' discharge, the RHDS–Parent Form has not been evaluated for use in Chinese populations. The purpose of this study was to evaluate the reliability and validity of the RHDS–Parent Form among parents of preterm infants in China.

2. Methods

2.1. Participants

A convenience sampling method was used to select parents with preterm infants who were hospitalized in the NICUs of two tertiary hospitals in Wuhan, China. Eligible parents were required to be ages ≥ 18 years and to have finished grade 8 or above. In addition, they had to be identified as parents who would become primary caregivers of preterm infants discharged to home. Parents were excluded if their preterm infants needed surgery, were diagnosed with congenital abnormalities, were abandoned, readmitted, or deceased.

In the instrument development and testing process, approximately 5–10 samples are needed per item and the needed samples per item decrease with an increasing sample size [17]. In this study, the estimated sample size should range between 145 and 290 with respect to a total of 29 items in the RHDS–Parent Form. A total of 168 parents were recruited for this study.

2.2. Instrument

2.2.1. RHDS–Parent Form

The 29-item RHDS–Parent Form was originally built to measure parental readiness for hospitalized children's (0–18 years old) discharge [14,15]. These items are grouped into five subscales: parent personal status, child personal status, knowledge, coping ability, and expected support. Child and parent personal status describes, respectively, both a child's and a parent's physical-emotional state before discharge; knowledge represents parental perceptions of information needed to address their concerns and answer their questions after discharge; coping ability refers to parent-perceived abilities to take care of their children at home; and expected support means the emotional and instrumental support that should be available after discharge. Each item uses an 11-point response option with anchors “not at all” at the beginning and “totally” at the end. The total score ranges from 0 to 290. A higher total score indicates a better parent readiness for hospital discharge. Cronbach's α values ranged from 0.70 to 0.86 for the total scale and its subscales [15]. The confirmatory factor analysis (CFA) has demonstrated satisfactory psychometric status [i.e., Lisrel Goodness of Fit Index (GFI) = 0.79; standardized root mean residuals (SRMR) = 0.10; root mean square error of approximation (RMSEA) = 0.10; and standardized absolute residuals = 0.07] [14].

2.2.2. Quality of Discharge Teaching Scale (QDTS)–Parent Form

The QDTS–Parent Form was developed to assess how parents perceived the teaching ability of their children's nurses [15]. This instrument consists of 18 items under 2 subscales: content received subscale and delivery subscale. The 6-item content received subscale addresses the quality of the education received for discharge preparation, and the 12-item delivery subscale assesses the nurses' skills when presenting discharge information. Each item uses an 11-point response option with anchors “not at all” at the beginning and “totally” at the end. The total score of the QDTS–Parent Form ranges from 0 to 180. A higher total score indicates better overall discharge instruction. The Cronbach's α coefficient is 0.88 for the total scale and 0.78 and 0.88 for content received and content delivery subscales, respectively [15]. There is no Chinese version of QDTS–Parent Form available. It was translated into Chinese along with the RHDS–Parent Form according to the instrument translation guideline [18]. In this study, the Cronbach's α coefficient was 0.82 for the total scale and 0.86 and 0.88 respectively for the content received and content delivery subscales.

2.3. Instrument translation and pilot test procedure

2.3.1. Translation

After obtaining permission to translate and evaluate the RHDS–Parent Form from the original developer, the transcultural adaptation of the RHDS–Parent Form was conducted based on a standard translation guideline recommended by Wild et al. [18]. Two bilingual nursing researchers who had clinical and research experience but were not familiar with the original RHDS–Parent Form independently translated the English version of RHDS–Parent Form into two separate Chinese versions (forward translation). A forward-translated RHDS–Parent Form was finalized after both forward-translators reached an agreement. Two other bilingual experts not familiar with the original measure independently translated the forward-translated RHDS–Parent Form back to two separate English versions (back-translation). One final back-translated RHDS–Parent Form was developed after a consensus was reached between both back-translators. Finally, the proof-reading of the back-translated version (in English) of RHDS–Parent Form was checked against the original English instrument by the

original developer. Differences between these two English versions of RHDS–Parent Form were discussed and modifications were made until no further discrepancies existed.

2.3.2. Pilot test

The first pilot test was performed to assess item readability and comprehensibility. A sample of 12 parents who met the study eligibility criteria were asked to complete the translated version of RHDS–Parent Form. Unreadable items were rephrased. Another 12 participants were recruited for the second pilot test. The second pilot test showed that all participants understood items easily and supported the readability and comprehensibility of the Chinese version of RHDS (C-RHDS)–Parent Form.

2.4. Data collection

Data were collected by the first author between October 2011 and June 2012. This study was introduced to eligible parents who had at least one child undergoing treatment in an NICU. Written informed consent was obtained if parents showed interest in participating in the study. All participants were asked to complete the demographic data, the C-RHDS–Parent Form, and the QDTS–Parent Form on the day of preterm infants' discharge from NICUs. All these measures took about 10–15 min to complete.

2.5. Ethical consideration

Approval was obtained from the Institutional Review Boards (IRBs) of one university and two relevant hospitals. All the collected data were confidentially secured, and the eligible parents were told that their participation was voluntary and that leaving the study at any time would not affect their children's treatment and care.

2.6. Data analysis

Descriptive statistics were conducted to summarize the demographic information of participants. Reliability of the C-RHDS–Parent Form was presented using the Cronbach's α coefficient. The CFA was conducted to report the construct validity of the scale. Before initiating the factor analysis, we examined the adequacy of the data using the Kaiser-Meyer-Olkin (KMO) and Bartlett's test of sphericity. We then conducted the principal axis factoring approach with an oblique rotation to test the structure of the C-RHDS–Parent Form. The number of the factors in this measure was decided based on the scree plot, an eigenvalue above 1.0, and the percentage of explained variance [19]. Each item of a factor has to have a loading ≥ 0.3 and a cross-loading ≥ 0.15 [20,21]. The convergent validity of this scale was reported by the correlations between the quality of discharge teaching and parent readiness for discharge. All the data were analyzed using SPSS 16.0 (SPSS Inc., Chicago, IL, USA). A p -value < 0.05 indicated a level of statistical significance.

3. Results

3.1. Participants

A total of 168 parents were recruited for this study, and 150 (89.29%) parents completed it. Eighteen participants were excluded due to their infants' health conditions and parents' time conflicts. Among 150 parents, 73.3% of them were fathers. Parental ages ranged from 19 to 41 years (mean = 29.6). More than 60% of these parents had completed middle/high school and 39.3% college or higher education level. Among the preterm infants, the average gestational age was 34.23 weeks, and 51.30% of them were born

vaginally; the mean birth weight was 2.20 kg and mean age was 18.81 days. The preterm infants had an average of 14.9 days length of stay in the NICUs (range = 3–60 days).

3.2. Confirmatory factor analysis

The KMO value of 0.86 and the statistical significance of Bartlett's test suggested the adequacy of factor analysis in this study. Based on the Principal Component Analysis method with an Oblimin rotation, we performed the CFA to evaluate the adequacy of using the RHDS–Parent Form in the Chinese NICUs. There are twenty-four items representing 4 domains with 56.71% variance explained in this study. Five items were deleted because of either lower loadings than 0.3 (item 6a) or crossover loading lower than 0.15 (4 items 2a, 7b, 8b and 19). Table 1 describes the detailed factor loading, eigenvalue, and variance explained for each factor in the C-RHDS–Parent Form.

The AMOS was used to test this CFA model with the following model fit indices examined: the Chi-Square test, Bentler Comparative Fit Index (CFI), Tucker-Lewis (non-normed fit) Index (TLI), SRMR, and RMSEA [22]. According to the model tests, two additional items were deleted (items 18 and 20), leading to the 22-item C-RHDS–Parent Form (Fig. 1). Table 2 compares the model fit indices for the 24-item C-RHDS–Parent Form, 22-item C-RHDS–Parent Form, and the original 29-item RHDS–Parent Form.

3.3. Internal consistency

The 22-item C-RHDS–Parent Form was chosen to assess parent readiness for the premature infant's hospital discharge. The Cronbach's α values were 0.91 for the total scale, 0.92, 0.84, 0.78, and 0.82 for knowledge, physical-emotional status, expected support, and pain status, respectively (Table 3).

3.4. Convergent validity

The associations between the quality of discharge teaching and parent readiness for hospital discharge were reported using Pearson product–moment correlation. Table 3 shows that content received, content delivery, and the total score of QDTS–Parent Form were positively associated with the subscales and total scale of the C-RHDS–Parent Form. Our results support our hypothesis that parents receiving higher quality of discharge teaching will have better discharge readiness.

4. Discussion

Findings of the CFA in this study revealed that the C-RHDS–Parent Form was comprised of 22 items that can be grouped into 4 subscales and that 7 items were deleted from the original RHDS–Parent Form. The subscales of knowledge and expected support were completely consistent with the original scale. These similarities can be explained as follows: First, with the development of Chinese medical care system, the average length of hospital stays has decreased in recent years. To reduce patients' hospital readmission rate, improving patients' discharge readiness and ensuring safe transitions has become common practice in China. Hospitals are advocating the preparation of children and families for discharge via discharge education and specific follow-up plans. Second, the extensive level of communication between Chinese nurses, researchers, educators and their counterparts from Western countries including the United States are significantly impacting the clinical care Chinese preterm infants receive. Third, with the development of the Chinese economy, more parents and families are learning ways to take care of premature infants, including the

Table 1
Confirmatory factor analysis of the C-RHDS–Parent Form.

Item	Factor Loading				Eigenvalue	Explained Variance, %		
	Factor 1	Factor 2	Factor 3	Factor 4				
Item 17	0.89				10.40	35.88		
Item 15	0.81							
Item 16	0.81							
Item 12	0.76							
Item 11	0.75							
Item 13	0.75							
Item 10	0.69							
Item 9	0.64							
Item 20	0.58							
Item 18	0.53							
Item 14	0.49							
Item 7a		0.80					2.70	9.30
Item 5a		0.73						
Item 8a		0.73						
Item 5b		0.63						
Item 4b		0.62						
Item 2b		0.58						
Item 4a		0.56						
Item 22			0.90		1.74	6.00		
Item 23			0.71					
Item 21			0.62					
Item 24			0.58					
Item 3b				0.70	1.60	5.53		
Item 3a				0.70				

C-RHDS = Chinese version of the Readiness for Hospital Discharge Scale.

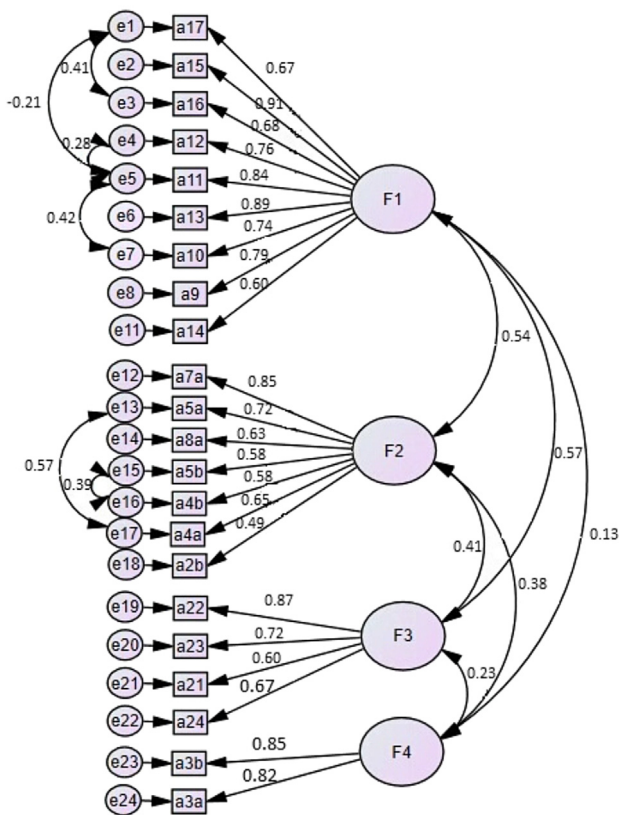

Fig. 1. Structure of the Chinese version of the RHDS–Parent Form.

discharge education many Chinese hospitals now offer.

Two factors of the C-RHDS–Parent Form differ from the original RHDS–Parent Form. Two items in the subscale of personal status in

Table 2

Model fit indices for the confirmatory factor analysis of the C-RHDS – Parent Form.

Model	χ^2/df	RMSEA	SRMR	CFI (GFI)	TLI
22-Item C-RHDS–Parent Form	1.91	0.078	0.066	0.91	0.90
24-Item C-RHDS–Parent Form	2.09	0.085	0.07	0.88	0.86
29-Item original RHDS–Parent Form	–	0.10	0.10	0.79	–

RMSEA = the root mean square error of approximation; SRMR=Standardized Root Mean Square Residual; CFI = the Bentler Comparative Fit Index; TLI = the Tucker-Lewis (non-normed fit) Index.

the original scale were formulated into a separate factor (i.e., pain status). The factor of personal status in the original scale was loaded in two structural factors in the C-RHDS–Parent Form, labeled as physical-emotional status and pain status. This may be attributed to the fact that pain is a very common reason for a physician's consultation [23]. Pain can decrease patients' quality of life as well as their physical, emotional, social function and is an important component of a person's "personal status." In this study, most parents (60.7%) had only finished middle school or high school and most did not have a medical background. Parents may treat pain as the major sign of disease and may not be confident enough to care for their preterm infants after discharge, especially when they feel uncomfortable themselves. Therefore, the level of pain felt by infants or parents becomes a major priority compared with other discharge preparation matters. We suggest further identifying the structure factors within this measure and attempting to understand their meanings using qualitative inquiries.

Conversely, one subscale (i.e., coping ability) as defined by Weiss et al. [15], was excluded from the C-RHDS–Parent Form. This change might be explained by differing NICU visitation policies. In the United States, for instance, parents are allowed to stay with their preterm infants every day. During the visitation period, parents can develop a relationship with NICU health care providers, receive information and education concerning their preterm infants, and learn from the staff how to provide infant care [24]. However, based on the policies of the two hospitals participating in this study, parents received reports from their children's doctors

Table 3
The internal consistency and convergent validity of the C-RHDS–Parent Form.

The C-RHDS–Parent Form	Cronbach's α	Content received	Content delivery	Total QDTS–Parent Form
Factor 1: Knowledge	0.92	0.57 ^a	0.58 ^a	0.62 ^a
Factor 2: Physical–emotional status	0.84	0.24 ^b	0.41 ^a	0.37 ^a
Factor 3: Expected support	0.78	0.37 ^a	0.45 ^a	0.43 ^a
Factor 4: Pain status	0.82	0.19 ^c	0.14	0.18 ^c
Total C-RHDS–Parent Form	0.91	0.53 ^a	0.57 ^a	0.60 ^a

QDTS = Quality of Discharge Teaching Scale; ^a $P < 0.001$, ^b $P < 0.01$, ^c $P < 0.05$.

2–3 times per week and were prohibited from entering the NICUs. This scarcity of interaction between parents and clinicians may lead to an absence of substantive communication between parents, infants, and health caregivers. In Chinese hospitals, parents do not have the opportunity to provide care for their preterm infants under the supervision of health care providers; this omission may prevent parents from understanding the scope of the challenges they may face at home after discharge. The meaning of coping abilities should be specifically investigated in Chinese NICUs. In this study, the mean age of infants was 19 days after birth. Most mothers were still under confinement following childbirth and did not show up on the day of discharge; as a result, more fathers were enrolled in this study. However, fathers generally may not be the primary caregivers for preterm infants after discharge. Future work should evaluate the use of this measure with the mothers of premature infants hospitalized in Chinese NICUs.

Regarding the reliability analysis of the 22-item C-RHDS–Parent Form, we found that the Cronbach's α coefficient was 0.91 for the total scale, with a range of 0.78–0.92 for the subscales, being consistent with the results of the original scale [15] and suggesting excellent reliability of the 22-item C-RHDS–Parent Form with Cronbach's α value exceed 0.80 [25]. In addition, the correlations between the quality of discharge teaching and the C-RHDS–Parent Form supported the construct and relationships proposed by the Transition Theory [4] and the conceptual work of Weiss [14].

This study has several limitations. First, we used a convenience sample limited to parents of preterm infants hospitalized in the NICUs of two tertiary hospitals in one large Chinese city; this method may have restricted our study's representativeness, thus limiting the generalizability of our study findings. Future studies with a larger sample of parents whose children are hospitalized in different clinical care centers are needed. Second, because the content validity of C-RHDS–Parent Form was not evaluated in this work, future studies exploring this instrument's content validity are needed. Nevertheless, our pilot tests showed appropriate readability of this scale for use with parents of preterm infants. Third, there was no discharge teaching quality instrument available for Chinese parents of premature infants. The QDTS–Parent Form was transculturally translated and used to evaluate the convergent validity of the C-RHDS–Parent Form. The translation process was conducted along with the C-RHDS–Parent Form in a rigorous fashion to minimize potential bias.

5. Conclusion

The C-RHDS–Parent Form is a 22-item scale with 4 subscales: physical–emotional status, pain status, knowledge, and expected support. The factor structure of the C-RHDS–Parent Form showed partial consistency with its original version, indicating that parental readiness for premature infants' discharge may vary with different cultures and genders. Future studies should explore the factor structure within this scale among mothers before the C-RHDS–Parent Form is widely applied in Chinese clinical care settings.

Funding

This research did not receive any specific grant from funding agencies in the public, commercial, or not-for-profit sectors.

Author contributions

Chen and Bai designed the study. Chen recruited participating hospitals and parents, collected data and drafted the manuscript. Bai analyzed the data and contributed substantially to manuscript revision.

Conflict of interest statement

None.

Acknowledgments

The authors thank all the parents who participated in this study. The authors thank Rebecca Meador from Emory University for editing this manuscript.

Appendix A. Supplementary data

Supplementary data related to this article can be found at <http://dx.doi.org/10.1016/j.ijnss.2017.01.009>.

References

- [1] World Health Organization. World health statistics. Available at: 2013. http://apps.who.int/iris/bitstream/10665/81965/1/9789241564588_eng.pdf?ua=1.
- [2] Kelly M. Primary care issues for the healthy premature infant. *J Pediatr Health Care* 2006;20(5):293–9.
- [3] Grisaru-Granovsky S, Reichman B, Lerner-Geva L, Boyko V, Hammerman C, Samueloff A, et al. Mortality and morbidity in preterm small-for-gestational-age infants: a population-based study. *150 Am J Obstet Gynecol* 2012;206(2):e1–7.
- [4] Meleis AL, Sawyer LM, Im EQ, Messias DK, Schumacher K. Experiencing transitions: an emerging middle-range theory. *Adv Nurs Sci* 2000;23(1):12–28.
- [5] Jefferies AL. Going home: facilitating discharge of the preterm infant. *Paediatr Child Health* 2014;19(1):31–42.
- [6] Lin SC, Cheng SJ, Shih SC, Chang WL, Chu CH, Tjung JJ. The past, present, and future of discharge planning in Taiwan. *Int J Gerontol* 2013;7(2):65–9.
- [7] Labson MC. Innovative and successful approaches to improving care transitions from hospital to home. *Home Healthc Now* 2015;33(2):88–95.
- [8] Howard-Anderson J, Lonowski S, Vangala S, Tseng C, Busuttill A, Afsarmanesh N. Readmissions in the era of patient engagement. *JAMA Intern Med* 2014;174(11):1870–2.
- [9] Smith VC, Young S, Pursley DM, McMormick MC, Zupancic JAF. Are families prepared for discharge from the NICU? *J Perinatol* 2009;29(9):623–9.
- [10] Grimmer K, Moss J. The development, validity and application of a new instrument to assess the quality of discharge planning activities from the community perspective. *Int J Qual Health Care* 2001;13(2):109–16.
- [11] Coleman EA, Mahoney E, Parry C. Assessing the quality of preparation for posthospital care from the patient's perspective. *Med Care* 2005;43(3):246–55.
- [12] Potkin SG, Gharabawi GM, Greenspan AJ, Rupnow MFT, Kosik-Gonzalez C, Remington G, et al. Psychometric evaluation of the readiness for discharge questionnaire. *Schizophr Res* 2005;80(2–3):203–12.
- [13] Ead H. From Aldrete to PADSS: reviewing discharge criteria after ambulatory surgery. *J Perianesth Nurs* 2006;21(4):259–67.

- [14] Weiss M, Piacentine L. Psychometric properties of the readiness for hospital discharge scale. *J Nurs Meas* 2006;14(3):163–80.
- [15] Weiss M, Johnson NL, Malin S, Jerofke T, Lang C, Sherhurne E. Readiness for discharge in parents of hospitalized children. *J Pediatr Nurs* 2008;23(4):282–95.
- [16] Smith VC, Dukhovny D, Zupancic JAF, Gates HB, Pursley DM. Neonatal intensive care unit discharge preparedness: primary care implications. *Clin Pediatr* 2012;51(5):454–61.
- [17] DeVellis RF. *Scale development: theory and applications*. third ed. Newbury Park: Sage Publications; 2012.
- [18] Wild D, Grove A, Maitin M, Eremenco S, McElroy S, Verjee-Lorenz A, et al. Principles of good practice for the translation and cultural adaptation process for the Patient-Reported Outcomes (PRO) measures: report of the ISPOR task force for translation and cultural adaptation. *Value Health* 2005;8(2):94–104.
- [19] Pett MA, Lackey NR, Sullivan JJ. *Making sense of factor analysis: the use of factor analysis for instrument development in health care research*. Thousand Oaks: Sage Publications; 2003.
- [20] Kline P. *The handbook of psychological testing*. 2th ed. London: Routledge; 2000.
- [21] Polit DE, Beck CT. *Nursing research: principles and methods*. seventh ed. Philadelphia: Lippincott Williams and Wilkins; 2004.
- [22] Hooper D, Coughlan J, Mullen M. Structural equation modelling: guidelines for determining model fit. *Electron J Bus Res Methods* 2008;6(1):53–60.
- [23] Debono DJ, Hoeksema LJ, Hobbs RD. Caring for patients with chronic pain: pearls and pitfalls. *J Am Osteopath Assoc* 2013;113(8):620–7.
- [24] Griffin JB, Pickler RH. Hospital-to-home transition of mothers of premature infants. *MCN Am J Matern Child Nurs* 2011;36(4):252–7.
- [25] Polit DF, Hunger BP. *Nursing research: principles and methods*. sixth ed. Philadelphia, JB: Lippincott; 1999.