

# BMJ Open Development and psychometric testing of a Learning Behaviour Questionnaire among Chinese undergraduate nursing students

Yifan Wu,<sup>1</sup> Li Qi,<sup>2</sup> Yu Liu,<sup>1</sup> Xinyi Hao,<sup>1</sup> Shuang Zang <sup>1</sup>

**To cite:** Wu Y, Qi L, Liu Y, *et al.* Development and psychometric testing of a Learning Behaviour Questionnaire among Chinese undergraduate nursing students. *BMJ Open* 2021;**11**:e043711. doi:10.1136/bmjopen-2020-043711

► Prepublication history and additional online supplemental material for this paper are available online. To view these files, please visit the journal online (<http://dx.doi.org/10.1136/bmjopen-2020-043711>).

Received 11 August 2020  
Accepted 26 May 2021



© Author(s) (or their employer(s)) 2021. Re-use permitted under CC BY-NC. No commercial re-use. See rights and permissions. Published by BMJ.

<sup>1</sup>School of Nursing, China Medical University, Shenyang, Liaoning, China

<sup>2</sup>School of Nursing, Qiqihar Medical University, Qiqihar, Heilongjiang, China

## Correspondence to

Associate Professor Shuang Zang; [zangshuang@cmu.edu.cn](mailto:zangshuang@cmu.edu.cn)

## ABSTRACT

**Objective** This study aimed to develop and validate a new Learning Behaviour Questionnaire (LBQ) for the undergraduate nursing students.

**Study design** This study was performed in two phases. Phase 1 of the study focused on questionnaire development to create a pool of items, while phase 2 focused on validity and reliability testing.

**Methods** Semistructured interviews were used to explore nursing undergraduates' perception of learning behaviour. A two-round modified Delphi method was used to test content validity and quantify the degree of consistency in questionnaire items. An item analysis, an exploratory factor analysis (EFA), a confirmatory factor analysis (CFA) and an internal consistency reliability check were conducted. Criterion-related validity was demonstrated through correlations with Self-Regulated Learning Scale for Undergraduates (SRLS-U). A sample of 114 nursing students was evaluated in test–retest reliability to confirm stability.

**Results** The final LBQ consisted of four factors for the 19-item questionnaire with a 5-point rating from '1' (Fully disagree) to '5' (fully agree). The content validity was 0.890. EFA revealed the presence of four factors, including 'strategy', 'attitude', 'motivation' and 'degree of satisfaction'. The CFA indicated good fit indexes for the proposed model ( $\chi^2/df=1.866$ , root mean square residual=0.037, comparative fit index =0.950, goodness-of-fit index =0.929, Tucker-Lewis index=0.941, adjusted goodness-of-fit index=0.907 and root mean square error of approximation=0.049). The LBQ correlated significantly with SRLS-U subscales ( $r=0.742-0.837$ ,  $p<0.01$ ). The Cronbach's alpha coefficient of the whole questionnaire was 0.936, while the Cronbach's alphas of the four factors were 0.828, 0.826, 0.804 and 0.805, respectively. The test–retest reliabilities of the four factors were 0.886, 0.904, 0.852 and 0.875, respectively.

**Conclusion** The validity and reliability of the LBQ were satisfying. The LBQ is a short, well-developed questionnaire that can serve as a generic assessment tool for measuring learning behaviour for Chinese undergraduate nursing students. Cite Now

## INTRODUCTION

Rapid economic growth and comprehensive healthcare changes worldwide have given

## Strengths and limitations of this study

- This study developed a comprehensive questionnaire to quantify the learning behaviour from the perspective of nursing undergraduates.
- Qualitative and quantitative methods were involved in item selection.
- The evaluation of learning behaviour for nursing undergraduates guided teachers to realise teaching effects dynamic characteristics more clearly and provided an important basis to adjust teaching-learning processes in time.
- The questionnaire may lack cultural adjustments in different cultural backgrounds to explore personal learning behaviour.
- The universal adaptability of the questionnaire needs to be further determined when applied to nursing students with other educational levels.

rise to a growing demand for more nurses with higher professional qualifications and highlights the need for a growing nursing industry.<sup>1</sup> As the basis and an important component of training of higher nursing skills, nursing undergraduate education plays a decisive role in the development of the nursing specialty. Professional knowledge, clinical skills and communication ability are the necessary professional abilities of nursing undergraduates. To possess or improve these abilities, good learning behaviour is a decisive factor.<sup>2</sup> Learning behaviour is an unusually stable practice pattern and once cultivated, it becomes resistant to change.<sup>3</sup> Therefore, establishing good learning behaviour is conducive to improving learning efficiency and learning effect long term.<sup>4</sup> For nursing undergraduates, good learning behaviour is of great significance to the development of the nursing discipline and improvement of service quality in the future.

Although learning behaviour is a frequently mentioned word, its connotation has not been precisely defined in academia circles, and



most studies have given a definition of learning behaviour aiming at its research purposes. Schweder and Raufelder regarded learning behaviour as the reaction or action of students in the whole learning process, which included learning habits, learning interests, learning strategies, etc.<sup>5</sup> There were also scholars who describe students' learning behaviour as their individual characteristics in the process of acquiring and applying knowledge, which were different in different learning stages.<sup>6</sup> For nursing students, the occurrence and development of learning behaviour were paid more attention and were considered as the result of interaction between students and the environment.<sup>7</sup> Based on the above description, we defined learning behaviour as the form and method adopted by in the theoretical and practical learning under the given environment. It was the comprehensive behaviour embodiment of learners' emotions, attitudes and satisfaction. Good learning behaviour enables nursing undergraduates to expand their knowledge, improve their learning quality, remain flexible and receptive to change, and play an effective role in clinical services and constantly changing education environment.<sup>8</sup>

Most nursing education programmes in China were based on independent professional teaching, while the clinical practice system also had the shortcoming of untimely feedback, which led to a lack of ability to actively acquire knowledge for nursing students compared with western students.<sup>9</sup> As a result, most of them can hardly adjust their learning strategies to acquire capacity according to their learning ability and motivation. Numerous medical schools all over the world pay more attention to the interpenetration of multidisciplinary nursing courses, the diversity of nursing teaching methods, and the gradual and timely curriculum feedback of nursing clinical practice. The teaching methods which were beneficial to cultivating nursing students' learning autonomy had been developed in Sweden, Germany and many other countries.<sup>10</sup> It is of great significance to measure students' learning behaviour as early as possible in order to carry out educational reform and promote the ability training for nursing students.<sup>11</sup>

Typically, quantitative data about learning behaviour may be obtained using surveys, examinations, standardised observations, etc, while qualitative data may be gathered by oral evaluation, semistructured interviews, etc. Because it is easy and objective to collect data using a questionnaire, some scholars have developed and validated questionnaires to evaluate learning. Roces Montero *et al* developed a learning scale centred on motivation and strategy, which was widely used. However, the structure of the scale only included some learning behaviours, which cannot fully evaluate the whole learning behaviours, such as the change of learning attitude.<sup>12</sup> Cheng *et al* developed and validated an instrument called 'Self-Directed Learning Instrument', which was evaluated from four domains: learning motivation, planning and implementation, self-monitoring and interpersonal communication according to self-directed learning. The instrument highlighted

the importance of individual initiative, thus ignoring the feedback evaluation of learning behaviour, such as learning satisfaction.<sup>13</sup> There were also many learning-related scales, such as the Readiness for Interprofessional Learning Scale, Social-Emotional Learning Competencies Scale, Learning Style Inventory and others.<sup>14-16</sup> Even in China, there were many related questionnaires of the Chinese version, such as the Questionnaire of Nursing Students' Learning Attitude to evaluate nursing students' learning attitude, Learning Motivation Questionnaire and Learning Satisfaction Scale to evaluate the learning-related situation of college students. Nevertheless, these scales were only used to measure some specific directions like learning readiness or learning style. They were unsuitable for evaluating a series of comprehensive, complex and exploratory behaviours in the learning process. The questionnaire developed in this study considered the factors such as learning attitude and learning motivation of nursing students as a whole and further evaluated learning behaviour comprehensively. Furthermore, as the direct implementer of clinical treatment and nursing measures, nursing students were required to have a high level of professionalism and knowledge, which was also directly related to the treatment of diseases and the rehabilitation of patients. Consequently, it is very critical to develop and validate the learning behaviour evaluation tools for nursing undergraduates.

Due to the lack of a comprehensive evaluation tool for studying learning behaviour, some studies used a series of instruments to measure learning behaviour.<sup>17 18</sup> Thus, a standardised and simple Learning Behaviour Questionnaire (LBQ) is needed to evaluate undergraduate nursing students. We developed and validated questionnaire on learning behaviour of nursing undergraduates, aiming at promoting the further development of nursing education evaluation and providing useful information for adjusting undesirable learning behaviours and emotions.

## METHODS

### Study design

This study was performed in two phases (figure 1). Phase 1 of the study focused on questionnaire development to create a pool of items, while phase 2 focused on validity and reliability testing.

### Phase 1: questionnaire development

#### Develop preliminary questions

Cognitive learning theory holds that the key to learning lies in the formation and change of learners' internal psychological structure. Learning is an active process and mainly depends on the original cognitive structure and external stimulation.<sup>19 20</sup> The original cognitive structure, which includes knowledge, strategy, attitude, perception and response, is an interactive organic whole. According to the metacognitive theory proposed by Flavell, the process of learners' active reflection and processing on cognitive activities is a kind of self-awareness and

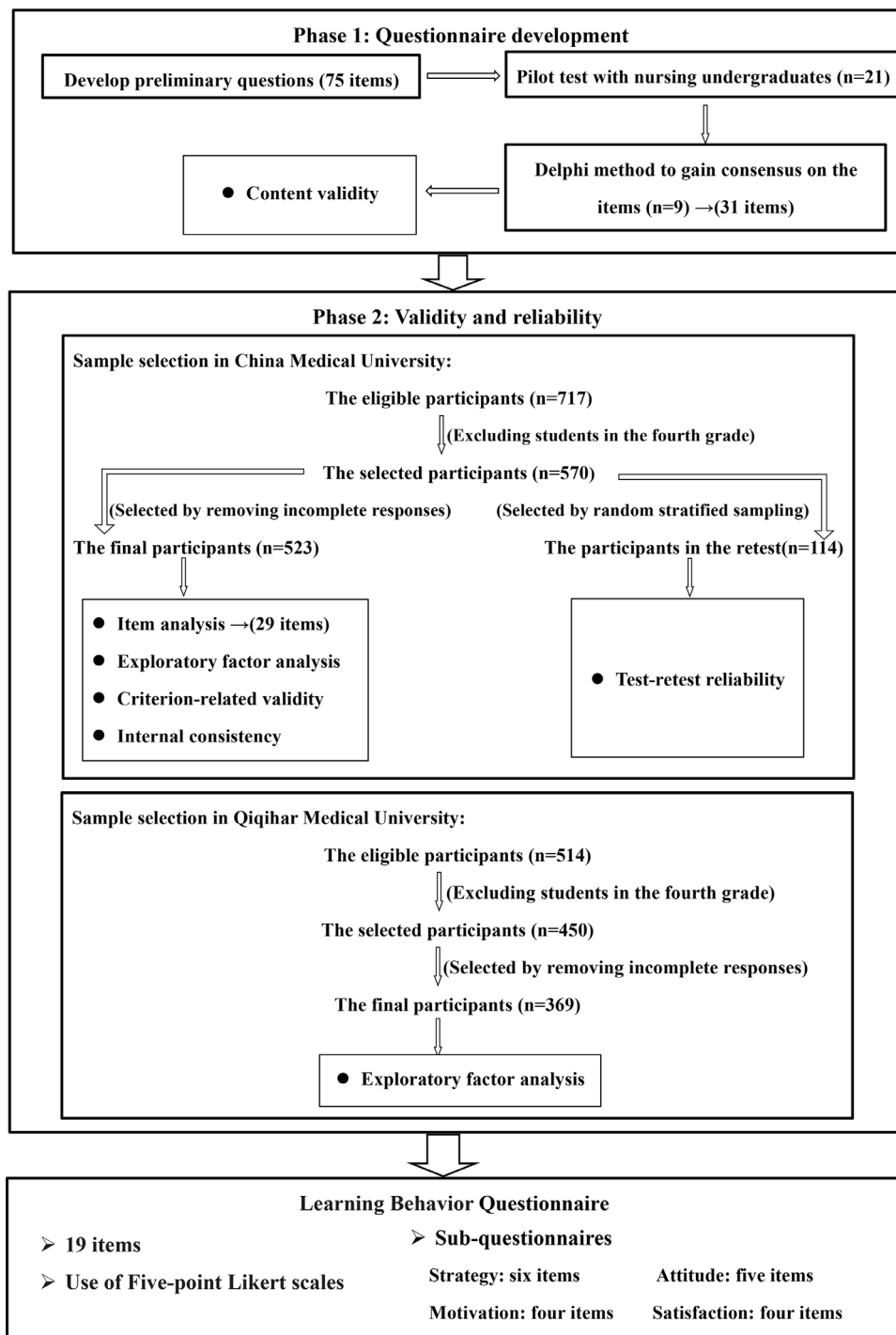
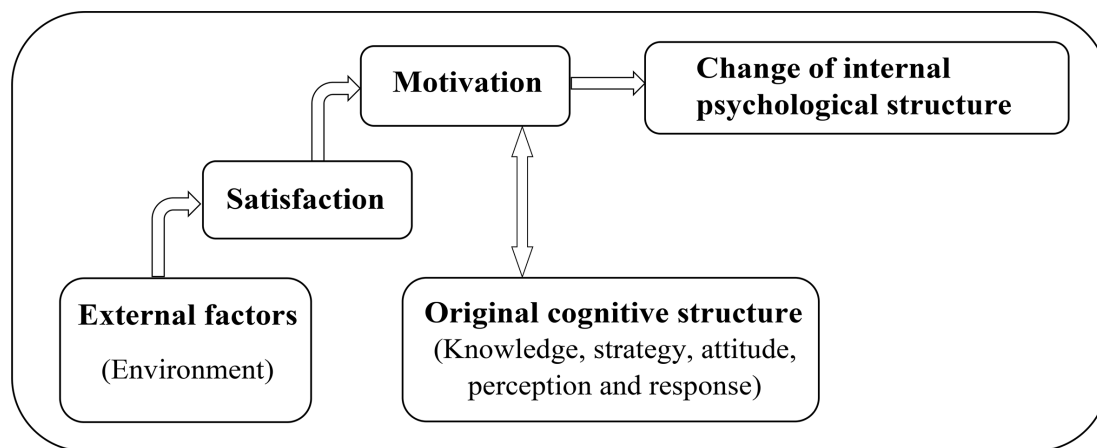

**Figure 1** Questionnaire development and validation process.

self-regulation. This process can help them promote their cognitive pursuit and stimulate their learning motivation.<sup>21</sup> External factors such as the environment provide potential stimuli, which can be transformed into motivation through individual satisfaction levels. Whether the stimuli are noticed or processed depends on the expected guidance of learners. For nursing students, both clinical practice and classroom learning can be seen as a cognitive process; that is, the experience and adjustment of the cognitive structure. The evolving cognitive structure plays a decisive role in learners' behaviour and

current cognitive activities. When the cognitive structure of nursing students evolves in a positive direction, their pursuit and interest of professional-related cognition will be correspondingly improved. They will further develop their learning objectives and plans, to improve their learning initiative and learning behaviour (figure 2).

Meanwhile, we used a semistructured and open-ended qualitative interview format to solicit opinions towards learning behaviour of 12 nursing undergraduates from three different grades by convenience sampling method, with an average of four students in each grade. Among



**Figure 2** Theoretical framework of this study.

them, there were three males and nine females, with an average age of  $(20.47 \pm 1.35)$ . The interview focuses on learning motivation, learning attitude, learning methods and strategies, learning environment and satisfaction, and learning change under self-monitoring learning to explore the real learning process of nursing undergraduates. The interview guide includes the following three aspects (for details see online supplemental file 1): (1) Cognition and views on the process of mastering nursing knowledge; (2) Experience and changes after staged professional learning and (3) Main factors affecting learning initiative. The time of each interview was controlled at 20–30 min.

Based on the cognitive learning theory and the qualitative interviews of 12 nursing undergraduates, a 75-item questionnaire was drafted around six aspects of learning strategy, learning attitude, learning perception, learning initiative, learning motivation and learning satisfaction, with a 5-point rating from '1' (fully disagree) to '5' (fully agree).

In this study, the purpose of the research, the methods used, ethical considerations for the universities and participants, and the official announcement of the research results were explained to the contact person at China Medical University. So as not to identify the participants, this study took the form of an anonymous survey. Participants were fully informed of their freedom to leave the study at any time using a consent form.

### Pilot test with nursing students

Before starting the validation study, a pilot test was conducted. Five percent of nursing students from each grade were selected in the school of nursing (a total of 29 individuals) by simple random sampling technique (lottery method) to examine the clarity and applicability of the items in the LBQ.<sup>22</sup> In addition to the students who were not willing to participate, 21 students were finally involved at this stage. Based on participants' feedback during the pilot test, minor revisions to the wording of the items were made. Participants in the pilot test were excluded from the test of validity and reliability to prevent the impact of repeated answers on the results.

### Delphi method to gain consensus on the items

This study used two rounds of Delphi surveys to get expert consensus and determine the degree of expert agreement about the questionnaire. The paper version of the questionnaire was sent to experts in the same city, while the electronic version was sent to experts in other cities by email. We incorporated nine professors who each had more than 15 years of professional experience. The experts recruited to examine the content validity of the preliminary pilot questions were nursing education experts, nursing education managers and educational psychologists.

At the outset, the authority coefficient ( $C_r$ ) was measured by two factors: the participants' familiarity with the items ( $C_s$ ) and the judgement criteria for the items ( $C_a$ ).<sup>23</sup> Familiarity with items was measured on a five-point rating in the following order and score: unfamiliar (0), somewhat unfamiliar (0.2), somewhat familiar (0.5), very familiar (0.8) and extremely familiar (1). The judgement criteria for the items encompassed parameters such as experience in learning behaviour, theoretical analysis of items, knowledge of the literature, and instinct. A scoring system was used to rate the experts' criterion for their judgements (see online supplemental file 2),<sup>24</sup> and the rating was given by the participants. Informed consent was obtained from each participant once they accepted the invitation to participate.

Subsequently, after a detailed introduction of the purpose, significance, content and the process of constructing the index system framework, the experts evaluated the draft questionnaire for content validity and were asked to rate each item from '1' (not relevant) to '5' (highly relevant) in the first round of Delphi survey. Experts were also asked to make comments, if necessary, about the way that items were asked. According to the agreement on items and the advice of experts, items with a consensus score of  $\geq 4$  by  $>70\%$  of the experts were considered appropriate, and items with a consensus score of  $\leq 2$  by  $>70\%$  of experts participants were excluded. Based on the results of the first round and the revised questionnaire, the second round of Delphi survey re-rated

the importance and feasibility of the items according to the item selection criteria established by the panel discussion and additional edits made. Experts were anonymous to each other during the entire Delphi survey process. After two rounds of consultation and integration of their recommendations, 31 items were retained to phase 2, as Content Validity Index (CVI) must be  $\geq 0.80$ .<sup>25</sup>

## Phase 2: validity and reliability

### Setting and sampling

The sample size was determined by the following determination formula:  $n = Z^2 \times P(1-P) / d^2$ .<sup>26</sup> We set Kolmogorov-Smirnov (Z) at 95% CI, the response distribution (P) at 50%, and error of marginal (d) of 5%.<sup>27</sup> Based on this information, the study population was determined to require at least  $1.96^2 \times 0.5(1-0.5) / 0.05^2 = 384$ . To avoid errors due to the non-response rate, the numbers of students selected for the study were increased by 15%. Therefore, the total number of students selected for the present study was set at 442.

In October 2019, we used the random drawing method to select six classes from each grade, then all the students in each selected class were included in this survey to perform the item analysis and examine a viable factor structure. The criterion-related validity and internal consistency were also assessed based on this. A total of 570 nursing undergraduates in the first-to-third grades of China Medical University were selected. Equally, 450 nursing undergraduates in the first-to-third grades of Qiqihar Medical University were selected in June 2020 to verify whether the factor constructs were appropriate to the sample. Nursing students in the fourth grade have entered the clinical practice stage in the University Teaching Hospitals, so they were not included in this study. The further selection was based on the exclusion criteria: (1) Nursing students who were upgraded from professional college to undergraduate course; (2) Participants of the pilot test and (3) Nursing students who were unwilling to participate in the study.

Two weeks later, a repeated measurement was conducted using the same questionnaire and 114 (around 20% of the students from each grade) participants from three different grades of China Medical University to measure the test-retest reliability. To confirm whether students in the first test were identical to the ones in the second, we asked the participants to identify themselves using the dedicated number, which was not disclosed to other individuals.

### Data collection

The questionnaires of the large sample survey included the following: (1) General demographic questionnaire, which included gender, grade, class and dedicated number; (2) The LBQ, which was developed for this study and constructed to assess the degree of conformity of nursing undergraduates in practice. It included a five-point rating questionnaire with 31 items (1=fully disagree, 2=partly disagree, 3=neither agree nor disagree, 4=partly

agree, 5=fully agree) and (3) Self-Regulated Learning Scale for Undergraduates (SRLS-U),<sup>28</sup> which was mainly proposed by Zeng in 2010 to measure the learning habits and ability of undergraduates. The SRLS-U had 30 items using a five-point rating (1=very inconsistent, 2=not consistent, 3=general consistent, 4=basically consistent, 5=very consistent). It consisted of five subscales: Self-orientation, Learning settings, Learning method, Self-supervision, Self-regulation. The scale has been verified and shown to have high reliability and validity. Cronbach's alpha coefficient of the SRLS-U was 0.894 in this study. All the items of the questionnaire in this survey were described in Mandarin.

The nursing undergraduates filled in the questionnaires anonymously under the guidance of the investigators within 20 min. The questionnaires were collected by the investigators, then were checked and numbered one by one. Only data for students who provided complete responses were analysed. A sample of 523 valid responses of China Medical University was left and reflected a valid response rate of 91.75%, while a sample of 369 valid responses of Qiqihar Medical University was left and reflected a valid response rate of 82.00% in the first test. The response rate for repeated measurement was 100%.

### Similarities and differences between the LBQ and the SRLS-U

Both the SRLS-U and the LBQ took cognitive theory as a part of guiding theory to design evaluation tools for students' learning-related behaviours. On the one hand, the LBQ was different from the SRLS-U in the classification and expression of items. Yet, on the other hand, the LBQ set up some clinical problems for nursing undergraduates and paid more attention to the measurement of the whole process of learning.

### Patient and public involvement

No patient involved.

### Data analysis

Data were analysed using IBM SPSS Statistics V.20.0 (SPSS) and AMOS V.21.0 (SPSS). A Pearson correlation coefficient was used to calculate the correlation of each item with the total questionnaire and the criterion-related validity. The Kaiser-Meyer-Olkin (KMO) measure for sample adequacy and Bartlett's test were conducted to assess whether the data were appropriate for factor analysis. Exploratory factor analysis (EFA) was executed, and subsequent estimation used the maximum likelihood method of extraction and a promax rotation. Only those factors that loaded 0.5 or more were selected as the final items.<sup>29</sup> The CFA was then conducted to verify whether the factor constructs were appropriate to the sample. Several fit indices were calculated, root mean square residual (RMR), comparative fit index (CFI), goodness-of-fit index (GFI), Tucker-Lewis index (TLI), adjusted goodness-of-fit index (AGFI), and root mean square error of approximation (RMSEA). Reliability was analysed with Cronbach's alpha using the internal consistency method.



Excellent internal consistency is present for Cronbach's alpha  $\geq 0.9$ , good for values  $>0.8$  and  $<0.90$ , acceptable for values  $>0.7$  and  $<0.8$ , and questionable for values  $>0.6$  and  $<0.7$ .<sup>30</sup> Test-retest reliability was used to consider stability. If the permissible range of the correlation coefficient in test-retest reliability was higher than 0.7, the test-retest reliability was considered satisfactory.<sup>31</sup>

## RESULTS

### Content validity

Combined with the semistructured interview results of 21 nursing undergraduates, 75 items were initially designed for the LBQ. After the questionnaire was revised according to the feedback of pilot test with 21 nursing students, two rounds of Delphi surveys were conducted. In the first round of Delphi consultation, the  $C_r$  was 0.870, with the values of  $C_s$  and  $C_a$  were 0.873, 0.867, respectively. The level of consensus ranged from 37.44% to 100%, with 19 items falling below 70% for the second round of consultation. Furthermore, since 13 items were raised to be modified, the research group reviewed each and included amendments in the next round as well. The second round included 39 items, most of which had met consensus with a level of agreement between 76.86% and 100%. Since most of these items reached consensus, the final content of the questionnaire was set and the consultation rounds ended. The latest questionnaire contained 31 items. Each item-level CVI was above 0.80, and scale-level CVI was 0.89.

### Item analysis

Cronbach's alpha was used to assess the internal consistency of each item and the LBQ. The Pearson correlation coefficient was used to examine correlations between each item's score and the total score, and items would be removed if the correlation coefficient was small ( $r \leq 0.30$ ) or was insignificant ( $p > 0.05$ ), or if it lowered the Cronbach's alpha of the questionnaire. The procedure was repeated until no item could be removed. According to the item-level analyses, two items (Q26, Q31) were removed. These two items were found to be confusing, and experts also suggested deleting poor/emotional wording ('I often feel anxious and lost in study' and 'I don't think there are many interesting things in the learning process'). The Cronbach's alpha of the LBQ was increased from 0.925 to 0.936. As a result, 29 items were further refined in EFA. For details see online supplemental file 3.

### Construct validity

EFA was conducted on 29 items of the LBQ, which revealed the presence of four factors according to the Kaiser criterion with factor loadings higher than 0.5. The criterion for the four factor cut-off was based on the eigenvalue greater than 1, and the four loadings of each factor were 8.935, 1.953, 1.417, and 1.021, respectively. For details see online supplemental file 4. Six items (Q1, Q2, Q18, Q19, Q25 and Q27) were excluded from further analysis due to

loading less than 0.5. The loading of Q14, 'My ability to decision-making, analysis, and thinking has been greatly improved in school, which makes me very satisfied', on both factors 1 and 4 were higher than 0.5. Still, the difference was less than 0.2, indicating that there were differences in the classification of this item, which ought to be eliminated if it did not meet the statistical requirements. But considering the representativeness of this item to the expected measurement content of the questionnaire and its influence on the structure of the questionnaire, the expert opinion was finally reserved. Considering that Q14 was more inclined to the concept of learning satisfaction in content, it can be further verified by increasing the sample size in the future. The remaining 23 items in the final version of the questionnaire were evaluated using EFA with the maximum likelihood method of extraction and a promax rotation. The KMO measure of sampling adequacy of the LBQ was 0.94, and the Bartlett Test of Sphericity reached statistical significance ( $p < 0.001$ ). These results supported the factor ability of the correlation matrix. The four factors explained a total of 57.85% of the variance.

Given the four factors derived from EFA, an interpretation focusing on higher factor loading items of each factor was performed. Factor 1 was labelled as 'strategy', as it consisted of seven items related to 'specific processes or skills used to solve learning problems'. Factor 2 is composed of six items related to learning objectives and learning psychology, which can reflect learners' attitudes. Therefore, factor 2 was labelled as 'attitude'. Factor 3 was labelled as 'motivation' because it contained five items related to learning interests and learning in life. Finally, the five items in factor 4 included aspects with regard to learning outcomes and capacity enhancement, and this factor was labelled as 'degree of satisfaction'. Item-total correlations were between 0.538 and 0.762, and all the  $p$ -value was less than 0.05. Loadings and factor structure of the items, percentage of variance explained by each factor, and item-total correlations are shown in table 1.

### Construct validity

Confirmatory factor analysis (CFA) was performed to test the validity of the correlated four-factor measurement model based on EFA. Figure 3 presented the final factor structural model of the CFA. At the initial stage, the unidimensional check implied the removal of 4 items (Q3, Q7, Q24 and Q28) to meet the criteria. Finally, all the items demonstrated a good fit within each factor. The final model revealed a good fit to the data ( $\chi^2/df=1.866$ ,  $RMR=0.037$ ,  $CFI=0.950$ ,  $GFI=0.929$ ,  $TLI=0.941$ ,  $AGFI=0.907$  and  $RMSEA=0.049$ ). This analysis provided empirical evidence to consider the LBQ as a second-order construct with four correlated but distinct dimensions.

### Criterion-related validity

We performed a correlation analysis to compare the LBQ with the five subscales from the SRLS-U to confirm the criterion-related validity of the LBQ. Table 2 displays the

**Table 1** Exploratory factor analysis of the Learning Behaviour Questionnaire in undergraduate nursing students

Item	Factor loadings				Item-total
	1	2	3	4	Correlations
<b>Strategy</b>					
3.I can make a comparative analysis of the main points of my knowledge	0.711				0.669
6.Usually, I will make study plans to acquire knowledge according to my study progress and efficiency	0.706				0.677
28.I can adjust my learning method according to the learning effect and clinical events	0.686				0.429
29.I have a comprehensive ability to summarise a wide range of nursing related readings into a systematic knowledge	0.683				0.639
13.I can recognise my strengths and weaknesses in nursing learning	0.653				0.675
17.I can choose my learning methods according to different learning contents	0.649				0.651
11.I think my current learning method is very suitable for my current situation	0.570				0.637
<b>Attitude</b>					
10.I think I should take the initiative to ask the teacher or others for advice when I have problems in nursing study		0.710			0.658
12.I think learning is not only for examination but also for mastering nursing-related knowledge and skills		0.657			0.609
23.I think communicating with other majors is helpful to enrich my learning experience		0.614			0.667
30.I think when I don't understand an important point, I should relearn until understand it		0.601			0.682
24.I know very well that the purpose of my study is to improve my ability		0.577			0.626
4.I think that study is my first task in college		0.569			0.543
<b>Motivation</b>					
21.I want to devote myself to nursing-related work			0.762		0.462
15.I often take various methods to obtain new progress in nursing			0.736		0.590
16.I like to associate nursing knowledge with daily life			0.691		0.597
9.I think the nursing profession will have a good salary and social status in the future, so I study hard			0.615		0.650
5.I like actively participate in every nursing activity			0.559		0.625
<b>Degree of satisfaction</b>					
8.I derive a sense of achievement when I care for patients properly				0.699	0.654
7.It makes me happy to solve some health problems in my life with the knowledge of nursing				0.653	0.641
22.I'm satisfied with my great progress after my nursing study				0.627	0.617
20.I have a sense of achievement in taking care of patients and making them recover				0.569	0.601
14.My ability to decision-making, analysis and thinking has been greatly improved in school, which makes me very satisfied				0.538	0.649
Percentage of variance explained (%)	18.951	15.343	12.282	11.274	
Cumulative percentage of variance explained (%)	18.951	34.294	46.576	57.850	

Backtranslation was conducted by a bilingual speaker of Chinese and English.

calculated correlation coefficients, which confirmed a good criterion-related validity of the LBQ for SRLS-U.

### Reliability

The reliability of the questionnaire was computed by internal consistency (Cronbach's alphas) and test-retest reliability. The total Cronbach's alpha of the questionnaire was 0.936, and the Cronbach's alphas for the four

factors were 0.828, 0.826, 0.804 and 0.805, respectively. The test-retest reliability of the four factors were 0.886, 0.904, 0.852 and 0.875. The total test-retest reliability of the questionnaire was 0.942 ( $p < 0.01$ ).

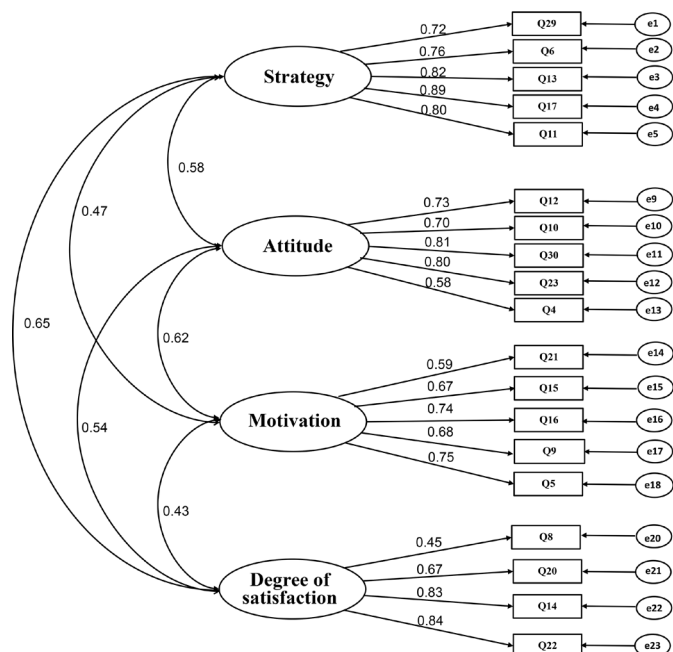

**Figure 3** Confirmatory factor analysis of the Learning Behaviour Questionnaire in undergraduate nursing students.

### DISCUSSION

The nursing quality is central to the medical quality because most healthcare are provided by nurses. With the gradual expansion of nurses' functions from clinical nursing to nursing teaching and research, it is more and more important to train high-end nursing talents. The quality of their learning behaviour in the student stage determines the depth and breadth of their development to a great extent.<sup>32</sup> Meanwhile, learning behaviour is also integral to fostering lifelong learning in the nursing profession. In recent years, the learning-related research focusing on the nursing students is also growing.<sup>33</sup> However, there is a lack of systematic evaluation tools for learning behaviour as a whole. Therefore, it is necessary to develop a comprehensive evaluation tool to evaluate the learning behaviour of nursing students.

In this study, a comprehensive survey provided data to aid in developing and improving the LBQ. The initial questionnaire drew on the advice and opinions of nursing undergraduates and experts in related fields. At the same

time, considering the differences of teaching philosophy and methods between China and Western countries, the LBQ also integrated the influence of group cooperative learning and BPL teaching methods on the learning behaviour of nursing undergraduates at the beginning of design and set up appropriate items. Then gradually revised the topic expression and items, until the final LBQ included 19 items across four factors (see online supplemental file 5 for English version and online supplemental file 6 for Chinese version). The final version of the questionnaire yielded results to show acceptable confirmed content, construct and criterion-related validity, stability and internal consistency reliability.

The final version of the questionnaire consisted of four domains, which were 'strategy', 'attitude', 'motivation' and 'degree of satisfaction'. The four factors matched empirical evidence with cognitive learning theory.<sup>19</sup> In the process of connecting theoretical knowledge with professional practice, nursing undergraduates can use their cognitive function to actively seek learning strategies through their motivation, correct learning attitudes, and self-feedback through learning satisfaction, so as to achieve greater learning and promote cognition and learning behaviour.

'Strategy' (factor 1) is a specific procedure or skill used by learners to solve problems or complete tasks.<sup>34</sup> According to constructivist learning theory,<sup>35</sup> strategy is an active process of processing learning information on the basis of original knowledge, which refers to the rules, methods, skills and adjustments. The theory emphasises the connection between new learning and prior knowledge. On the other hand, students can construct their learning behaviour by evaluating their own advantages and disadvantages.<sup>36</sup> Learning is the product of motivation and strategy, and learning strategy affects learning performance. This factor, which includes generalisation of new knowledge, transformation of original knowledge, and regulation or selection of learning methods, is fundamental.

'Attitude' (factor 2) refers to learners' stable and lasting response to learning, which can adjust students' learning behaviour and affect learning effectiveness.<sup>37</sup> The suggestion of expert consultation was also to emphasise the

**Table 2** Correlation coefficients between the LBQ and the self-regulated learning scale for undergraduates

Factors	SRLS-U				
	Self-orientation	Learning settings	Learning method	Self-supervision	Self-regulation
Strategy	0.723*	0.736*	0.693*	0.692*	0.699*
Attitude	0.733*	0.643*	0.597*	0.672*	0.673*
Motivation	0.741*	0.632*	0.544*	0.674*	0.704*
Degree of satisfaction	0.697*	0.724*	0.676*	0.727*	0.667*
Total LBQ (19 items)	0.837*	0.786*	0.762*	0.757*	0.742*

\*P<0.01.

LBQ, Learning Behaviour Questionnaire; SRLS-U, Self-Regulated Learning Scale for Undergraduates.



importance of hard study to enhance learning behaviour, and that one of the fundamental ways to improve learning behaviour is to cultivate students' serious attitude towards learning. Using appropriate strategies can significantly improve learners' attitude and achieve the purpose of enhancing learning behaviour.<sup>38</sup> For example, 'take the initiative to ask the teacher or others for advice when I have problems' or 'relearn until understand it' can reflect the attitude of learners. Attitude is a powerful precursor of students' learning behaviour input. One of the important points is that it is based on cognition and has certain stability.<sup>39 40</sup> In consequence, to understand the thoughts of nursing undergraduates on learning and the ways to solve the problems, we can evaluate their learning attitude meticulously and comprehensively.

'Motivation' (factor 3) refers to an individual's strong psychological tendency towards learning activities, which is the most endogenous power to influence individual behaviour.<sup>41</sup> It bore a significant impact on learning behaviour.<sup>42 43</sup> A keen motivation in learning is often accompanied by a positive learning attitude and can positively stimulate learning behaviour.<sup>44</sup> Consequently, the study explored the motivation of nursing undergraduates in-depth in the interview. We found that the fierce competition among peers, the sense of achievement in acquiring knowledge, the professional prospect and the sense of social responsibility are the main sources of promoting learning motivation. For example, the item 'I think the nursing profession will have a good salary and social status in the future, so I study hard' provides an opportunity to evaluate the career prospects of nursing, which is highly targeted for nursing students. Moreover, the items on 'Motivation' are more concise than other inventories, like work preference inventory, a widely used evaluation to assess intrinsic and extrinsic motivation.<sup>45</sup> In the LBQ, 'Task involvement' was described as Q5 as an important part of WPI (Work Preference Inventory), while 'Curiosity' was expressed as Q9.

'Degree of satisfaction' (factor 4) refers to individuals' perception of the interaction between their curriculum learning ability and learning effectiveness.<sup>46</sup> Nursing students' learning satisfaction was unique to the individual and changed over time, which may range from short-lived to sustained, and from moderate to vigorous.<sup>47</sup> Learning satisfaction can be significantly improved through social support and acceptance into the learning behaviour construction process.<sup>48</sup> Satisfaction is a two-way indicator, so whether nursing students are recognised in clinical practice and whether they are satisfied with themselves are two essential aspects of this dimension. The item 'I have a sense of achievement in taking care of patients and making them recover' provided a good evaluation for the sense of achievement of nursing patients in clinical nursing practice. In addition, a number of satisfaction scales have been designed. For example, nursing students' satisfaction scale measures the college students' satisfaction with education from the aspects of curriculum and teaching, professional social interaction and learning

environment.<sup>49</sup> However, such scales ignore the sense of gain and satisfaction of nursing students in clinical practice. LBQ makes up for this deficiency.

This study has some limitations. Learning behaviour is not only influenced by individual differences but also has a cultural background. Therefore, this questionnaire may lack cultural adjustments when exploring personal learning behaviour within different cultural backgrounds. In addition, this questionnaire is based on the current situation of the gender ratio of nursing students in China; that is, female students still occupy the majority of the proportion. When the ratio of boys to girls changes, the research results may need to be further explored. Finally, when applied to students with other educational levels, the universal adaptability of this questionnaire needs to be further determined.

## CONCLUSION

Learning behaviour is an essential area of study in the field of pedagogy. This study developed an available tool for measuring nursing undergraduates' attitudes to learning behaviour. In this investigation, the LBQ for undergraduate nursing students was divided into four dimensions: strategy, attitude, motivation and degree of satisfaction. This study provided sufficient evidence for the reliability and validity of LBQ in evaluating the learning behaviour of nursing undergraduates. Therefore, it is suggested that researchers engaged in nursing education should use LBQ or apply it to the teaching evaluation of undergraduate nursing students, so as to further promote the teaching research of undergraduate nursing students.

**Acknowledgements** We would like to thank all the undergraduate nursing students who participated in this study.

**Contributors** YW and SZ designed the study. YW, XH and LQ collected the data. YW analysed the data and drafted the manuscript. YW, SZ, YL and LQ reviewed and edited the manuscript. All authors read and approved the manuscript.

**Funding** This study was funded by The 2016 Liaoning Undergraduate Teaching Reform Project (No. 351) and Research Project of Education Science of Qiqihar Medical University in 2019 (No. QYJY20190140).

**Competing interests** None declared.

**Patient consent for publication** Not required.

**Ethics approval** Ethical approval ((2019) 1) was granted by the Ethics Committee of the School of Nursing at Qiqihar Medical University. Written informed consent of the respondents was obtained.

**Provenance and peer review** Not commissioned; externally peer reviewed.

**Data availability statement** Data are available on reasonable request. Data can be obtained from corresponding authors.

**Supplemental material** This content has been supplied by the author(s). It has not been vetted by BMJ Publishing Group Limited (BMJ) and may not have been peer-reviewed. Any opinions or recommendations discussed are solely those of the author(s) and are not endorsed by BMJ. BMJ disclaims all liability and responsibility arising from any reliance placed on the content. Where the content includes any translated material, BMJ does not warrant the accuracy and reliability of the translations (including but not limited to local regulations, clinical guidelines, terminology, drug names and drug dosages), and is not responsible for any error and/or omissions arising from translation and adaptation or otherwise.

**Open access** This is an open access article distributed in accordance with the Creative Commons Attribution Non Commercial (CC BY-NC 4.0) license, which

permits others to distribute, remix, adapt, build upon this work non-commercially, and license their derivative works on different terms, provided the original work is properly cited, appropriate credit is given, any changes made indicated, and the use is non-commercial. See: <http://creativecommons.org/licenses/by-nc/4.0/>.

## ORCID ID

Shuang Zang <http://orcid.org/0000-0001-7814-8011>

## REFERENCES

- Pan XQ. Analysis on the major stress recourse of nursing staff in obstetrics and gynecology department. *Journal of Traditional Chinese Medicine Management* 2017;25:175–7.
- Park H-Y, Kim J-S. Factors influencing disaster nursing core competencies of emergency nurses. *Appl Nurs Res* 2017;37:1–5.
- TJ W, Tai YN. Effects of multimedia information technology integrated multi-sensory instruction on students' learning motivation and outcome. *EURASIA J Math Sci and Tech Ed* 2016;12:1065–74.
- Goda Y, Yamada M, Kato H, et al. Procrastination and other learning behavioral types in e-learning and their relationship with learning outcomes. *Learn Individ Differ* 2015;37:72–80.
- Schweder S, Raufelder D. Positive emotions, learning behavior and teacher support in self-directed learning during adolescence: do age and gender matter? *J Adolesc* 2019;73:73–84.
- Yao CZ, JR M, Wang HC. A review of the study of "learning behavior" at home and abroad. *Journal of Teaching and Management* 2009;10:48–50.
- Parvan K, Hosseini FA, Bagherian S. The relationship between nursing instructors' clinical teaching behaviors and nursing students' learning in Tabriz University of medical sciences in 2016. *Educ Health (Abingdon)* 2018;31:32–8.
- Shen W-Q, Chen H-L, Hu Y. The validity and reliability of the self-directed learning instrument (SDLI) in mainland Chinese nursing students. *BMC Med Educ* 2014;14:108.
- Liu J-Y, Liu Y-H, Yang J-P. Impact of learning adaptability and time management disposition on study engagement among Chinese baccalaureate nursing students. *J Prof Nurs* 2014;30:502–10.
- Brock D, Abu-Rish E, Chiu C-R, et al. Interprofessional education in team communication: working together to improve patient safety. *BMJ Qual Saf* 2013;22:414–23.
- Li Z, Sun Y, Zhang Y. Adaptation and reliability of the readiness for inter professional learning scale (RIPLS) in the Chinese health care students setting. *BMC Med Educ* 2018;18:309.
- Roces Montero C, Sierra Y Arizmendiarieta B. The effectiveness of a learning strategies program for university students. *Psicothema* 2017;29:527–32.
- Cheng S-F, Lee-Hsieh J, Turton MA, et al. Validation of self-directed learning instrument and establishment of normative data for nursing students in Taiwan: using polytomous item response theory. *J Nurs Res* 2014;22:90–100.
- Kerry MJ, Wang R, Bai J. Assessment of the readiness for interprofessional learning scale (RIPLS): an item response theory analysis. *J Interprof Care* 2018;32:634–7.
- Ülvay GF, Özkul AE. Social-Emotional learning competencies scale of secondary school students. *Eurasia J Math Sci T* 2018;14:1295–304.
- DeCoux VM. Kolb's learning style inventory: a review of its applications in nursing research. *J Nurs Educ* 1990;29:202–7.
- Mountford H, Jones S, Tucker B. Learning styles of entry-level physiotherapy students. *Adv Physiother* 2006;8:128–36.
- İlçin N, Tomruk M, Yeşilyaprak SS, et al. The relationship between learning styles and academic performance in Turkish physiotherapy students. *BMC Med Educ* 2018;18:291.
- Mehrabian A, Russell JA. *An approach to environmental psychology*. Cambridge, MA: The MIT Press, 1974: 62–5.
- Agra G, Formiga NS, Oliveira PSde, et al. Analysis of the concept of meaningful learning in light of the Ausubel's theory. *Rev Bras Enferm* 2019;72:248–55.
- Flavell JH. Metacognition and cognitive monitoring: a new area of cognitive-developmental inquiry. *Am Psychol* 1979;34:906–11.
- Katz LM, Finch A, McKinnish T, et al. Teaching procedural skills to medical students: a pilot procedural skills lab. *Educ Health* 2017;30:79.
- Liu M, He Y, Zhang D, et al. [Reliability and validity of a newly developed tool to be used for the comprehensive geriatric assessment on community elderly]. *Zhonghua Liu Xing Bing Xue Za Zhi* 2016;37:210–3.
- Guo XH. *Medical field investigation techniques and statistical analysis*. Beijing: People's Medical Publishing House Co., LTD, 2009.
- Yalçın B, Baykal Ülkü. Development and psychometric testing of the organizational silence behavior scale for healthcare professionals. *Nurs Health Sci* 2019;21:454–60.
- Cochran WG. *Sampling techniques*. Hoboken, NJ: John Wiley & Sons, 1977.
- Shanti R, Potluri M. *Sample size calculator*. Seattle: Raosoft Inc., 2009.
- Zeng DX. Habitus and field: the influencing factors of college students' autonomous learning ability— an empirical study based on central South university. *Journal of Central South University* 2011;17:128–37.
- Tabachnick BG, Fidell LS. *Using multivariate statistics*. Boston, MA: Pearson/Allyn & Bacon, 2006.
- Tavakol M, Dennick R. Making sense of Cronbach's alpha. *Int J Med Educ* 2011;2:53–5.
- Noguchi N, Inoue S, Shimano C, et al. Development and validation of the humanitarian aid difficulty scale for Japanese healthcare workers. *Nurs Health Sci* 2016;18:442–9.
- Ewertsson M, Gustafsson M, Blomberg K, et al. Use of technical skills and medical devices among new registered nurses: a questionnaire study. *Nurse Educ Today* 2015;35:1169–74.
- Kemppainen V, Tossavainen K, Turunen H. Nurses' roles in health promotion practice: an integrative review. *Health Promot Int* 2013;28:490–501.
- Fryer LK, Vermunt JD. Regulating approaches to learning: testing learning strategy convergences across a year at university. *Br J Educ Psychol* 2018;88:21–41.
- Chun ZY. The roots and logical starting points of constructivist learning theory. *Studies In Foreign Education* 2002;29:27–9.
- Jouhari Z, Haghani F, Changiz T. Assessment of medical students' learning and study strategies in self-regulated learning. *J Adv Med Educ Prof* 2016;4:72–9.
- Xu Y, Wang L, He J, et al. Prevalence and control of diabetes in Chinese adults. *JAMA* 2013;310:948–59.
- Hasanpour-Dehkordi A, Solati K. The efficacy of three learning methods collaborative, context-based learning and traditional, on learning, attitude and behaviour of undergraduate nursing students: integrating theory and practice. *J Clin Diagn Res* 2016;10:VC01–4.
- Suárez N, Regueiro B, Estévez I, et al. Individual precursors of student homework behavioral engagement: the role of intrinsic motivation, perceived homework utility and homework attitude. *Front Psychol* 2019;10:941.
- van Giesen RI, Fischer ARH, van Dijk H, et al. Affect and cognition in attitude formation toward familiar and unfamiliar attitude objects. *PLoS One* 2015;10:e0141790.
- Renninger KA, Hidi SE. *The power of interest for motivation and engagement*. Abingdon, UK: Routledge, 2015.
- Smith CR, Martsof DS, Draucker CB, et al. Stimulating research interest and ambitions in undergraduate nursing students: the research-doctorate pipeline initiative. *J Nurs Educ* 2016;55:133–40.
- Cox JT, Kironji AG, Edwardson J, et al. Global health career interest among medical and nursing students: survey and analysis. *Ann Glob Health* 2017;83:588–95.
- Chong MC, Francis K, Cooper S, et al. Access to, interest in and attitude toward e-learning for continuous education among Malaysian nurses. *Nurse Educ Today* 2016;36:370–4.
- Amabile TM, Hill KG, Hennessey BA, et al. The work preference inventory: assessing intrinsic and extrinsic motivational orientations. *J Pers Soc Psychol* 1994;66:950–67.
- PJ H, Hui W, Clark TH. Technology-assisted learning and learning style: a longitudinal field experiment. *IEEE Transact Sys Man Cybern A: Sys Hum* 2007;37:1099–112.
- Smith MR, Grealish L, Henderson S. Shaping a valued learning journey: student satisfaction with learning in undergraduate nursing programs, a grounded theory study. *Nurse Educ Today* 2018;64:175–9.
- Walker S, Rossi D, Anastasi J, et al. Indicators of undergraduate nursing students' satisfaction with their learning journey: an integrative review. *Nurse Educ Today* 2016;43:40–8.
- Bouffard-Cloutier A, Paré A, McFadden N. Periumbilical vs transumbilical laparoscopic incision: a patients' satisfaction-centered randomised trial. *Int J Surg* 2017;43:86–91.