

# Wireless Patient Monitoring System Based on Smart Wristbands and Central user Interface Software

## Abstract

In this article, a patient monitoring system is proposed that is able to obtain heart rate and oxygen saturation (SpO<sub>2</sub>) levels of patients, identify abnormal conditions, and inform emergency status to the nurses. The proposed monitoring system consists of smart patient wristbands, smart nurse wristbands, central monitoring user interface (UI) software, and a wireless communication network. In the proposed monitoring system, a unique smart wristband is dedicated to each of the patients and nurses. To measure heart rate and SpO<sub>2</sub> level, a pulse oximeter sensor is used in the patient wristbands. The output of this sensor is transferred to the wristband's microcontroller where heart rate and SpO<sub>2</sub> are calculated through advanced signal processing algorithms. Then, the calculated values are transmitted to central UI software through a wireless network. In the UI software, received values are compared with their normal values and a predefined message is sent to the nurses' wristband if an abnormal condition is identified. Whenever this message is received by a nurse's wristband, an acoustic alarm with vibration is generated to inform an emergency status to the nurse. By doing so, health services are delivered to the patients more quickly and as a result, the probability of the patient recovery is increased effectively.

**Keywords:** Heart rate, oxygen saturation level, patient monitoring system, pulse oximeter, Smart wristband, wireless network

Submitted: 31-Jul-2022

Revised: 10-Feb-2023

Accepted: 10-Mar-2023

Published: 14-Feb-2024

## Introduction

Nowadays, hospitals use wristbands to keep track of patient's identity information including name, birth date, and medical record number. Often, these wristbands are made from paper and are disposable.<sup>[1,2]</sup> Nurses and doctors check these wristbands before administering medicine, taking samples, or performing surgery to ensure that each patient receives his/her prescribed treatment correctly.<sup>[3]</sup> However, this identity method has significant drawbacks arises from human errors and wristbands inadequacies, for example, a person received \$12 million in damages from a Maryland Hospital that misidentified him and treated him for cancer instead of head trauma.<sup>[4]</sup> Moreover, the National Practitioner Data Bank recorded about 3700 wrong-treatment/wrong-procedure errors in the USA hospitals over a period of 13 years.<sup>[5]</sup>

This is an open access journal, and articles are distributed under the terms of the Creative Commons Attribution-NonCommercial-ShareAlike 4.0 License, which allows others to remix, tweak, and build upon the work non-commercially, as long as appropriate credit is given and the new creations are licensed under the identical terms.

For reprints contact: WKHLRPMedknow\_reprints@wolterskluwer.com

On the other hand, using disposable wristbands in hospitals imposes a large economic burden on the health-care system, for example, the US Food and Drug Administration (FDA) estimated that adopting electronic medication systems in hospitals can save around \$93 billion in treatment costs over 20 years.<sup>[6]</sup>

According to the explanations, above, using electrical patient identity wristbands in hospitals can yield the following advantages: (i) patient identity information can be programmed into wristbands through the central information section of hospitals; hence, the errors arise from hospital personnel can be avoided effectively; (ii) Since electrical wristbands are not disposable and can be used several times, treatment cost of hospitals reduces effectively after a long period compared to when paper wristbands are used; (iii) smart wristbands can be equipped with various biomedical sensors; by doing so, preferable vital signals can be obtained easily from patients; (iv) smart wristbands

**How to cite this article:** Vafaie MH, Ahmadi Beni E. Wireless patient monitoring system based on smart wristbands and central user interface software. *J Med Sign Sens* 2024;14:3.

**Mohammad Hossein Vafaie,  
Ebrahim Ahmadi Beni**

*Medical Image and Signal Processing Research Center, School of Advanced Technologies in Medicine, Isfahan University of Medical Sciences, Isfahan, Iran*

**Address for correspondence:**  
Dr. Mohammad Hossein Vafaie,  
Medical Image and Signal Processing Research Center, School of Advanced Technologies in Medicine, Isfahan University of Medical Sciences, Isfahan, Iran.  
E-mail: mh.vafaie@amt.mui.ac.ir

Access this article online

Website: [www.jmssjournal.net](http://www.jmssjournal.net)

DOI: 10.4103/jmss.jmss\_47\_22

Quick Response Code:



can be equipped with a wireless data transceiver; by doing so, vital signals obtained from internal equipment of wristband can be transmitted to a preferable receiver and monitored for a long time. Moreover, abnormal conditions can be identified immediately; hence, patients with serious conditions receive treatment as soon as possible. As a result, the probability of patient revival from critical situation increases effectively.

In this article, a wireless patient monitoring system is proposed which is able to monitor the oxygen saturation ( $SpO_2$ ) level and heart-rate value of patients, identify critical conditions, and notify emergency conditions to the nurses immediately. To realize this patient monitoring system, a special type of smart patient wristbands is designed and implemented which is able to calculate  $SpO_2$  level and heart-rate value of a patient through a pulse oximeter sensor and then transmit the calculated values through the wireless transceiver embedded into the wristband. Moreover, a central graphical user interface (GUI) software is proposed that receives the calculated values from the wristband through a wireless receiver.

In the proposed GUI software, the received quantities are plotted. Moreover, the received values are compared with their legal values accordingly. Whenever  $SpO_2$  level or heart-rate value of a person is outside the normal range, relevant nurses are notified immediately through the central GUI software by acoustic alarm and vibration. Furthermore, the patient information as well as his/her bed number is transmitted to the nurses' wristband to guide the nurses to the patient that has a serious condition.

Details about the design and implementation of the proposed patient monitoring system are presented in this article as follows: Hardware of the proposed smart wristband is introduced in section II; the implemented wireless network is presented in section III; the proposed GUI is introduced in section IV; in section V, the developed wristband is compared with some of the recent similar commercial smart-wristwatches; experimental results are presented in section VI, and the conclusion is presented in section VII.

## Proposed Smart Wristbands

To monitor the heart-rate value and  $SpO_2$  level of patients, two types of smart wristbands are proposed in this study: (i) patient wristbands and (ii) nurse wristbands. In the following subsections, both types of the wristbands are introduced in detail.

### Patient wristband

The patient wristbands are designed such that they can do the following tasks: (i) illustrating the patient identity information including name, birth date, national code, medical records summary, etc., on the wristband's

screen; (ii) receiving data from pulse oximeter sensor; (iii) calculating heart-rate value and  $SpO_2$  level of the patient by executing several signal processing algorithms, (iv) transmitting the calculated values to the nurse's wristband and central GUI software through a Zigbee network.

To achieve the objectives, above, the following components are used in the hardware of patient wristbands: (i) a low-power 0.96" Organic light-emitting diode (OLED), (ii) STM32WB55CGU6 microcontroller which is a dual-core high-performance ARM microcontroller equipped with an internal wireless transceiver, (iii) a MAX30100 pulse oximeter sensor, (iv) 1200 mAh lithium-polymer battery, (v) two light-emitting diodes (LEDs) with different colors (red and yellow), (vi) a TTP223 proximity sensor, (vii) an AT24C08 electrically erasable programmable read-only memory (EEPROM), and (viii) a push-button.

The top view of the proposed patient wristband is illustrated in Figure 1. As observed, each patient's wristband consists of two parts: a bracelet closed to the patient's wrist and a pulse oximeter probe fixed on the patient's fingertip.

At reception time, patient identity information as well as patient's medical records are recorded into the central GUI software and then sent to the patient's wristband. When information is received by the wristband, it is shown on the wristband's screen, instantly. The red LED of the

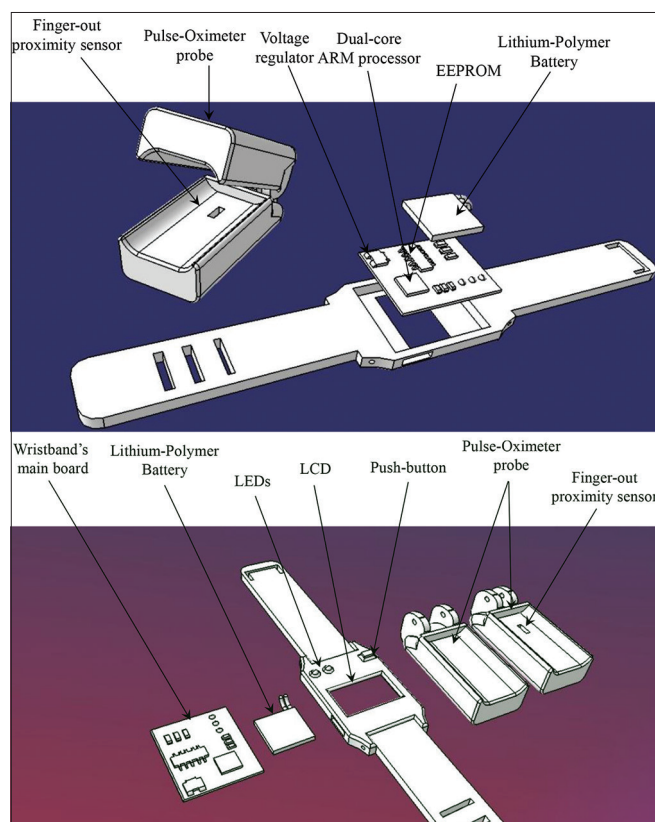

Figure 1: Front view of the proposed wristband

wristband turns on if the patient has previous medical allergies while the yellow LED of the wristband turns on if the patient requires special care (e.g. for seizures and bedsores).

To manage the power consumption of the proposed wristband, TTP223 proximity sensor is placed on the bottom layer of the pulse oximeter probe. The location of the proximity sensor in the wristband is adjusted such that whenever the patient's finger is removed from the front of the pulse oximeter sensor, a trigger pulse is sent to the microcontroller. After receiving this pulse by the microcontroller, pulse oximeter sensor is forced into the standby mode of operation by the microcontroller. In contrast, whenever the patient's finger is placed in front of the pulse oximeter sensor, the pulse oximeter is turned on and SpO<sub>2</sub> level as well as heart rate value of the patient is calculated by the sensor.

MAX30100 sensor combines two LEDs with RED and Infrared Radiation (IR) wavelengths, two photodetectors, optimized optics, and a low-noise analog-to-digital converter (ADC) unit to measure SpO<sub>2</sub> level and heart-rate value.<sup>[7]</sup> The SpO<sub>2</sub> subsystem of the MAX30100 is composed of ambient light cancellation, 16-bit sigma-delta ADC, and proprietary discrete time filter. The MAX30100's ADC is a continuous sigma-delta converter with up to 16-bit resolution. The MAX30100 digital output data is stored in a 16-deep FIFO that can be accessed through an I2C serial port of the microcontroller. The internal block diagram of MAX30100 sensor as well as its schematic is illustrated in Figure 2.

STM32WB55CGU6 which is an ultra-low power dual-core ARM microcontroller is used in the developed wristband as the main processing unit. The first core of the

microcontroller is dedicated to the execution of processing operations while the second core is dedicated to wireless data communication. The wireless core of STM32WB microcontroller supports WiFi, Zigbee, and Bluetooth low energy (BLE) protocol.

The digital output of the pulse oximeter is received by I2C port of the microcontroller and stored in a digital array. In the next step, various signal processing algorithms are applied to the received data to calculate the heart-rate value and SpO<sub>2</sub> level of the patient. Details of the signal processing algorithms adopted in this study to calculate the heart-rate value and SpO<sub>2</sub> level are presented in subsection II.3 of the article.

The calculated values are transmitted to nurses' wristbands and central GUI software through the wireless transceiver core of the microcontroller. Details of the wireless network implemented in this study to transfer data between the wristbands and GUI are presented in section III of this article.

A push button is provided on the body of the patient's wristband; whenever it is pressed by the patient, his/her request as well as his/her name and bed number is transmitted to the relevant nurse's wristband. Therefore, a wireless nurse calling system can be realized through the developed wristbands and the implemented patient monitoring system.

To keep the patient identity information unchanged whenever the wristband supply is lost, an AT24C08 EEPROM is used in patient wristbands. Whenever the wristband's battery voltage becomes lower than the predefined threshold value, patient information is stored in the EEPROM and when the battery voltage is increased again, the information is invoked from the EEPROM.

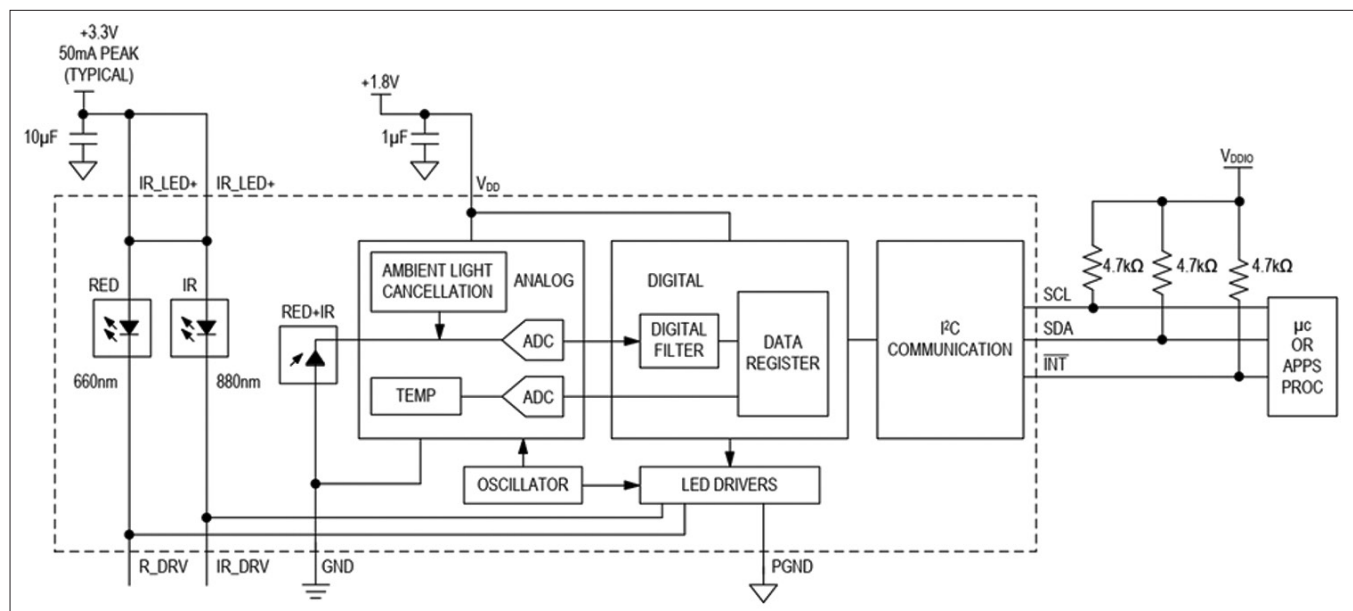

Figure 2: Internal block diagram of MAX30100 sensor as well as the external components used to connect the sensor to the microcontroller<sup>[7]</sup>

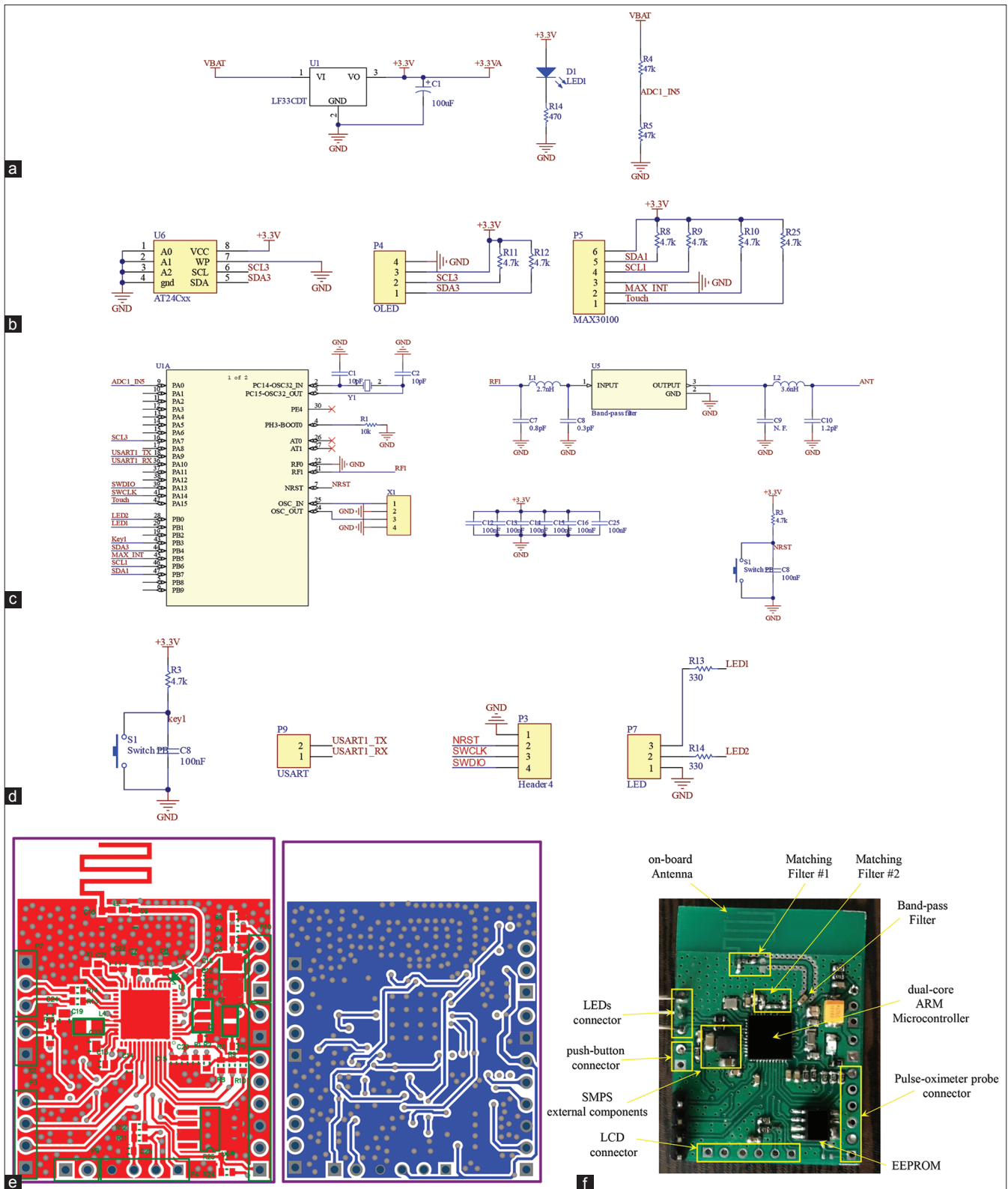

Figure 3: Hardware of the developed wristband: (a) schematic of the voltage regulator, (b) schematics of MAX30100, OLED, and EEPROM, (c) schematic of the microcontroller, (d) schematic of LEDs and a push-button, (e) top and bottom layer of the developed PCB, and (f) implemented wristband's hardware. PCB – Printed circuit board, EEPROM – Electrically erasable programmable read-only memory

Schematics of various parts of the wristband's hardware are presented in Figure 3. In Figure 3a, a schematic of linear voltage regulator adopted to achieve a fixed

3.3V supply is illustrated while in Figure 3b, schematics of MAX30100 sensor, OLED screen, and AT24C08 EEPROM are presented. In Figure 3c, the schematic

of the microcontroller as well as its necessary external components is presented. In Figure 3d, schematics of the two LEDs (red and green), push button, universal-asynchronous-receiver-transmitter (UART) port, and programmer port are illustrated. In Figure 3e, the printed circuit board (PCB) of the developed hardware is presented where the top layer is shown on the left side and bottom-layer is shown in the right side. Finally, in Figure 3f, top view of the developed wristband's hardware is presented.

### Nurse wristband

The nurse wristbands are designed such that they can do the following tasks: (i) monitoring heart-rate value and SpO<sub>2</sub> level of under-supervision patients on the wristband's screen, (ii) notifying emergency situation to nurses by generating acoustic alarms and vibrations.

To achieve the objectives, mentioned above, nurse wristbands are implemented by using the following equipment: (i) a low-power 0.96" OLED, (ii) STM32WB55CGU6 microcontroller which is a dual-core high-performance ARM microcontroller equipped with an internal wireless transceiver, (iii) a 1200 mAh lithium-polymer battery, (iv) a push button, (v) a buzzer, (vi) a vibrator, and (vii) an AT24C08 EEPROM.

The top view of nurse wristbands is just similar to that of the patient wristbands [Figure 1] with only one difference that pulse oximeter probe is eliminated in the nurse wristband.

To minimize the power consumption of the developed nurse wristband, its screen keeps off until the push button placed on the wristband's body is pressed by the nurse. In this situation, the OLED is turned on and patient information including patient name, bed number, heart-rate value, and SpO<sub>2</sub> level are shown on the wristband's screen. By pressing the push button again, information of the next patient is shown on the OLED. Ten seconds after pressing the push button, the wristband's screen is turned off automatically.

Whenever an emergency condition is alerted by central GUI or a call request is received from a patient, an acoustic alarm with vibration is generated by an internal component of the wristband to inform the nurse. Moreover, the type of the alarm (emergency condition or patient request) as well as patient's name and bed number appears on the wristband's screen to guide the nurse to the corresponding patient.

### Signal processing algorithm

Based on MAX30100 datasheet, whenever the internal FIFO of the sensor becomes full a falling edge is appeared on the interrupt pin (INT) of the sensor. The digital words stored in the sensor's FIFO can be read through an I2C serial port of the microcontroller.

Based on the explanations, above, in the developed wristband, the following steps are conducted to calculate SpO<sub>2</sub> level and heart-rate value of a patient:

- i. INT pin of MAX30100 is connected to one of the general-purpose input/output (GPIO) pins of the microcontroller while the GPIO pin is configured as an external INT pin. Serial clock (SCL) and serial data (SDA) pins of the sensor are connected to one of the I2C ports of the microcontroller, I2C1\_SCL and I2C1\_SDA, respectively
- ii. In the service routine function of the GPIO INT, MAX30100's FIFO is read by the I2C serial port of the microcontroller, and the received data is stored in a digital array, for more convenience, at first, the received data are processed in MATLAB software and after finalizing the signal processing algorithms and obtaining desirable simulation results, the finalized signal processing algorithms are coded in C-language and programmed into the microcontroller. In order to process the data by MATLAB, the received data are transmitted to a personal computer (PC) using a UART serial port of the microcontroller and a CP2102 TTL-to-USB converter module
- iii. In the PC, the data are received by serial port of MATLAB software where the following signal processing algorithms are applied to the received data to calculate the SpO<sub>2</sub> level and heart-rate value:
  - The second-order digital notch filter proposed in Hirano<sup>[8]</sup> is adopted to reject undesirable spikes and notches that exist on the received signals. The transfer function of the filter is presented in Eq. 1 where  $\lambda$  is the notch frequency at which there is no transmission through the filter, and  $b$  is the 3-dB rejection bandwidth. Within the frequency band centered at  $\omega = \lambda$  and of width  $b$ , all signal components are attenuated by more than 3-dB. Moreover, the dc gain of the notch filter is 0-dB

$$G(z) = \frac{z^{-2} + 1 - 2a_1z^{-1} + a_2(z^{-2} + 1)}{1 - a_1z^{-1} + a_2z^{-2}} \quad (1)$$

Where,

$$\alpha_1 = \frac{2(1 - \lambda^2)}{1 + \lambda^2 + b} \quad (1a)$$

$$a_2 = \frac{1 + \lambda^2 - b}{1 + \lambda^2 + b} \quad (1b)$$

- A weighted moving average (WMA) filter is used to reject undesirable noises that appeared on the received signals. To keep the computational complexity as low as possible, a second-order WMA filter is used in the developed wristband where its equation is formulated as Eq. 2:

$$x(i) = \frac{1}{8}(x(i-2) + 2x(i-1) + 2x(i) + 2x(i+1) + x(i+2)) \quad (2)$$

Where,  $x(i)$  is  $i^{\text{th}}$  sample of  $x$  signal

In subsection VI.2, the performance of the adopted filters is investigated through various simulations. As will be seen, the performance of the adopted filters is acceptable in the rejection of undesirable spikes and noises

- Golden section search algorithm<sup>[9]</sup> is adopted to find the extremum points of IR and RED signals. Based on the simulation results presented in subsection VI.2, the performance of this algorithm is acceptable in finding the extremum points of the signals
- After finding extremum points, R-parameter is calculated through Eq. 3 where, DC\_IR and DC\_RED represent the area below the minimum level of the IR and RED signals, respectively, while AC\_IR is the area between DC\_IR level and IR signal that is calculated through Simpson's algorithm,<sup>[10]</sup> and AC\_RED is the area between DC\_RED level and RED signal, i.e. calculated through Simpson's algorithm

$$R = \frac{AC\_IR \times DC\_RED}{AC\_RED \times DC\_IR} \quad (3)$$

- After obtaining R-parameter, SpO<sub>2</sub> level can be calculated through Eq. 4 that is obtained by applying a curve fitting algorithm to the R-values and SpO<sub>2</sub>-levels obtained in the calibration stage. Further explanations can be found in subsection VI.3 of the article

$$SpO_2 = 1.4022707R^2 - 33.4392824R + 121.4392775 \quad (4)$$

- The signal processing algorithm, mentioned above, is coded in C-language and programmed into the patient's wristband's microcontroller
- In the microcontroller, apart from executing the signal processing algorithms, the following processes must be conducted simultaneously: receiving data from SpO<sub>2</sub> sensor, illustrating SpO<sub>2</sub> level and heart-rate value on the OLED, and transmitting data to the central GUI. To achieve the desired performance, all the processes, above, must be managed properly by the microcontroller. To do this, the microcontroller is programmed such that the following tasks are executed consequently:
  - Whenever a transition is identified on the INT pin of the MAX30100 module, an INT request is sent to the microcontroller
  - After receiving the GPIO INT request, the service routine function of this INT is executed immediately. In this function, the output of the sensor is read and stored in an array
  - The signal processing algorithm, mentioned in step (iii), is applied to the received data where SpO<sub>2</sub> level and heart-rate value are calculated
  - The calculated values are compared with their normal ranges to identify unusual conditions immediately. Whenever the calculated values are beyond their normal ranges, a predefined message is sent to the central GUI

- The calculated values as well as the status of the patient (normal or abnormal) are sent to the GUI immediately through the internal Zigbee transceiver of the microcontroller
- The patient wristband's screen is updated by the newest calculated values
- The above procedure is repeated continuously whenever a new transition is occurred on the INT pin of the MAX30100 sensor.

## Proposed Wireless Network

In the developed patient monitoring system, data are communicated between wristbands and central GUI through a Zigbee network. As mentioned earlier, each wristband is equipped with a low-power dual-core STM32WB microcontroller. By the proper configuration of the second core of the microcontroller, each wristband can send/receive data in a wireless manner.<sup>[11]</sup>

### Wireless transceiver hardware

The radio frequency (RF) part of the developed wristband is designed based on the following principle: in order to achieve the maximum accessible coverage range for the wireless network, the maximum power must be transferred from the RF pin of the microcontroller to the antenna.<sup>[12]</sup>

To satisfy the constraint, above, impedance matching is essential for all parts of the RF data transmission hardware which includes: microcontroller RF pin, band-pass filter, and antenna. It must be noted that a proper band-pass filter must be used in the RF part of the hardware to reject undesirable harmonics in the RF line and ensure that the harmonics in the transmitted data are compliant with the Federal Communications Commission (FCC) regulation.<sup>[13]</sup>

Often, to achieve the impedance matching between two parts of a circuit, a positive matching filter is placed between these two parts. Consequently, the following two matching filters are placed in the hardware of the developed wristband: (i) a  $\pi$ -type LC filter between RF pin of the microcontroller and input of the band-pass filter, (ii) a  $\pi$ -type LC filter between output of the band-pass filter and on-board antenna.

The first matching filter is placed as close as possible to the microcontroller pin while the second one is placed as close as possible to the antenna. The schematic of the matching filters is illustrated in Figure 3c while the part number of the matching filter components is tabulated in Table 1.

The value of the matching filters components depends on the impedance of the microcontroller's RF pin, impedance of the band-pass filter input, and impedance of the antenna. Therefore, in the developed hardware, RF line between microcontroller and antenna is designed based on a single coplanar structure<sup>[14,15]</sup> in which the width of RF line on the PCB is optimized to achieve the best impedance matching.

**Table 1: Radio frequency matching filters components**

Part number	Specification
Between RF pin and band-pass filter input	
GRM1555C1HR80BA01D	0.80pF±0.1pF, multilayer ceramic capacitor
LQG15HS2N7S02	2.7nH±0.3nH, multilayer RF inductor
GRM1555C1HR30WA01D	0.30pF±0.05pF, multilayer ceramic capacitor
Between band-pass filter output and the antenna	
GRM1555C1HR80BA01D	0.80pF±0.1pF, multilayer ceramic capacitor
LQG15HS3N6S02	3.6nH±0.3nH, multilayer RF inductor
GRM1555C1HR2WA01D	1.20pF±0.05pF, multilayer ceramic capacitor
RF – Radio Frequency	

In this optimization problem, the width of the RF line is optimized according to the thickness of the PCB core, material of the dielectric used in the PCB, the thickness of the dielectric, thickness of the copper on the PCB layer containing RF line, thickness of the silkscreen, clearance between RF line and ground plane, and frequency of the RF line.<sup>[16,17]</sup>

To compliant with FCC regulation, the frequency of wireless data communication is adjusted to 2.45 GHz and a band-pass filter with center frequency of 2.45 GHz is placed in the RF line. Moreover, two ground planes are placed on the top and bottom layers of the developed PCB while numerous vias are placed adjacent to the RF line for shielding purposes.<sup>[18]</sup>

After preparing the wristband hardware, firmware of the Zigbee network is programmed into the wireless core of the microcontroller while processing algorithms as well as interfacing operations, which are coded in C-language, are programmed into the processing core of the microcontroller. Whenever a wristband is powered on, its Zigbee network is initialized, at first, and after stabilization of the network, the other operations begin.

### Wireless protocol

Through the second core of the STM32WB microcontroller, data can be sent or received in wireless protocols of WiFi, Zigbee, or BLE.

In this study, WiFi, Zigbee, and NRF protocols are investigated to implement the wireless network where Zigbee protocol is selected as the best choice since it has the lowest power consumption and highest security level among the other protocols.<sup>[19]</sup>

In each Zigbee network, a device is configured as server (or coordinator). The secure pan-id of the network is set initially by the coordinator. Moreover, the number of

endpoints that can be connected to the network as well as the unique short address of each endpoint is specified in the network configuration stage. Consequently, illegal access to the network is not possible. On the other hand, since Zigbee networks cannot be discovered by WiFi devices, the security level of the Zigbee networks is considerably higher than that of the WiFi networks.

Based on the experimental results, the indoor coverage distance of the developed Zigbee network is about 25 m which can be expanded to 260 m by adopting augmenting modules and external antennas.

In the developed patient monitoring system, since GUI behaves as the central monitoring device of the network and receives all patients' data, it is better to configure the GUI software as the coordinator and the wristbands (both the patient and nurse wristbands) are configured as the endpoints (or clients). This configuration has the following advantages in comparison with the other server-client configurations:

- i. The lowest data traffic
- ii. All settings of the wristbands can be performed graphically through the GUI
- iii. The relationship between the patients' wristbands and the nurses' wristbands can be introduced easily in the GUI. Therefore, each patient's data are only transferred to his/her dedicated nurse
- iv. Occurrences of unusual conditions can be identified immediately and then informed to any desirable group of nurses; hence, primary care can be applied to the patient with critical condition through the nearest nurses.

Apart from the benefits, above, since all parts of the Zigbee network are implemented in this study, there is no limitation in the configuration of the developed Zigbee network. That is, instead of GUI software, one of the nurses' wristbands can be selected as the server of the Zigbee network.

### Proposed Graphical User Interface Software

The proposed GUI software is designed such that it can do the following tasks: (i) initializing patient wristbands at patients' reception time and storing their identity information into the wristbands, (ii) managing the implemented Zigbee network as well as data communication between wristbands and the GUI, (iii) receiving heart-rate value and SpO<sub>2</sub> level of all the patients and illustrating them on the GUI screen, (iv) identifying emergency condition by comparing the received values with their normal ranges, and (v) notifying nurses about the emergency conditions by sending a predefined message to the nurses' wristbands immediately.

The proposed GUI software is coded in C# language using Visual Studio 10 Enterprise software where the generated executable file of the software can be run on the Windows operating system.

In Figure 4, various pages of the proposed GUI software are presented. As observed, filtered signal of the pulse oximeter

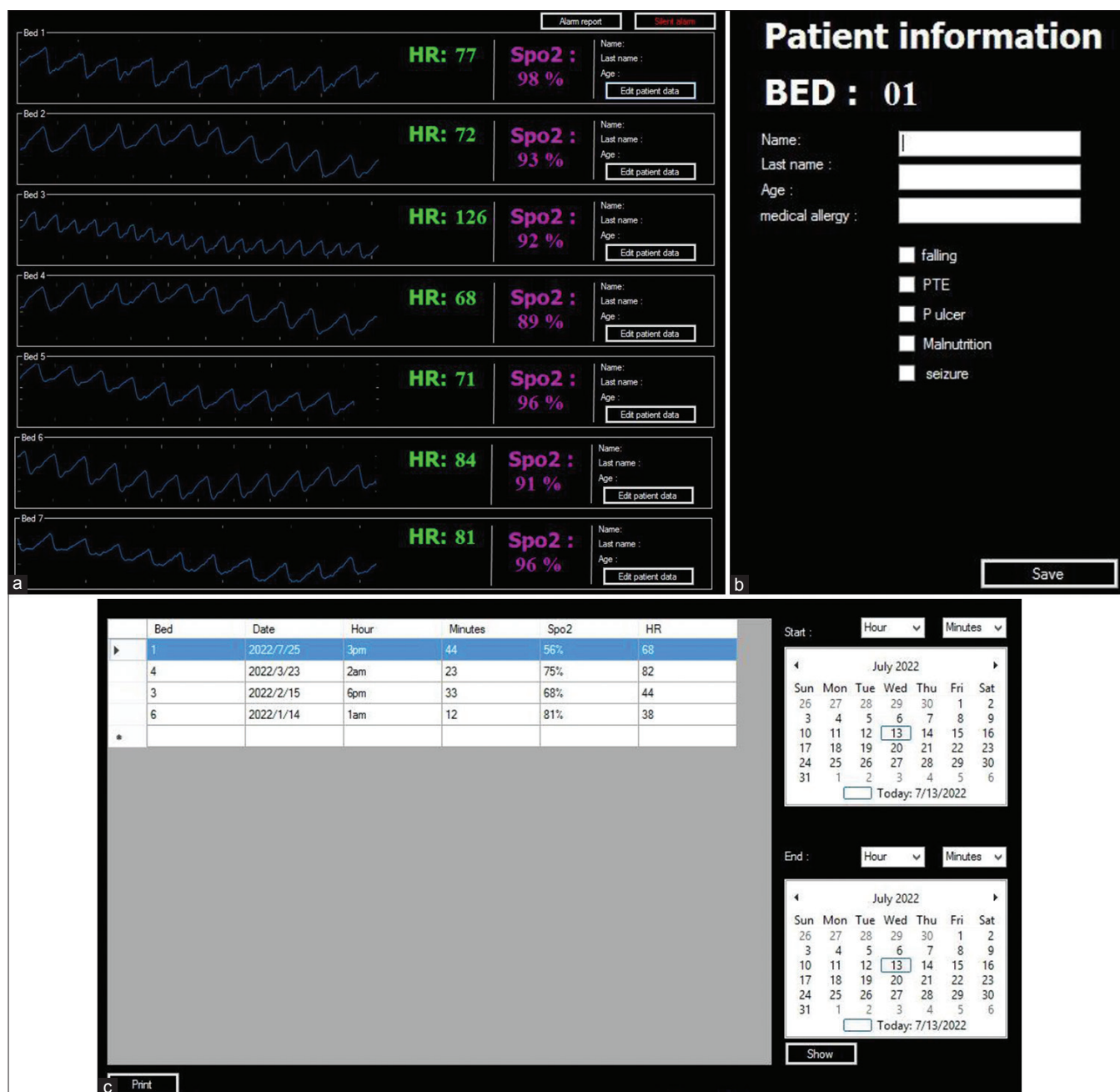

Figure 4: Proposed central GUI software: (a) main page, (b) page dedicated to patient identity information editing, and (c) page dedicated to history of the emergency conditions. GUI – Graphical user interface

output, heart-rate value, and SpO<sub>2</sub> level of all the patients are presented simultaneously on the main page of the software. In this page, by clicking on “Edit patient data.”

Icon, another page [Figure 4b] is opened which is dedicated to record, editing and save the patient identity information. On the main page, by clicking on “Alarm history” icon, another page [Figure 4c] is opened which is dedicated to time and date of all emergency conditions identified by the software on an adjustable time period. On this page, by clicking on each row, identity information of the patient whom has the emergency condition is presented.

In the initialization stage of the developed Zigbee network, all configurations of the wristbands (for both the patient’s and nurse’s wristbands) are made in the GUI software. Moreover, based on the clinic or hospital policies, each patient is dedicated to a specified nurse (or specified nurses). The relationship between the patient and its dedicated nurse(s) is introduced as a communication rule in the GUI software. Whenever a patient’s data are received by the GUI, according to the predefined communication rules, the software identifies the relevant nurse(s) of the patient and sends the patient’s data only to the relevant nurse(s). By doing so, privacy and security



of the patients are satisfied while the data traffic is minimized.

### Comparison with Recent Similar Wristbands

A wristwatch-based wireless sensor platform for wearable health monitoring applications is presented in.<sup>[20]</sup> In this wristwatch, SpO<sub>2</sub> level and heart-rate value of a person are obtained by analyzing the photoplethysmography signal. In this study, at first, a comparison between the wireless performance in the 868 MHz and 2.45 GHz bands is performed and then a compact wireless sub-system for 868 MHz is designed and implemented. Moreover, a highly integrated 868 MHz antenna is designed where the antenna structure is printed on the surface of a wristwatch enclosure using laser-direct structuring technology.<sup>[20]</sup>

The differences between the wristwatch developed in<sup>[20]</sup> and the wristband developed in our study can be summarized as follows:

1. The wireless network of the wristwatch proposed in Kumar<sup>[20]</sup> operates in 868 MHz band while the wireless network of our developed wristband operates in 2.45 GHz band. The 2.45 GHz band wireless network has the following advantages compared to the 868 MHz band:
  - a. Worldwide availability since the majority of wearable devices operate in 2.45 GHz frequency band; in contrast, 868 MHz band only supported in Europa
  - b. A higher data rate
  - c. Compatibility with a larger number of wireless standards
  - d. Smaller size antenna.
2. In the wristwatch proposed in Kumar<sup>[20]</sup> only point-to-point communication is available for data communication between the wristwatch and a wireless gateway device; that is, several wristwatches of this type cannot be joined together to form a wireless network. However, in our developed wristband, both versions of patient and nurse wristbands can be joined together to form a wireless network. This feature made the proposed wristband an ideal wearable device for the central monitoring section of intensive care units where the vital signals of several patients must be monitored and controlled simultaneously
3. In our proposed wristband, initial configurations of the wristbands can be performed easily through the developed central GUI software. By doing so, the patient's identity information as well as the patient's medical records are transferred from the GUI to the wristband. The identity information is illustrated on the wristband screen while medical records are represented by two LEDs: a red LED to inform the nurse that the patient has previous medical allergies and a yellow LED to inform the nurse that the patient requires special care (e.g. for seizures and bedsore). However, none of these features are provided in the wristwatch proposed in Kumar<sup>[20]</sup>
4. In the hardware of the wristwatch proposed in Kumar<sup>[20]</sup> two processors are used where the first one executes signal processing algorithms and the second one manages the wireless data communications. Moreover, an NRF52 BLE module is connected to the SAM R30 platform to implement Bluetooth communication between the gateway device and a smartphone. However, in our developed wristband, only an ultra-low power dual-core STM32 microcontroller is used to perform the entire signal processing algorithms as well as wireless data communications. The first core of this microcontroller executes the signal processing algorithms, while the second core implements Zigbee and BLE protocols simultaneously. Consequently, power consumption of our developed wristband as well as its size, weight, and cost is significantly lower than that of the wristband proposed in Kumar.<sup>[20]</sup>

In addition to the wristwatches reported in the literatures, our developed wristband is compared with the commercial wristwatches.<sup>[21-23]</sup> The comparisons indicate that all of these wristwatches suffer from the lack of networking capability and initialization capability through a GUI software. Furthermore, the hardware and software of commercial wristwatches cannot be modified or enhanced by the user. In contrast, since both the hardware and software of our developed wristband are designed and implemented in this study, any desirable modification, optimization, and enhancement can be made on the wristband in future. Therefore, by enhancing the performance of the wristband and incorporating various medical sensors, other health parameters such as blood pressure, body temperature, and respiration rate can be measured by our developed wristband.

### Experimental Results

To assess the performance of the developed wristbands as well as the proposed monitoring system, a prototype is

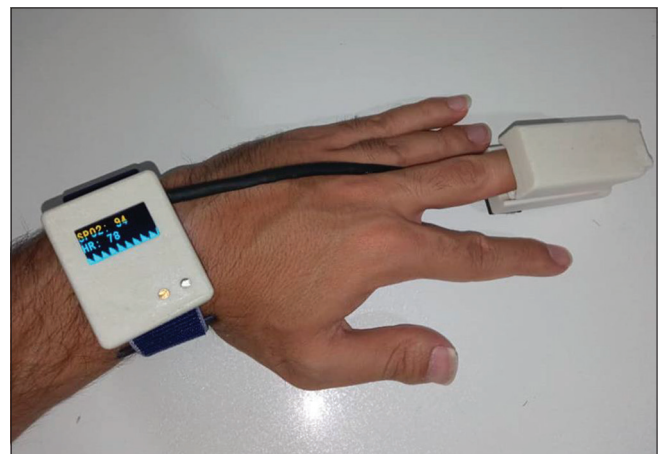
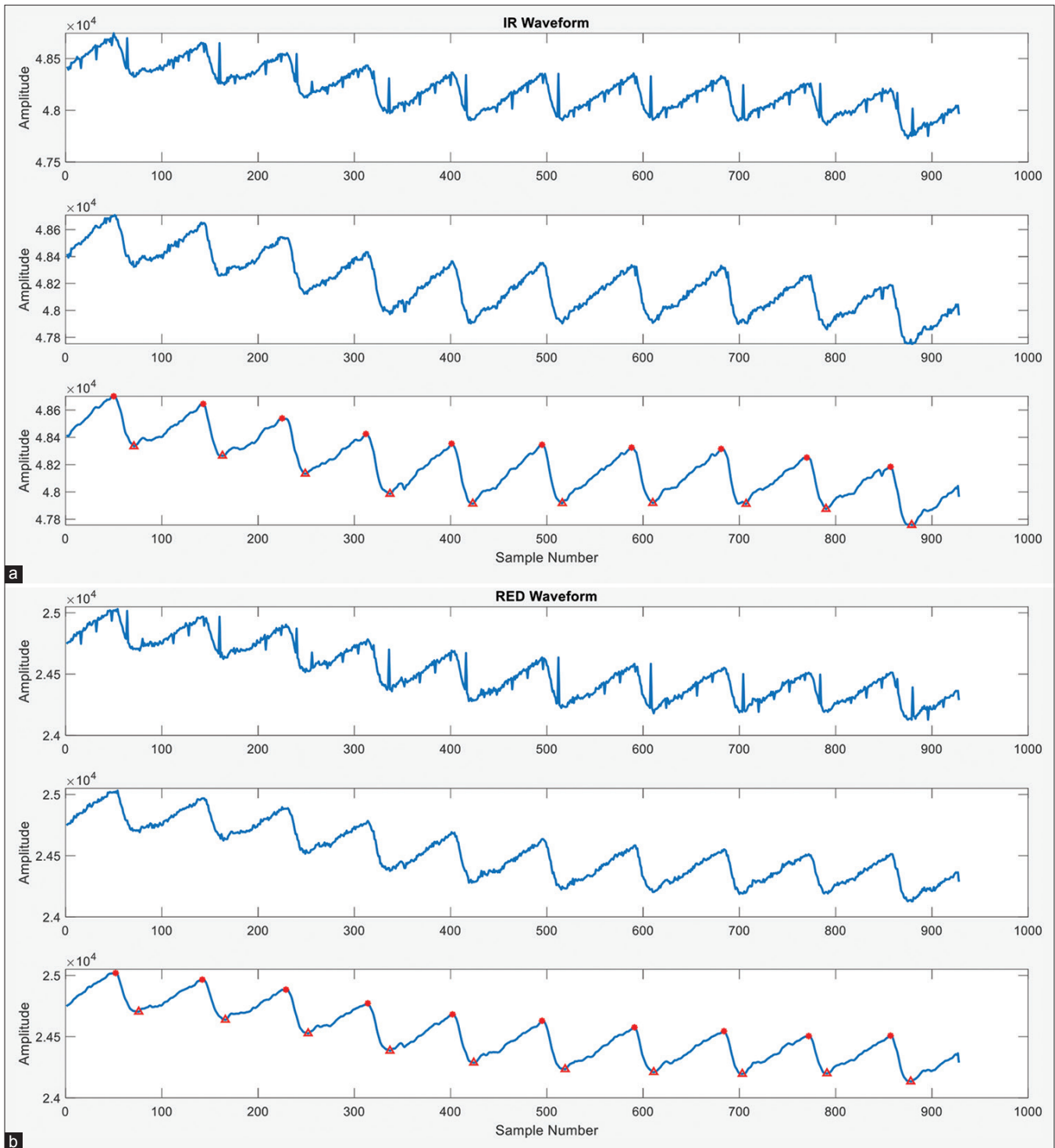

Figure 5: Picture of the implemented patient wristband: (a) wristband and (b) pulse oximeter sensor probe



**Figure 6: Performance of the proposed algorithm in filtering the output waveforms of a pulse oximeter sensor: (a) IR waveform, and (b) RED waveform. IR – Infrared Radiation, RED**

designed and implemented where the results are provided in the following subsections.

### Patient wristband

An image from the first version of the implemented wristband is illustrated in Figure 5. As observed, the bracelet is closed to the patient's wrist while the pulse

oximeter probe is fixed to the patient's fingertip. The heart-rate value and  $SpO_2$  level of the patient are calculated and illustrated on the wristband's Liquid Crystal Display (LCD) while a filtered version of IR waveform of the pulse oximeter sensor is plotted in a real-time manner in the bottom of the wristband's screen.

**Table 2: Heart-rate value and oxygen saturation level of 20 random patients**

Values calculated by the proposed wristband		Values obtained from Beurer P0-30 pulse oximeter	
Heart-rate (bpm)	SpO <sub>2</sub> (%)	Heart-rate (bpm)	SpO <sub>2</sub> (%)
76	96	76	97
55	87	57	85
83	94	82	93
86	95	86	95
77	97	77	97
80	97	81	97
80	96	80	95
67	93	66	94
76	95	76	96
60	95	60	96
78	96	76	96
76	93	76	93
64	92	66	94
75	98	77	97
77	97	76	97
82	98	80	98
78	97	79	97
65	89	65	88
87	94	87	95
75	98	73	97

SpO<sub>2</sub> – Oxygen saturation

### Signal processing algorithm

In this subsection performance of the signal processing algorithm proposed in subsection II.3 is assessed through simulations where the results are presented in Figure 6. As observed, at first, the proposed notch filter is applied to the raw data received from the pulse oximeter sensor (top waveforms in Figure 6a and b to eliminate undesirable spikes and notches. The output of the notch filter is presented in Figure 6a and b (middle waveforms). At second, the proposed WMA filter is applied to the output of the notch filter to eliminate undesirable noises and disturbances. The output of the WMA filter is presented in Figure 6a and b (bottom waveforms). At third, the golden section algorithm is applied to the filtered signal to find the extremum points. At fourth, heart rate value is calculated by counting the number of extremum points found in one second of the signals. Finally, SpO<sub>2</sub> level is calculated through Eq. 4.

### Pulse oximeter calibration

The noninvasive calibration method proposed in Norbert and Niwayama<sup>[24]</sup> is adopted in this study to calibrate the developed pulse oximeter sensor. This method is carried out without any blood sampling.

Pulse oximeters measure the R-parameter, which is proportional to the SpO<sub>2</sub> level. Calibrating a pulse oximeter means finding a mathematical function between the R-parameter and SpO<sub>2</sub> level. In this study, Beurer

P0-30 device,<sup>[25]</sup> which is a medical-grade calibrated pulse oximeter, is used as the reference device for calibrating the developed pulse oximeter.

In the calibration process, 15 min long measurements were performed for four persons with different skin colors while both the reference pulse oximeter (Beurer P0-30) and the developed pulse oximeter are attached to the subject's fingertips at the same time. In the calibration process, air with variable oxygen content was inhaled by each subject while the following two parameters are measured continuously: (i) SpO<sub>2</sub> level which is measured by the reference pulse oximeter, and (ii) value of R-parameter which is measured by the developed pulse oximeter.

Based on the measured data pairs, a mathematical function is determined between the R-values and SpO<sub>2</sub> levels. To do this, the obtained data pairs are imported to MATLAB software where the mathematical function is estimated by curve fitting. By doing so, the mathematical function presented in<sup>[4]</sup> is obtained.

Although increasing the order of the estimated function can improve the accuracy of the SpO<sub>2</sub> calculation, to minimize the computational complexity, a second-order function presented in (4) is adopted in the developed pulse oximeter. The experimental results obtained in calibration stage show that the average error of the developed pulse oximeter is 1.57% with respect to the Beurer P0-30 device which is appropriate in medical practice.<sup>[25]</sup>

### Developed pulse oximeter performance

To assess the accuracy of the developed pulse oximeter, apart from the examinations conducted in the calibration stage, one hundred hospitalized persons are selected randomly where heart-rate value and SpO<sub>2</sub> level of them are measured through the following two devices: (a) the wristband developed in this study, and (b) Beurer P0-30 pulse oximeter.

A small portion of the results obtained from this examination is presented in Table 2 where the values calculated by the developed pulse oximeter have an average error of 1.34% which is in agreement with the values obtained from Beurer P0-30 pulse oximeter.

### Conclusion

In this article, a patient monitoring system consists of patient wristbands, nurse wristbands, and central GUI software is proposed to (i) record patient identity information at reception time and transfer it to the patient wristband, (ii) monitor heart-rate value and SpO<sub>2</sub> level of all the patients continuously, (iii) identify critical conditions, and (iv) inform emergency status to the nurses immediately.

Based on the explanations provided in this article, it can be deduced that the proposed monitoring system has the

following advantages compared to the previous projects conducted in this context:

- i. Central GUI software with the ability to: (i-1) manage the wristbands as well as the wireless network, (i-2) edit and save the patients identity information at patient reception time, (i-3) receive heart-rate value and SpO<sub>2</sub> level continuously and show them on the GUI screen, (i-4) identify critical conditions and notify nurses immediately
- ii. Nurses wristbands with the ability to: (ii-1) receive emergency alerts from the GUI and notify nurses by generating acoustic alarm and vibrations, (ii-2) observe heart-rate value and SpO<sub>2</sub> level of the patients on the wristband's LCD
- iii. Calculating heart-rate value and SpO<sub>2</sub> level simultaneously by adopting advanced signal processing algorithms
- iv. Communicating data between the patient wristbands, nurse wristbands, and central GUI by means of a secure low-power wireless network.

In brief, using the proposed monitoring system, emergency conditions can be identified immediately. As a result, treatment and recovery operations can be begun as soon as possible. By doing so, successful rate of patient's treatment and recovery is increased effectively.

### Financial support and sponsorship

None.

### Conflicts of interest

There are no conflicts of interest.

### References

1. Paparella SF. Accurate patient identification in the emergency department: Meeting the safety challenges. *J Emerg Nurs* 2012;38:364-7.
2. Smith AF, Casey K, Wilson J, Fischbacher-Smith D. Wristbands as aids to reduce misidentification: An ethnographically guided task analysis. *Int J Qual Health Care* 2011;23:590-9.
3. Howanitz PJ. Errors in laboratory medicine: Practical lessons to improve patient safety. *Arch Pathol Lab Med* 2005;129:1252-61.
4. Sevdalis N, Norris B, Ranger C, Bothwell S, Wristband Project Team. Closing the safety loop: Evaluation of the national patient safety Agency's guidance regarding wristband identification of hospital inpatients. *J Eval Clin Pract* 2009;15:311-5.
5. Renner SW, Howanitz PJ, Bachner P. Wristband identification error reporting in 712 hospitals. A College of American Pathologists' Q-Probes study of quality issues in transfusion practice. *Arch Pathol Lab Med* 1993;117:573-7.
6. Nakhleh RE, Souers RJ, Bashleben CP, Talbert ML, Karcher DS, Meier FA, *et al.* Fifteen years' experience of a College of American Pathologists program for continuous monitoring and improvement. *Arch Pathol Lab Med* 2014;138:1150-5.
7. Available from: <https://www.analog.com/en/products/max30100.html#product-overview>. [Last accessed on 2023 Mar 01].
8. Hirano K, Nishimura S, Mitra S. Design of Digital Notch Filters. Vol. 22. *IEEE Transactions on Communications*. 1974. p. 964-70.
9. Tsai CH, Kolibal J, Li M. The golden section search algorithm for finding a good shape parameter for meshless collocation methods. *Eng Anal Boundary Elem* 2010;34:738-46.
10. Ramos H, Singh G. A note on variable step-size formulation of a Simpson's-type second derivative block method for solving stiff systems. *Appl Math Lett* 2017;64:101-7.
11. Timpel P, Oswald S, Schwarz PE, Harst L. Mapping the evidence on the effectiveness of telemedicine interventions in diabetes, dyslipidemia, and hypertension: An umbrella review of systematic reviews and meta-analyses. *J Med Internet Res* 2020;22:e16791.
12. Rathod VT. A review of electric impedance matching techniques for piezoelectric sensors, actuators and transducers. *Electronics* 2019;8:169.
13. Zaikou Y, Nacke T, Pliquet U. High Frequency Impedance Spectroscopy for Biotechnological Applications. 2021 International Workshop on Impedance Spectroscopy (IWIS); 2021. p. 70-5.
14. Zhao X, Tong Y, Tang Q, Liu Y. Wafer-scale coplanar electrodes for 3D conformal organic single-crystal circuits. In: *Advanced Electronic Materials*. New York, United States: John Wiley & Sons; 2015.
15. Zhao N, Liu J, Li H, Li T, Chen W. Single and double superconducting coplanar waveguide resonators. *Chin Phys Lett* 2012;29:088401.
16. Zhang N, Jiang WX, Ma HF, Tang WX, Cui TJ. Compact high-performance lens antenna based on impedance-matching gradient-index Metamaterials. *IEEE Trans Antennas Propag* 2019;67:1323-8.
17. Li Y, Dong W, Yang Q, Zhao J, Liu L, Feng S. An automatic impedance matching method based on the feedforward-backpropagation neural network for a WPT system. *IEEE Trans Ind Electron* 2019;66:3963-72.
18. Zhou Z, Li Y, Nahvi E, Li H, He Y, Liberal I, Engheta N. General impedance matching via doped epsilon-near-zero media. *Phys Rev Appl* 2020;13:034005.
19. Ding S, Liu J, Yue M. The use of ZigBee wireless communication technology in industrial automation control. *Wirel Commun Mob Comput* 2021;2021:1-11.
20. Kumar S, Buckley JL, Barton J, Pigeon M, Newberry R, Rodencal M, *et al.* A Wristwatch-based wireless sensor platform for IoT health monitoring applications. *Sensors (Basel)* 2020;20:1675.
21. Available from: <https://www.samsung.com/us/watches/galaxy-watch4-classic/>. [Last accessed on 2023 Mar 01].
22. Available from: <https://www.mi.com/global/product/mi-watch/>. [Last accessed on 2023 Mar 01].
23. Available from: <https://www.mi.com/in/redmi-watch/>. [Last accessed on 2023 Mar 01].
24. Norbert S, Niwayama M. Non-invasive calibration method for pulse oximeters. *Period Polytech Elec Eng* 2008;52:91-4.
25. Available from: <https://www.beurer.com/web/gb/products/medical/ecg-and-pulse-oximeter/pulse-oximeter/po-30.php>. [Last accessed on 2023 Mar 01].