

ORIGINAL ARTICLE

# A new technique based on Artificial Bee Colony Algorithm for optimal sizing of stand-alone photovoltaic system



Ahmed F. Mohamed \*, Mahdi M. Elarini, Ahmed M. Othman

Electrical Power and Machine Department, Faculty of Engineering, Zagazig University, Egypt

ARTICLE INFO

Article history:

Received 19 March 2013

Received in revised form 13 June 2013

Accepted 28 June 2013

Available online 6 July 2013

Keywords:

PV array

Storage battery

Inverter

Bee colony

Genetic algorithm and life cycle cost

ABSTRACT

One of the most recent optimization techniques applied to the optimal design of photovoltaic system to supply an isolated load demand is the Artificial Bee Colony Algorithm (ABC). The proposed methodology is applied to optimize the cost of the PV system including photovoltaic, a battery bank, a battery charger controller, and inverter. Two objective functions are proposed: the first one is the PV module output power which is to be maximized and the second one is the life cycle cost (LCC) which is to be minimized. The analysis is performed based on measured solar radiation and ambient temperature measured at Helwan city, Egypt. A comparison between ABC algorithm and Genetic Algorithm (GA) optimal results is done. Another location is selected which is Zagazig city to check the validity of ABC algorithm in any location. The ABC is more optimal than GA. The results encouraged the use of the PV systems to electrify the rural sites of Egypt.

© 2013 Production and hosting by Elsevier B.V. on behalf of Cairo University.

Introduction

Photovoltaic (PV) system has received a great attention as it appears to be one of the most promising renewable energy sources. The absence of an electrical network in remote areas leads the organizations to explore alternative solutions such

as stand-alone power system. The performance of a stand-alone PV system depends on the behavior of each component and on the solar radiation, size of PV array, and storage capacity. Therefore, the correct sizing plays an important role on the reliability of the stand-alone PV systems. There are classified as intuitive methods, numerical methods, and analytical methods. The first group algorithms are very inaccurate and unreliable. The second is more accurate, but they need to have long time series of solar radiation for the simulations. In the third group, there are methods which use equations to describe the PV system size as a function of reliability. Many of the analytical methods employ the concept of reliability of the system or the complementary term: loss of load probability (LLP). A review of sizing methods of stand-alone PV system has been presented by Shrestha and Goel [1], which is based on energy generation simulation for various numbers of PVs and batteries

\* Corresponding author. Tel.: +20 2 55 3725918; fax: +20 2 55 230498.

E-mail addresses: [elmohandes.ahmed@gmail.com](mailto:elmohandes.ahmed@gmail.com), [ahmed\\_fathy\\_1984@yahoo.com](mailto:ahmed_fathy_1984@yahoo.com) (A.F. Mohamed).

Peer review under responsibility of Cairo University.

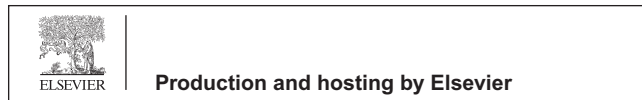

using suitable models for the system devices (PVs, batteries, etc.). The selection of the numbers of PVs and batteries ensures that reliability indices such as the Loss of Load Hours (LOLH), the lost energy and the system cost are satisfied. In a similar method, Maghraby et al. [2] used Markov chain modeling for the solar radiation. The number of PVs and batteries is selected depending on the desired System Performance Level (SPL) requirement, which is defined as the number of days that the load cannot be satisfied, and it is expressed in terms of probability. An optimization approach in which the optimal number and type of units ensuring that the 20-year round total system cost is minimized was presented by Koutroulis et al. [3], and the proposed objective function is subjected to the constraint that the load energy requirements are completely covered, resulting in zero load rejection. The drawback of this technique is that the power produced by the PV and WG power sources is assumed to be constant during the analysis time period. An optimal approach for sizing both solar array and battery in a stand-alone photovoltaic (SPV) system based on the loss of power supply probability (LPSP) of the SPV system was given by Lalwani et al. [4]. An economic analysis on a solar based stand-alone PV system to provide the required electricity for a typical home was presented by Abdulateef et al. [5]. An intelligent method of optimal design of PV system based on optimizing the costs during the 20-year operation system was presented by Javadi et al. [6]. A methodology for designing a stand-alone photovoltaic (PV) system to provide the required electricity for a single residential household in India was introduced by Kirmani et al. [7] in which the life cycle cost (LCC) analysis is conducted to assess the economic viability of the system. A technique for PV system size optimization based on the probabilistic approach was presented by Arun et al. [8]. An optimization technique of PV system for three sites in Europe in which optimization considers sizing curves derivation and minimum storage requirement was proposed by Fragaki and Markvart [9]. An analytical method for sizing of PV systems based on the concept of loss of load probability was presented by Posadillo and Luque [10], in this method, the standard deviation of loss of load probability and another two new parameters, annual number of system failures and standard deviation of annual number of failures are considered, and the optimization of PV array tilt angle is also presented to maximize the collected yield. The previous literature methods have some drawbacks such as

1. The design is based on insufficient database of the devices; as only two types of PV modules, batteries and controller were suggested by Koutroulis et al [3].
2. The design is based on the instantaneous PV module power which is not practical point as the design must be based on the worst case which is the maximum power extracted from the module.

The bee colony system and its demonstration of the features are discussed by Karaboga and Akay [11]; additionally, it sum-

marized the algorithms simulating the intelligent behaviors in the bee colony and their applications. ABC has been used to solve many problems from different areas successfully [12]. It has been used to solve certain bench mark problems like Traveling Salesman Problem, routing problems, NP-hard problems. A comprehensive comparative study on the performances of well-known evolutionary and swarm-based algorithms for optimizing a very large set of numerical functions was presented [13]. Another application for ABC was introduced by Karaboga and Ozturk [14]. It is used for data clustering on bench mark problems, and the performance of ABC algorithm is compared with Particle Swarm Optimization (PSO) algorithm. Artificial Bee Colony Programming was described as a new method on symbolic regression which is a very important practical problem [15]. Symbolic regression is a process of obtaining a mathematical model using given finite sampling of values of independent variables and associated values of dependent variables. A set of symbolic regression bench mark problems are solved using Artificial Bee Colony Programming, and then, its performance is compared with the very well-known method evolving computer programs, genetic programming. According to the various applications of ABC algorithm, it can be applied to solve the proposed difficult design optimization problem.

In this paper, a new Evolutionary Technique for optimizing a stand-alone PV system is presented. The technique aims to maximize the output electrical power of the PV module and minimize the life cycle cost (LCC). It is based on two proposed objective function subjected to constraints; either equality or inequality constraints. Firstly, dummy variables of the PV system operation are classified into two categories: dependent and independent variables. The independent variables are those that do not depend on any variable of solar module operation, while the dependant variables are those controlled by independent one. Secondly; the Artificial Bee Colony Algorithm (ABC) is used to solve the optimization problem [16]. Finally; a comparison between ABC solution and Genetic Algorithm (GA) solution is performed. The proposed technique is applied to Helwan city at latitude 29.87°, Egypt, and to ensure the validity of ABC algorithm, the methodology is repeated for Zagazig city. The results showed that the proposed constrained optimization method is efficient and applicable for any location.

### Mathematical model of PV system

The PV system comprises PV array, battery bank, battery charger controller, and DC/AC inverter as shown in Fig. 1.

#### PV module

In this section, a model of the PV module is presented. The total rate of radiation  $G_C$  striking a PV module on a clear day can be resolved in to three components [17]; direct beam,  $G_{BC}$ , diffuse,  $G_{DC}$ , and reflected beam,  $G_{RC}$ .

$$G_C = G_{BC} + G_{DC} + G_{RC} \quad (1)$$

$$G_C = Ae^{-km} \left[ \cos \beta \cos (\varphi_s - \varphi_c) \sin \Sigma + \sin \beta \cos \Sigma + C \left( \frac{1 + \cos \Sigma}{2} \right) + \rho (\sin \beta + C) \left( \frac{1 - \cos \Sigma}{2} \right) \right] \quad (2)$$

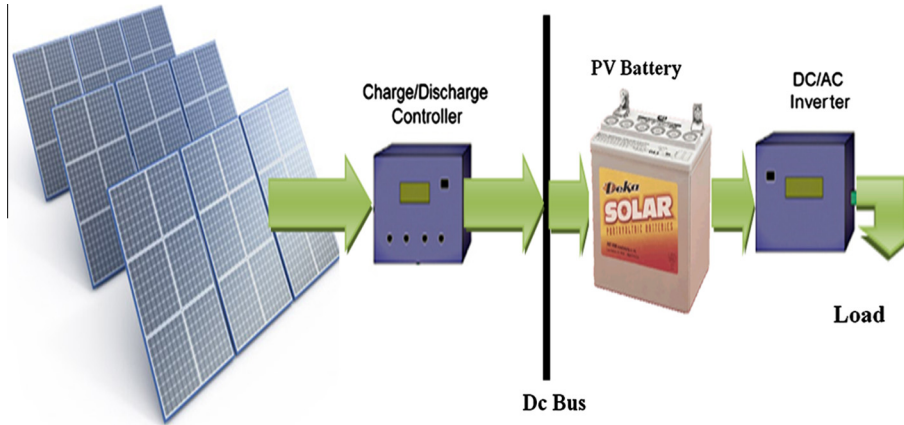

Fig. 1 Block diagram of proposed PV system.

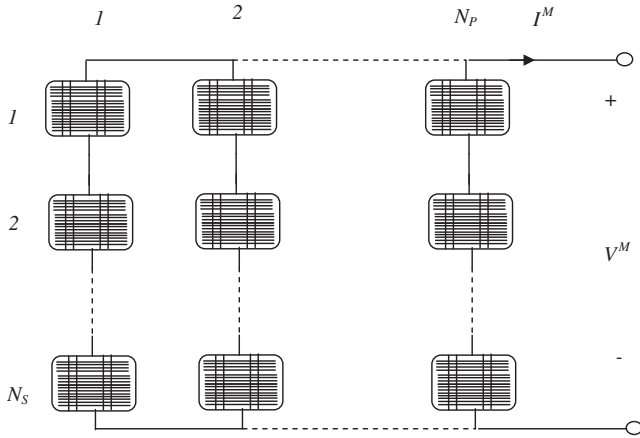

Fig. 2 The equivalent circuit for a PV module.

$$m = \frac{h_2}{h_1} = \frac{1}{\sin \beta} \quad (3)$$

where  $m$  is the air mass,  $\beta$  is the altitude angle,  $\varphi_s$  is the solar azimuth angle,  $\varphi_c$  is the PV module azimuth angle,  $\Sigma$  is the PV module tilt angle,  $\rho$  is the reflection factor,  $C$  is the sky diffuse factor, and  $A$  and  $k$  are parameters dependent on the Julian day number [1].

$$C = 0.095 + 0.04 \sin \left[ \frac{360}{365} (d - 100) \right] \quad (4)$$

$$A = 1160 + 75 \sin \left[ \frac{360}{365} (d - 275) \right] (\text{W/m}^2) \quad (5)$$

$$k = 0.174 + 0.035 \sin \left[ \frac{360}{365} (d - 100) \right] \quad (6)$$

where  $d$  is the day number. The PV module consists of  $N_s$  of series cells and  $N_p$  of parallel branches as shown in Fig. 2.

A PV module's current  $I^M$  can be described as follows [18]:

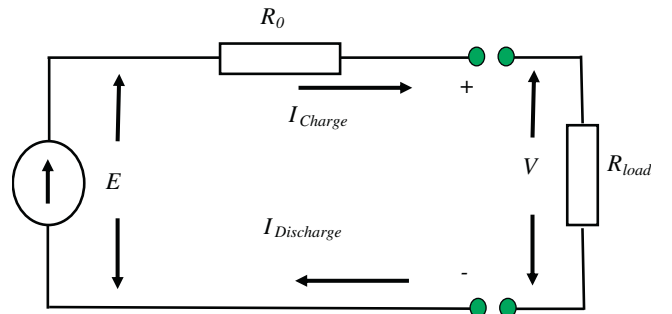

Fig. 3 Schematic diagram of the battery.

$$I^M = N_p I_{SC} - N_p I_0 \left\{ \exp \left[ \frac{q \left( \frac{V^M}{N_s} + I^M \cdot R_s^M \right)}{nk_b T_c} \right] - 1 \right\} - \left( \frac{V^M + I^M \cdot R_s^M}{R_p^M} \right) \quad (7)$$

$$\text{And } R_s^M = \frac{N_s}{N_p} R_s^C, R_p^M = \frac{N_p}{N_s} R_p^C \text{ and } V^M = N_s V^C \quad (8)$$

where  $I_{SC}$  is the PV module short circuit current,  $I_0$  is the reverse diode saturation current,  $V^C$  is the cell voltage,  $V^M$  is module voltage,  $R_s^C$  is the cell series resistance,  $R_p^C$  is the cell parallel resistance,  $R_s^M$  is the module series resistance,  $R_p^C$  is the module parallel resistance,  $n$  is the diode ideality factor,  $k_b$  is the Boltzmann constant ( $1.38e^{-23}$  J/K), and  $T_c$  is the cell junction temperature ( $^{\circ}\text{C}$ ) that is calculated as follows:

$$T_c = T_a + \left( \frac{NOCT - 20^{\circ}}{0.8} \right) * G_C \quad (9)$$

where  $T_a$  is the ambient temperature and  $NOCT$  is cell temperature in a module when ambient temperature is  $20^{\circ}\text{C}$ .

#### Battery

In general, a PV battery can be modeled as a voltage source,  $E$ , in series with an internal resistance,  $R_0$ , as shown in Fig. 3. The terminal voltage  $V$  is given as follows [17]:

$$V = E - IR_0 \quad (10)$$

## The proposed methodology

The proposed technique is based on two objective functions: the first describes the PV module output Power and the second describes the LCC of the PV system. Each proposed objective function has some constraints.

### The proposed objective function of the PV module power

The main object of this section is to extract a possible maximum power from a PV module based on a proposed objective function of the power which subjected to constraints; the proposed objective function is obtained as follows: During the operation of the PV module, there are some variables that control the operation. Initially, these dummy variables are classified into two categories: independent or control variables ( $U$ ) and their corresponding dependant variables ( $X$ ). The proposed two vectors are as follows:  $U = [N_s, N_p, d, \Sigma, \varphi_C]$  and  $X = [\beta, m, \varphi_S, G_C, I_{SC}, I_0, T_c]$ . The proposed objective function is expressed in the following form:

$$\begin{aligned} \text{maximize } P_{pv}^{i(max)}(t, \Sigma_{opt}) &= f(T_c, V^M, m, \Sigma, \varphi_C, \beta, L, \omega, G_C, I_0) = (N_s V^C)_{n+1}^M \\ &= V^M \left( I_n^M * \left( 1 - \frac{1}{1 + \psi(T_c) * (1 - \mu(V^M, T_c, I^M)) * \partial(T_c)} \right) \right. \\ &\quad \left. + \frac{\psi(T_c) * (m, \varphi_S, \beta, \Sigma, \varphi_C) * \mu(V^M, T_c, I^M) + \gamma(V^M)}{1 + \psi(T_c) * (1 - \mu(V^M, T_c, I^M)) * \partial(T_c)} \right) \end{aligned} \quad (11)$$

where  $P_{pv}^{i(max)}(t, \Sigma_{opt})$  is the maximum PV module output power at optimal tilt angle  $\Sigma_{opt}$  and hour  $t$  during a day no.  $i$ ,  $L$  is the latitude,  $\psi(T_c)$ ,  $\mu(V^M, T_c, I^M)$ ,  $\mu(V^M, T_c, I^M)$ ,  $\partial(T_c)$ ,  $\varepsilon(m, \varphi_S, - (V^M, T_c, I^M))$ ,  $\partial(T_c)$ ,  $\varepsilon(m, \varphi_S, \beta, \Sigma, \varphi_C)$ , and  $\gamma(V^M)$  are nonlinear functions, each related to its corresponding variables. The proposed parametric constrains are as follows:

$$\begin{aligned} d^{min} < d < d^{max} &\rightarrow 1 \leq d \leq 365 \\ \Sigma^{min} < \Sigma < \Sigma^{max} &\rightarrow 0 \leq \Sigma \leq 80 \\ \varphi_C^{min} < \varphi_C < \varphi_C^{max} &\rightarrow -45 \leq \varphi_C \leq 45 \end{aligned} \quad (12)$$

The proposed equality constraint is given as

$$g(U, X) = V_{oc} - 184.0293 * \frac{N_s V^C}{T_c} = 0 \quad (13)$$

The limits of independent variables are selected according to the following aspects:

1. When  $\Sigma = 0^\circ$ , the module becomes horizontal and produces power while when  $\Sigma = 90^\circ$ ; the module becomes vertical and produces zero power; so the selected limits are assumed between  $0^\circ$  and  $80^\circ$ .
2. The solar azimuth angle is positive for east of south, and becomes negative for west of south; so the limits are selected as  $\pm 45^\circ$ .

The total power,  $P_{re}^i(t)$ , transferred to the battery bank from the PV array during day  $i$  and hour  $t$  is calculated as follows:

$$P_{re}^i(t) = N_{pv} * P_{pv}^{i(max)}(t, \Sigma_{opt}) \quad (14)$$

where  $N_{pv}$  is the total number of PV modules used in the array. Then, the DC/AC inverter input power,  $P_L^i(t)$ , is calculated using the corresponding load power requirements, as follows:

$$P_L^i(t) = \frac{P_{load}^i(t)}{\xi_{inv}} \quad (15)$$

where  $P_{load}^i(t)$  is the power consumed by the load at hour  $t$  of day  $i$ , defined at the beginning of the optimal sizing process and  $\xi_{inv}$  is the inverter efficiency. According to the above power production and load consumption calculations, the resulting battery capacity is calculated.

- If  $P_{re}^i(t) = P_L^i(t)$  then the battery capacity remains unchanged.
- If  $P_{re}^i(t) > P_L^i(t)$  then the power surplus  $P_B^i(t) = P_{re}^i(t) - P_L^i(t)$  is used to charge the battery bank, and the new battery capacity is calculated as following.

$$C^i(t) = C^i(t-1) + \frac{P_B^i(t) * \Delta t * \xi_{bat}}{V_{Bus}} \quad 1 \leq t \leq 24 \quad (16)$$

where  $C^i(t)$ ,  $C^i(t-1)$  is the available battery capacity (Ah) at hour  $t$  and  $t-1$ , respectively, of day  $i$ ,  $\xi_{bat} = 80\%$  is the battery round-trip efficiency during charging and  $\xi_{bat} = 100\%$  during discharging [19],  $V_{Bus}$  is the DC bus voltage,  $P_B^i(t)$  is the battery input/output power, and  $\Delta t$  is the simulation time step, set to  $\Delta t = 1h$ . At any hour, the storage capacity is subject to the following constraints:

$$C_{min} \leq C^i(t) \leq C_{max} \quad (17)$$

where  $C_{max}$ ,  $C_{min}$  are the maximum and minimum allowable storage capacities. Using for  $C_{max}$  the storage nominal capacity, then  $C_{min} = DOD * C_n$ ;  $C_n$  as is the nominal capacity of battery. The number of PV modules connected in series in the PV array,  $n_{pv}^s$ , depends on the battery charger maximum input voltage which is equal to the dc bus voltage,  $V_{Bus}$  (V), and the PV modules maximum power corresponding voltage  $V_{MP}$  (V), the relation is given below.

$$n_{pv}^s = \frac{V_{Bus}}{V_{MP}} \quad (18)$$

The number of batteries connected in series,  $n_b^s$ , depends on the nominal DC bus voltage and the nominal voltage of each individual battery,  $V_b$ , and it is calculated as follows:

$$n_b^s = \frac{V_{Bus}}{V_b} \quad (19)$$

The number of battery chargers,  $N_{ch}$ , depends on the total number of PV modules.

$$N_{ch} = \frac{N_{pv} * P_m}{P_{mc}} \quad (20)$$

where  $P_m$  is the maximum power of one module under *STC* and  $P_{mc}$  is the power rating of battery charger.

### The proposed LCC objective function

This section presents the second objective function of the PV system life cycle cost which is required to be minimized to obtain the best numbers of PV modules, batteries, and chargers with minimum (optimal) cost.

The total PV system cost function is equal to the sum of the total capital  $C_c(u)$ , maintenance cost  $C_m(u)$  (\$), functions.

$$\min\{J(u)\} = \min\{C_c(u) + C_m(u)\} \quad (21)$$

where  $u$  is a set of the cost independent variables which are the total number of PV modules and the total number of batteries. The total

number of battery chargers is calculated after calculating the optimal value of  $u$  variables. Thus, the multi-objective optimization is achieved by minimizing the total cost function consisting of the sum of individual system cost devices capital cost and 20-year round maintenance cost. The proposed life time cost objective function is:

$$\begin{aligned}
 J(u) = & \left( \frac{\sum_{i=1}^{N_{PV}} i(C_{PV_i} + 20 \cdot M_{PV_i})}{L \cdot T_{PV}} \right) \\
 & + \left( \frac{\sum_{j=1}^{N_{BAT}} j \cdot C_{BAT_j} (1 + y_{BAT_j} + M_{BAT_j} \cdot (20 - y_{BAT_j}))}{L \cdot T_{BAT}} \right) \\
 & + \left( \frac{\sum_{l=1}^{N_{CH}} l \cdot C_{CH_l} (1 + y_{NCH_l} + M_{NCH_l} \cdot (20 - y_{NCH_l}))}{L \cdot T_{CH}} \right) \\
 & + \left( \frac{C_{Inv} (1 + y_{Inv} + M_{Inv} \cdot (20 - y_{Inv}))}{L \cdot T_{Inv}} \right)
 \end{aligned}
 \tag{22}$$

Subject to  $N_{PV} \geq 0$

$$N_{BAT} \geq 0 \tag{23}$$

where  $L \cdot T_{PV}$ ,  $L \cdot T_{BAT}$ ,  $L \cdot T_{CH}$ ,  $L \cdot T_{Inv}$  are the year life time for PV module, battery, battery charger and the inverter respectively,  $u = [N_{PV}, N_{BAT}]$ ,  $C_{PV}$  and  $C_{BAT}$  are the capital costs (\$) of one PV module, and battery, respectively,  $M_{PV}$ , and  $M_{BAT}$  are the maintenance costs per year (\$/year) of one PV module and battery, respectively,  $C_{ch}$  is the capital cost of one battery charger (\$),  $y_{ch}$ ,  $y_{inv}$  are the expected numbers of the battery charger and DC/AC inverter replacements during the 20-year system lifetime and are assumed to be equal 4,  $C_{inv}$  is the capital cost of the inverter, (\$),  $y_{BAT}$  is the expected number of battery replacements during the 20-year system operation, because of limited battery lifetime,  $M_{ch}$ ,  $M_{inv}$  are maintenance costs per year (\$/year) of one battery charger and DC/AC inverter, respectively. Maintenance cost of each

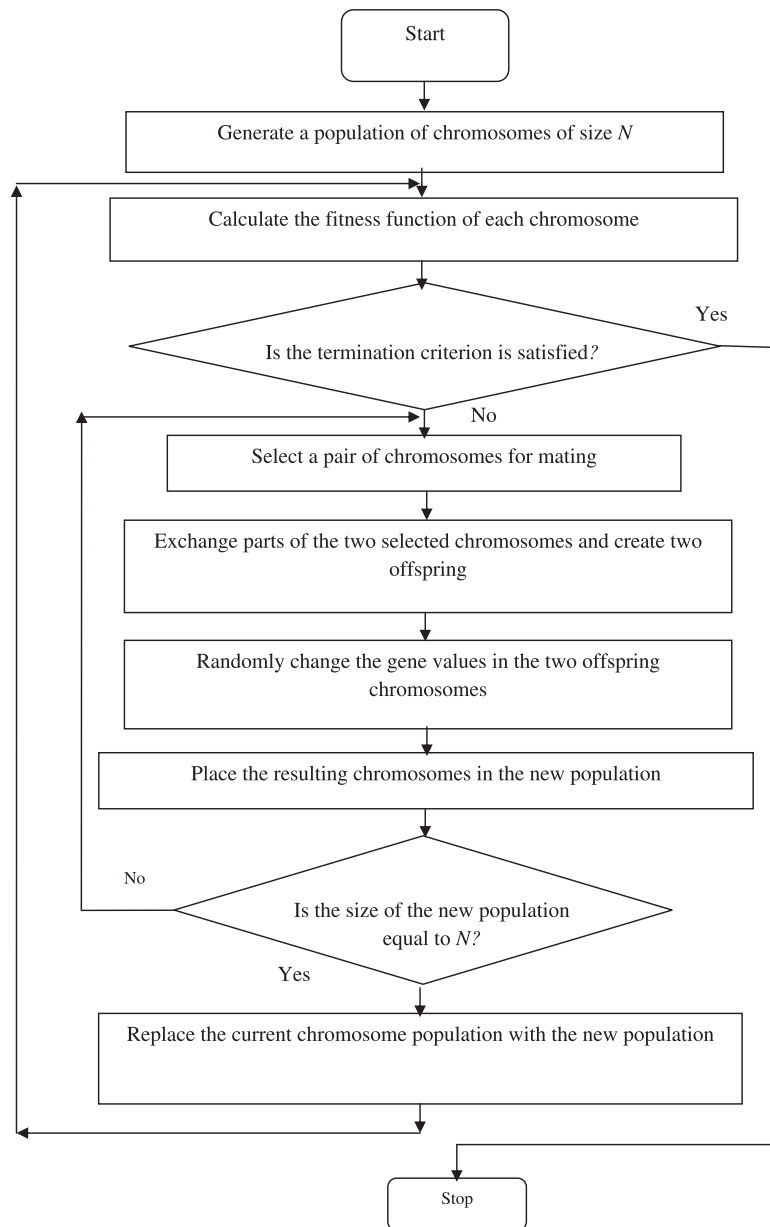

Fig. 4 A simple genetic algorithm flow chart.



unit per year has been assumed 1% of the corresponding capital cost. The total optimal number of PV modules,  $N_{PV}$ , and the total optimal number of batteries  $N_{BAT}$  are calculated by minimizing the objective function of cost. Then, the number of parallel strings  $n_{pv}^p$  and the number of batteries connected in parallel  $n_b^p$  can be calculated using the following formulas;

$$n_{pv}^p = \frac{N_{pv}}{n_{pv}^s} \quad (24)$$

$$n_b^p = \frac{N_{BAT}}{n_b^s} \quad (25)$$

So, the optimal number and optimal configuration for the PV system components are obtained. The different combinations of PV modules, batteries, and chargers are studied, and the optimal cost of each case is calculated from Eq. (22), then the minimum cost is selected, and the corresponding combination are obtained.

#### Genetic algorithm

The term genetic algorithm, almost universally abbreviated nowadays to GA, was first used by Holland [20]. GAs in their original form summarized most of what one needs to know. Genetic Algorithm (GA) is gradient-free, parallel optimization algorithms that use a performance criterion for evaluation and a population of possible solutions to the search for a global optimum. GA is capable of handling complex and irregular solution spaces, and they have been applied to various difficult optimization problems. The manipulation is done by the *genetic operators* that work on the *chromosomes* in which the parameters of possible solutions are encoded. The main elements of GAs are populations of chromosomes, selection according to fitness, crossover to produce new offspring, and random mutation of new offspring. The simplest form of genetic algorithm

involves three types of operators: selection, crossover, and mutation. A simple GA flow chart is shown in Fig. 4. The used form of genetic algorithm involves three types of operators: selection, crossover (single point), and mutation.

*Selection:* This operator selects chromosomes in the population for reproduction. The fitter the chromosome, the more times it is likely to be selected to reproduce.

*Crossover:* This operator randomly chooses a locus and exchanges the subsequences before and after that locus between two chromosomes to create two offspring. The crossover operator roughly mimics biological recombination between two single chromosome organisms.

*Mutation:* This operator randomly flips some of the bits in a chromosome. Typically, a chromosome is structured by a string of values in binary form, which the mutation operator can operate on any one of the bits, and the crossover operator can operate on any boundary of each two bit in the string. Here, the mutation can change the value of a real number randomly, and the crossover can take place only at the boundary of two real numbers. The control parameters of GA are assumed as; the proposed mutation function is mutation adapt feasible, the population size is assumed to be 100; the number of generation is assumed to be 200.

#### Artificial Bee Colony Algorithm

Artificial Bee Colony (ABC) is one of the most recently defined algorithms by Dervis Karaboga in 2005 [16], motivated by the intelligent behavior of honey bees. ABC as an optimization tool provides a population based search procedure in which individuals are foods positions are modified by the artificial bees with time, and the bee's aim is to discover the places of food sources with high nectar amount and finally the one with the highest nectar. The ABC algorithm steps are summarized as follows:

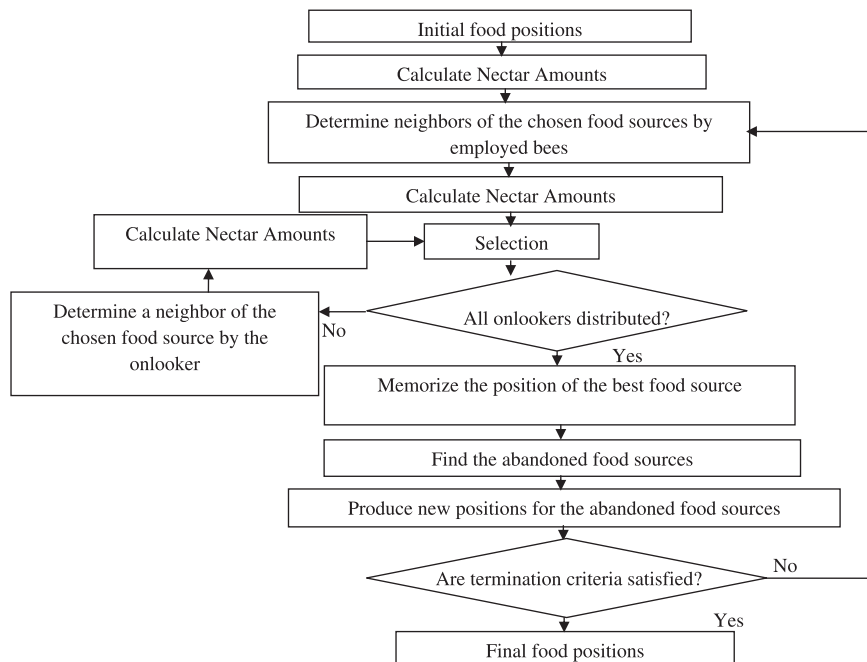

Fig. 5 Artificial Bee Colony Algorithm flow chart.

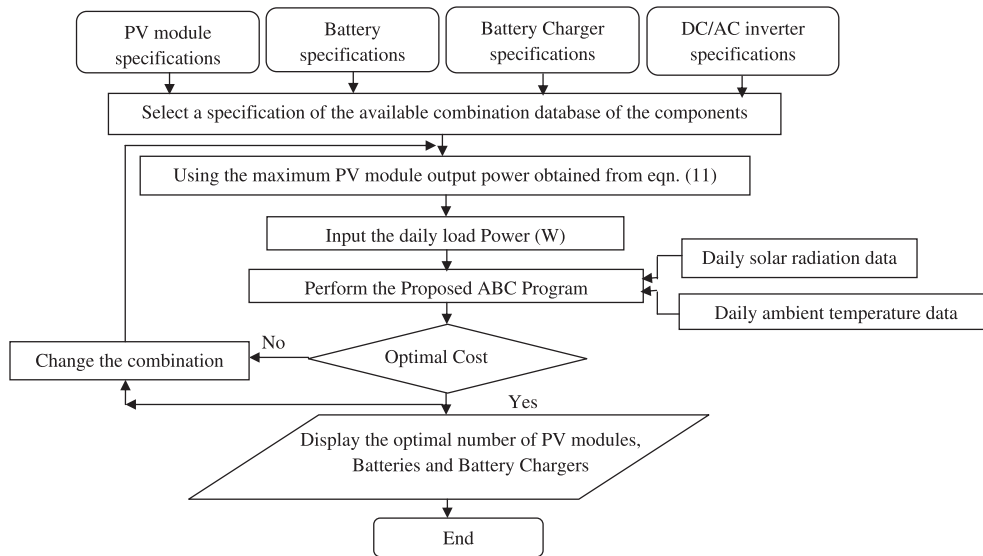

Fig. 6 Flow chart of the proposed PV sizing optimization methodology.

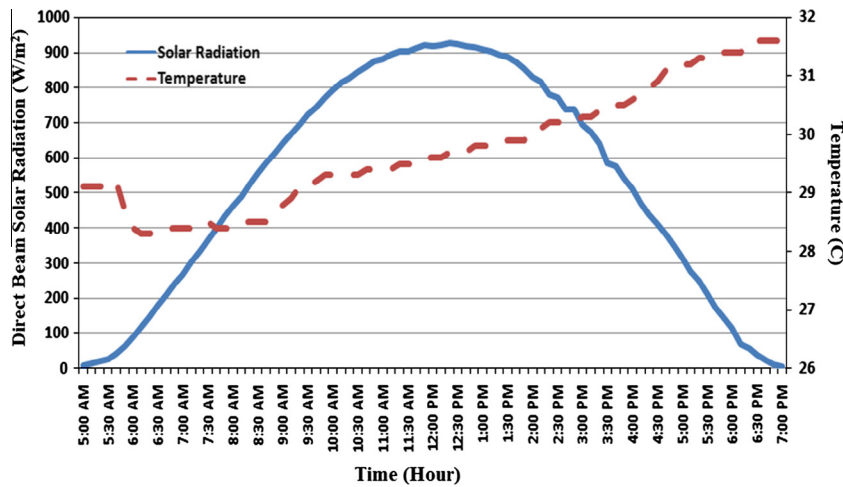

Fig. 7 Measured solar radiation and ambient temperature.

- Initial food sources are produced for all employed bees.
- Repeat the following items;
  1. Each employed bee goes to a food source in her memory and determines a neighbor source, then evaluates its nectar amount and dances in the hive.
  2. Each onlooker watches the dance of employed bees and chooses one of their sources depending on the dances, and then goes to that source. After choosing a neighbor around that, she evaluates its nectar amount.
  3. Abandoned food sources are determined and are replaced with the new food sources discovered by scouts.
  4. The best food source found so far is registered.
- UNTIL (requirements are met).

The flow chart shown in Fig. 5 gives detailed steps that are followed in the ABC algorithm. Fig. 6 shows the steps of the proposed PV sizing optimization methodology. The optimiza-

tion algorithm input is fed by a database containing the technical characteristics of commercially available system devices along with their associated per unit capital and maintenance costs. Various types of PV modules, batteries with different nominal capacities, etc., are stored in the input database.

The control parameters of ABC algorithm are assumed as follows:

- The number of colony size (employed bees and onlooker bees) is assumed to be 20.
- The number of food sources equals the half of the colony size.
- The limit is assumed to be 100. A food source which could not be improved through “limit” trials is abandoned by its employed bee.
- The number of cycles for foraging is assumed to be 1000.

These controlled values are selected as the possible minimum cost is obtained at these values.

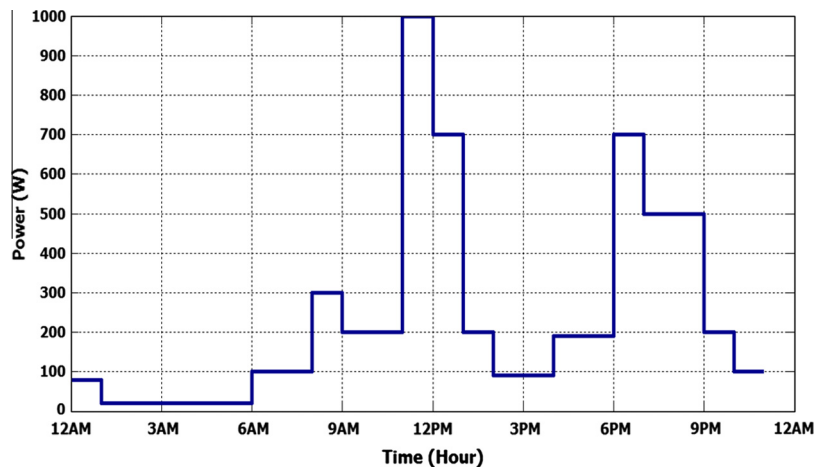

Fig. 8 Distribution of the consumer power requirements during the day.

**Table 1** The specifications of the PV system devices.

Type	Power rating (W)	Capital cost (\$)	Maintenance cost per year (\$/year)		
<i>PV module specifications</i>					
1. CS5C-90	90	450	4.50		
2. Bpsx150	150	750	7.50		
3. CS6P-200	200	1000	10.00		
4. CHSM6610M-235	235	1175	11.75		
5. IM72C3-310-T12B45	310	1550	15.50		
Type	Nominal capacity (Ah)	Voltage (V)	DOD (%)	Capital cost (\$)	Maintenance cost per year (\$/year)
<i>Batteries specifications</i>					
1	230	12	80	341	3.41
2	100	12	80	163	1.63
3	150	12	80	256	2.56
4	300	6	80	512	5.12
5	420	6	80	716	7.16
Type	Power rating (W)	Capital cost (\$)	Maintenance cost per year (\$/year)		
<i>PV battery chargers specifications</i>					
1	300	259	2.59		
2	240	121.5	1.215		
3	288	140	1.4		
4	120	198	1.98		
5	1152	289	2.89		
1	300	259	2.59		
Type	Efficiency (%)	Power rating (W)	Capital cost (\$)	Maintenance cost per year (\$/year)	
<i>DC/AC inverter specifications</i>					
1	80	1500	2510	25.10	

## Results and discussions

The analysis of the proposed algorithm is performed on a real data for direct beam solar radiation and ambient temperature measured by solar radiation and meteorological station located at National Research Institute of Astronomy and Geophysics Helwan, Cairo, Egypt, located at latitude 29.87°N and longitude 31.30°E. The station is over a hill top of about 114 m height above sea level. Example of The daily recorded

measured solar radiation is shown in Fig. 7. The data are recorded for the sunny day of June 10, 2012 start from hour 6:10 AM to hour 5:50 PM. The distribution of the consumer power requirements during a day is shown in Fig. 8; the total energy demand per day for the load is equal to 5.56 kW h/day. The technical characteristics and the related capital and maintenance costs of the PV system devices, which are used, are shown in Table 1. The expected battery lifetime has been set at 3 years resulting in  $y_{BAT} = 6$  for 20 year. The expected re-



**Table 2** The optimal power extracted from the proposed PV modules.

Hour	CS5C-90		Bpsx150		CS6P-200		CHSM6610M-235		IM72C3-310-T12B45	
	$\Sigma_{opt}$	$P_{opt}$	$\Sigma_{opt}$	$P_{opt}$	$\Sigma_{opt}$	$P_{opt}$	$\Sigma_{opt}$	$P_{opt}$	$\Sigma_{opt}$	$P_{opt}$
6:10 AM	73.5	13.6	75.75	19.9	73.5	31.8	73.5	36.4	73.5	45.9
7:00 AM	62.2	30.7	63.5	50.1	62.2	71.8	62.2	82.3	62.2	103.8
8:00 AM	47.6	52.8	47.3	84.8	47.5	123.6	47.5	141.7	47.5	178.7
9:00 AM	32.6	75.3	36.9	137.1	32.6	176.1	32.6	201.9	32.6	254.7
10:00 AM	23.3	98.5	28.3	182.8	23.34	230.3	23.3	264.0	23.3	333.1
11:00 AM	14.7	113.1	19.2	225.1	14.8	264.5	14.7	303.3	14.7	382.6
12:00 PM	7.2	118.3	13.0	226.6	7.2	276.5	7.2	317.0	7.2	399.9
1:00 PM	14.7	116.6	19.3	217.2	14.6	272.6	14.7	312.6	14.8	394.3
2:00 PM	23.3	103.1	28.2	194.0	23.3	241.0	23.3	276.4	23.5	348.7
3:00 PM	32.6	81.3	36.7	153.8	32.6	190.0	32.6	217.9	32.6	274.9
4:00 PM	49.3	58.5	47.8	98.8	47.6	136.9	47.7	157.0	47.8	198.1
5:00 PM	62.3	35.9	63.5	56.6	62	84.1	62.27	96.4	62.2	121.6
5:50 PM	73.6	16.3	75.8	20.3	73.6	38.2	73.6	43.9	73.6	55.3

**Table 3** A comparison between the optimal cost of the proposed technique and the method proposed by Koutroulis et al. [3].

Study cases	Device type			Technique proposed by Koutroulis et al. [3]				Proposed technique by GA				%Cost reduction
	PV	Charger	Battery	Optimal no. of PV	Optimal no. of batteries	Optimal no. of charger	Optimal cost (\$/wh)	Optimal no. of PV	Optimal no. of batteries	Optimal no. of charger	Optimal cost (\$/wh)	
Case (1)	1	1	1	13	16	6	12.8653	10	12	5	10.1647	-0.1897861
Case (2)	1	1	2	13	40	6	14.2297	11	36	6	11.7964	-0.1710015
Case (3)	1	2	1	13	16	8	12.3263	12	12	7	9.7692	-0.1797016
Case (4)	1	2	2	13	40	8	13.6906	15	32	9	10.7752	-0.2048813
Case (5)	2	1	1	8	16	6	12.7897	9	16	7	11.9896	-0.0562274
Case (6)	2	1	2	8	40	6	14.1541	7	32	5	10.9291	-0.2266386
Case (7)	2	2	1	8	16	7	12.1381	7	16	6	10.0856	-0.1442405
Case (8)	2	2	2	8	40	7	13.5025	8	40	7	11.5752	-0.1354420

**Table 4** A comparison between GA and ABC optimal cost @ Helwan city.

Study cases	Device type	Genetic algorithm solution						ABC Algorithm Solution				% Error
		Battery (Ah)	Charger (W)	$N_{PV}$	$N_{Batt}$	$N_{Ch}$	Cost (\$/wh)	$N_{PV}$	$N_{Batt}$	$N_{Ch}$	Cost (\$/wh)	
Case (5)	CS5C-90	230	1152	12	12	1	7.0237	11	10	1	7.0189	-0.04559
Case (30)	Bpsx150	230	1152	9	16	1	9.6621	10	13	1	8.3583	-13.5071
Case (55)	CS6P-200	230	1152	6	20	1	10.5286	5	18	1	10.5178	-0.11204
Case (80)	CHSM6610M-235	230	1152	6	16	1	9.6527	4	15	1	9.2027	-4.27407
Case (105)	IM72C3-310-T12B45	230	1152	3	16	1	9.6394	3	15	1	9.2022	-4.1525

placed number of both charger and inverter is  $y_{ch} = y_{inv} = 4$ . The bus voltage is assumed to be 48 V. First, the optimal power and corresponding tilt angle for each suggested that PV module is obtained in Table 2 using GA program. One can derive that the obtained maximum powers are 118.2689, 226.6207, 276.4720, 317.0012, and 399.9663 for each type of PV system, respectively. All maximum powers occur at 12:00 PM. To investigate the advantages of the proposed technique, the obtained results are compared to techniques proposed by Koutroulis et al. [3] based on the measured solar radiation data for Helwan city. The comparison is given in Tables 3. The PV module of type 1 is considered Bpsx150, the PV module of type 2 is considered CHSM6610M-235,

the battery of type 1 is 230 Ah, the battery of type 2 is 100 Ah, the charger of type 1 is 300 W, and the charger of type 2 is 240 W.

According to the proposed technique by Koutroulis et al. [3], the optimal operating case is case (7) which comprises 8 modules of CHSM6610M-235 PV module, 16 batteries of the second type of battery which has nominal capacity of 100 Ah, and 7 chargers of the first type of the battery charger of power rating of 300 W. The optimal cost is 67,488 \$ which lead to 12.1381 \$/wh. According to the proposed technique, the optimal case is case (3) which comprises 12 modules of Bpsx150PV module, 12 batteries of the second type of battery which has nominal capacity of 100 Ah, and 7 chargers of the

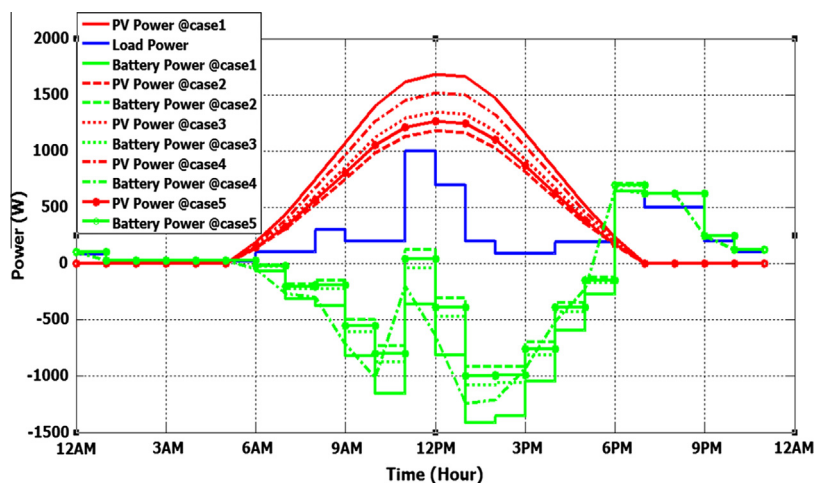

Fig. 9 PV array power, battery power, and load power for the first five cases.

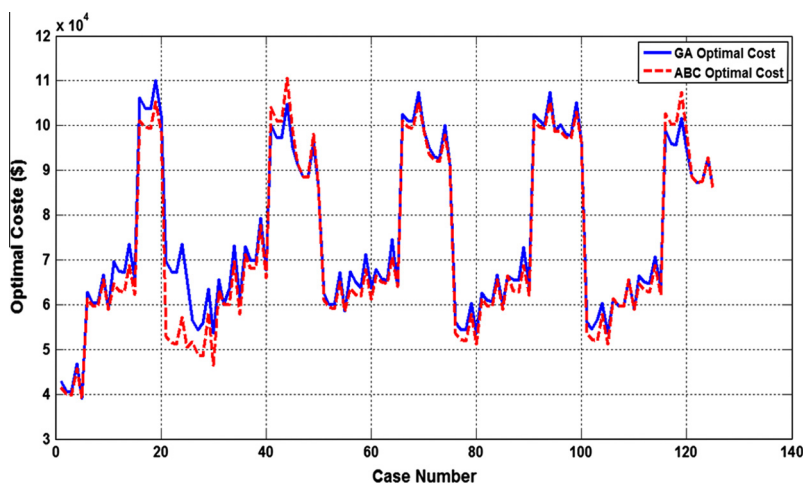

Fig. 10 A comparison between GA and ABC optimal cost.

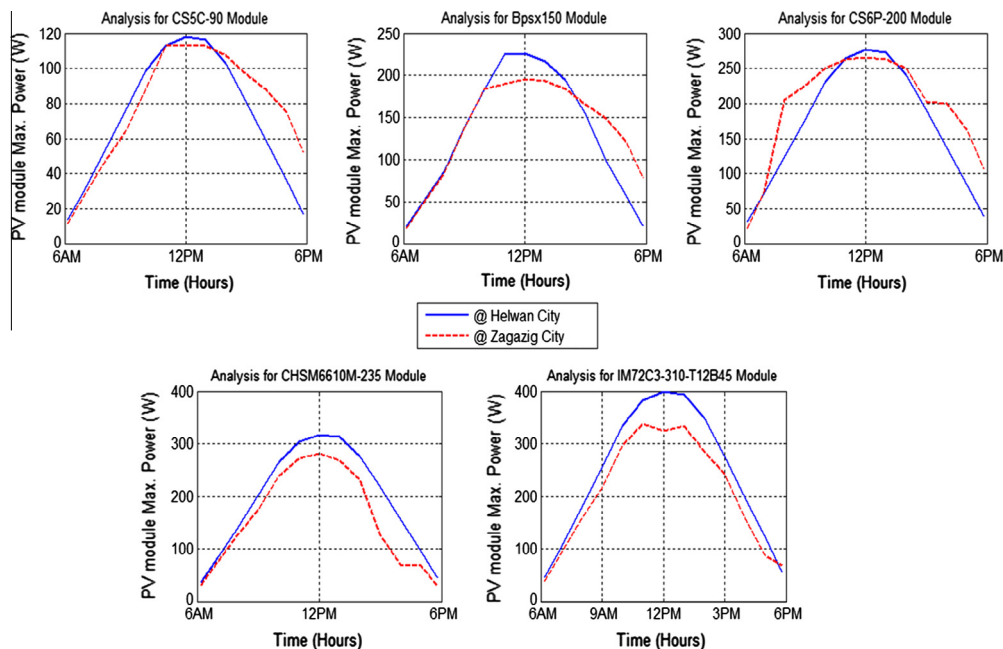
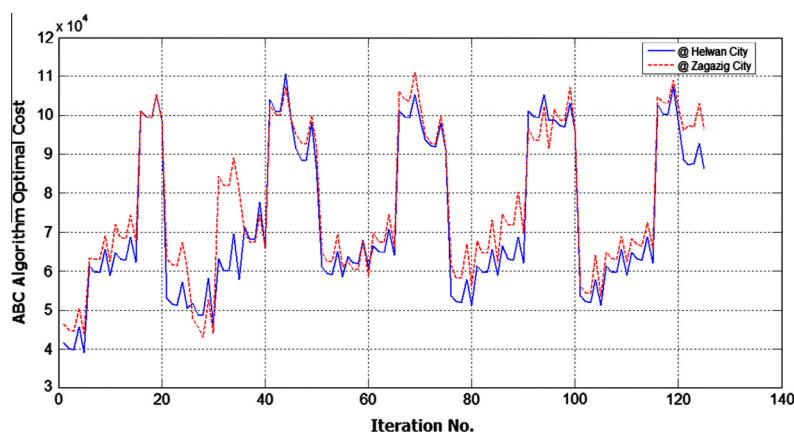

Fig. 11 A comparison of the maximum power extracted from each module for two locations.

**Table 5** A comparison between GA and ABC optimal cost @ Zagazig city.

Study cases	Device type PV module type	Genetic algorithm solution						ABC Algorithm Solution				% Error
		Battery (Ah)	Charger (W)	$N_{PV}$	$N_{Batt}$	$N_{Ch}$	Cost (\$/wh)	$N_{PV}$	$N_{Batt}$	$N_{Ch}$	Cost (\$/wh)	
Case (5)	CS5C-90	230	1152	13	14	1	8.7777	11	12	1	7.8935	-8.0089
Case (28)	Bpsx150	230	288	10	14	5	9.1763	7	11	4	7.7104	-13.2775
Case (60)	CS6P-200	100	1152	8	40	1	11.0399	6	38	1	10.6004	-3.9816
Case (80)	CHSM6610M-235	230	1152	6	16	1	10.5525	6	17	1	10.1025	-4.0761
Case (105)	IM72C3-310-T12B45	230	1152	4	17	1	10.0933	3	16	1	9.6394	-4.1120

**Fig. 12** A comparison of the ABC optimal cost for two locations.**Table 6** The controlling parameters of ABC algorithm for two locations.

	@ Helwan city	@ Zagazig city
The number of colony size	20	26
The number of food sources	10	13
The number of trial	100	100
The number of cycles	1000	1500

first type of the battery charger of power rating of 300 W. The optimal cost is 54,317 \$ which lead to 9.7692 \$/wh. The proposed method is more optimal than one described by Koutroulis et al. [3] as the obtained minimum cost is due to the proposed technique. Additionally, the analysis described by Koutroulis et al. [3] is built on limited database of PV modules, Batteries, and chargers; so the analysis is based on five types of modules, batteries, and chargers. All the permutations and combinations, 125 cases, are analyzed using both ABC and GA algorithms for each available device. The minimum cost for each PV module using GA is obtained and compared to ABC as given in Table 4. For large available database of the PV system components, the possibility of obtaining a correct optimal solution is valid. Referring to Table 4; it is clear that due to the GA results, the optimal solution is case (5) which comprises 11 PV modules of CS5C-90, 12 batteries of 230 Ah and one charger of 1152 W; the final optimal cost is 7.0237 \$/wh which means 1952.6 \$ per year. According to ABC algorithm, the optimal solution is the same case of GA, but the optimal cost is 7.0189 \$/wh which means 1951.3 \$/year. In order to ensure that the load is covered

during our analysis, Fig. 9 shows the battery power and the PV array power distribution to cover load during some selected cases. The load is fully covered by the proposed technique during the day. Fig. 10 shows a comparison between the GA and ABC optimal cost at Helwan city. Due to the nature of the bee colony, it can be found in many areas and many locations, so it is important to select another location to perform the proposed methodology. The selected location is Zagazig city located at latitude 30.57N, 31.5E. A comparison of the maximum power extracted from each PV module for two locations is shown in Fig. 11. After the maximum power from each module is obtained, the ABC algorithm is applied to optimal size of the PV system for Zagazig city as shown in Table 5. From Table 5, one can derive that the optimal cost is 7.7104 \$/wh in case (28) which means 2143.5 \$/year. A comparison between the ABC optimal cost at Helwan city and at Zagazig city is given in Fig. 12. Table 6 shows a comparison of the ABC algorithm controlling parameters for two locations. From the analysis, one can derive that the proposed methodology is applicable for any location.

## Conclusions

The major aspects which must be taken in consideration in designing a PV power generation systems are reliability and achieve a minimum cost. The past PV system sizing methods suffer the disadvantages of insufficient database of the PV system components, and they did not take into account some affecting aspects such as tilt angle, number of batteries and chargers. In this paper, a new technique for the optimal sizing of stand-alone PV system has been presented and solved by a

new optimization technique Artificial Bee Colony (ABC) algorithm. The purpose of the proposed methodology is to support the selection the optimal number and type of PV modules, and PV battery chargers, the PV modules tilt angle and the battery type and nominal capacity to supply a residential household. Two objective functions are presented: the first is the PV module power which is to be maximized and the second is the life cycle cost (LCC) which is to be minimized. The analysis is performed based on real solar radiation and ambient temperature measured at Helwan city, Egypt. The result of ABC algorithm is compared to GA optimal solution. The simulation results show that the ABC algorithm is more efficient than GA in obtaining the optimal cost of the PV system to cover a load at any location.

#### Conflict of interest

*The authors have declared no conflict of interest.*

#### References

- [1] Shrestha GB, Goel L. A study on optimal sizing of stand-alone photovoltaic stations. *IEEE Trans Energy Convers* 1998;13(4): 373–8.
- [2] Maghraby HAM, Shwehdi MH, Al-Bassam GK. Probabilistic assessment of photovoltaic (PV) generation systems. *IEEE Trans Power Syst* 2002;17(1):205–8.
- [3] Koutroulis E, Kolokotsa D, Potirakis A, Kalaitzakis K. Methodology for optimal sizing of stand-alone photovoltaic/wind-generator systems using genetic algorithms. *Sol Energy* 2006;80:1072–88.
- [4] Lalwani M, Kothari DP, Singh M. Size optimization of stand-alone photovoltaic system under local weather conditions in India. *Int J Adv Eng Res* 2011;1(4):951–61.
- [5] Abdulateef J, Sopian K, Kader W, Bais B, Sirwan R, Bakhtyar B, et al. Economic analysis of a stand-alone PV system to electrify a residential home in Malaysia. In: *Advances in fluid mechanics and heat & mass transfer conference*; 2012. p. 169–74.
- [6] Javadi MR, Mazlumi K, Jalilvand A. Application of GA, PSO and ABC in optimal design of a stand-alone hybrid system for north-west of Iran. In: *ELECO 2011 7th international conference on electrical and electronics engineering*, Turkey.
- [7] Kirmani S, Jamil M, kumar C, Jamil AM. Techno economic feasibility analysis of a stand-alone PV system to electrify a rural area household in India. *Int J Eng Sci Technol* 2010;2(10): 5231–7.
- [8] Arun P, Banerjee R, Bandyopadhyay S. Optimum sizing of photovoltaic battery systems incorporating uncertainty through design space approach. *Sol Energy* 2009;83:1013–25.
- [9] Fragaki A, Markvart T. Stand-alone PV system design: results using a new sizing approach. *Renew Energy* 2008;33:162–7.
- [10] Posadillo R, Luque LR. Approaches for developing a sizing method for stand-alone PV systems with variable demand. *Renew Energy* 2008;33:1037–48.
- [11] Karaboga D, Akay B. A survey: algorithms simulating bee swarm intelligence. *Artif Intell Rev* 2009;31(1):68–85.
- [12] Kaur A, Goyal S. A survey on the applications of bee colony optimization techniques. *Int J Comput Sci Eng* 2011;3(8): 3037–46.
- [13] Karaboga D, Akay B. A comparative study of artificial bee colony algorithm. *Appl Math Comput* 2009;214:108–32.
- [14] Karaboga D, Ozturk C. A novel clustering approach: Artificial Bee Colony (ABC) algorithm. *Appl Soft Comput* 2011;11(1): 652–7.
- [15] Karaboga D, Ozturk C, Karaboga N, Gorkemli B. Artificial bee colony programming for symbolic regression. *Inf Sci* 2012;209:1–15.
- [16] Karaboga D, Basturk B. A powerful and efficient algorithm for numerical function optimization: artificial bee colony (ABC) algorithm. *J Global Optim* 2007;39(3):459–71.
- [17] Gilbert M. *Renewable and efficient electric power systems*. Hoboken, New Jersey: John Wiley & Sons, Inc.; 2004.
- [18] Othman AM, El-arini MM, Ghitas A, Fathy A. Realworld maximum power point tracking simulation of PV system based on fuzzy logic control. *NRIAG*, 8–11 October 2012, Helwan, Cairo, Egypt.
- [19] Borowy BS, Salameh ZM. Methodology for optimally sizing the combination of a battery bank and PV array in a wind/PV hybrid system. *IEEE Trans Energy Convers* 1996;11(2):367–73.
- [20] Holland JH. *Adaptation in natural and artificial systems*. Ann Arbor: University of Michigan Press; 1975 [Michigan; re-issued by MIT Press 1992].