

Utility of salivary mycophenolic acid concentration monitoring: Modeling and Monte Carlo validation approach

Aleksandra Catić-Dorđević¹  | Nikola Stefanović¹ | Ivan Pavlović² | Dragana Pavlović¹ | Slavoljub Živanović³ | Ana Kundalić¹ | Radmila Veličković-Radovanović^{4,5} | Branka Mitić^{4,5}

¹Faculty of Medicine, Department of Pharmacy, University of Nis, Nis, Serbia

²Faculty of Mechanical Engineering, University of Nis, Nis, Serbia

³Faculty of Medicine, Research Center for Biomedicine, University of Nis, Nis, Serbia

⁴Faculty of Medicine, University of Nis, Nis, Serbia

⁵Clinic of Nephrology, University Clinical Center Nis, Nis, Serbia

Correspondence

Aleksandra Catić-Dorđević, Faculty of Medicine, Department of Pharmacy, University of Nis, Serbia, Blvd Dr. Zorana Đindića 81, 18000 Nis, Serbia.
Email: aleksandra.catic@medfak.ni.ac.rs; aleksandra1610@yahoo.com

Funding information

Ministry of Education, Science and Technological development of Serbia, Grant/Award Number: 451-03-68/2022-14/200113

Abstract

The results of the previous studies demonstrated an association between mycophenolic acid (MPA) exposure, serum albumin level (ALB), and adverse effects in kidney transplant patients. The aim was the identification of mathematical correlation and association between both, total and unbound MPA concentration in relation to ALB, body mass (BM), age and estimated glomerular filtration rate (eGFR) in stable kidney transplant recipients. Furthermore, investigation was conducted with the aim to clarify the role of salivary concentration (C_{SAL}) of MPA in adverse effect profile. In order to analyze the association between total and salivary concentration of MPA in relation to ALB, BM, age and eGFR, a least squares method for determining the correlation between these parameters was performed. In addition, derived mathematical model based on experimental data can also be performed and simulated through the Monte Carlo (MC) approach. Adverse effects were grouped according to the nature of symptoms and scored by a previously published validated system. Numerically calculated values of C_{SAL} from the models [$C_{SAL} = f(ALB, BM, age, eGFR, C_p) = a_{00} + a_{10} * (ALB, BM, age, eGFR) + a_{01} * C_p$] were then compared with those from validation set of patients, where the best fitting model was for ALB [$C_{SAL} = 54.96 - 1.64 * ALB + 13.4 * C_p$]. Adverse effects estimation showed the difference in esthetic score, positively correlated with C_{SAL} in the lower ALB group (145.41 ± 219.02 vs. 354.08 ± 262.19 ; with statistical significance $p = .014$) and almost significant for gastrointestinal score (167.69 ± 174.79 vs. 347.55 ± 320.95 ; $p = .247$). The study showed that C_{SAL} MPA may contribute to management of adverse effects, but these findings require confirmation of clinical utility.

KEYWORDS

adverse effects, albumin level, Monte Carlo simulation, mycophenolic acid, salivary concentration

Abbreviations: ALB, serum albumin levels; AUC, area under the concentration-time curve; CNS, central nervous system; C_p , plasma concentration of mycophenolic acid; C_{SAL} , salivary concentration of mycophenolic acid; EC-MPS, enteric-coated mycophenolate sodium; EST, esthetic; GIT, gastrointestinal; MC, Monte Carlo; MMF, mycophenolate mofetil; MPA, mycophenolic acid; OST, osteomuscular.

This is an open access article under the terms of the [Creative Commons Attribution-NonCommercial](https://creativecommons.org/licenses/by-nc/4.0/) License, which permits use, distribution and reproduction in any medium, provided the original work is properly cited and is not used for commercial purposes.

© 2022 The Authors. *Pharmacology Research & Perspectives* published by British Pharmacological Society and American Society for Pharmacology and Experimental Therapeutics and John Wiley & Sons Ltd.

1 | INTRODUCTION

Mycophenolate mofetil (MMF) and enteric-coated mycophenolate sodium (EC-MPS) are frequently prescribed as a part of immunosuppressive protocols following kidney transplantation in combination with corticosteroids and calcineurin inhibitors.¹ Although there has been a constant effort for more efficient and safe immunosuppressive drugs, results are limited.^{2,3} Usually, mycophenolic acid (MPA) is administered orally, as MMF or EC-MPS in long time period. Nowadays, in routine clinical post-transplantation practice, the common dosage regimen for MMF is 500 or 1000mg twice-daily and for EC-MPS is 360 or 720mg twice-daily. Although neither is considered to be a narrow therapeutic index drug, it should not be practice for careless switching between the different drug products, including innovator drug and generic formulations, or between generic formulations.⁴ After oral administration, MMF and EC-MPS are completely converted into MPA, which is extensively bound to serum albumin (ALB) with only 1%–3% of the unbound MPA, which is pharmacologically active form of MPA.⁵ Mycophenolate seems to be supreme in comparison to other antimetabolite drugs in kidney transplantation due to better graft survival and it has an acceptable risk–benefit when it comes to administration to higher than standard doses. Therefore, it is likely that MPA will continue to be prescribed on a large scale in the upcoming years.⁴ On the other hand, low compliance to MPA is relatively common due to adverse effects, which favors individualized approach compared to fixed dose practice.^{6,7} It was demonstrated that gastrointestinal (GIT) side effects and hematologic toxicity were the main reason for the dose reduction of MMF in the first post-transplant year.⁸ Previous studies noticed change in MPA-albumin binding in patients with unstable kidney function, hypoalbuminemia and uremia, which may expose patients to adverse effects. This decrease in protein binding seems to be caused both by the uremic state itself and by competition with the retained metabolite mycophenolic acid glucuronide (MPAG).^{9,10} Mycophenolic acid pharmacokinetics demonstrated significant intra- and interindividual variability. Interindividual and intraindividual variability in the pharmacokinetics of several drugs has been reported in organ transplant patients. This variability may be due to changes in hepatic function, metabolism and biliary transport of drugs, changes in the plasma protein binding, changes in renal function due to the concurrent use of nephrotoxic drugs such as tacrolimus and cyclosporine. In addition, main reasons for large intraindividual variability are GIT function and food intake. Also, there is potential of low adherence of intraindividual variability.¹¹ It has been shown that plasma MPA exposure, reflected by the area under the concentration-time curve (AUC), varies widely in patients following the same dosage.^{10,12} Previous studies reported that the MPA AUC_{0-12} is closely related to the risk for acute rejection.¹³⁻¹⁵ Also, results of the previous studies demonstrated association between MPA exposure, ALB and adverse effects.^{16,17} Besides ALB, most of the studies investigated gene polymorphisms, body mass (BM), age, period of transplantation and creatinine clearance or estimated glomerular filtration rate (eGFR), influence on MPA pharmacokinetics. Still, those associations should

be further clarified.^{18,19} An AUC_{0-12} between 30 and 60mg/L is recommended for desired clinical outcomes.^{20,21} Following those recommendations pharmacotherapy management gives a proof that the imprecise “one-size-fits-all” approach can be successful replaced by the clinically proven MPA target concentration strategy. Consequently, therapeutic drug monitoring might be useful in reducing interindividual variability in MPA exposure, optimizing immunosuppressive therapy and avoiding graft rejection in routine clinical practice.^{16,22} Besides plasma, as the most used fluid for drug monitoring, saliva is assumed to be more suitable for the pharmacometric approach, regarding its non invasive, cost-effective and friendly-time consuming sampling and not requiring trained personnel, particularly for unbound drugs monitoring.^{23,24} Therefore, question that has risen is how to mark a moment or patient when saliva becomes an optimal biological material. Still, this question is related with an effort for clarification of factors that might influence MPA plasma-saliva relationship.

The approaches based on mathematical modeling could be of a great assistance to make right decision regarding potential utility of salivary MPA concentration (C_{SAL}) in kidney transplantation. In addition, derived mathematical model based on experimental data, can be further validated and simulated through Monte Carlo (MC) approach, which can increase the credibility of the given model. Mathematical approach can help in establishing the link between total plasma (C_P), C_{SAL} of MPA and various factors that influence C_P - C_{SAL} relationship, such as ALB. Considering this, MC simulation could be a most useful approach in identification of ALB concentrations significance for inter-individual MPA pharmacokinetic variability.²⁵⁻²⁷

The aim was the identification of mathematical correlation and association between both, total and unbound MPA concentration in relation to ALB, BM, age and eGFR in stable kidney transplant recipients. Furthermore, investigation was conducted with the aim to clarify the role of C_{SAL} MPA in adverse effects profile.

2 | PATIENTS AND METHODS

The cross-sectional study was conducted within adult kidney transplant recipients who had been treated in the Clinic of Nephrology, University Clinical Centre of Nis, Nis, Serbia, in period of 6 months from the beginning of October 2018. Inclusion criteria were post-transplant period at least 12 months, stable graft function and MPA as part of immunosuppressive protocol based mostly on tacrolimus and low prednisone levels. In addition, the study included patients without clinical significant hypoalbuminemia (serum albumin levels above 25 g/L).⁹ Two oral pharmaceutical formulation of MPA were used, MMF (Cellcept®, Roche, 500–1000mg twice daily) or EC-MPS (Myfortic®, Novartis Pharma, 360–720mg twice daily). In order to compare different MPA forms, MMF dose were multiplied with a conversion factor of 0.72. Exclusion criteria were unstable graft function and graft rejection in previous 3 months. Informed consent was obtained from all 77 patients. A study protocol has been carried

out in accordance with the Declaration of Helsinki and was approved by the Ethics Committee of the Faculty of Medicine, University of Nis (No: 12-10580-2/6).

2.1 | Sample collection

The both kind of samples - blood and saliva were collected at the same time, aimed to measured trough concentration, C_0 (before morning dose). The volume of blood and saliva taken from each patient were 3 ml and 2 ml, respectively. In order to properly collect saliva, patients were advised to stop eat and drink and to brush their teeth 15 min before sampling. Following, whole blood and saliva were centrifuged 15 min at 1522g at 22°C and stored at -80°C until analytics. Blank was collected from the healthy volunteers under the same conditions.

The cross-sectional study of adverse affects within 2 months period was performed by scoring system that was developed by Meaney et al. from the University of Buffalo.²⁸ In order to use their scoring system, the permission was obtained by one of the investigators.²⁹ Adverse effects were grouped according to nature of symptoms: GIT, esthetic (EST), central nervous system (CNS) and osteomuscular (OST). In addition, total score was obtained.

2.2 | Sample preparation and analysis

For MPA plasma concentration determination, previously validated high performance liquid chromatography (HPLC) method was used.³⁰ Analytical method for C_{SAL} was developed and validated at Laboratory for chromatography at the Faculty of Medicine, University of Nis. Mycophenolic acid standard was $\geq 98\%$ (Sigma) and lot number: O23M4006V. Saliva sample (150 μ l) was transferred into microtubes with 300 μ l of 0.3% methanol solution of trifluoroacetic acid (Merck). Solution was centrifuged for at 15300g for 10 min at 4°C. The obtained supernatant (5 μ l) was analyzed by HPLC. The calibration curve were prepared from working solution of 5 μ g/ml and blank in following concentrations: 5 ng/ml, 25 ng/ml, 50 ng/ml, 100 ng/ml and 500 ng/ml. Detection of MPA was performed using a liquid chromatography-mass spectrometry (LC-MS) system consisting of Dionex Ultimate 3000 UHPLC and TSQ Quantum Access MAX (Thermo Scientific). The software Thermo Xcalibur 3.0.63 (Thermo Scientific) was used. The separation was performed using Hypersil GOLD column (100 \times 2.1 mm, 1.9 μ m particle size) (Thermo Scientific) maintained at 30°C. The mobile phase consisted of solvent A (0.1% formic acid in water) and solvent B (methanol) (Carlo Erba). Isocratic elution was performed at a flow rate of 0.2 ml/min with the ratio of mobile phase A:B at 20:80. The mass spectrometer (MS) detector was operated in positive mode (ESI+) using the following instrument parameters: capillary voltage 5 kV, vaporizer temperature 195°C, capillary temperature 353°C, capillary offset 35V. Nitrogen was used as sheath and auxiliary gas and set to 45 and

5 bar. Mycophenolic acid detection was carried out in the selected reaction monitoring (SRM) mode using the mass transition of m/z 321.23 \rightarrow 207.05. The calibration curve ($y = 2682.8 \times -28700$) was constructed. The calibration curve was linear over the entire concentration range, with a correlation coefficient $r^2 = 9984$.

2.3 | Regression analysis

In order to analyze the association between total and salivary concentration of MPA, a least squares method for determining the correlation between this parameters was performed. The least squares method is a statistical procedure to find the best fit for a set of data points by minimizing the sum of the offsets or residuals of points from the plotted curve. It is widely used in goal to show correlation between different system parameters and model fitting.³¹ Based on the fact that saliva represents a deproteinized biological fluid, we included ALB in this analysis, but also eGFR, BM and age (years), which seem to be important for MPA pharmacokinetics. With the aim to test the impact of body parameters on C_{SAL} we will suggest mathematical model in the following form: $y = y(x; a_1, a_1, \dots, a_n)$. The aim of least square method is to minimize the function

$$\chi^2(a_1, a_1, \dots, a_n) = \sum_{i=1}^m (y_i - y(x_i; a_1, a_1, \dots, a_n))^2$$

where are a_1, a_1, \dots, a_n are n free unknown constants. In our case $n = 3$, the input vector x takes body values Cp, ALB, BM, age and eGFR, and the output y presents C_{SAL} . Therefore, in order to fit this model, the $n = 77$ know parameters (C_{SAL} , Cp, BM...) obtained from clinical study was used. For this purpose MATLAB R2017b (MathWorks) software was used.

2.4 | Statistical analysis

Besides system modeling, statistical analysis included descriptive statistics, presented as frequency (%) and absolute number, but as well mean and standard deviation. In addition, in order to compare C_{SAL} between adverse effect score groups, Mann-Whitney U test (not-normally distributed data) was performed. All analyses were performed with SPSS statistical analysis software, version 20.0 (SPSS) at the significance level set at $p < .05$.

3 | RESULTS

Characteristics of the study group were shown in [Table 1](#).

For the purpose of this study and in accordance with experimental measurements from [Table 1](#), a linear regression models which represents C_{SAL} in function of C_p and one of the system parameters ALB, eGFR, BM and age were fitted, where the best result was obtained for the function given in the following form:

$$C_{SAL} = f(\text{ALB, BM, age, eGFR, } C_p) = a_{00} + a_{10} * (\text{ALB, BM, age, eGFR}) + a_{01} * C_p \quad (1)$$

First regression model, which presents dependence of C_{SAL} in function of ALB and C_p , was obtained according to experimental obtained values of ALB, C_p and C_{SAL} , using the fitting process in mentioned software, the following parameters were obtained $a_{00} = 54.96$; $a_{10} = -1.64$; $a_{01} = 13.4$, where the optimization results are presented [Figure 1](#).

The distance between dots and surface presents difference between each experimental C_{SAL} value according to ALB and C_p for each patient and optimized regression surface.

By using the similar procedure, the other models in function of BM, age and eGFR were obtained as:

$$C_{SAL} = f(\text{BM, } C_p) = 50.62 + 0.09 * \text{BM} + 5.18 * C_p, \quad (2)$$

TABLE 1 Characteristics of the study population

Characteristics of the patients	Number (%)
Sex	
Male	53 (68.83%)
Female	24 (31.17%)
Age (years)	44.38 ± 10.37
Time post-transplant (months)	78.25 ± 46.55
Donor type	
Living	59 (76.62%)
Deceased	18 (23.38%)
Number of drugs in therapy	
<5	9 (11.69%)
≥5	68 (88.31%)
MPA dose	
720mg	49 (63.64%)
>720mg	28 (36.36%)
C_{SAL} (ng/ml)	62.93 ± 25.82
C_p (µg/ml)	5.22 ± 2.28
Prednisone dose	
<10 mg	53 (68.83%)
≥10 mg	24 (31.17%)
Calcineurin inhibitors	
TAC	68 (88.31%)
CsA	9 (11.69%)
Hematocrit	
Low level	24 (31.17%)
Normal level	51 (66.23%)
High level	2 (2.60%)
Body mass (kg)	74.77 ± 11.93
Albumin (g/L)	39.98 ± 3.71
Serum creatinine (µmol/L)	129.67 ± 21.52
eGFR (ml/min/1.73m ²)	52.52 ± 10.91

Abbreviations: C_p , plasma MPA concentration; CsA, cyclosporin A; C_{SAL} , salivary MPA concentration; eGFR, estimated glomerular filtration rate; MPA, mycophenolic acid; Tac, tacrolimus.

$$C_{SAL} = f(\text{age, } C_p) = 65.38 - 0.15 * \text{age} + 5.172 * C_p, \quad (3)$$

$$C_{SAL} = f(\text{eGFR, } C_p) = 77.91 - 0.365 * \text{eGFR} + 4.858 * C_p. \quad (4)$$

Validation of the given models.

The characteristics of the external validation set are shown [Table 2](#).

In goal to compare previous models, MC simulation method is performed with new external validation set. The example of validation procedure is presented for model 1. According to its definition (1), the following simple simulation scheme is constructed and presented in [Figure 2](#).

Input values of ALB and C_p in simulation scheme were recalculated 1000 times in range of upper and lower limits of this parameters from validation group: $C_{SAL} = 100.03 \pm 48.1$ ng/ml, $C_p = 8.3 \pm 6.15$ µg/ml and ALB = 39.33 ± 3.1 g/L. For each of input pairs ALB and C_p the parameter C_{SAL} , which presents output in this simulation, is calculated according to scheme from [Figure 2](#). After 1000 simulations with different inputs, the 1000 C_{SAL} values were calculated and compared to C_{SAL} from validation group.

The same validation procedure was performed for models (2), (3) and (4) where the adequate validation group parameters were used (BM = 81.21 ± 12.38 , age = 50.3 ± 6.91 and eGFR = 38.18 ± 19.11).

Numerically calculated values of C_{SAL} from models (1–4) were then compared with those from validation group and presented in [Figure 3A](#), where the best fitting model is separated in [Figure 3B](#).

[Figure 3](#) presents the range of the C_{SAL} control group compared to numerically determined values from models (1) to (4). This comparison presents best validation results for model (1) which comparison with experimental results is clearly presented in [Figure 3B](#).

The results from [Figure 3B](#) fully justify the model (1) for correlation between C_{SAL} , ALB and C_p and further determination and prediction between these parameters according to simulation.

In order to analyze the change in MPA concentration in saliva for different ALB values, such as in hypoalbuminemia and clinical significant hypoalbuminemia, a new simulation was performed ([Figure 3](#)). Considering, the proposed model and the range of the measured C_p , C_{SAL} was increased for 23% and 43%, when ALB was between 26–35 g/L and 20–25 g/L, respectively. The obtained results may suggest that therapeutic monitoring of MPA should be considered in accordance to ALB values.

In study population, there has been already published data regarding adverse effects scored by Spasic et al (according to the scoring system developed by Meaney et al.) ([Table 3](#)).

The result analysis showed high intensity of adverse effects related to esthetic skin changes, central nervous system disorders-tremor, insomnia and behavioral disturbances.

Considering the obtained association between C_{SAL} and serum ALB, further analysis was focused on the effect of the pharmacologically active-unbound MPA concentration towards drug adverse effects with respect to ALB ([Figure 4](#)). Albumin levels were divided in two groups: low ALB: 1st tercile (range: 26.30–38.50 g/L); and high ALB: 2nd and 3rd tercile (38.60–48.80 g/L). In the first step patients

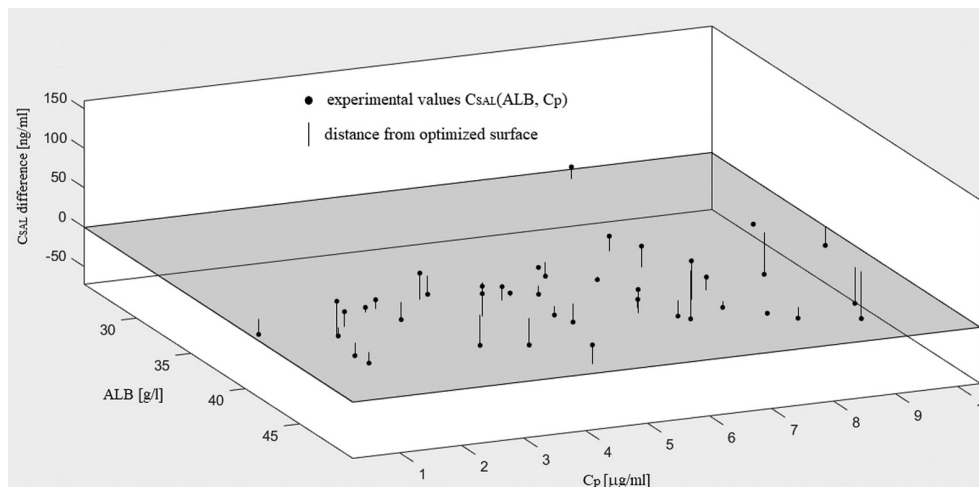

FIGURE 1 Fitting results for model (1). Mathematical approach: fitting process based on a least squares method ($n = 77$). ALB-serum albumin levels; Cp-plasma concentration of MPA; C_{SAL} -salivary concentration of MPA.

TABLE 2 Characteristics of the external validation group

Characteristics of the patients	Number (%)
Sex	
Male	16 (69.56%)
Female	7 (30.44%)
Age (years)	50.3 ± 6.91
Time post-transplant (months)	35.28 ± 20.42
Donor type	
Living	20 (86.96%)
Deceased	3 (13.04%)
CSAL (ng/ml)	100.03 ± 48.1
CP (µg/ml)	8.3 ± 6.15
Albumin (g/L)	39.33 ± 3.1
Body mass (kg)	81.21 ± 12.38
eGFR (ml/min/1.73 m ²)	38.18 ± 19.11

Abbreviations: C_{SAL} , salivary MPA concentration; C_p , plasma MPA concentration; eGFR, estimated glomerular filtration rate.

were scored regarding the experience of GIT, EST, CNS, OST and overall adverse effects in the previous 2 months. In the second step, patients were divided based on the albumin level and the adverse effects obtained score. Considering GIT, EST, CNS, OST score, patients were divided in two groups: low score (without or one sign/symptom noticed) and high score (two or more signs/symptoms noticed). In addition, concentration of MPA in saliva was compared regarding an adverse effects score within different ALB groups. The obtained results showed statistical difference in EST score, whereas higher EST score was associated with higher MPA saliva concentration in lower albumin level group (145.41 ± 219.02 vs. 354.08 ± 262.19 ; $p = .014$) (Figure 5). Also, the same difference was noticed in GIT score, but it did not achieved statistical significance (167.69 ± 174.79 vs. 347.55 ± 320.95 ; $p = .247$). On the other hand, plasma MPA concentration in correlation with scores did not show any significant difference.

4 | DISCUSSION

The clinical practice is constantly looking for progress in therapy management, particular in vulnerable patient group. Therefore, pharmacotherapy specialists have been aimed for better health outcomes and quality of life of kidney transplant patients.³²⁻³⁴ For this reason, they often use mathematical tools and simulations to make a link between drug exposure and their risk/benefit ratio.²¹ Mycophenolic acid has been routinely prescribed as part of immunosuppressive protocol after kidney transplantation. In clinical practice, dosage regimen of MPA is simplified due to lower toxic potential compared to calcineurine inhibitors, cyclosporine A or tacrolimus. Still, some studies have emphasized the individual approach to MPA trough plasma or salivary monitoring, especially in patients with lower ALB.^{15,35,36} Therefore, monitoring of C_{SAL} of MPA could be a good clinical practice in assessment of unbound MPA levels.

Tönshoff et al. suggested clinical utility of MPA monitoring in order to avoid under-immunosuppression, particularly in patients with high immunologic risk in the early post-transplant period. The authors marked patients, particular pediatric and adolescent, treated with protocols characterized by calcineurin minimization, withdrawal or complete avoidance and/or steroid withdrawal or avoidance as well.³⁶ On contrary, our clinical practice does not follow routinely calcineurine inhibitors and/or steroids avoidance or withdrawal.

Literature data has not been in favor for strict drug monitoring recommendations, but on the other hand there has been a proven benefit regarding efficacy and safety of MPA treatment. In the population pharmacokinetic model, De Winter et al. clearly demonstrated the association between MPA dose and both total and unbound exposure. Also, the same study showed that changes in protein binding due to altered kidney function or plasma albumin concentrations influence total MPA exposure, while unbound MPA exposure was less affected.⁵ This result is opposite to our findings, where unbound MPA was influenced by ALB. Therefore, the implementation of mathematical approach considering monitoring of

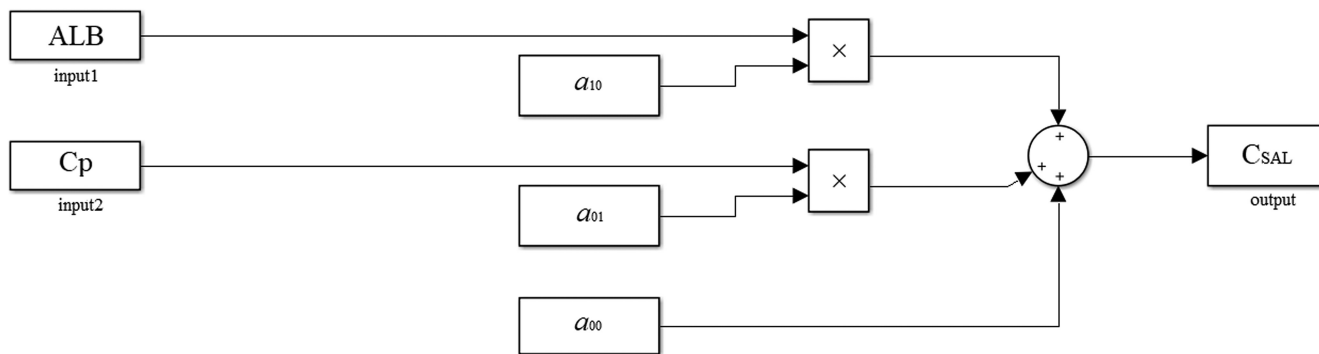

FIGURE 2 Simulation scheme of model 1. ALB-serum albumin levels; C_{SAL} -salivary concentration of MPA; C_p -plasma concentration of MPA; a_{00} , a_{01} , a_{10} - coefficients from the given model.

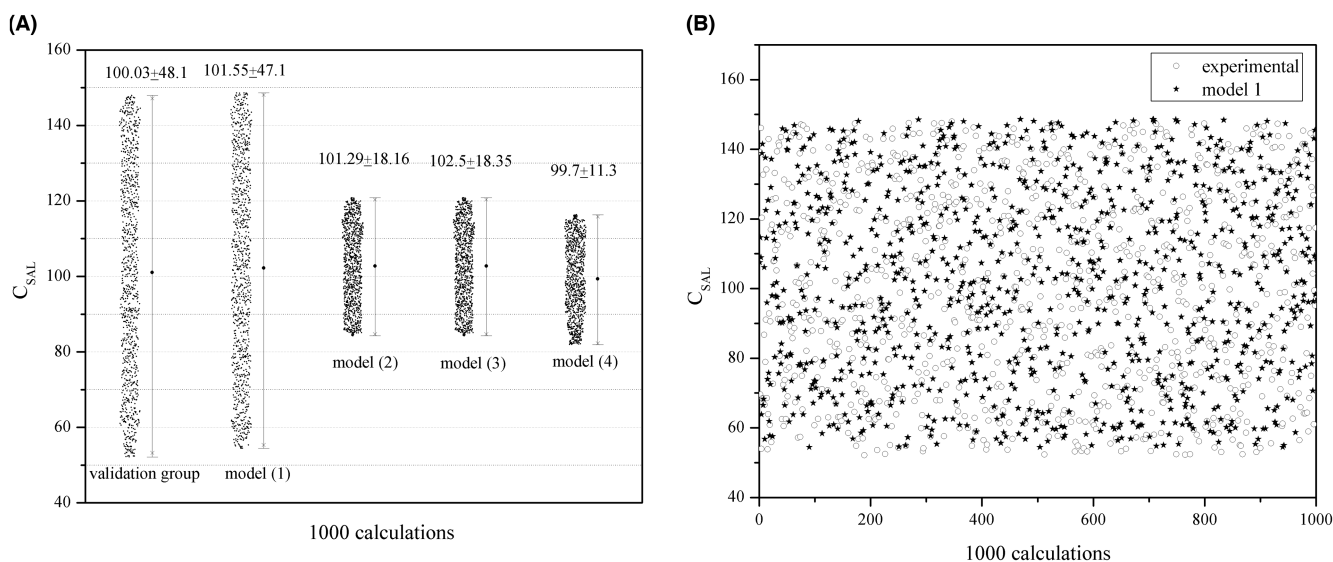

FIGURE 3 (A) Validation of the given models-comparison between simulation data of building models and validation experimental data. Validation by Monte Carlo simulation (1000 simulated patients). C_{SAL} -salivary concentration of MPA; (B) Example of Model 1 validation. Validation by Monte Carlo simulation (1000 simulated patients). C_{SAL} -salivary concentration of MPA.

MPA can be assumed as different view of the association between various ALB and unbound or total concentration of MPA. The established correlation between unbound and total concentration of MPA could be related to efficacy and adverse effects. The equation obtained by fitting the experimental data and post hoc verification by MC simulation, can be useful in assessment of hypoalbuminemia effect on MPA pharmacokinetics based on the changes in unbound MPA, if we simulated plasma concentration within experimental measured range. Our model demonstrated significant increase in unbound MPA for ALB less than 25 g/L which is assumed as clinically significant hypoalbuminemia.⁹ In accordance to that, alternative pharmacokinetic (ie, unbound MPA fraction and metabolites) and pharmacodynamic approaches showed clinical utility for prediction of drug efficacy and toxicity.^{19,37,38} Oppositely, some authors did not demonstrate relationship between C_{SAL} and either total or free C_p MPA concentrations. Therefore, they suggested that saliva is not reliable marker of C_p MPA levels.¹²

Our research aimed to make a connection between presence of adverse effects and unbound MPA concentration. In our clinical

practice, blood for MPA determination was taken immediately before morning dose (C_{trough} determination) as part of routine practice. Besides, literature review showed the inconsistencies between timing of MPA monitoring and the occurrence of adverse effects/toxicity, which have negatively influenced the estimation of their association.^{7,38}

Our previous research showed high intensity of different specifier of adverse effects, but results emphasize the women propensity towards GIT (diarrhea, $p = .038$) and EST (skin changes, $p = .037$) adverse effects. The same study reported that stable kidney transplant recipients experienced GIT symptoms, even when they received a proton pump inhibitor or ranitidine.²⁹ Various GIT adverse effects can be reported after administration of MPA.^{39,40} The authors suggested that the watery afebrile diarrhea is the most common adverse effects with an incidence of 36% in renal transplant recipients.⁴⁰ Our study group with stable kidney transplant patients still reported incidence of diarrhea in 25%. Although, GIT adverse effects have been thoroughly investigated, EST effects profile have not been yet clarified, but they could be considered from aspect of

TABLE 3 Frequency of severity scores for immunosuppressive adverse effects (Spasic et al. 24)

Adverse effects	0	1+	2+	3+	Overall frequency(%)
Vomiting	69	8	0	NA	10.39
Diarrhea	58	18	1	NA	24.68
Dyspepsia	60	12	3	2	22.08
Acid suppressive therapy	15	57	5	NA	80.52
Acne	56	10	9	2	27.27
Skin changes	46	22	8	1	40.26
Hirsutism	70	5	2	0	9.09
Moon facies	43	26	7	1	44.16
Gingival hyperplasia	53	17	7	NA	31.17
Buffalo hump	74	3	NA	NA	3.90
Tremor	41	28	6	2	46.75
Headache	54	23	NA	NA	29.87
Insomnia	44	24	8	1	42.86
Myopathy	44	22	11	0	42.86
Ophthalmic changes	72	5	NA	NA	6.49
Mania/Excitable behavior	40	31	6	NA	48.05
Depression	49	26	2	0	36.36
PTDM	65	12	NA	NA	15.58

Abbreviations: NA, not applicable; PTDM, Post-transplant diabetes mellitus.

FIGURE 4 Concentration of MPA in saliva in accordance to ALB values: MC simulation. Descriptive statistics ($n = 77$). ALB-serum albumin levels; C_p -plasma concentration of MPA; C_{SAL} -salivary concentration of MPA.

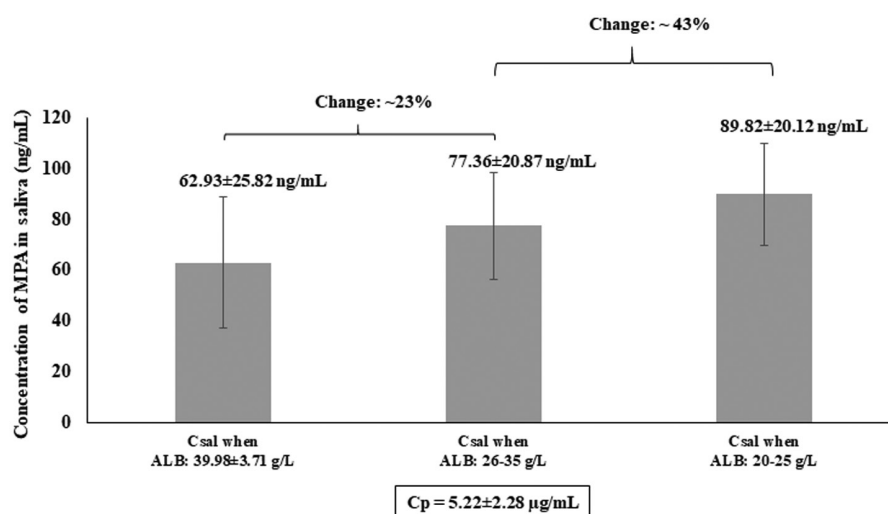

patients' adherence. Nevertheless, it is already known that steroids can cause EST adverse effect.⁴¹ Still considering this study group and very low steroid dose in long-term post-transplantation period (5–10 mg/day), their contribution is minimal. Furthermore, we have established the association between unbound MPA concentration and EST score in patients with different ALB. In accordance to results of the present study, low ALB group demonstrated an association between higher EST score and higher C_{SAL} , which means that increasing of C_{SAL} may lead to increased intensity of adverse effects. In addition, this finding indicated a need for more precise monitoring of MPA in clinical practice due to increased risk of adverse effects in patients with hypoalbuminemia. Also, limitations of the study should

be mentioned. One of the limitations was small number of participants and fact that all were in long-term post-transplantation period. In accordance with clinical circumstances only measurement of total plasma or salivary MPA was obtained, but not unbound plasma MPA concentration or metabolite MPAG. In addition, potential significant gene polymorphism was not considered in the phase of model building, which remain future perspective. A main advantage of this study was demonstrated association between salivary concentration and adverse effects. Future investigation will include confirmation and validation of the given models in large population group of patients, including wider indication area, such as liver transplantation and autoimmune diseases.

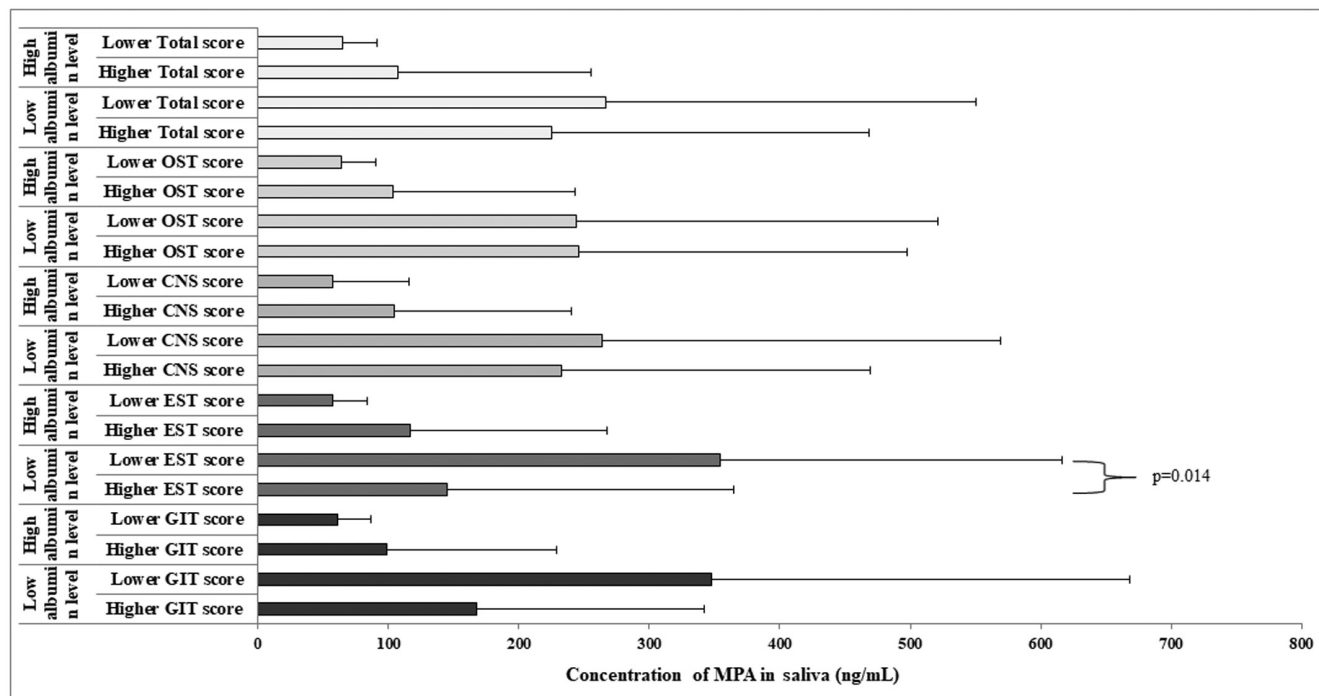

FIGURE 5 Association between salivary MPA and adverse effects score between two albumin level groups. Mann-Whitney U test ($n = 77$). CNS, central nervous system; EST, esthetic; GIT, gastrointestinal; OST, osteomuscular.

5 | CONCLUSION

Mycophenolic acid is usually administered at a fixed dose, but the increasing knowledge of many factors contributing to its interindividual and intraindividual pharmacokinetic variability may rationalize the need for clinical monitoring of MPA in kidney transplant patients. Therefore, the present study investigated association between both, total and unbound MPA concentration in relation to ALB, BM, age and eGFR. Still, the findings of the study demonstrated clinically relevant only association only between total C_p , C_{SAL} of MPA and serum ALB using proposed mathematical approach, which is consisted of a least squares fitting method and MC simulation. An information regarding serum ALB may represent an additional value to clinical practice as significant patient factor, which simultaneously alongside salivary MPA, may optimize its treatment in kidney transplant recipients. Besides, the study showed that C_{SAL} MPA monitoring may contribute to management of adverse effects. Still, monitoring of C_{SAL} MPA needs more evidence of clinical utility.

AUTHOR CONTRIBUTIONS

Participated in research design: ACD; Conducted experiments: IP, SŽ, AK; Performed data analysis: ACD, NS; Wrote or contributed to the writing of the manuscript: ACD, NS, IP, DP, SŽ, AK; Supervision: RVR, BM.

ACKNOWLEDGMENT

The study was supported by the Ministry of Education, Science and Technological development of Serbia (grant: 451-03-68/2022-14/200113).

DATA AVAILABILITY STATEMENT

The data that support the findings of this study are available from the corresponding author upon reasonable request.

DISCLOSURES

The authors declare no conflicts of interest.

ORCID

Aleksandra Catić-Đorđević  <https://orcid.org/0000-0001-5430-1819>

REFERENCES

1. Staatz CE, Tett SE. Pharmacology and toxicology of mycophenolate in organ transplant recipients: an update. *Arch Toxicol*. 2014;88:1351-1389.
2. Mourad G, Glyda M, Albano L, et al. Incidence of posttransplantation diabetes mellitus in de novo kidney transplant recipients receiving prolonged-release tacrolimus-based immunosuppression with 2 different corticosteroid minimization strategies: ADVANCE, a randomized controlled trial. *Transplantation*. 2017;101:1924-1934.
3. Axelrod DA, Naik AS, Schnitzler MA, et al. National variation in use of immunosuppression for kidney transplantation: a call for evidence-based regimen selection. *Am J Transplant*. 2016;16:2453-2462.
4. van Gelder T, Hesselink DA. Mycophenolate revisited. *Transpl Int*. 2015;28:508-515.
5. de Winter BC, van Gelder T, Sombogaard F, Shaw LM, van Hest RM, Mathot RA. Pharmacokinetic role of protein binding of mycophenolic acid and its glucuronide metabolite in renal transplant recipients. *J Pharmacokinetic Pharmacodyn*. 2009;36:541-564.
6. Jiao Z, Zhong JY, Zhang M, Shi XJ, Yu YQ, Lu WY. Total and free mycophenolic acid and its 7-O-glucuronide metabolite in Chinese adult renal transplant patients: pharmacokinetics and application of limited sampling strategies. *Eur J Clin Pharmacol*. 2007;63:27-37.

7. Tett SE, Saint-Marcoux F, Staatz CE, et al. Mycophenolate, clinical pharmacokinetics, formulations, and methods for assessing drug exposure. *Transplant Rev (Orlando)*. 2011;25:47-57.
8. Vanhove T, Kuypers D, Claes KJ, et al. Reasons for dose reduction of mycophenolate mofetil during the first year after renal transplantation and its impact on graft outcome. *Transpl Int*. 2013;26:813-821.
9. Gatta A, Verardo A, Bolognesi M. Hypoalbuminemia. *Intern Emerg Med*. 2012;7:193-199.
10. Ye Q, Wang G, Lu J, et al. Exposure levels of mycophenolic acid are associated with comorbidities in children with systemic lupus erythematosus. *Lupus*. 2021;30:1808-1818.
11. Pisupati J, Jain A, Burckart G, et al. Intraindividual and interindividual variations in the pharmacokinetics of mycophenolic acid in liver transplant patients. *J Clin Pharmacol*. 2005;45:34-41.
12. Cossart AR, Staatz CE, Gorham G, Barraclough KA. Comparison of free plasma versus saliva mycophenolic acid exposure following mycophenolate mofetil administration in adult kidney transplant recipients. *Clin Biochem*. 2022;100:78-81.
13. Tornatore KM, Meaney CJ, Wilding GE, et al. Influence of sex and race on mycophenolic acid pharmacokinetics in stable African American and Caucasian renal transplant recipients. *Clin Pharmacokinet*. 2015;54:423-434.
14. Sheng C, Zhao Q, Niu W, Qiu X, Zhang M, Jiao Z. Effect of protein binding on exposure of unbound and total mycophenolic acid: a population pharmacokinetic analysis in Chinese adult kidney transplant recipients. *Front Pharmacol*. 2020;11:340.
15. Kiang TKL, Ensom MHH. Exposure-toxicity relationships of mycophenolic acid in adult kidney transplant patients. *Clin Pharmacokinet*. 2019;58:1533-1552.
16. van Gelder T, Tedesco Silva H, de Fijter JW, et al. Renal transplant patients at high risk of acute rejection benefit from adequate exposure to mycophenolic acid. *Transplantation*. 2010;89:595-599.
17. Metz DK, Holford N, Kausman JY, et al. Optimizing mycophenolic acid exposure in kidney transplant recipients: time for target concentration intervention. *Transplantation*. 2019;103:2012-2030.
18. Reséndiz-Galván JE, Romano-Aguilar M, Medellín-Garibay SE, et al. Population pharmacokinetics of mycophenolic acid in adult kidney transplant patients under prednisone and tacrolimus regimen. *Eur J Pharm Sci*. 2020;150:105370.
19. Zhang HX, Sheng CC, Liu LS, et al. Systematic external evaluation of published population pharmacokinetic models of mycophenolate mofetil in adult kidney transplant recipients co-administered with tacrolimus. *Br J Clin Pharmacol*. 2019;85:746-761.
20. Chen H, Chen B. Clinical mycophenolic acid monitoring in liver transplant recipients. *World J Gastroenterol*. 2014;20:10715-10728.
21. Bergan S, Brunet M, Hesselink DA, et al. Personalized therapy for mycophenolate: consensus report by the international association of therapeutic drug monitoring and clinical toxicology. *Ther Drug Monit*. 2021;43:150-200.
22. Baker RJ, Mark PB, Patel RK, Stevens KK, Palmer N. Renal association clinical practice guideline in post-operative care in the kidney transplant recipient. *BMC Nephrol*. 2017;18:174.
23. Alsmadi MM, Alfarah MQ, Albdarat J, et al. The development of a population physiologically based pharmacokinetic model for mycophenolic mofetil and mycophenolic acid in humans using data from plasma, saliva, and kidney tissue. *Biopharm Drug Dispos*. 2019;40:325-340.
24. Ferreira PCL, Thiesen FV, de Araujo TT, et al. Comparison of plasma and oral fluid concentrations of mycophenolic acid and its glucuronide metabolite by LC-MS in kidney transplant patients. *Eur J Clin Pharmacol*. 2019;75:553-559.
25. van Gelder T, Vinks AA. Machine learning as a novel method to support therapeutic drug management and precision dosing. *Clin Pharmacol Ther*. 2021;110:273-276.
26. Catić-Dorđević A, Pavlović I, Spasić A, et al. Assessment of pharmacokinetic mycophenolic acid clearance models using Monte Carlo numerical analysis. *Xenobiotica*. 2021;51:387-393.
27. Rubio-Langre S, Aguilar-Sola S, Lorenzutti AM, San Andrés MI, de Lucas JJ, Litterio NJ. Pharmacokinetic evaluation of marbofloxacin after intravenous administration at different ages in llama crias, and pharmacokinetic/pharmacodynamic analysis by Monte Carlo simulation. *J Vet Pharmacol Ther*. 2018;41:861-870.
28. Meaney CJ, Arabi Z, Venuto RC, Consiglio JD, Wilding GE, Tornatore KM. Validity and reliability of a novel immunosuppressive adverse effects scoring system in renal transplant recipients. *BMC Nephrol*. 2014;15:88.
29. Spasić A, Catić-Dorđević A, Veličković-Radovanović R, Stefanović N, Džodić P, Cvetković T. Adverse effects of mycophenolic acid in renal transplant recipients: gender differences. *Int J Clin Pharmacol*. 2019;41:776-784.
30. Džodić P, Veličković-Radovanović R, Šmelcerović A, et al. Validation of HPLC method for the determination of mycophenolic acid in human plasma obtained from renal transplant recipients. *Acta Med Medianae*. 2016;55(4):28-36.
31. Féménias JL. Fitting models to correlated data III: a comparison between residual analysis and other methods. *J Mol Spectrosc*. 2005;232:80-101.
32. van Hest RM, Mathot RA, Pescovitz MD, Gordon R, Mamelok RD, van Gelder T. Explaining variability in mycophenolic acid exposure to optimize mycophenolate mofetil dosing: a population pharmacokinetic meta-analysis of mycophenolic acid in renal transplant recipients. *J Am Soc Nephrol*. 2006;17:871-880.
33. Kuypers DRJ, Le Meur Y, Cantarovich M, et al. Consensus report on therapeutic drug monitoring of mycophenolic acid in solid organ transplantation. *Clin J Am Soc Nephrol*. 2010;5:341-358.
34. Oremus M, Zeidler J, Ensom MH, et al. Utility of monitoring mycophenolic acid in solid organ transplant patients. *Evid Rep Technol Assess (Full Rep)*. 2008;164:1-131.
35. Colom H, Andreu F, van Gelder T, et al. Prediction of free from total mycophenolic acid concentrations in stable renal transplant patients: a population-based approach. *Clin Pharmacokinet*. 2018;57:877-893.
36. Tönshoff B, David-Neto E, Ettenger R, et al. Pediatric aspects of therapeutic drug monitoring of mycophenolic acid in renal transplantation. *Transplant Rev (Orlando)*. 2011;25:78-89.
37. de Jonge H, Naesens M, Kuypers DRJ. New insights into the pharmacokinetics and pharmacodynamics of the calcineurin inhibitors and mycophenolic acid: possible consequences for therapeutic drug monitoring in solid organ transplantation. *Ther Drug Monit*. 2009;31:416-435.
38. Monchaud C, Marquet P. Pharmacokinetic optimization of immunosuppressive therapy in thoracic transplantation: part I. *Clin Pharmacokinet*. 2009;48:419-462.
39. Venuto RC, Meaney CJ, Chang S, et al. Association of extrarenal adverse effects of posttransplant immunosuppression with sex and ABCB1 haplotypes. *Medicine (Baltimore)*. 2015;94:e1315.
40. Gioco R, Corona D, Ekser B, et al. Gastrointestinal complications after kidney transplantation. *World J Gastroenterol*. 2020;26:5797-5811.
41. Strathie Page SJ, Tait CP. Mycophenolic acid in dermatology a century after its discovery. *Australas J Dermatol*. 2015;56:77-83.

How to cite this article: Catić-Dorđević A, Stefanović N, Pavlović I, et al. Utility of salivary mycophenolic acid concentration monitoring: Modeling and Monte Carlo validation approach. *Pharmacol Res Perspect*. 2022;10:e01034. doi:[10.1002/prp2.1034](https://doi.org/10.1002/prp2.1034)